



(12) EUROPEAN PATENT APPLICATION

(43) Date of publication:
30.09.1998 Bulletin 1998/40

(51) Int. Cl.⁶: B05B 11/00

(21) Application number: 97830153.9

(22) Date of filing: 28.03.1997

(84) Designated Contracting States:
AT BE CH DE DK ES FI FR GB GR IE IT LI LU MC
NL PT SE
Designated Extension States:
AL LT LV RO SI

(72) Inventor: **Battegazzore, Piero**
15100 Alessandria (IT)

(74) Representative:
Perani, Aurelio et al
c/o JACOBACCI & PERANI S.p.A
Via Visconti di Modrone, 7
20122 Milano (IT)

(71) Applicant:
Guala Dispensing S.R.L.
15047 Alessandria (IT)

(54) **Manually operated pump sprayer with liquid-tight venting means**

(57) Manually-operated pump for spraying liquids comprising a trigger (13), a piston (17), which is actuated by the said trigger in opposition to a reaction spring (35) and can move axially inside a first cylindrical chamber (2) where the compression takes place of the liquid (24) sucked up from a container (23) that can be gripped in one hand, a suction tube (18, 22), one end of which dips into the container (23) and the other end (28) of which is connected to the said first cylindrical chamber (2), a dispensing tube (10) that communicates, on the one hand, with the said first cylindrical chamber (2) and, on the other hand, with an atomizer member (11), first valve means (4, 15, 16, 55) located between the said dispensing tube (10) and the said first chamber (2), second valve means (27) located between the suction tube (18) and the said first cylindrical chamber (2), and a standard element (8, 9) for mounting the pump on to the said container (23) and supporting the said first cylindrical chamber (2) and the said dispensing tube (10). The pump includes a second cylindrical chamber (31), an extension (30) of the said piston (17) that extends axially outside the said first cylindrical chamber (2) and that engages in a sliding manner inside the said second chamber (31). The bottom wall (40) of the said second chamber (31), which faces the said container (23) with the liquid, has a hole (41) through which the said suction tube (18, 21) passes in a sliding manner, the edge of the said hole (41) engaging with the external surface (42) of the said tube (21) and forming a seal with this surface, which seal is liquid-tight but not tight with regard to the air pressurized inside the said second cylindrical chamber (31) by the extension (30) of the said piston.

the upturned position, and for the container for the liquid to be made of plastic with thin walls without the container caving in as a result of an internal drop in pressure.

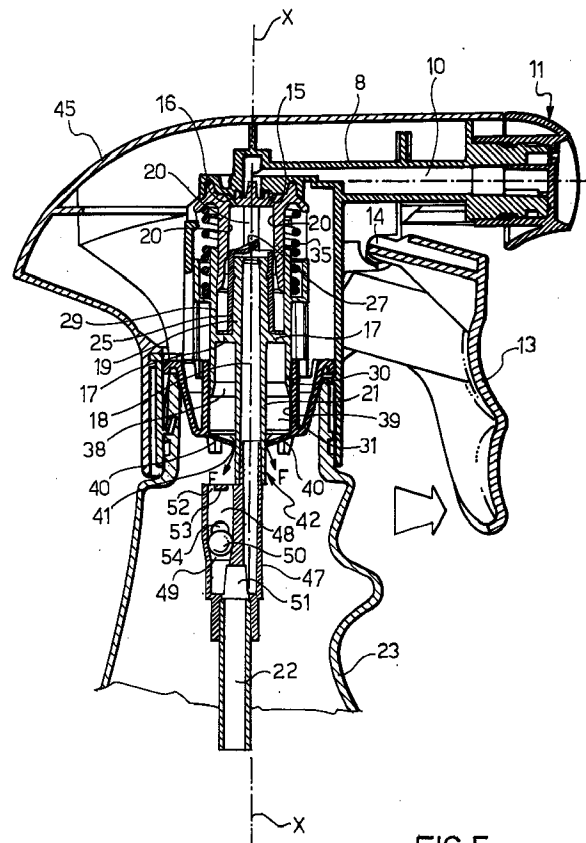

FIG. 5

The above-described structure makes it possible for the container and the spray pump to be used even in

Description

The present invention relates to a manually-operated pump for spraying liquids comprising a trigger, a piston, which is actuated by the said trigger in opposition to a reaction spring and can move axially inside a first cylindrical chamber where the compression takes place of the liquid sucked up from a container that can be gripped in one hand, a suction tube, one end of which dips into the container and the other end of which is connected to the said first cylindrical chamber, a dispensing tube that communicates, on the one hand, with the said first cylindrical chamber and, on the other hand, with an atomizer member, first valve means located between the said dispensing tube and the said first chamber, second valve means located between the suction tube and the said first cylindrical chamber, and a standard element for mounting the pump on to the said container and supporting the said first cylindrical chamber and the said dispensing tube.

Pump sprays of the type mentioned above are extremely well-known within the specific technological sector and are used to spray the most varied types of products, including liquid detergents.

One example is illustrated in patent US-A-4,161,288. During use, the container is usually held in the vertical position with the spraying device on top; clearly, in this position, there is no risk of the liquid leaking out under the effect of gravity and as a result of it seeping through the members that connect the pump to the neck of the container; neither is there any need to provide the connection elements with special sealing devices or fittings.

Nevertheless, the habit of using spray pumps with the container turned upside down in the vertical or virtually vertical position in order to spray liquid on to difficult-to-access areas, has also become commonplace.

In order to allow the spray pump to be used in this way, given that the connection between the spraying apparatus and the container is also upturned, the said connection is fitted with suitable conventional sealing members which prevent the liquid from leaking out, as well as with suitable take-up means in the liquid suction tube which enable the liquid to be taken up not only when the container is in its usual vertical position, with the spraying device on top, but also when it is turned upside down and the liquid collects around the connection between the container and the pump, leaving the opening of the suction tube uncovered, which opening, as is known, is located in the vicinity of the closed base of the container.

One example of a spray pump with a container equipped such that it can also be used in the upturned position is illustrated by way of example in patent US-A-4,277,001.

As the technology relating to pumps for spraying liquids has developed, the need to reduce the weight of the various mechanisms, and first and foremost the

weight of the container, has also become an important factor.

In order to make it as light as possible, the container, which is usually made of moulded plastic, is made with thin walls.

Whereas in the case of spray pumps designed to be used solely in a position above the container with the liquid, the thin walls of the container are not a major disadvantage since there are no sealing members and air can seep freely into the container, in the case of pumps which are also designed for use in the upturned position, as the liquid is dispensed there is a drop in pressure inside the container, with the result that it caves in owing to the thinness of the walls.

This is because the seal present in the connection between the spraying device and the container stops air from the outside, which would otherwise compensate for the pressure drop created inside the container, getting in.

The object of the present invention is therefore to produce a spray pump structure which can be used even upside down, with the container for the liquid being made of plastic with thin walls but without the container caving in as a result of an internal drop in pressure.

The object is achieved with a pump whose characteristics are set forth in the appended claims.

The invention will now be described in greater detail with reference to an example of a preferred embodiment thereof, given by way of illustration in the appended drawings, in which:

Figure 1 shows, in cross-section, the pump according to the invention mounted on a container which contains the liquid to be sprayed and is made of plastic with thin walls, illustrated in the vertical position with the pump on top;

Figure 2 shows, in cross-section, the pump in Figure 1 with the container and the pump in the upturned position;

Figure 3 shows, in cross-section and on an enlarged scale, the pump according to the invention, with the mechanisms in the rest position, prior to starting a spraying operation;

Figure 4 shows, in cross-section, the pump in Figure 3 with the mechanisms shown in an intermediate position, after the spraying operation has started but before the latter has been completed;

Figure 5 shows, in cross-section, the pump in Figure 3 with the pumping mechanisms illustrated in an intermediate position, during the stage in which the liquid is sucked up and air is simultaneously pumped into the container.

With reference to the abovementioned figures, it should be noted that the pump according to the invention comprises a cylindrical body 1 that extends axially in the direction of the vertical axis X-X; this cylindrical body defines a first cylindrical chamber 2 having an

open end 3 and a top closed by the wall 4.

The wall 4 has an annular edge 5 that engages, with the possibility of sliding axially, in an annular groove 6 carried by a body 7 which defines two cylindrical extensions 8 and 9 lying at right angles to each other.

The inside of the extension 8, which is perpendicular to the axis X-X, defines the dispensing tube 10 which terminates in a conventional atomiser member, denoted as a whole by the reference 11.

The extension 9, which extends parallel with the axis X-X and concentrically with the cylindrical body 1, defines the housing 12 for the pump and forms the base for supporting and operating the trigger 13 via which the pump is actuated.

More specifically, the trigger 13 can move angularly around the pivot 14.

The dispensing channel 10 is connected to the said first cylindrical chamber 2 via the passages 15 and 16.

In the rest position, the top wall 4 presses against the opposing surface of the body 7 and the passages 15 and 16 are therefore closed. These, together with the wall 4 and the body 7, constitute the first valve means, located between the chamber 2 and the dispensing tube 10.

A piston 17 with an axial cavity 18 is actuated by the trigger 13 in a to and fro movement along the axis X-X, with its extension 19 projecting inside the cylindrical chamber 2 which has axial ribs 20 arranged in the shape of a cross on its internal surface.

A tubular body 21 extends coaxially from the said piston 17, in the opposite direction to the extension 19, and defines, internally, the continuation of the axial cavity 18 which is connected, in a manner that will be described below, to the suction tube 22 that dips into the container 23 containing the liquid 24 to be sprayed, in particular detergent.

The container 23 is connected to the standard tubular extension 9 via conventional attachment means and suitable sealing members.

Fixed on to the extension 19 of the piston 17 is a sleeve 25, the free end 26 of which is fitted with a flap valve 27 that works in association with the mouth 28 of the said extension 19 in the sense that it keeps the said mouth closed during the stage in which the liquid to be sprayed is compressed, and keeps it open during the stage in which the liquid is sucked up through the tubes 22 and 18.

The said piston 17 is actuated in its reciprocating motion along the axis X-X by the trigger 13, by means of lever-type connection members which are not illustrated since they are not crucial to an understanding of the present invention.

Coaxial to the extension 19 of the piston 17, and integral with the peripheral edge of the said piston, is a tubular sleeve which, via a first part 29, extends until it engages in a sliding manner around the outside of the wall of the cylindrical body 1, and, via a second part 30, which is in the shape of an upturned beaker, extends in

an opposite direction until it engages in a sliding manner inside the chamber 31 defined by a second cylindrical body 32 supported by the tubular extension 9.

Surrounding the part 29 of the said tubular sleeve is an annular collar 33 which defines a cavity 34 that houses one end of the spring 35, the other end of which is engaged in the cavity 36 formed by the flange 37 which is integral with the said first cylindrical body 1.

The edge 38 of the second part 30 of the said sleeve is in the shape of an elastically flexible lip that engages with the internal wall 39 of the second cylindrical chamber 31.

The flexibility of this edge means that the said second part 30 of the sleeve acts like a piston during the movement of the piston 17, with which it is integral as its axial continuation, in accordance with the operating methods which will be described below.

While the second cylindrical body 32 is open at the end facing the first cylindrical body 1, it is closed on the bottom by a flexible wall 40 having a central aperture 41 through which the tubular body 21 passes in a sliding manner, the inside of this tubular body 21 defining the tube 18.

When the pump is in the rest position, and during the spraying stage, the edge of the said aperture 41 forms and defines respectively, with respect to the external surface 42 of the body 21, a seal which is tight enough to prevent the liquid from seeping out along the said surface, even if the container 23 is held upside down and the pump, which is also upside down, is located below it, as illustrated in Figure 2.

However, the flexibility of the wall 40 is such that, when the air inside the second cylindrical chamber 31 is compressed by the piston 30, it allows this pressurized air to pass between the edge of the aperture 41 and the external surface 42 of the tube 21, as indicated by the arrows F in Figure 5 of the drawings.

The standard tubular extension 9 also contains the means, diagrammatically indicated by the reference 43, that enable the spray pump to be fastened to the neck 44 of the container 23.

More specifically, the latter has thin walls and is made using a conventional plastic moulding process.

The spray pump is completed by a conventional cover indicated by the reference 45.

In the region of the joint 46, the suction tube 18 is connected to the body 47 of a device providing additional access so that liquid can be fed to the suction tube 18 even when the container 23 is turned upside down (Figure 2), in which position the tube 22 can no longer suck up liquid.

This body 47 comprises an access channel 48 which extends parallel with the tube 18 and has a conical portion 49 that forms the seating of a ball valve 50. The abovementioned channel 48 is connected to the tube 18 via the passage 51 and has an aperture 52 that faces the bottom wall 40 of the second cylindrical chamber 31. The internal projections 53 prevent the ball 50

from falling out of the tube 48 when the container 23 is turned upside down.

An aperture 54 in the wall of the tube 48 allows the liquid to enter when the latter is sucked up with the container 23 in an upturned position and the ball 50 is resting on the projections 53.

During operation, whether with the container held in its usual vertical position shown in Figure 1, or in the upturned position shown in Figure 2, the liquid to be sprayed is sucked up into the first cylindrical chamber 2 as the extension 19 of the piston 17 moves out of the chamber 2 and as the piston 30 moves into the second cylindrical chamber 31, towards the flexible bottom wall 40.

The air that has entered the chamber 31 by seeping between the wall 39 and the beaker-shaped piston 30 is compressed by the latter and, subsequent to the deformation that takes place in the flexible bottom wall 40, is forced through the annular opening formed between the edge of the aperture 41 and the external surface 42 of the tube 21.

The pressure of the compressed air in the second chamber 31 is in fact sufficient to cause the edge of the aperture 41 around the tube 21 to flex and cause an annular passage to form, this passage not normally being present on account of the fact that the said edge adheres elastically around the external surface of the tube 21.

The pressurized air introduced into the container 23 compensates for the drop in pressure that takes place inside the container following repeated sucking up of the liquid and prevents the said container from caving in, even though it has very thin walls.

The liquid 24, which has been sucked up into the first cylindrical chamber 2, is sprayed as a result of the axial movement of the extension 19 of the piston 17 inside the said cylindrical chamber 2, while the flap valve 27 is held closed by the pressure prevailing inside the chamber.

The liquid 24 which is pressurized in the chamber 2 also enters the passages 15 and 16 formed within the thickness of the top wall 4, and passes out of the said top wall.

As may be seen in Figure 4, the pressurized liquid which has passed behind the wall 4 generates an axial thrust which overcomes that of the spring 35, axially displacing the body 1 in an opposite direction to that of the piston 17.

This displacement causes the zone 55 behind the wall 4 to connect up with the dispensing tube 10 and therefore, via the passages 15 and 16, also causes the said dispensing tube 10 to connect up hydraulically with the cylindrical chamber 2.

Claims

1. Manually-operated pump for spraying liquids comprising a trigger (13), a piston (17), which is actu-

ated by the said trigger in opposition to a reaction spring (35) and can move axially inside a first cylindrical chamber (2) where the compression takes place of the liquid (24) sucked up from a container (23) that can be gripped in one hand, a suction tube (18, 22), one end of which dips into the container (23) and the other end (28) of which is connected to the said first cylindrical chamber (2), a dispensing tube (10) that communicates, on the one hand, with the said first cylindrical chamber (2) and, on the other hand, with an atomizer member (11), first valve means (4, 15, 16, 55) located between the said dispensing tube (10) and the said first cylindrical chamber (2), second valve means (27) located between the suction tube (18) and the said first cylindrical chamber (2), and a standard element (8, 9) for mounting the pump on to the said container (23) and supporting the said first cylindrical chamber (2) and the said dispensing tube (10), characterized in that it comprises a second cylindrical chamber (31), an extension (30) of the said piston (17) extending axially outside the said first cylindrical chamber (2) and engaging in a sliding manner inside the said second chamber (31), the bottom wall (40) of the said second chamber (31) facing the said container (23) with the liquid having a hole (41) through which the said suction tube (18, 21) passes in a sliding manner, the edge of the said hole (41) engaging with the external surface (42) of the said tube (21) and forming a seal with this surface, which seal is liquid-tight but not tight with regard to the air pressurized inside the said second cylindrical chamber (31) by the extension (30) of the said piston.

2. Pump according to Claim 1, characterized in that the said extension (30) of the piston (17) is made of an elastically flexible material and is in the shape of a beaker whose cavity faces the said bottom wall (40) of the said second cylindrical chamber (31).
3. Pump according to Claim 1, characterized in that the said second cylindrical chamber (31) is peripherally connected to the said standard element (9) for mounting on to the neck (44) of the container (23) with the liquid (24).
4. Pump according to Claims 1 to 3, characterized in that the said piston (17) has an axial extension (19) that can slide inside the said first cylindrical chamber (2) and a collar (29) that engages in a sliding manner with the external wall of the said first cylindrical chamber (2).
5. Pump according to Claim 4, characterized in that, on its external wall, the said collar (29) has an annular cavity (34) with a closed base and an open end axially facing the said dispensing tube (10), the

said annular cavity (34) forming a housing and an abutment surface for one end of the said reaction spring (35).

6. Pump according to Claims 4 and 5, characterized in that the said first cylindrical chamber (2) has a top wall (4) facing the said dispensing tube (10), axially sliding engagement means (5) for connection to the said standard element, passages (15, 16) for the liquid which are formed within the thickness of the said top wall (4) and an annular cavity (36) projecting outside the chamber, the said annular cavity (36) forming a housing and an abutment surface for the other end of the said reaction spring (35).
5
10
15
7. Pump according to Claims 1 to 6, characterized in that the said suction tube (18) extends axially inside the said piston (17) and emerges inside the said first cylindrical chamber (2) via an aperture (28) found on the front wall of the extension (19) of the piston.
20
8. Pump according to Claims 1 to 7, characterized in that the said valve means are located in the said aperture (28) of the extension (19) of the piston (17) that emerges inside the said first cylindrical chamber (2).
25
9. Pump according to Claims 1 to 8, characterized in that the said valve means are in the form of a small elastically flexible flap (27) carried on the end of a sleeve (25) fixed on the external surface of the said extension (19) of the said piston (17), the said flap (27) being positioned, by means of the said sleeve, above the said aperture (28) of the suction tube (18).
30
35
10. Pump according to Claims 1 to 9, characterized in that there is additional access (48, 51, 54) to the suction tube (18), this access being fitted with corresponding valve means (50) so that liquid can be fed to the said suction tube (18) even when the container (23) is used in the upturned position.
40
45
50
55

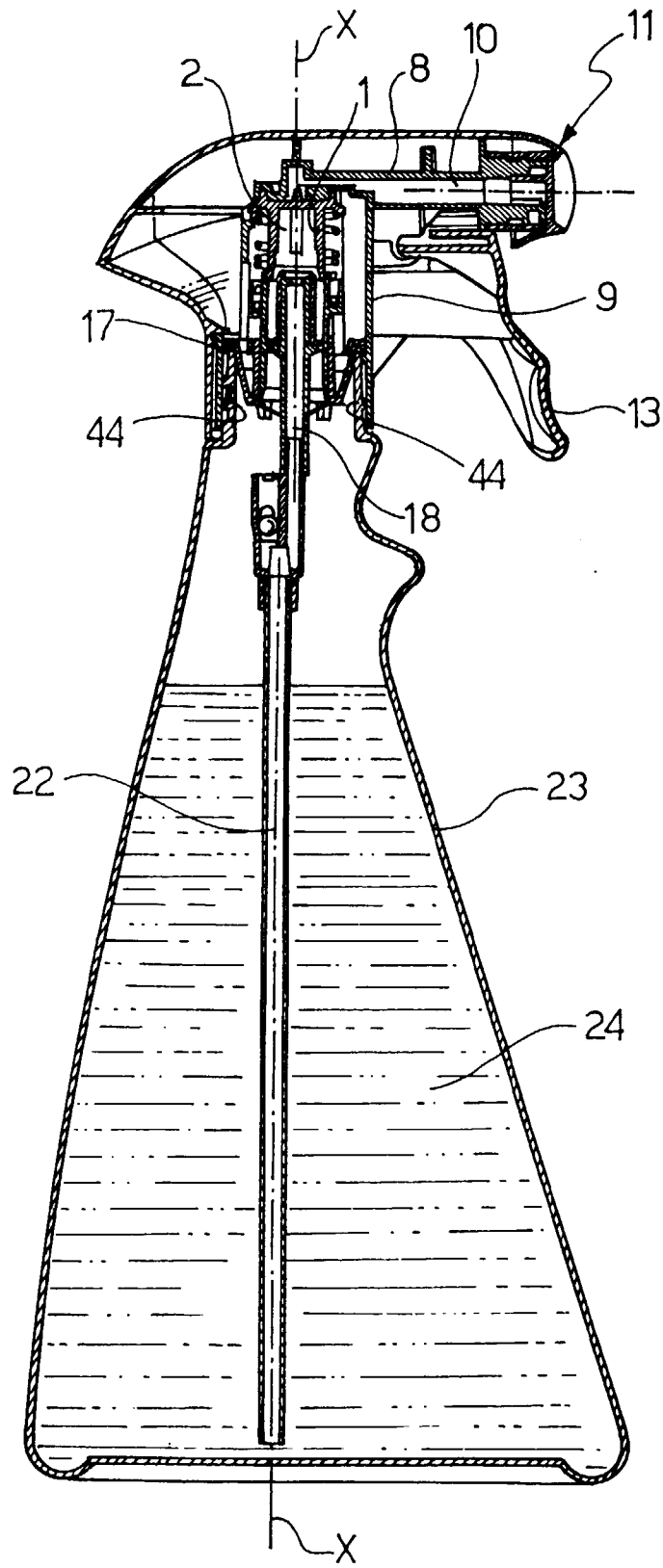

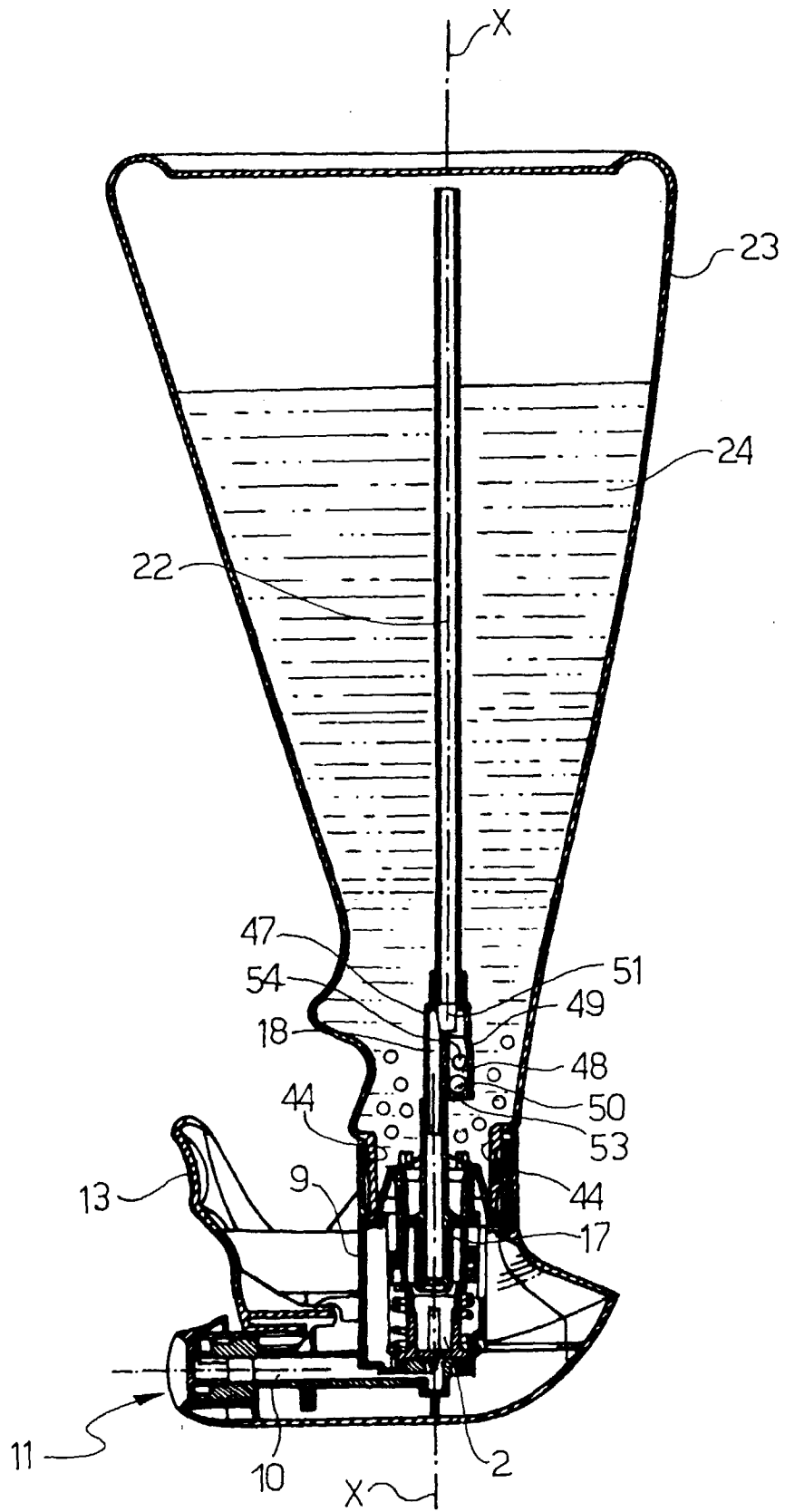

FIG. 2

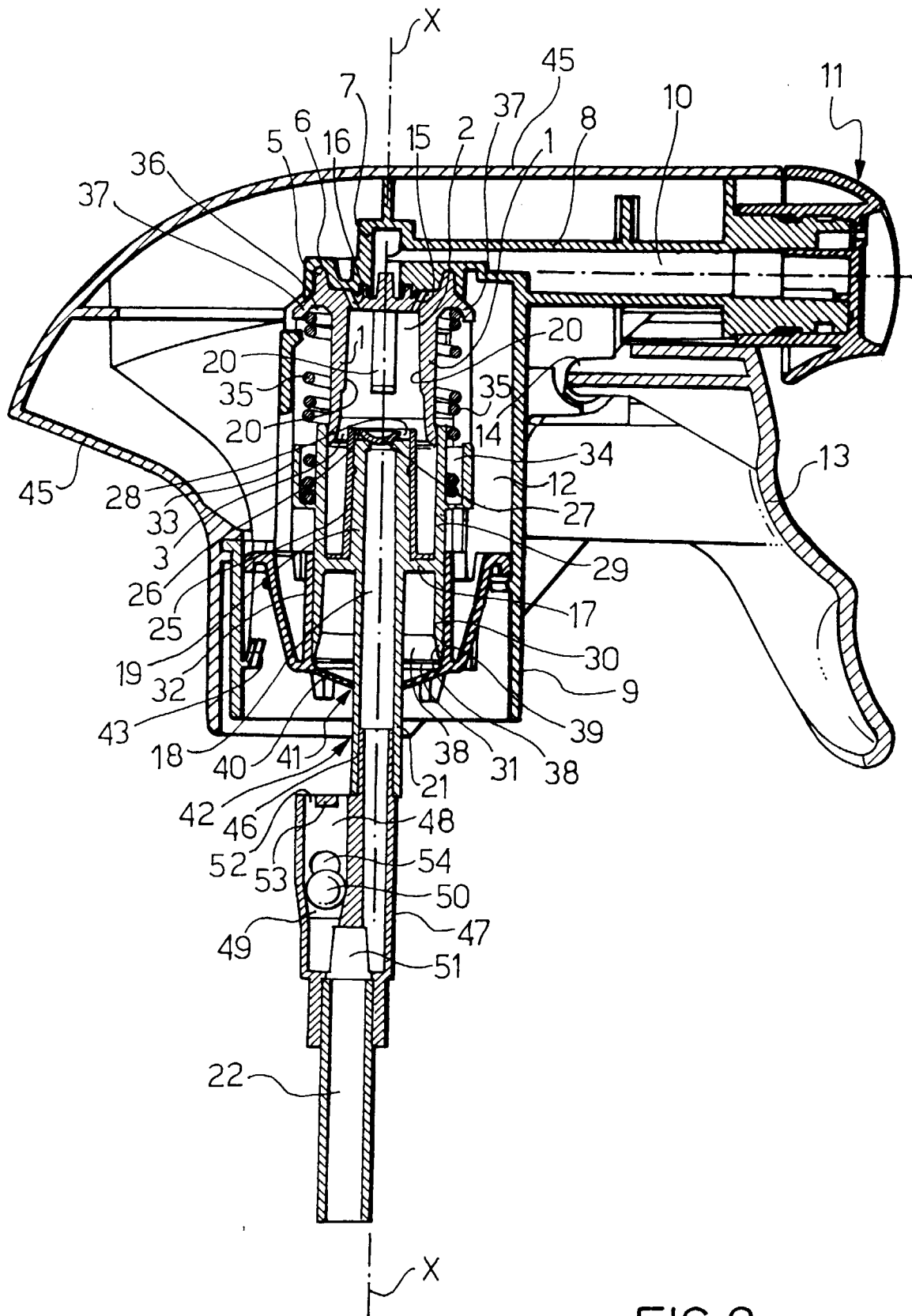

FIG.3

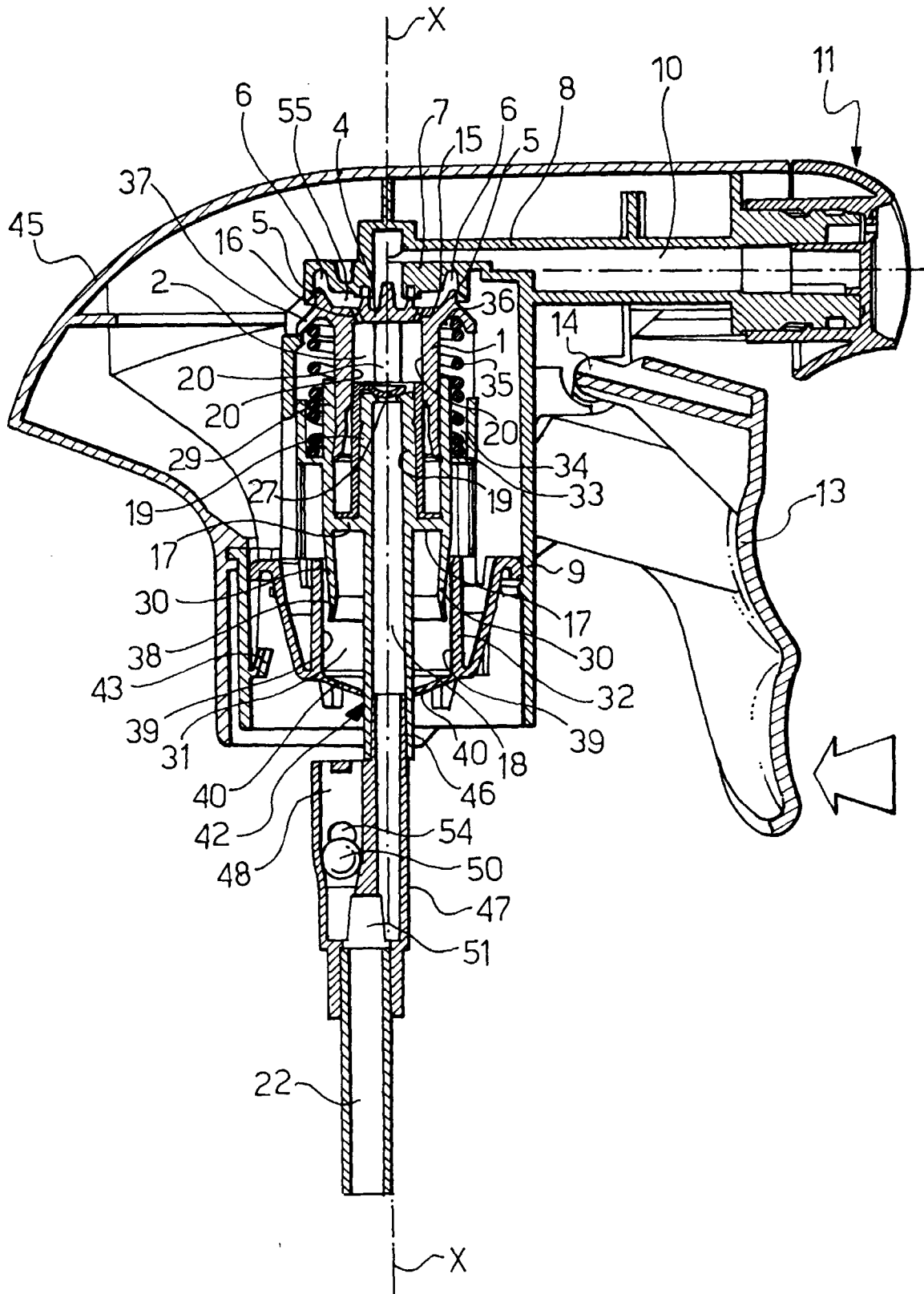
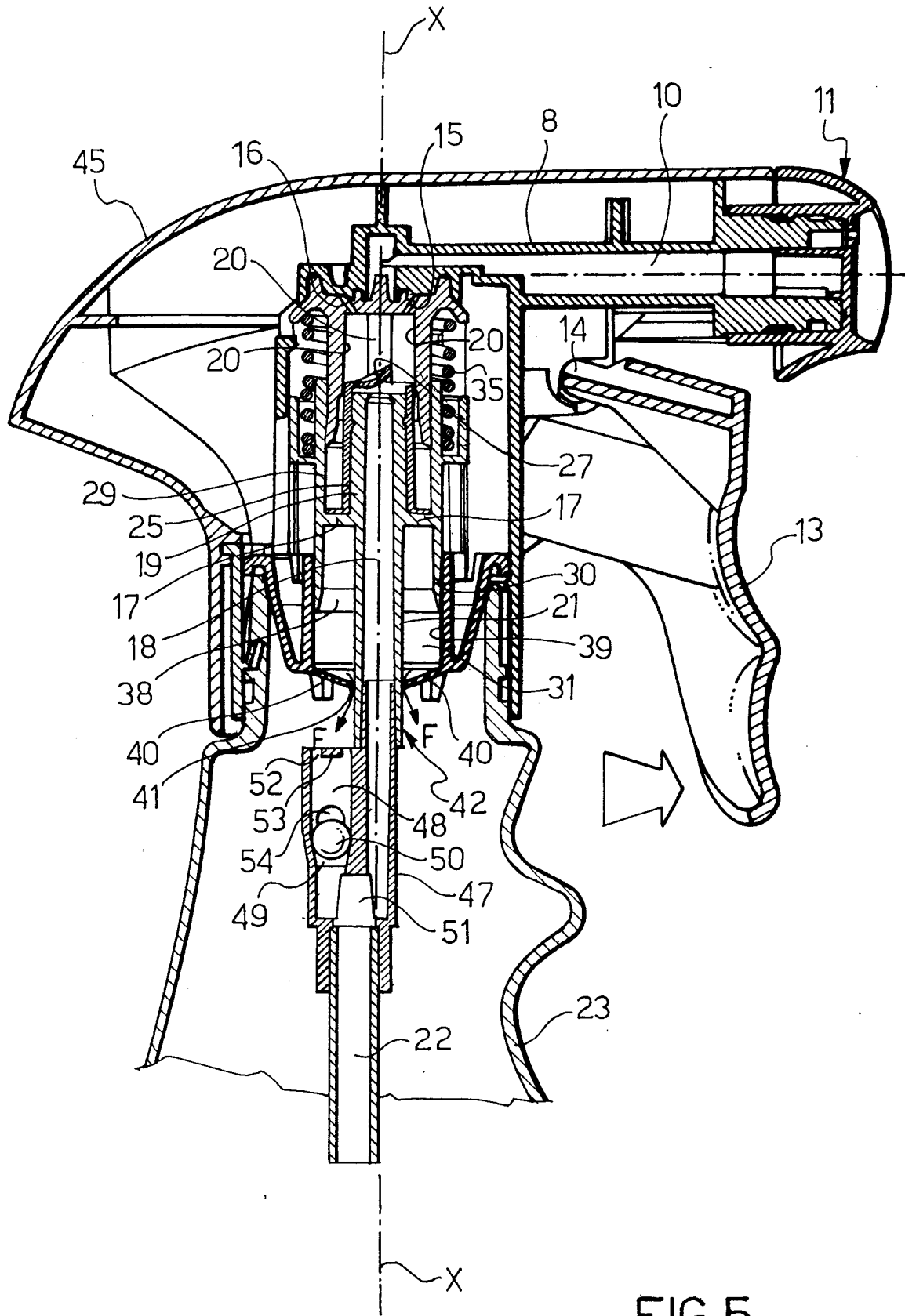

FIG. 4



European Patent
Office

EUROPEAN SEARCH REPORT

Application Number
EP 97 83 0153

DOCUMENTS CONSIDERED TO BE RELEVANT			
Category	Citation of document with indication, where appropriate, of relevant passages	Relevant to claim	CLASSIFICATION OF THE APPLICATION (Int.Cl.6)
A,D	US 4 161 288 A (MC KINNEY) * abstract; figure 1 * ---	1	B05B11/00
A	EP 0 391 292 A (HODEK) * column 4, paragraph 3; figure 1 * ---	1	
A	FR 2 075 992 A (DIAMOND) * page 2, paragraph 1 * * page 5, paragraph 2 * * page 7, line 28 - page 8, line 5; figures 1,3 * ---	1	
A	WO 91 03321 A (MEGAPLAST DOSIERSYSTEME) * page 17, line 2 - line 24; figures 3,5 * ---	1	
A	FR 2 593 243 A (A.I.D.S.A.) * abstract; figures 3,4 * ---	1	
A	GB 2 141 186 A (CORSETTE) * abstract; figure 1 * -----	1	
The present search report has been drawn up for all claims			
			B05B
Place of search		Date of completion of the search	Examiner
THE HAGUE		16 July 1997	Guastavino, L
CATEGORY OF CITED DOCUMENTS X : particularly relevant if taken alone Y : particularly relevant if combined with another document of the same category A : technological background O : non-written disclosure P : intermediate document T : theory or principle underlying the invention E : earlier patent document, but published on, or after the filing date D : document cited in the application L : document cited for other reasons & : member of the same patent family, corresponding document			

EPO FORM 1503 03.82 (P/MCD1)