



(12) **EUROPEAN PATENT APPLICATION**

(43) Date of publication:  
**30.09.1998 Bulletin 1998/40**

(51) Int Cl.6: **B63H 5/14, B63H 23/24**

(21) Application number: **98830151.1**

(22) Date of filing: **18.03.1998**

(84) Designated Contracting States:  
**AT BE CH DE DK ES FI FR GB GR IE IT LI LU MC  
NL PT SE**  
Designated Extension States:  
**AL LT LV MK RO SI**

(72) Inventor: **Lenci, Fabio**  
**00144 Roma (IT)**

(74) Representative: **Taliercio, Antonio et al**  
**ING. BARZANO' & ZANARDO ROMA S.p.A.**  
**Via Piemonte, 26**  
**00187 Roma (IT)**

(30) Priority: **19.03.1997 IT RM970154**

(71) Applicant: **Lenci, Fabio**  
**00144 Roma (IT)**

(54) **Nautical propulsor with ducted rotor propeller**

(57) This invention relates to a nautical propulsor comprising a shell (1) in which one or more propellers (2) are ducted, said shell (1) being rigidly connected to an axle (5), said propellers (2) being rotatively associated to said shell (1) by suitable coupling means and each of said propellers (2) having the rotor member (18)

of a corresponding rotary electric motor associated thereto, the stator member (19) of said electric motor being rigidly connected to said shell (1), so that the rotation of said propellers (2) is rigidly coupled to the rotation of the corresponding rotor member (18), said rotor members (18) and associated stator members (19) being internally housed in the structure of said shell (1).

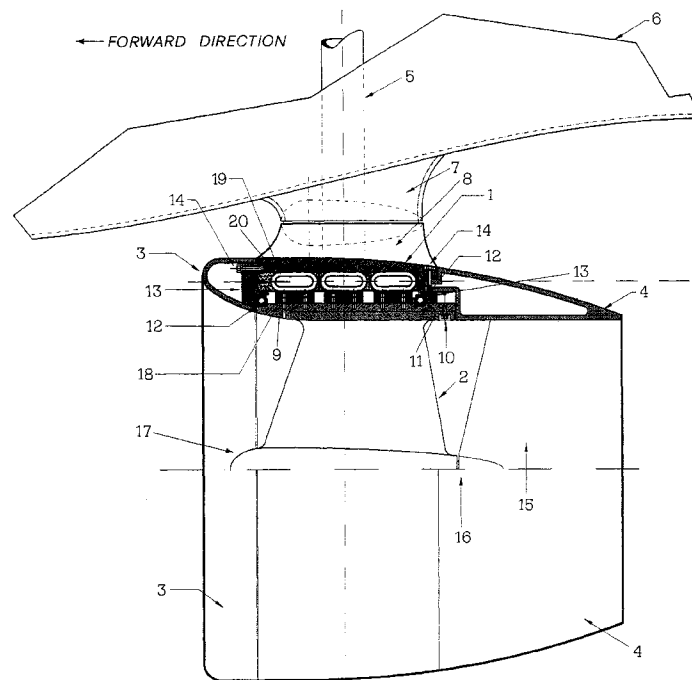

FIG. 1

## Description

This invention relates to a nautical propulsor with ducted rotor propeller.

More particularly, this invention relates to a nautical propulsor of the above outlined type powered by a rotary electric motor and also adapted to perform steering functions.

As it is known, the nautical propulsion based upon use of propellers is the most extensively utilized propulsion system, in view of its construction simplicity as well as of the large number of available and hydrodynamically experimented propulsor types.

The operation means of said propellers may be comprised of motor apparatuses of various kinds, according to the specific propulsion requirements of the boat on which they are installed. In this respect, important parameters of the watercraft in view of choosing a proper propulsion apparatus are the tonnage of the watercraft, the paying load and its possible variability, the speed and the possibility to vary the speed in a more or less extended range, the power consumption and the manoeuvring rapidity

The kinds of generally utilized propulsion plants can be classified as vapor apparatuses, diesel engines, gas turbines and apparatuses with electric transmission. In particular, the electric transmission propulsion apparatuses comprise a prime mover generally consisting of a Diesel engine or a turbine, and an electric motor, driven by said prime mover, that transmits the movement to the propeller shaft. The current technologies allow to indifferently choose a suitable unit among direct current electric motors and alternated current electric motors, even if the direct current motors, however, offer a more extended range of rotation speeds.

Said electric transmission apparatuses offer a number of advantages that, in many applications, make them preferable with respect to other kinds of motor apparatuses.

Said electric propulsors are specifically comprised of an assembly of modular units, separated from one another, characterized by a restricted number of moving mechanical parts which, therefore, appear to be very simple from a manufacturing view point.

Furthermore, use of electric propulsors assures the obtainment of great amounts of electric power for use on board and enables to eliminate all auxiliary power plants, as needed in other motor apparatus types.

Still further, said electric propulsors enable an optimum manoeuvring rapidity to be obtained, since the employment of frequency converters, in the case of alternated current motors, or the employment of switching controllers, in the case of direct current motors, confers to this apparatus a good dynamic response from a fixed point condition (still watercraft) up to the maximum propeller speed, thereby assuring rapid inversion times and maximum torque over the whole range of propeller speeds.

Further advantages of said electric propulsors are represented by a low noise figure, a reduction of the mechanical vibration level and a lower environmental impact due to contaminant emissions, because the prime movers are always operated in such speed and load conditions as to optimize their efficiency.

Still a further advantage is represented by the capability to easily introduce protection means against the possibility that the prime movers be operated in undesired conditions, such as overspeed conditions caused by emersion of the propeller in rough sea situations.

Thanks to the above mentioned modular construction, said electric propulsors are additionally characterized by a noticeable flexibility in respect of the locations where they are housed, in view of the fact that it is possible to distribute the various units to multiple engine rooms, thereby minimizing the overall dimensions.

For the above reasons, the application of electric transmission propulsion apparatuses is being more and more extended to many watercraft types, such as sailboats and motorboats, cruising boats, ferryboats, icebreakers, fishing boats, oceanographic search vessels, cargo vessels, submarines.

Said electric propulsors, however, as well as other kinds of propulsion apparatuses, have some drawbacks related to the presence of a transmission shaft line between the electric motor and the propeller.

In particular, the resulting efficiency of the apparatus is decreased due to the insertion losses connected with said shaft line and, if it is desired to decrease such efficiency loss, it is necessary to adopt constructively complex and expensive approaches, also from a routine maintenance view point.

Besides that, the presence of said transmission shaft or axle line restricts the swinging range of the propeller or even, in respect of watercrafts provided with heavy shaft lines and propellers, it completely eliminates the swinging capability of the propeller. This situation entails that the motor-propeller system does not favourably contribute towards the manoeuvrability of the vessel, which is thereby completely entrusted to the rudder, and, consequently, the overall efficiency of said motor-propeller system is decreasing as the turn angle increases: in fact, the misalignment between the propeller and the rudder reduces the turning power of the latter and therefore it also reduces the thrust generated by the propeller in equal rotation conditions of the motor. This entails a limitation of the turn angles, a very low efficiency of the propulsion apparatus during reverse motion manoeuvres and the need that manoeuvring auxiliary propellers be used in vessels of large dimensions.

In view of all above, the present invention suggests to adopt a solution such as to enable the advantages of electric transmission propulsion apparatuses to be maintained and to contemporaneously solve all above mentioned problems.

It is an object of this invention, therefore, to provide a propeller electric propulsion apparatus, for use both

in surface watercrafts and in submarine watercrafts, having a simple and inexpensive construction, which has no efficiency degradation due to insertion of a transmission shaft line between the motor and the propeller and allows an optimum manoeuvring rapidity to be achieved from a stationary condition, which is a typical starting condition for the watercraft (high standstill thrust and in towing operations) up to the maximum speed of the propeller, thereby assuring fast reversion times and maximum torque through the whole speed range, the apparatus being adapted to enable the so generated thrust to be oriented in a whole 360° range, thereby also enabling the steering functions to be exploited.

Specific subject-matter of this invention, therefore, is a nautical propulsion apparatus consisting of a swinging shell within which one or more propellers are ducted, characterized in that said shell is rigidly connected to a vertical shaft acting as rudderpost and in that said propellers are rotatively coupled to said shell by suitable coupling means and the rotor member of a corresponding electric motor is rigidly connected to each of said propellers, the stator member of said electric motor being rigidly connected to said shell, so that the rotation of said propellers is rigidly coupled to the rotation of the corresponding rotor member, said rotor and stator members being housed within the structure of said shell.

According to this invention, the nautical propulsion apparatus can comprise at least two propellers and the propeller hubs are rotatively or rigidly connected with one another.

Preferably, according to this invention, said shell is a shell known to those skilled in the art as Kort shell having an aerosol cross-section with a decreasing diameter from an input leading edge cone, at the bow end, to an output trailing edge cone, at the stern end.

Further according to this invention, said shell can have a cross-section shape such as to optimize the propulsion efficiency according to the specific requirements of the watercraft.

Preferably, according to the invention, said shaft rigidly connected to said shell is orthogonal with respect to the axis of said shell.

In particular, said shaft rigidly connected to said shell can be rotatively coupled to the boat hull with a swinging range of 0 to 360°.

Further according to this invention, said shaft rigidly connected to said shell can have its portion downwardly depending from the boat hull protected by a first half-fairing integrally connected to said hull and rotatively coupled to said shaft and by a second half-fairing integrally connected to said shell and to said shaft and rotatively coupled to said first half-fairing.

Preferably, according to this invention, said suitable coupling means for connecting said propellers and said shell comprise at least one tubular segment rigidly connected to said propellers, by means of screws which couple the suitably shaped ends of the blades of said propellers to said tubular segment, said tubular seg-

ments matching the profile of said shell so as to form the inner wall of said shell, said tubular segments being rotatively coupled to said shell by means of bearings in order to allow said propellers to rotate with respect to said shell, said bearings being retained in their positions within said shell by means of suitable fastening rings rigidly connected to said shell by means of screws.

Further according to this invention, said shell can be provided with a vertical blade integrally connected to the inner wall of the end portion of said shell.

In particular, said vertical blade, in turn, can be provided with a suitably shaped projection in corresponding position to the axis of said shell, the hub of any adjacent propeller being rotatively coupled to said projection.

Further according to this invention, said nautical propulsion apparatus can be provided with position and speed sensors for said rotor members.

In particular, said sensors can be housed within the structure of said shell and they can be rigidly connected to said shell as well as to a suitable control and power supply electronic circuitry by means of electric cables extending within said shaft rigidly connected to said shell, otherwise said sensors can be rigidly coupled to the hubs of said propellers and they can be connected to a suitable control and power supply electronic circuitry by means of electric cables extending within said shaft rigidly connected to said shell, within said vertical blade and within said projection of said vertical blade.

Further according to this invention, the pole number of said rotor members and the pole number of the related stator members are such as to optimize the speed range and the torque range of said electric motors according to the specific requirements of said watercraft.

Preferably, according to this invention, said stator members are provided with electric windings connected to a suitable control and power supply electronic circuitry by means of electric cables extending within said shaft rigidly connected to said shell.

Further according to this invention, said rotor members can be provided with electric windings coupled to a suitable control and power supply electronic circuitry by means of electric connection elements, consisting of cables and/or wipers, extending within said shaft rigidly coupled to said shell, within said vertical blade, within said projection of said vertical blade and then within the hubs and the blades of said propellers.

Preferably, according to this invention, said electric motors are "brushless" motors, wherein the rotor member includes permanent magnets and the stator member includes electric windings.

In particular, said tubular segments, which form suitable coupling means between said shell and said propellers, can have permanent magnets divided into groups aligned along rows parallel to the axis of said tubular segments integrally connected thereto within the structure of said shell, the apparatus further comprising, within the structure of said shell, electric windings rigidly coupled to said shell and divided into groups aligned

along rows similar to the rows of said permanent magnets and arranged in said rows at the same pitch as said permanent magnets, said permanent magnets and said electric windings constituting the rotor and stator members, respectively, of said "brushless" electric motors, each of said rows of permanent magnets and of electric windings constituting a rotor or stator pole, respectively, said electric windings being coupled to a suitable control and power supply electronic circuitry in order to generate rotating electromagnetic fields adapted to rotate the related rotor member by entraining the associated permanent magnets under action of said rotating electromagnetic fields.

Further according to this invention, said sensors are adapted to apply to said control and power supply electronic circuitry all signals needed to synchronize the activation of said stator electric windings to the instantaneous position and speed of said rotor permanent magnets.

Still according to this invention, said rotor and associated stator members are accessible from the external surface of said shell, by removal of suitable sectors of said surface.

Preferably, according to this invention, the internal room of said shell where said rotor and associated stator members are housed is tightly sealed.

Still according to this invention, said rotary electric motors can also be operated as power generators as to supply power to the batteries in watercraft braking situations (regenerative braking action) as well as when the watercraft is propelled by other propulsion means.

Further according to this invention, said shell is adapted to be retracted within the hull of the watercraft.

Further according to this invention, the propulsion apparatus can be provided with two coaxial propellers, each having a rotor member of an electric rotary motor rigidly connected thereto and an associated corresponding stator member, in order that the propulsion thrust is furnished by said two propellers rotating in opposite rotation directions, being driven by said two rotary electric motors rotating in opposite rotation directions.

This invention will be now described by way of illustration and not by way of limitation, according to its preferred embodiments, by particularly referring to the annexed drawings, in which:

Figure 1 is a fragmentary cross-section view of an embodiment of the nautical propulsor according to this invention, and

Figure 2 is a fragmentary cross-section view of another embodiment of the nautical propulsor according to this invention.

By referring now to Figure 1, it can be observed that an embodiment of the nautical propulsor according to this invention comprises a cylindrical shell 1 within which a ducted propeller 2 is arranged.

Preferably, said shell 1 is of the kind well known to

those skilled in the art as Kort shell, having an aerosol wing shaped cross-section with a decreasing diameter from an input leading edge cone 3, at the bow end, to an output trailing edge cone 4, at the stern end. It should be understood, however, that the cross-section shape of this shell 1 can be of a different kind, in order to optimize the propulsion efficiency according to the specific application requirements, without departing from the scope of this invention.

Said shell 1 is integrally connected to a vertical shaft 5, orthogonal to the axis of said shell and rotatively coupled to the watercraft hull 6, in order to operate as a rudderpost. The external portion of said shaft 5 downwardly depending from the boat hull 6 is protected by a first half-fairing 7 integrally connected to said hull 6 and rotatively coupled to said shaft 5, and by a second half-fairing 8, integrally connected both to said shell 1 and to said shaft 5 and rotatively coupled to said first half-fairing.

Said propeller 2 is rigidly connected to a cylindrical tube segment 9 by means of screws 10 which couple the ends 11 of the blades of said propeller 2 to said tube segment 9. Said cylindrical tube segment 9 forms a portion of the inner wall of said shell 1, said tube segment being rotatively coupled to said shell by means of bearings 12, in order to allow said propeller 2 to rotate with respect to said shell 1. It should be understood that said tube segment 9 can have a different shape other than the cylindrical one, provided that it is circularly symmetric, according to the profile shape of the particular shell 1 used in the propulsor. Said bearings 12 are retained in their positions within said shell 1 by means of suitable fastening rings 13, rigidly connected to said shell 1 by means of screws 14.

A vertical blade 15, integrally connected to the inner wall of said trailing cone 4 of said shell 1, acts as a rudder, which directs the water flow and aligns the fluid laminar layers in vortical movement as caused by rotation of the blades of said propeller 2. Said blade 15 can be provided with a suitably shaped projection 16 in corresponding position to the axis of said shell 1, the hub 17 of said propeller 2 being rotatively coupled to said projection.

Said cylindrical tube segments 9 can be provided, within the structure of said shell 1, with permanent magnets 18 rigidly connected thereto, and said magnets can be divided into groups aligned along rows parallel to the axis of said tube segment 9, said rows being preferably arranged at equal distances from one another along the circumference of said tube segment 9. The apparatus further comprises, within the structure of said shell 1, electric windings 19, rigidly coupled to said shell 1 and divided into groups aligned along rows similar to the rows of said permanent magnets 18 and arranged, within said rows at the same pitch and in corresponding positions with respect to said permanent magnets 18.

Said permanent magnets 18 and said electric windings 19, constitute the rotor and the stator members, re-

spectively, of an electric motor of the kind well known to those skilled in the art under designation of "brushless" motor. Each one of said rows of permanent magnets 18 and of electric windings 19 constitutes a pole, namely a motor and a stator pole, respectively, and their number can vary and can also be different in respect of the rotor and stator members, according to the requirements of the application in respect of the speed range and of the torque range to be achieved.

Said electric windings 19 are connected to a control and power supply circuitry, not shown, substantially including power switch transistors, by means of electric conductors arranged within said shaft 5.

Said control and power supply circuitry drives said stator electric windings 19 in such a way as to generate a rotating electromagnetic field that is linked with said rotor permanent magnets 18 and entrains them into rotary motion. Suitable sensors, not shown, supply said control and power supply circuitry with all signals needed to synchronize the activation of said stator electric windings 19 with the instantaneous positions and speeds of said rotor permanent magnets 18. In particular, said sensors either can be housed within the structure of said shell 1 and rigidly connected to said shell 1, or can be arranged on the hub 17 of said propeller and connected to the remainder portion of said circuit by means of electric cables extending within said shaft 5, said blade 15 and said projection 16. This path could be also extended within the blades of said propeller 2 up to said tube segment 9, should a different kind of rotary electric motor be utilized, also provided with electric windings arranged on the rotor member, to furnish power supply to said rotor windings by means of electric connections consisting of cables and/or wipers.

Preferably, said stator electric windings 19 and said rotor permanent magnets 18 are accessible from the external surface of said shell 1, by removal of suitable sectors 20 of said surface. The inner room of said shell 1, where said electric windings 19 and said permanent magnets 18 are housed, is tightly sealed in order to prevent any water seepage.

Said shaft 5 integrally connected to said shell 1 is rotatable with respect to said hull 6 in a range of 0 to 360°, thereby enabling the thrust generated by said propeller to be oriented in any direction. This means that the propulsion apparatus always operates with the same efficiency also when the watercraft carries out turns and/or reverse motion manoeuvres, thereby allowing a complete and ready manoeuvrability.

It is also possible to arrange for the electric motor to be operated as a power generator in order to supply electric power to the batteries, in boat braking situations (regenerative braking action) as well as when the propulsion apparatus according to this invention is utilized as auxiliary motor in sail watercrafts and the watercraft is propelled by wind.

It is also possible to arrange for said shell 1 to be adapted to be retracted within the hull of the boat for

execution of any maintenance operations.

By referring now to Figure 2, it can be observed that the propulsion apparatus according to this invention is provided with two coaxial propellers 2' and 2" arranged as ducted propellers within the same Kort shell 1, each of which is rigidly coupled to permanent magnets 18' and 18", that constitute the rotor members of two "brushless" motors, having corresponding associated electric windings 19' and 19", rigidly connected to said shell 1 and constituting said two "brushless" motors.

This embodiment of the subject nautical propulsor is based upon the same operation principle as the embodiment of Figure 1, but it has the specific characteristic that the propulsion thrust is furnished by two propellers 2' and 2" that rotate in opposite directions, namely they are driven by said two "brushless" motors with opposite rotation directions.

The electric motor provided in the propulsion apparatus according to this invention, preferably of the "brushless" type, is immersed into water and, therefore, during its operation, it is struck by the fluid flow and, therefore, it has the advantage that any heat generated in the windings is dissipated with high efficiency.

An electric motor of the "brushless" type is advantageously utilized in the propulsion apparatus according to this invention in view of the fact that it is extremely simple and sturdy, thereby reducing the maintenance requirements. Furthermore, the low inertia of the rotor member improves the response times in acceleration and deceleration phases and, therefore, it allows to achieve an optimum manoeuvring rapidity in a large range of propeller speed values, as well as rapid inversion times and maximum torque figures over the whole speed range of the boat.

It should also be understood that it is also possible to utilize a rotary electric motor of any other kind, without so departing from the scope of this invention.

The adoption of a shell structure, besides protecting the blades against any possible impacts, allows to noticeably improve the efficiency of the ducted propeller (s), thereby augmenting their thrust and reducing the optimum diameter of the propeller(s).

As far as big watercrafts are concerned, it is possible to utilize a number of nautical propulsors according to this invention, preferably two propulsors, thereby augmenting the resultant cumulative thrust furnished by the propulsion plant.

The preferred embodiments of this invention have been described and a number of variations have been suggested hereinbefore, but it should expressly be understood that those skilled in the art can make other variations and changes, without so departing from the scope of this invention, as defined in the attached claims.

**Claims**

1. A nautical propulsion apparatus consisting of a swinging shell (1) within which one or more propellers (2) are ducted, characterized in that said shell (1) is rigidly connected to a vertical shaft (5) acting as rudderpost and in that said propellers (2) are rotatively coupled to said shell (1) by suitable coupling means (9, 10) and the rotor member (18) of a corresponding electric motor is rigidly connected to each of said propellers (2), the stator member (19) of said electric motor being rigidly connected to said shell (1), so that the rotation of said propellers (2) is rigidly coupled to the rotation of the corresponding rotor member (18), said rotor and stator members (18, 19) being housed within the structure of said shell (1). 5
2. A nautical propulsion apparatus according to claim 1, characterized in that the nautical propulsion apparatus can comprise at least two propellers (2) and the propeller hubs (17) are connected with one another. 10
3. A nautical propulsion apparatus according to claim 2, characterized in that said hubs (17) are rotatively coupled to one another. 15
4. A nautical propulsion apparatus according to claim 2, characterized in that said hubs (17) are rigidly coupled to one another. 20
5. A nautical propulsion apparatus according to any one of the preceding claims, characterized in that said shell (1) is a Kort shell having an aerosol cross-section with a decreasing diameter from an input leading edge cone (3), at the bow end, to an output trailing edge cone (4), at the stern end. 25
6. A nautical propulsion apparatus according to any one of the preceding claims, characterized in that said shaft (5) rigidly connected to said shell (1) is orthogonal with respect to the axis of said shell (1). 30
7. A nautical propulsion apparatus according to claim 6, characterized in that said shaft (5) rigidly connected to said shell (1) can be rotatively coupled to the boat hull (6) with a swinging range of 0 to 360°. 35
8. A nautical propulsion apparatus according to claim 7, characterized in that said shaft (5) rigidly connected to said shell (1) has its portion downwardly depending from the boat hull (6) protected by a first half-fairing (7) integrally connected to said hull (6) and rotatively coupled to said shaft (5) and by a second half-fairing (8) integrally connected to said shell (1) and to said shaft (5) and rotatively coupled to said first half-fairing (7). 40
9. A nautical propulsion apparatus according to any one of the preceding claims, characterized in that said coupling means for connecting said propellers (2) and said shell (1) comprise at least one tubular segment (9) rigidly connected to said propellers (2), by means of screws (10) which couple the suitably shaped ends of the blades of said propellers (2) to said tubular segments (9), said tubular segments (9) matching the profile of said shell (1) so as to form the inner wall of said shell (1), said tubular segments (9) being rotatively coupled to said shell (1) by means of bearings (12) in order to allow said propellers (2) to rotate with respect to said shell (1), said bearings (12) being retained in their positions within said shell (1) by means of suitable fastening rings (13) rigidly connected to said shell (1) by means of screws (14). 45
10. A nautical propulsion apparatus according to any one of the preceding claims, characterized in that said shell (1) is provided with a vertical blade (15) integrally connected to the inner wall of the end portion of said shell (1). 50
11. A nautical propulsion apparatus according to claim 10, characterized in that said vertical blade (15) is provided with a suitably shaped projection (16) in corresponding position to the axis of said shell (1), the hub (17) of any adjacent propeller (2) being rotatively coupled to said projection. 55
12. A nautical propulsion apparatus according to any one of the preceding claims, characterized in that said nautical propulsion apparatus can be provided with position and speed sensors for said rotor members (18). 60
13. A nautical propulsion apparatus according to claim 12, characterized in that said sensors are housed within the structure of said shell (1) and are rigidly connected to said shell (1) as well as to a suitable control and power supply electronic circuitry by means of electric cables extending within said shaft (5) rigidly connected to said shell (1). 65
14. A nautical propulsion apparatus according to claims 11 and 12, characterized in that said sensors are rigidly coupled to the hubs (17) of said propellers (2) and are connected to a suitable control and power supply electronic circuitry by means of electric cables extending within said shaft (5) rigidly connected to said shell (1), within said vertical blade (15) and within said projection (16) of said vertical blade (15). 70
15. A nautical propulsion apparatus according to any one of the preceding claims, characterized in that said stator members (19) are provided with electric 75

windings connected to a suitable control and power supply electronic circuitry by means of electric cables extending within said shaft (5) rigidly connected to said shell (1).

16. A nautical propulsion apparatus according to claim 11 and any one of claims 12 to 15, characterized in that said rotor members (18) are provided with electric windings coupled to a suitable control and power supply electronic circuitry by means of electric connection elements, consisting of cables and/or wipers, extending within said shaft (5) rigidly coupled to said shell (1), within said vertical blade (15), within said projection (16) of said vertical blade (15) and then within the hubs (17) and the blades of said propellers (2).

17. A nautical propulsion apparatus according to claim 15, characterized in that said electric motors are "brushless" motors, in which the rotor member (18) includes permanent magnets and the stator member (19) includes electric windings.

18. A nautical propulsion apparatus according to claims 9 and 17, characterized in that said tubular segments (9) have permanent magnets (18) divided into groups aligned along rows parallel to the axis of said tubular segments (9) integrally connected thereto within the structure of said shell (1), the apparatus further comprising, within the structure of said shell (1), electric windings (19) rigidly coupled to said shell (1) and divided into groups aligned along rows similar to the rows of said permanent magnets (18) and arranged in said rows at the same pitch as said permanent magnets (18), said permanent magnets (18) and said electric windings (19) constituting the rotor and stator members, respectively, of said "brushless" electric motors, each of said rows of permanent magnets (18) and of electric windings constituting a rotor or stator pole, respectively, said electric windings (19) being coupled to a suitable control and power supply electronic circuitry in order to generate rotating electromagnetic fields adapted to rotate the related rotor member by entraining the associated permanent magnets (18) under action of said rotating electromagnetic fields.

19. A nautical propulsion apparatus according to claims 12 and 17, characterized in that said sensors apply to said control and power supply electronic circuitry all signals needed to synchronize the activation of said stator electric windings (19) to the instantaneous position and speed of said rotor permanent magnets (18).

20. A nautical propulsion apparatus according to any one of the preceding claims, characterized in that said rotor (18) and associated stator (19) members

are accessible from the external surface of said shell (1), by removal of suitable sectors (20) of said surface.

5 21. A nautical propulsion apparatus according to any one of the preceding claims, characterized in that the internal room of said shell (1) where said rotor and associated stator members (18, 19) are housed is tightly sealed.

10 22. A nautical propulsion apparatus according to any one of the preceding claims, characterized in that said rotary electric motors are adapted to be operated as power generators as to supply power to the batteries in watercraft braking situations (regenerative braking action) as well as when the watercraft is propelled by other propulsion means.

15 23. A nautical propulsion apparatus according to any one of the preceding claims, characterized in that said shell (1) is adapted to be retracted within the hull of the watercraft.

20 24. A nautical propulsion apparatus according to any one of the preceding claims, characterized in that the propulsion apparatus is provided with two coaxial propellers (2', 2''), each having a rotor member (18', 18'') of an electric rotary motor rigidly connected thereto and an associated corresponding stator member (19', 19''), in order that the propulsion thrust is furnished by said two propellers (2', 2'') rotating in opposite rotation directions, being driven by said two rotary electric motors rotating in opposite rotation directions.

25

30

35

40

45

50

55

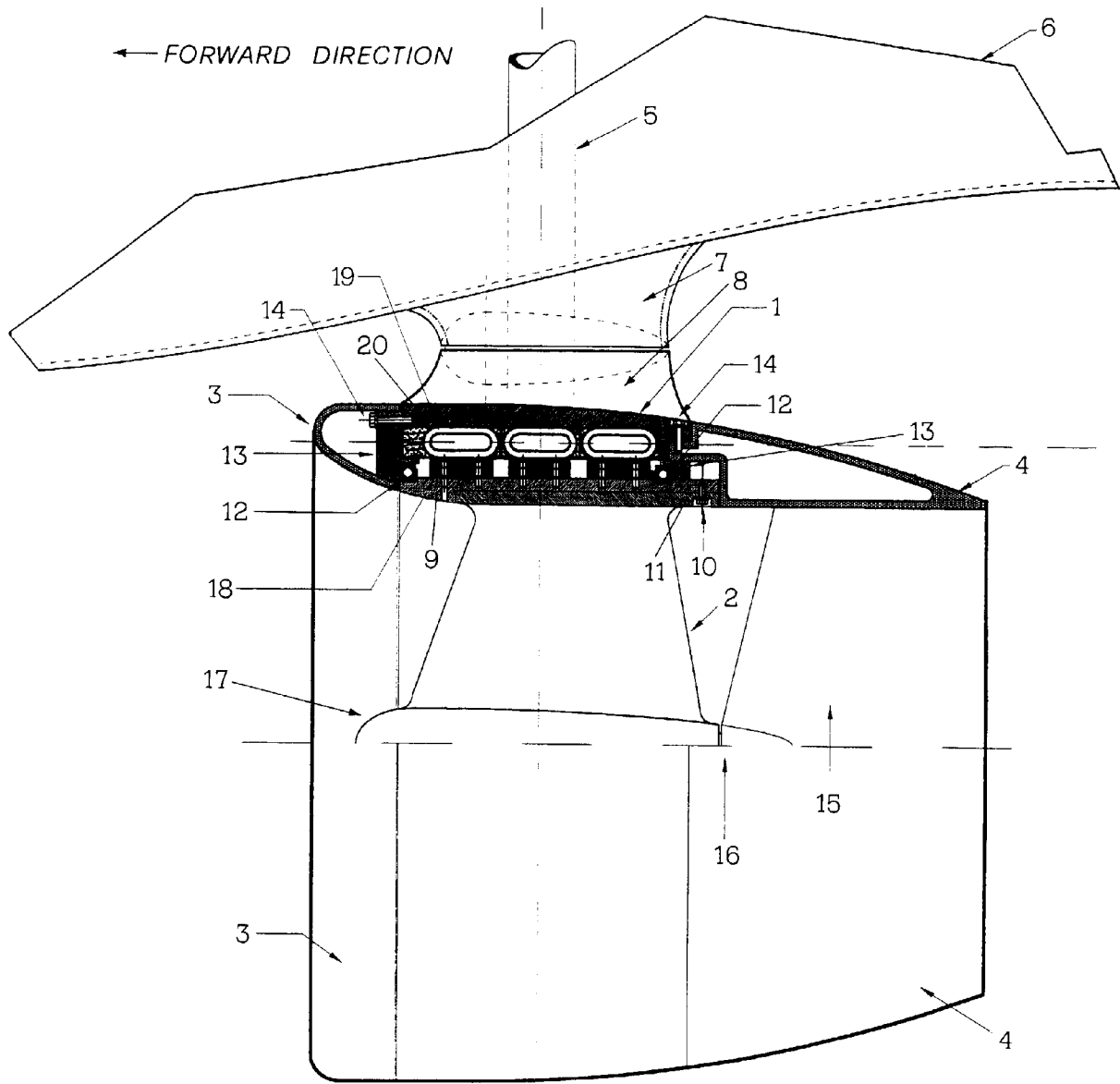

FIG. 1

FIG. 2

