

(19)



Europäisches Patentamt
European Patent Office
Office européen des brevets



(11)

EP 0 876 970 A1

(12)

EUROPEAN PATENT APPLICATION

(43) Date of publication:
11.11.1998 Bulletin 1998/46

(51) Int Cl.6: B65F 1/10, B65F 1/14

(21) Application number: 98201266.8

(22) Date of filing: 20.04.1998

(84) Designated Contracting States:
**AT BE CH CY DE DK ES FI FR GB GR IE IT LI LU
MC NL PT SE**
Designated Extension States:
AL LT LV MK RO SI

(72) Inventors:
• **Doekele, Rienstra**
1393 PX Nigtevecht (NL)
• **de Graaf, Peter**
3603 AP Maarsse (NL)

(30) Priority: 18.04.1997 NL 1005838

(74) Representative: **Land, Addick Adrianus Gosling
Arnold & Siedsma,**
Advocaten en Octrooigemachtigden,
Sweelinckplein 1
2517 GK Den Haag (NL)

(71) Applicants:
• **Bammens B.V.**
NL-3604 BA Maarsse (NL)
• **Diftar B.V.**
3542 AC Utrecht (NL)

(54) System and method for collecting waste material, as well as a suitable collector therefor

(57) System for collecting waste, comprising:

- one or more containers (1) with an insertion opening (4) lockable by means of locking means (5) for depositing waste in the container;
- control means (6) connected to the locking means for controlling the locking means with a key or code

(9);

- transfer means (14,15) connected to the control means for transferring information obtained by the control means; and
- a processing unit (10, 11, 12, 16) placed at a distance from the containers for processing the information generated by the control means.

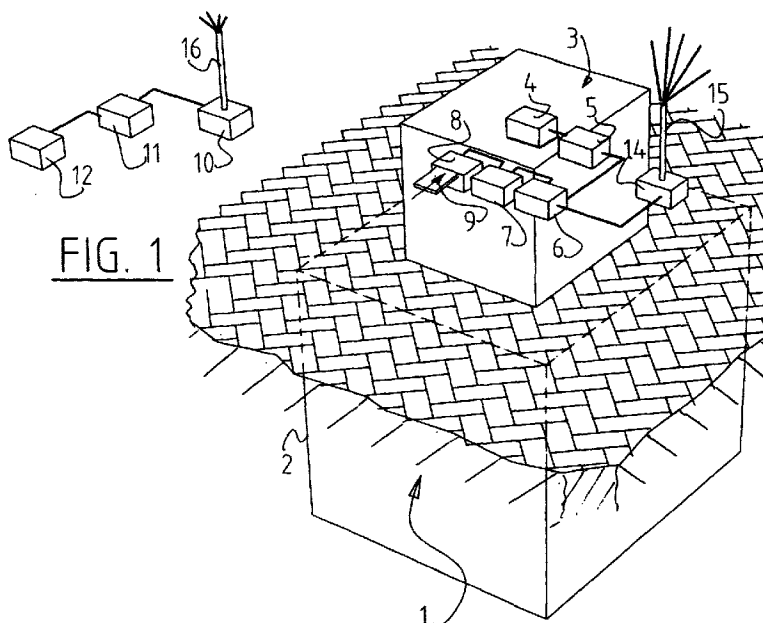

FIG. 1

EP 0 876 970 A1

Description

Particularly in the Netherlands, but also elsewhere, containers are being placed on or partly below the public highway on an increasingly large scale, into which containers must be deposited domestic waste, which may or may not be separated in fractions. The separate collection of glass in glass containers and paper in waste paper containers has in any case proven to be a great success in the Netherlands.

Tests have also been carried out in the Netherlands with differentiated charges, i.e. the refuse collection rate charged to households is made dependent upon the amount of waste presented, and/or the type of waste such as glass, waste paper or KGW (Kitchen and Garden Waste), textile, remaining waste et cetera. Households are hereby further motivated to produce little waste and/or to separate it into the correct fractions. In such systems it is also possible, for instance when a determined quantity of paper is deposited in the paper container, to give a bonus herefor.

However, however, because the behaviour of people is not always predictable, it frequently occurs that such containers placed on or below the public highway become overfull, i.e. a waste heap forms round such containers. This is of course undesirable from an environmental viewpoint, while it moreover entails a great deal of work for the cleansing service.

The present invention has for its object to obviate such problems and provides for this purpose a system for collecting waste, comprising;

- one or more containers with an insertion opening lockable by locking means for depositing waste in the container;
- control means connected to the locking means for controlling the locking means with a key or code;
- transfer means connected to the control means for transferring information obtained by the control means; and
- a processing unit placed at a distance from the containers for processing the information generated by the control means.

In a first preferred embodiment the key or code is a contact-free, for instance inductive card, such as is known for access security of buildings and the like. It is however likewise conceivable for the card to be provided with a magnetic strip or chip, such as is known for bank cards. Such systems cannot however withstand vandalism so well. The data transfer between control means and the collector preferably takes place via the data network known as "RAM Mobile data".

In a further preferred embodiment the power supply for the transfer means at the container also takes place in contact-free, for instance inductive, manner, wherein in a further preferred embodiment the container is preferably provided with an accumulator for storing and sup-

plying sufficient power, for instance 20 Watt, to the transfer means.

According to a further aspect of the present invention, a system for collecting waste is provided, comprising:

- one or more collecting containers for collecting waste;
- transfer means for transfer of information concerning the status of the collecting containers; and
- a processing unit placed at a distance from the containers for processing the status information.

The status information relates for instance to the degree of filling of the container, for which purpose this latter can be provided with sensors, such as ultrasonic sensors, for determining the degree of filling, for instance with an accuracy of four levels. In this more rudimentary embodiment of the present invention accumulation of waste close to the waste containers is avoided, since the central processing unit can pass on timely instructions to the cleansing department to empty a waste container in question.

The present invention further provides a method for use of the system and an (underground) container.

The present invention will be further elucidated on the basis of the following description of a preferred embodiment thereof, with reference to the annexed figures, wherein:

fig. 1 is a diagram of a first embodiment of a system according to the present invention;

fig. 2 shows a perspective view of the above-ground part of a collector for use in the system according to the present invention;

fig. 3 shows a schematic view in cross-section of the collector shown in fig. 2; and

fig. 4 shows a perspective view of the central control unit for use in the system according to the present invention.

A preferred embodiment of a container 1 (fig. 1) comprises an underground part 2 and an above-ground part 3, wherein an insertion opening 4 is arranged in the above-ground part. Insertion opening 4 can be closed using a flap (not shown), which is operated from an electro-mechanical locking member 5 which is also connected to an interface 6. Also connected to interface 6 is a reading apparatus 7 which is provided with a slot 8 into which a card 9 can be placed.

After insertion of card 9 the flap is released, whereafter the holder of the smart card can throw waste into the insertion opening. The quantity of deposited waste is registered and is either deducted from the balance of the smart card or charged to a periodic invoice. It is likewise conceivable to make a distinction between private and professional users. Present for instance on a company card is a balance which is debited, while private

persons obtain an access card for access to the container by paying a standing charge.

Also connected to interface 6 is a transmitter/receiver 14 with antenna 15, which can communicate via an antenna 16 with a transmitter/receiver 10 which is connected via interface 11 to a central computer 12. By means of communication between central computer 12 and container 1 the degree of filling of the container can be determined and it can be emptied in timely manner, whereby accumulation of waste is prevented. Nor is it necessary for officials to read the data on site from the electronics of the container. If the data is transmitted directly to the central computer, no data will be lost in the case of vandalism and the like. Finally, using reverse transmission from the central computer, it is possible to envisage keeping the flap of the container locked for a time in order to prevent it becoming overfull before being emptied.

Transmission preferably takes place wirelessly and the power supply to the electronics of the computer also takes place wirelessly, i.e. inductively, so that when the container is emptied no additional operations have to be performed and it can simply be lifted out of the ground and emptied in known manner, for instance via the underside.

A collector 1 (fig. 2, 3) which is suitable for instance for remaining waste is provided above-ground with an electrically lockable flap 21 and is likewise provided above-ground with an antenna 22 for information transfer with the central processing unit. In this preferred embodiment the flap is preferably opened by holding an inductively operating card adjacently of the flap. As in the previous preferred embodiment, the balance can be deducted from the card or invoicing can take place later.

As shown particularly in fig. 3, the underground part 2 of collector 1 is placed in a concrete casing 23. When collector 1 is hoisted out for emptying thereof, a floor 24 automatically moves upward in order to prevent the possibility of passers-by then falling into the concrete casing, which may have a depth of several metres. On the concrete casing 23 a schematically designated inductive element 24 is connected to a schematically designated alternating voltage source, for instance the mains voltage. Further arranged on the underground part 2 is an inductive element 25 for taking up electrical power induced by element 24, for instance with a power of 20 Watt. Element 25 is further connected to an accumulator 26 to supply sufficient power for instance during peak load, such as transmitting information through antenna 22. Connected to accumulator 26 and the receiving inductive element 25 are schematically designated electronics 27, which are connected on the other hand to the locking mechanism for flap 21 and a schematically designated sensor element 28.

In a further preferred embodiment the system according to the present invention is provided with a column 30 (fig. 4) comprising two uprights 31, 32 as well as an antenna 33. Between uprights 31 and 32 is ar-

ranged a housing with the electronics 33 as well as a keyboard 34 in front of which the transponder card is held and for keying in a container to be used. A number of collectors, for instance 6-10, are then connected to this column 30 in a manner not shown, for instance for different types of waste, such as KGW, glass, textile and the like.

In the latter preferred embodiment, one antenna 33 can suffice for the desired number of collectors, which is favourable from a cost viewpoint and which makes data transmission easier and less expensive.

The present invention is not limited to the above described preferred embodiment; the rights applied for are defined by the following claims, within the scope of which many modifications can be envisaged.

Claims

1. System for collecting waste, comprising;
 - one or more containers with an insertion opening lockable by locking means for depositing waste in the container;
 - control means connected to the locking means for controlling the locking means with a key or code;
 - transfer means connected to the control means for transferring information obtained by the control means; and
 - a processing unit placed at a distance from the containers for processing the information generated by the control means.
2. System as claimed in claim 1, wherein the transfer means comprise at least one transmitter and at least one receiver.
3. System as claimed in claim 1, wherein the transfer means comprise a modem.
4. System as claimed in claim 1, 2 or 3, wherein at least a considerable part of the container extends under the ground surface.
5. System as claimed in any of the foregoing claims, wherein the containers are provided with a hoist engaging member for hoisting thereof out of an outer casing.
6. Method for collecting waste wherein a system is used as claimed in any of the foregoing claims.
7. Container of which at least a considerable part extends underground, evidently intended for a system as claimed in any of the claims 1-5 and provided with transfer means for transferring obtained information to the central processing unit.

8. System for collecting waste, comprising:

- one or more collecting containers for collecting waste;
- transfer means for transfer of information concerning the status of the collecting containers; and
- a processing unit placed at a distance from the containers for processing the status information.

10

15

20

25

30

35

40

45

50

55

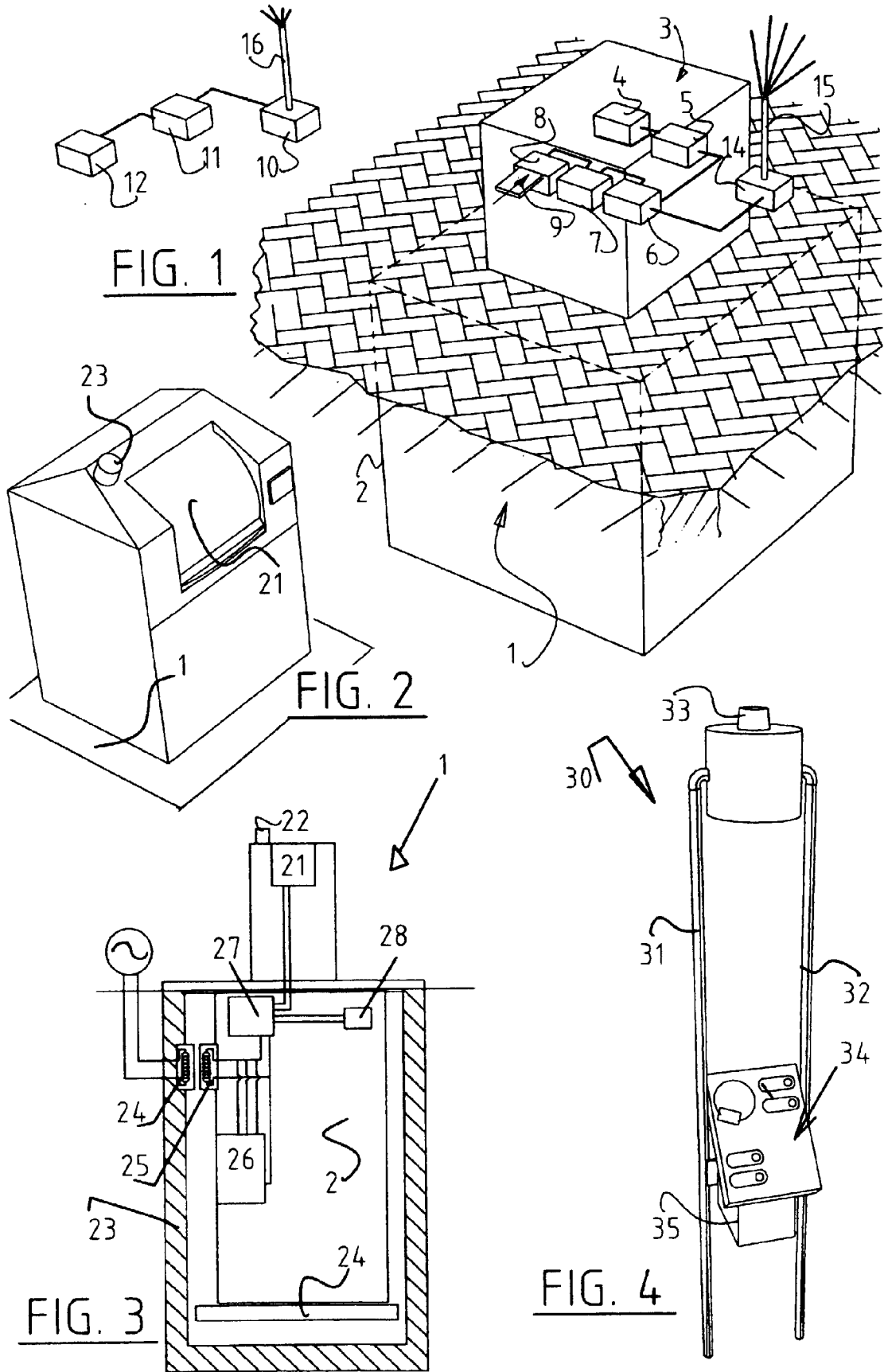



European Patent Office

EUROPEAN SEARCH REPORT

Application Number
EP 98 20 1266

DOCUMENTS CONSIDERED TO BE RELEVANT			
Category	Citation of document with indication, where appropriate, of relevant passages	Relevant to claim	CLASSIFICATION OF THE APPLICATION (Int.Cl.6)
X	WO 96 22238 A (TECNOCAD SRL) 25 July 1996 * page 10, line 9 - page 17, line 12 * * figures 9,10 * ---	1-8	B65F1/10 B65F1/14
X	DE 296 02 267 U (ALOIS PÖTTINGER MASCHINENFABRIK GMBH) 25 April 1996 * page 6, line 1 - page 8, line 31 * * figures 1-4 * ---	1,2,6,8	
X	DE 43 41 899 A (U. PUHAN) 21 September 1995 * column 3, line 67 - column 4, line 60 * * column 5, line 20 - column 6, line 29 * ---	1,2,6,8	
X	DE 43 21 754 A (DEUTSCHE AEROSPACE AG) 23 February 1995 * column 1, line 67 - column 3, line 65 * * figure 1 * ---	8	
A		1-3,6,7	
X	DE 44 11 478 A (KRONE AG) 24 November 1994 * column 3, line 25 - column 5, line 3 * * figures 1-5 * -----	8	
A		1-3,6,7	TECHNICAL FIELDS SEARCHED (Int.Cl.6) B65F
The present search report has been drawn up for all claims			
Place of search THE HAGUE		Date of completion of the search 20 July 1998	Examiner Smolders, R
CATEGORY OF CITED DOCUMENTS X : particularly relevant if taken alone Y : particularly relevant if combined with another document of the same category A : technological background O : non-written disclosure P : intermediate document T : theory or principle underlying the invention E : earlier patent document, but published on, or after the filing date D : document cited in the application L : document cited for other reasons & : member of the same patent family, corresponding document			

EPO FORM 1503 03/82 (P/4/C01)