



Europäisches Patentamt
European Patent Office
Office européen des brevets



(11) **EP 0 878 216 A1**

(12) **EUROPEAN PATENT APPLICATION**
published in accordance with Art. 158(3) EPC

(43) Date of publication:
18.11.1998 Bulletin 1998/47

(51) Int. Cl.⁶: **A63B 23/04, A63B 23/00**

(21) Application number: **97900109.6**

(86) International application number:
PCT/JP97/00023

(22) Date of filing: **09.01.1997**

(87) International publication number:
WO 97/25107 (17.07.1997 Gazette 1997/31)

(84) Designated Contracting States:
CH DE FR GB IT LI

(72) Inventors:
• **KASUGA, Hiroshi**
Hirakata-shi, Osaka 573-01 (JP)
• **YOSHIMURA, Shinichiro**
Kobe-shi, Hyogo 655 (JP)

(30) Priority: **11.01.1996 JP 2931/96**
23.07.1996 JP 193274/96

(74) Representative:
Sherrard-Smith, Hugh
Appleyard Lees,
15 Clare Road
Halifax, HX1 2HY, West Yorkshire (GB)

(71) Applicant: **Kasuga, Hiroshi**
Hirakata-shi, Osaka 573-01 (JP)

(54) **KICKING TYPE TRAINING APPARATUS**

(57) A kicking type training apparatus for use in increasing the isometric muscle strength of the abdominal muscles and back muscles by backward kicking of lower limbs. This apparatus is provided with a body (1), a saddle (3) fixed to the body (1), and a load generator adapted to apply a load on both lower limbs of the user when these limbs act thereon. The load generator includes a pair of tread rods (30) adapted to receive both feet of the user and be moved back by the alternate backward kickings of both lower limbs of the user, and an air cylinder (2a) adapted to impart a load with respect to the backward movements of the foot rods (30), and automatically return forward these stepping means (30) when the foot rods (30) are released from the stepping force. The user sits on the saddle (3), holds grips (5d) by hand, and applies the abdomen and elbows to an abdomen support pad (18) and elbow support pads (19), respectively. The user, in this condition, kicks the foot rods (30) by the left and right lower limbs alternately. The air cylinder (2a) generates a load with respect to the stepping motions of the lower limbs. This effectively increases the isometric muscle strength of the back muscles and abdominal muscles.

Fig. 1

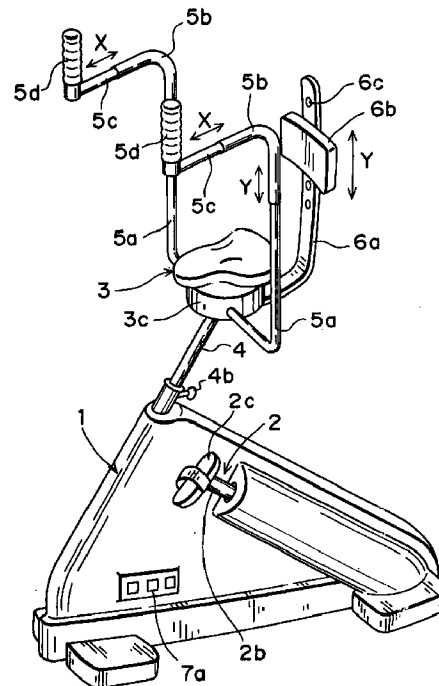

EP 0 878 216 A1

Description

TECHNICAL FIELD

The present invention relates to kick type training equipment intended for enhancement of the isometric muscular strength of the group of back muscles and the group of abdominal muscles on the basis of a novel principle of muscular exercise. More particularly, the invention relates to kick type training equipment designed mainly for kick motion, i.e., backward linear or circular-arc reciprocating motion of the legs, as against conventional stationary bicycling equipment designed mainly for rotational motion of the legs.

BACKGROUND ART

Whereas varieties of training equipment intended for enhancement of the cardiopulmonary function as well as enhancement of muscles have become popular in recent years, these varieties of equipment are targeted principally for healthy persons. Most units of training equipment installed in gymnasias of fitness clubs are those optimum for currently active sportsmen to build up a stronger body.

However, major part of people who set their mind on physical exercise after becoming a working member of society could be said to be semi-healthy. Such people are exemplified by those having orthopedic past histories such as lumbago and gonalgia, those having internal past histories such as hypertension and diabetes, and those who worry about fatness and cholesterol level. In this sense, there is an urgent need for development of training equipment suited for semi-healthy people.

For the development of training equipment targeted for semi-healthy people, it is of great importance to have a viewpoint of enhancing the isometric muscular strength (i.e., muscular strength for support of the skeleton). It has been clarified medically that the diseases typified by lumbago and gonalgia develop when the isometric muscular strength is lowered. It is known that a major cause of adult diseases is decreased basal metabolic rate, which in turn is also due to lowered isometric muscular strength.

Although a large number of units or systems of training equipment for training the isotonic muscular strength (i.e., muscular strength to do exercises) have been available hitherto, equipment for training the isometric muscular strength has been nonexistent so far.

DISCLOSURE OF THE INVENTION

Therefore, a principal technical object of the present invention is to provide novel training equipment for enhancing isometric muscular strength, in particular, the isometric muscular strength of the group of back muscles and the group of abdominal muscles, which are

the major cause of the lumbago.

Another object of the invention is to provide training equipment capable of training the isometric muscular strength reasonably even with semi-healthy people or those having diseases in the waist or the knees.

A further object of the invention is to provide training equipment which allows improvement in the cardiopulmonary function as well as improvement in the basal metabolic rate to be achieved more efficiently than conventional stationary bicycling equipment, and which also allows the energy consumption to be calculated with high accuracy.

Still another object of the invention is to provide training equipment which allows adjustment and enhancement of the isotonic muscular strength of the femoral region and the lower legs, which are the major cause of the gonalgia, to be effectively achieved in addition to the enhancement of the isometric muscular strength.

Still another object of the invention is to improve the cooperativity between the group of muscles of the leg region and the group of back muscles during an exercise and, in particular, to provide training equipment capable of improving the motional cooperativities between the group of coxal muscles and the other groups of muscles, i.e., between the group of coxal muscles and the group of back muscles, between the group of coxal muscles and the group of iliolumbar muscles, and besides between the group of coxal muscles and the group of femoral-region muscles, respectively.

In order to achieve the above objects, according to the present invention, there is provided kick type training equipment having the following constitution.

This kick type training equipment comprises a body implemented by a frame or pedestal seat or the like, a saddle which is fitted to the body and on which a user is to be seated, and load generating means for, when the user's both legs act thereon, giving a load to both legs. The load generating means comprises a pair of stepping means, i.e. step rods or pedals, on which the user's both feet are placed and which are moved in an identical direction by backward alternate kick motions of the user's both legs, and load means such as an air cylinder or a weight for imparting a load to backward movement of the stepping means, i.e. generally horizontally backward movement or obliquely downward backward movement or generally obliquely upward backward generally linear or circular-arc movement of the stepping means, and for, upon cancellation of stepping force on the stepping means, automatically returning the stepping means forward, and preferably, promptly.

The user, seated on the saddle, simply steps in on the stepping means alternately with the two legs to continue the exercise for a certain time. By doing this stepping exercise on the stepping means, the isometric muscular strength of the group of back muscles can be trained, while the isometric muscular strength of the group of abdominal muscles can also be trained in con-

junction with this. That is, this muscle strengthening exercise is not an exercise that directly stresses the back muscles or abdominal muscles but an exercise capable of indirectly training the back muscles or abdominal muscles by substantially linear, simple kick motion which is a back-and-forth or up-and-down motion of the legs. Further, there is no need of taking a forward-tilted posture, which is a bad leg position as seen in the conventional stationary bicycling equipment, i.e., a position in which the trunk is bent forward with respect to the lumbar or pelvis, so that the user is allowed to do exercise in a good leg position. In other words, with the conventional stationary bicycling equipment, because the user's upper half of the body, i.e., the trunk portion is bent forward as against the waist portion in the upright posture on the saddle, the waist portion would be burdened with unreasonable force, causing the muscles around the spine to be excessively stressed, thus resulting in muscle fatigue. By contrast, with the training equipment of the present invention, when the trunk portion is bent forward, also tilting forward the waist portion responsively, i.e., tilting forward the whole body allows the user to be in a good leg position.

Also, according to the training equipment of the present invention, the kick motion along the major axis of a lower leg becomes substantially a pendulum motion with the articulation of the hip taken as a fulcrum. The drive force outputted from the user depends largely on movement of the center of gravity of the trunk portion which is effected while the leg muscles are kept in a certain tension matching the load, so that the knee joint and the ankle joint can be maintained at a substantially constant joint angle in spite of the exercise that burdens the leg. Therefore, muscle motions can be effected while the motions of those joints are largely avoided. Normally, the pain on motion occurs when the joint has excessively moved.

Accordingly, even if the back muscles and the abdominal muscles are of poor power, and even if any disease in the waist portion is involved, the kick motion can be easily performed without burdening the waist, knees, ankles and the like with unreasonable force, so that their isometric muscular strength can be trained. In addition, this training equipment is similar to the conventional stationary bicycling equipment merely in the sense that the user moves the legs while being seated on the saddle, but differs from that in the motional form of the legs. For the stationary bicycling equipment, it is impossible to effectively train the isometric muscular strength.

In this kick motion along the major axis of the lower legs, forces applied to the joint sites of the knees and the feet are effectively absorbed by the groups of muscles constituting the femoral region and the lower legs, so that the burden applied to those joint sites is greatly reduced. Besides, the kick motion along the major axis of the lower legs is transferred more linearly in the trans-

fer of motional loads to the trunk portion than in the other motional forms. As a result, centripetal information transfer through nerve fibers is transferred to the central nervous system at higher rate. This means that reflex arcs (i.e., a state of coordinated movements of the muscles) are formed faster, which contributes to an improvement of inhibited coordination among the muscle groups.

Further, according to this training equipment, the stepping motion on the stepping means is substantially a linear motion, and not a rotational motion of the pedal as seen in the conventional stationary bicycling equipment. Therefore, the training equipment can be made to keep a continuing load during a step on the stepping means, so that a cardiopulmonary exercise effect can be attained efficiently in shorter time as compared with the stationary bicycling equipment. Further, at the same time, the isotonic muscular strength of the femoral region and the lower legs can be enhanced. In addition, in the case of the conventional stationary bicycling equipment, although the legs are burdened with a load of a specified value during the step motion with the pedal, i.e., the first half of a pedal rotation, the pedal puts into inertial rotation, i.e., is burdened with extremely decreased load during the second half of the pedal rotation, resulting in a great exercise loss and hence insufficient exercise efficiency, where longer exercising time would be involved to obtain enough cardiopulmonary exercise effect.

It is noted that the kick motion of the stepping means is a motion along the major axis of the lower legs, which includes, needless to say, a motion along a straight line literally, and besides motions along curves or circular arcs which are more or less curved, naturally. In short, the kick motion is only required to be one that allows the user's legs to give a kick backward substantially linearly.

For this training equipment, preferably, the kick motions of the legs are performed in such a way that an angle formed by the trunk and the femoral region falls within a range of 100° to 220° with the user seated on the saddle. The smaller this angle becomes, the more the spine is deformed linearly so that stress occurs to the back muscles, unfavorably for those having lumbar. Although varying among individual users, when the angle is over approximately 100° to 110°, almost no such stress occurs, making the exercise reasonable. In addition, the angle of 180° means an upright state with the body stretched to the full, while greater angles mean a state of bent body. In the kick motion of the legs, upon a backward kick on the stepping means, the user's legs move to the angle of about 220°, although varying among individual users. This kick motion of the legs is approximate to a walking motion of the legs in the climbing on a slanted slope. In order to make the angle within the aforementioned range, it is preferable to provide guide means for guiding the movement of the stepping means so that the conditions are satisfied.

The guide means may be either a means for guiding the stepping means backward substantially along a line or a means for guiding the stepping means backward along a circular arc.

The guide means may be a swing arm with a balance weight coupled to its upper end, in which case the upper end of the swing arm is pivotally fitted to the saddle or at a substantially saddle level of the body and the stepping means is pivotally fitted to a lower end of the swing arm. With this arrangement, since the distance between the user's waist portion and the stepping means is maintained substantially constant during the stepping motion on the stepping means, the bending angle of the knees is kept constant accurately.

Also in order to satisfy the above conditions, preferably, the training equipment further comprises means for adjusting the position (back-and-forth position, up-and-down position) of the saddle. It is preferable that the kick motion of the legs is performed so that the angle formed by the trunk and the femoral region falls within a range of 100° to 220° with the user seated on the saddle, by adjusting the saddle position according to the user's physique. The saddle position adjusting means may be, simply, of a system that a saddle support bar is fixed to the body by a height adjustment screw or a height adjustment pin, or otherwise a system that the saddle support bar is moved up and down by a hydraulic lifting device.

Further, in order to satisfy the conditions, preferably, the training equipment further comprises handgrip means which is gripped by the user seated on the saddle at both hands to stably support the user's trunk portion. For backward kick motion of the legs, it is natural that the trunk portion tends to move forward as a reaction of the kick motion. This handgrip means serves as one means for supporting this reactive force. This handgrip means may comprise a grip to be gripped directly by hand, and arms for supporting the grip in such a way that the grip is adjustable in height position and back-and-forth position.

In addition to this handgrip means, preferably, the training equipment further comprises belly support means for supporting the user's trunk portion in a forward tilted posture. Preferably, the belly support means comprises a belly support pad, forward tilt angle adjusting means for adjusting a forward tilt angle of the pad, and besides means for adjusting height of the pad. This belly support pad is most effective in performing kick motion of the legs while supporting the forward tilted trunk portion.

Further, in addition to this belly support pad, even more effectively, the belly support pad also comprises an elbow support pad for supporting the user's elbow.

Further, favorably, the load generating means comprises second guide means for guiding the stepping means so that a bending angle of knees is kept substantially constant during a step on the stepping means. With this arrangement, because almost no bending and

stretching exercises occur, the knees are not burdened so that even those having diseases in the knees are allowed to do exercises easily.

Further, preferably, the saddle comprises a saddle body, a saddle support base for supporting the saddle body upward, and swing means which is placed between the saddle body and the saddle support base and which swings right and left in subordination to right-and-left swinging motion of a waist portion that occurs during the alternate kick motions of the user's legs. This swing means may be implemented simply by a plate spring or a coil spring, or otherwise may be provided in a hydraulic-electric system using an air spring. Also, the saddle body may be made from a flexible material including a gel substance. With such an arrangement, the pedaling exercise can be easily done without causing any unreasonable force to occur to the waist portion. Moreover, by the waist portion swinging along with a step with the pedal, the bending angle of the knees can be maintained constant more easily.

In order to stably support the back portion of the user seated in the saddle, the training equipment may comprise backrest means. This backrest means favorably comprises a backrest pad and an arm for supporting the backrest pad in such a way that the backrest pad is adjustable in height position.

Preferably, the load generating means comprises control means for making the load during a step on the stepping means substantially constant, and for, upon a cancellation of the pedal stepping force, automatically returning the piston rod to an up position along with the stepping means. However, from the viewpoint of simplicity of the kick motion of the legs, it is preferable that the load is gradually increased and afterwards gradually decreased between initial stage and final stage of the step, where a step initial load and a step final load are given as small ones.

Training equipment as a preferred embodiment of the load generating means comprises a pair of swing arms which have the stepping means fitted at their lower ends, respectively, and upper ends of which are pivotally fitted to the saddle or at a substantially saddle level of the body, and a belt which is driven by swinging motion of the swing arms and an end portion of which is connected to the load means. The load means may be a pneumatic or hydraulic cylinder, or further a weight which has conventionally been used for this type of training equipment.

Further, as a preferred embodiment, the training equipment may further comprise plate cam means which is rotated along with rotation of the upper ends of the swing arms, where an end of the belt is fixed to the plate cam means and set along a cam peripheral surface while the other end of the belt is led to the load means by the plate cam means, wherein the cam peripheral surface of the plate cam means has such a configuration as to control the load during a step on the stepping means so that the load is gradually increased

and afterwards gradually decreased between initial stage and final stage of the step within a substantially fixed range, where a step initial load and a step final load are given as small ones.

The control means preferably further comprises means for adjusting the step load on the stepping means. This is intended for the matching to the physical strength of the user.

The load means is ordinarily an air cylinder. The load means may be a coil spring or other elastic means, a hydraulic device or a weight as described above, but is preferably an air cylinder which uses air pressure. In the case of an air cylinder, it is technically easy to make up an arrangement that the piston rod is instantaneously returned to the initial position along with the stepping means when the pedal stepping force is canceled. It is also easy to give an arrangement that while the load during a step on the stepping means is kept at a substantially constant value, the piston rod is cooperated with control means which automatically and resiliently returns the piston rod to the initial position together with the stepping means upon a cancellation of the stepping force on the stepping means. With an arrangement that the stepping means is promptly returned to the initial position, the number of steps on the stepping means per unit time can be increased so that efficient exercise can be achieved in terms of time, advantageously. Also, whereas continuously applying a constant load is pointed out as one important element of muscle strengthening exercise, the load that is kept substantially constant during a step with the pedal meets this condition. Furthermore, in this case, the energy consumption of the exercise, i.e., the work load can be calculated with high accuracy. That is, it can be calculated accurately by a calculational expression, "load (force) × exercised distance". For recent years' training equipment of this type, the expression of energy consumption per unit time has become important. In addition, in the conventional stationary bicycling equipment, the energy consumption could not be calculated accurately because of considerably varying loads during the pedal's rotation.

The air cylinder preferably comprises a cylinder body, a piston and a piston rod, the cylinder body comprising an inner cylinder for housing therein the piston and the piston rod so as to allow them to reciprocatingly slide, an outer cylinder which constitutes a double-wall cylinder in combination with the inner cylinder, an upper plate which closes upper ends of inner and outer cylinders and through which the piston rod passes, a bottom plate which seals lower ends of the inner and outer cylinders and which has a freeing port for freeing a bottom portion of an inner cylinder space, and first communicating means for communicating the inner-and-outer cylinder space and the inner cylinder space with each other at their upper portions.

For maintaining a substantially constant load with the use of the air cylinder and during the kick motion of

the legs, it is important that the cylinder's internal pressure is not varied so much by movement of the piston. For this purpose, according to the prior art, it would commonly be necessary to use an air cylinder of large capacity or to prepare a small cylinder and, separately, an air tank communicated therewith. However, according to the cylinder structure of the present invention, a pressure chamber equivalent to the conventional air tank can be ensured between inner and outer cylinders while the volume of the cylinder can be reduced to a sufficiently small one.

The communicating means is ordinarily a through hole formed in an upper portion of the inner cylinder.

For adjustment of the initial pressure of the inner-and-outer cylinder space and the inner cylinder space, it is necessary to further provide pressure adjusting means. This pressure adjusting means includes second communicating means for communicating the inner-and-outer cylinder space with outside, valve means which connects with the second communicating means, an air compressor which connects with the valve means, and pressure control means for controlling the valve means and the air compressor. With this arrangement, the initial pressure within the cylinder can be easily controlled by electrical control means. By contrast, with a weight used, adjustment with the weight needs to be directly done, which is troublesome in handling.

BRIEF DESCRIPTION OF THE DRAWINGS

Preferred embodiments of the present invention are illustrated in the accompanying drawings, in which

Fig. 1 is a general perspective view of kick type training equipment according to a theoretical embodiment of the present invention;

Fig. 2 is a state-of-use view showing a state in which the training equipment of Fig. 1 is in use, where the user is shown schematically;

Fig. 3 is an explanatory view illustrating kick motion with the training equipment of Fig. 1, where the user is shown schematically;

Fig. 4 is a rear view of a saddle of the training equipment of Fig. 1;

Fig. 5 is an explanatory view showing main part of kick type training equipment according to a modification of the first embodiment of the invention;

Figs. 6, 7 and 8 are a front view, a right side view and a plan view showing whole training equipment according to a second embodiment of the present invention;

Figs. 9 and 10 are a right side view and a rear view showing main part of a saddle and positional adjusting means therefor, respectively, in the second embodiment;

Fig. 11 is a right side view showing main part of a belly support pad and positional adjusting means therefor, respectively, in the second embodiment;

Fig. 12 is a sectional view of an air cylinder of the second embodiment;

Fig. 13 is an explanatory view showing the configuration of a cam, and a belt to be pulled up by the cam in the second embodiment;

Fig. 14 is a graph showing the relationship between the load given to the user's legs and the rotational angle of the legs in the second embodiment; and

Fig. 15 is an explanatory view illustrating the kick motion in the second embodiment.

BEST MODE FOR CARRYING OUT THE INVENTION

Concrete embodiments of the invention will be described in detail below with reference to the accompanying drawings.

Figs. 1 to 4 show whole kick type training equipment according to a theoretical first embodiment of the present invention. As illustrated, this equipment has a saddle 3 provided above a pedestal-formed body 1. As shown in Figs. 2 and 3, the user, sitting on the saddle 3, exercises kick motions, i.e. pedaling motions, on a pair of pedal means attached to the body 1, more specifically pedals 2c, thus performing the training.

The saddle 3 is so constructed that a saddle body 3a is supporting on a saddle support base 3c via three coil springs 3b. Fig. 4 shows a state in which the saddle is viewed from the rear side, where the coil springs 3b are so placed that one is at a front center of the saddle, the other two are on right and left in the rear of the saddle. Accordingly, the saddle body 3a can be swung back and forth, right and left, with respect to the saddle support base 3c.

On the right and left of the saddle 3, are provided a pair of handgrip means 5a - 5d for supporting the user's trunk portion H2 during the training. Each handgrip means comprises an arm part 5a - 5c fixed on the right and left of the saddle support base 3c, and a grip 5d supported by the arm part. The arm part comprises an L-shaped first arm portion 5a fixed directly to the saddle support base 3c, a second arm portion 5c for supporting the grip 5d in an upright posture, and an elbow-shaped third arm portion 5b for connecting the two arm portions 5a, 5c so that the arm portions 5a, 5c are adjustable in height. The arms 5b, 5c can be slidably adjusted in position in directions of arrows Y and X, which in turn allows the grip 5d to be adjusted in height position and back-and-forth position.

In the rear of the saddle 3, is provided backrest means for supporting the user's trunk portion H2 from the back side during the training. This backrest means comprises an L-shaped backrest arm 6a which connects directly to the saddle support base 3c, and a backrest pad 6b which is fitted to the arm so as to be adjustable in height. The backrest arm 6a has a plurality of screw holes 6c for use of height adjustment, so that the pad 6b can be fixed to a height position favorable to the user by using a height adjustment screw 6d.

The saddle 3 is supported to the body 1 so as to be adjustable in height position via a support rod 4. An upper end of the support rod 4 is fixed to the bottom face of the saddle support base 3c, while a lower end of the support rod 4 is inserted into an insertion opening 1c formed in a front upper portion of a body cover 1a. A plurality of screw holes 4a are formed in the support rod 4, and the support rod 4 is fixed so as to be adjustable in height position at the place of the insertion opening 1c with a height adjustment screw 4b.

The body 1 has a pair of air cylinders 2 provided on right and left of the body, the air cylinders 2 being load generating means which supports the pedals 2c and which allows the user's legs to perform kick motion substantially along a line, obliquely downward and backward. Each air cylinder 2 has a cylinder 2a and a piston rod 2b, and the pedal 2c is rotatably attached to a fore end of the piston rod 2b within a certain angular range. The cylinder 2a and the piston rod 2b are installed so as to be tilted obliquely from front upward to rear downward as shown in the figure. This tilt angle is so set that the user's pedal stepping motion is made appropriately.

In Fig. 2, reference numeral 7 denotes a control unit 7 schematically. This control unit itself is a known one and the air cylinder itself equipped with this control unit is also a known one. This control unit allows the load during a step on the pedal to be normally maintained substantially at a constant value, and upon cancellation of the pedal stepping force, allows the piston rod to be automatically returned to an up position resiliently along with the pedal. This means that the load is substantially constant without variations during a step on the pedal at any position in the step stroke.

The control unit 7 connects with an outside control panel 7a. This control panel 7a is provided on a lower side face of the body cover 1a in the figure, but may also be provided on the grip 5d or positioned in front of the user seated with some special support means. By operating this control panel, the load of the air cylinder 2 can be adjusted in magnitude. Further, by connecting a device for detecting the user's heart rate (not shown) to the control unit 7, it becomes also possible to automatically control the load of the air cylinder depending on the heart rate.

Now, the kick type training equipment of the above structure is explained as to the way of use with reference to Fig. 3. The user adjusts the saddle position according to his or her own build, and besides adjusts the load of the air cylinders according to his or her physical strength, physical conditions and the like. After that, the user is seated on the saddle 3 with the back against the backrest pad 6b, and starts an alternate pedaling exercise of the legs while gripping a pair of grips 5d by both hands. Fig. 3 shows a step in which the legs go down from the up position toward the down position substantially along a straight line during the course of a step on the pedal. In the up position, an angle $\theta 1$ formed by the trunk portion H2 and the femoral region H3 is

preferably about 100° to 120°. Although the angle θ_1 at the down position may be 180°, the angle is set to an angle larger than 180° in the figure (up to about 220° is possible). This angle setting depends on the setting of the height position of the saddle 3 as well as the settings of the up position and the down position of the pedal 2c. Also, the bending angle θ_2 of a knee H1 is favorably approximately 90°, and this angle θ_2 is preferably kept unchanged during the stroke from up position to down position. Accordingly, the tilt angle of the cylinder 2 is set so as to satisfy this requirement. Further, because the saddle body 3a is swingable right and left as described before, the waist is allowed to move up and down in a vertical direction Y in response to the step on the pedal, so that the bending angle θ_2 of the knees can be maintained substantially constant.

The pedal stepping exercise is done by moving both legs alternately. During the exercise, the user can stably hold the trunk portion H2 by gripping the grip 5d and by putting the back against the pad 6b. By doing pedal stepping exercise in this way, the user is trained in the group of back muscles and the group of abdominal muscles, in particular, isometric muscular strength among them in leakage with up-and-down oblique movement of the legs. Of course, since the legs themselves are burdened with loads, the isotonic muscular strength of the femoral region H3 and a lower leg portion H4 is trained simultaneously.

This kick type training equipment allows the exercise to be done while the user is in a good leg position with the trunk portion upright on the saddle (a posture at the angle θ_1 of 90° or more with the back muscles free from any wasteful stress), thus easing the exercise itself. Also, because the pedaling exercise is basically an up and down motion with the waist portion free from any unreasonable force, and moreover because no joint motion of the knees is involved when the bending angle θ_2 of the knees is maintained constant, even those having waist diseases or knee diseases are enabled to do this exercise easily.

The above embodiment is of the type that the piston rods 2b of the air cylinders 2 are kicked obliquely downward along a straight line. However, for the present invention, the direction of kick is not necessarily required to be along a straight line in a geometrically strict sense. Fig. 5 shows a modification example in which the direction of kick of the piston rod 2b could be a substantially linear, downward and backward direction but, in the geometrically strict sense, is an obliquely downward and backward direction along a curve or circular arc.

This modification example is similar in basic structure to the first embodiment but differs therefrom in the following points. That is, each pedal 2c is pivotally fitted to the fore end of the piston rod 2b and besides pivotally fitted to a lower end of a swinging arm 8. An upper end of this arm 8 is pivotally fitted to a pivot shaft P5 at a proper place of the saddle 3. When the pedal 2c is

stepped, the arm 8 entirely swings on a fulcrum of the pivot shaft P5 along a circular arc P2 like a pendulum. Accordingly, the pedal 2c moves this circular arc P2.

Meanwhile, the air cylinder 2 has a rear end of a cylinder 2a pivotally fitted to the body 1 by a pivot shaft P4 so as to follow the circular-arc movement of the pedal 2c. Accordingly, responsive to the position of the pedal 2c on the circular arc P2, the entire air cylinder 2 swings in a direction of arrow P3 as required.

According to the constitution of this modification example, since the moving locus of the pedal 2c is restricted by the circular arc P2, which is the locus of swing of the arm 8, and besides since the pivot shaft P5 of the arm 8 is pivotally fitted to the saddle 3 so as to be close to the waist portion of the user, the distance between the waist portion and the pedal 2c is kept substantially constant. Therefore, this modification example has an advantage that the bending angle θ_2 of the knee H1 is maintained more constant and unlikely to vary, as compared with the case of the first embodiment, i.e., the case where a straight line P1 is the moving locus of the pedal. Further, the movement of the pedal is smoother in this case than when it is along a straight line.

Next, a second embodiment of the present invention is described with reference to Figs. 6 to 15. This second embodiment is a further improvement of the first embodiment so as to be more convenient to use.

In this embodiment, the body 1 is implemented by a frame. This frame comprises a pair of side face stands 1d, one central front stand 1m, an upper frame and a bottom frame. The upper frame comprises a front frame member 1j, and left and right frame members 1k, 1i coupled to the left and right of the frame member 1j, respectively. Meanwhile, the bottom frame comprises a front frame member 1f, a rear frame member 1h, and left and right frame members 1e, 1g coupled to the left and right of these frame members 1f, 1h, respectively. Upper and lower ends of the central front stand 1m connect with the front frame members 1j, 1f located in an upper portion and a bottom portion, respectively.

Reference numeral 3 in the figures denotes a saddle. This saddle 3 is placed at a substantially center portion of the frame body 1, and comprises a saddle body 3a and a saddle support base 3c provided below the saddle body 3a. The saddle body 3a is made by filling urethane foam or a gel substance or other flexible material in the surface cover. These flexible materials fulfill functions equivalent to those of the coil springs 3b of the first embodiment. The saddle 3 is supported on the frame body so as to be adjustable in height position via a support rod 4. That is, a saddle supporting frame member 1n extends from an intermediate portion of the central front stand 1m toward the rear side, and as well shown in Figs. 9 and 10, a saddle support bar 1p is telescopically inserted into the frame member 1n. Then, the support rod 4 is inserted from above into a through hole of a block 4c fixed to the fore end of the saddle support bar 1p. The support rod 4 has an appropriate

number of height adjustment holes 4a, while the block 4c has an insert pin 40b for those holes 4a. Similarly, the saddle support bar 1p also has an appropriate number of distance adjustment holes 1q, while the saddle supporting frame member 1n has a pin 4d to be inserted into these holes 1q. As a result, the saddle can be adjusted in its height position and horizontal back-and-forth position.

On the upper front side of the upper frame, is provided a support plate 22, on which a right-and-left pair of grips 5d, a right-and-left pair of elbow support pads 19 and one belly support pad 18 are supported. One end of the support plate 22 is pivotally fitted to a guide rod 21. This guide rod 21 is supported by a pair of bearing blocks 20 fixed onto the side-portion supporting frame member 1k. Therefore, the support plate 22 is enabled to open by pivoting upward about an axis of the guide rod 21, and moreover to slide along the guide rod 21. The other end of the support plate 22, on the other hand, is supported on the side frame member 1i. A pin plate 22a is fixed to the lower face of the other end of the support plate 22. This pin plate 22a is a clearance adjustment plate having a pin (not shown) projected from its lower face. This pin can be fitted into a pin hole 22b formed in a linear shape at the top surface of the side frame member 1i, and is capable of the back and forth positioning of the support plate 22. In addition, each grip 5d is fixed to the support plate 22 via the arm 5c so as to be adjustable in height.

The belly support pad and each elbow support pad 19, as well shown in Fig. 15, effectively support the trunk portion H2 of the user seated on the saddle 3 in a forward tilted posture. Each elbow support pad 19 is supported on the support plate 22. Meanwhile, the belly support pad 18, as shown in detail in Fig. 11, has a bracket 18a fixed in a central upper portion of a rear face of the pad 18, and an upper portion of a support stand 23 is pivotally fitted to the bracket 18a. Then, the support stand 23 extends vertically through the support plate 22. The support stand 23 has an appropriate number of height adjustment holes 23a, each of which is designed for insertion of a pin 24. The pin 24 is inserted therein via an insertion hole formed in the support plate 22. As a result, the belly support pad 18 can be adjusted in height position. Meanwhile, reference numeral 26 in the figures denotes a pair of adjustment screws for adjusting the tilt angle of the belly support pad 18. Each adjustment screw 26 is screwed into a screw hole provided in the support plate 22 so that its fore end makes contact with a lower portion of the rear face of the pad 18. By these adjustment screws 26 moving back and forth, the pad 18 is rotated about a fulcrum of an upper portion of the support stand 23 so as to be adjusted in its tilt angle. In addition, this embodiment is designed for the user to exercise kick motion in a forward tilted posture as stated before and therefore the backrest means seen in the first embodiment is excluded.

In this embodiment, a pair of step rods 30 are adopted as the stepping means. These step rods 30 are fixed to lower ends of the right and left pair of swing arms 8. The step rods 30 extend horizontally inward from the swing arms 8, left and right, respectively. Each step rod 30 has a stopper 10. The user's feet are to be placed inside these stoppers 10. When each rod is stepped backward, the feet would tend to slide outward so as to be opened outward, but are blocked from being opened by the stoppers 10. An upper end of each swing arm 8 is fixed to its corresponding shaft 11. These shafts 11 are rotatably provided at upper portions of the side stands 1d, respectively. The shafts 11 extend through from inside to outside of the stands 1d, respectively. The swing arms 8 are fixed inside the shafts 11, respectively. Meanwhile, a cam 14 and a balance weight 13 are fixed on each shaft 11 outer than the stand. This balance weight 13 serves for weight adjustment to balance the weights of the swing arm and the step rod so that the step load becomes substantially zero.

The shape of each cam 14 is shown in detail in Fig. 13. This cam is a plate cam, which is substantially elliptically shaped as a whole and has a base end fixed to the shaft 11. Flanges 14a are provided on both sides of a free end of the cam, with a cam groove formed between the flanges 14a. An end of a belt 17 is fixed to this cam. That is, the belt 17 is set on the free-end peripheral surface of the cam and a fixed end 17a of the belt 17 is fixed to the cam peripheral surface.

The belt 17 is connected to each air cylinder 2 via a pulley 16. This pulley 16 is shaft fitted to rear portions of the side frame members 1i, 1k and outside them. The air cylinders 2 are arranged in a way largely different from that of the first embodiment, and fixed vertically onto the bottom frame. An end portion of the belt 17 is coupled to an upper end of the piston rod 2b of each air cylinder 2. Accordingly, if the user kicks each step rod 30 backward by the leg as shown in Fig. 15, the belt 17 is pulled forward so that the piston rod 2b is pulled up.

How the configuration of the cam 14 gives a load to the legs during the kick motion is described below with reference to Figs. 13 and 14.

Fig. 13 shows a case in which the cam, the initial position of which is at an angle of 45° on the basis of a horizontal axis, has rotated 90° counterclockwise in the figure along with the swing arm by kick motion. When the cam 14 has a configuration of a cam peripheral surface as illustrated in the figure, the relationship between the kick angle and a load applied to the leg results in a curve as shown in the graph of Fig. 14. That is, the load is substantially constant as a whole, but gradually increases from the initial stage of a kick motion and thereafter gradually decreases toward the final stage of the kick motion. This is because the elliptical configuration of the cam causes the distance between the cam peripheral surface and the shaft 11 to vary so that the traveling length of the belt 17 per unit rotational angle of

the cam is varied. As a result, the kick motion can be done smoothly. More specifically, in the initial stage of a kick motion, the load is made relatively small so as to allow an easy step. Then, as the step is accelerated, the load is increased gradually. In the final stage of the kick motion, the user would get into a posture that the legs are bent toward the back side with respect to the trunk portion, thus being hindered from exerting force. On account of this, in the final stage, the load is made relatively small.

Next, the structure of the air cylinder 2 is described in detail with reference to Fig. 12.

The air cylinder 2 comprises a cylinder body 2a, a piston 2f and a piston rod 2b. The cylinder body is of a double wall structure, i.e., its cylindrical body is composed of an inner cylinder 2m and an outer cylinder 2c. The inner cylinder, which is equivalent to a conventional cylinder body, houses therein the piston 2f and the piston rod 2b, allowing them to slidably reciprocate. The outer cylinder 2c, on the other hand, defines an inner-and-outer cylinder space 2p against the inner cylinder 2m. In an upper portion of the inner cylinder 2m, an appropriate number of through holes 2n are formed so as to communicate an inner cylinder space 2q and the inner-and-outer cylinder space 2p with each other. Upper and lower ends of the inner and outer cylinders are sealed by their top plates 2d and a bottom plate 2e. The bottom plate 2e has a freeing port 2g for freeing the bottom portion of the inner cylinder space 2q to outside, and pressure adjusting means for adjusting initial pressures of the inner-and-outer cylinder space 2p and the inner cylinder space 2q. In order to communicate the inner-and-outer cylinder space 2p with outside, this pressure adjusting means comprises an air-pressure adjustment port 2h formed in the bottom plate 2e, a valve 2j which connects with the port 2h, an air compressor 2k which connects with the valve 2j, and pressure control means, i.e. a control panel 7b, for controlling the valve 2j and the air compressor 2k. The control panel 7b is fixed to the front frame member 1j.

The double wall structure of the cylinder body as described above means ultimately to eliminate the air tank and to downsize the air cylinder. This air cylinder is made smaller in the capacity of the inner cylinder and larger in the capacity of the outer cylinder. Assuming that the through holes 2n are absent with the result of closure, up and down movement of the piston caused by the user's kick motion makes the piston move up and down within the inner cylinder 2m so that the pressure in the inner cylinder is varied. That is, the pressure grows larger in proportion to increases in the stepping amount of the kick motion. In such a case, it would be impossible to exercise a smooth kick motion. Therefore, any extreme pressure increase in the inner cylinder needs to be prevented. Conventionally, this would be implemented by using an air tank to be connected to the inner cylinder. In contrast to this, this air cylinder employs the outer cylinder 2c instead of an air tank. That is, because

the inner cylinder space 2q communicates with the inner-and-outer cylinder space 2p via the through holes 2n, pressure variation in the inner cylinder space is absorbed by fluid present in the inner-and-outer cylinder space of large capacity, so that the quantity of variation can be suppressed to a negligible level depending on the design of the cylinder. Besides, because the through holes 2n can be enlarged enough in their opening area and also set in their number and configuration arbitrarily, the air passage resistance of the through holes 2n can be reduced to small enough so that the variation in pressure change can be reduced to an extremely small one, as an advantage. With the conventional air tank used, quite a large resistance of the pipe that connects the air tank and the air cylinder with each other would cause larger pressure variations as compared with the air cylinder of this embodiment.

Claims

1. Kick type training equipment comprising:

a body (1);
 a saddle (3) which is fitted to the body (1) and on which a user is to be seated; and
 load generating means for, when the user's both legs act thereon, giving a load to both legs, wherein
 the load generating means comprises:

a pair of stepping means (2c, 30) on which the user's both feet are placed and which are moved in an identical direction by backward alternate kick motions of the user's both legs; and
 load means (2a) for imparting a load to backward movement of the stepping means (2c, 30) and for, upon cancellation of stepping force on the stepping means (2c, 30), automatically returning the stepping means (2c, 30) forward.

2. The training equipment according to Claim 1, wherein the load generating means further comprises first guide means (2, 8) for guiding the stepping means (2c, 30) so that the kick motions of the user's legs are performed while an angle ($\theta 1$) formed by a trunk portion (H2) and a femoral region (H3) falls within a range of 100° to 220° with the user seated on the saddle (3).

3. The training equipment according to Claim 2, wherein the first guide means (2) guides the stepping means (2c) backward substantially along a line.

4. The training equipment according to Claim 2, wherein the first guide means (8) guides the step-

ping means (30) along a circular arc.

5. The training equipment according to Claim 4, wherein the first guide means (8) comprises a swing arm, and wherein an upper end of the swing arm (8) is pivotally fitted to the saddle (3) or at a substantially saddle level of the body (1) and the stepping means (2c) is pivotally fitted to a lower end of the swing arm (8). 5
6. The training equipment according to Claim 5, wherein a balance weight (13) is coupled to the upper end of the swing arm (8). 10
7. The training equipment according to Claim 1, wherein the load generating means comprises second guide means (2, 8) for guiding the stepping means (2c, 30) so that a bending angle (θ_2) of knees is kept substantially constant during a step on the stepping means (2c, 30). 15 20
8. The training equipment according to Claim 1, further comprising handgrip means (5a - 5d) which is gripped by the user at both hands to stably support the user's trunk portion (H2). 25
9. The training equipment according to Claim 8, wherein the handgrip means (5a - 5d) comprises a grip 5d to be gripped directly by hand, and arms (5a - 5c) for supporting the grip in such a way that the grip is adjustable in height position and back-and-forth position. 30
10. The training equipment according to Claim 1, further comprising adjustment means (4, 4a, 4b, 4c, 4d, 1p, 1q) for adjusting the position of the saddle (3). 35
11. The training equipment according to Claim 1, further comprising belly support means (18, 22, 23, 24, 26) for supporting the user's trunk portion (H2) in a forward tilted posture, wherein the belly support means comprises a belly support pad (18) and forward tilt angle adjusting means (22, 23, 24, 26) for adjusting a forward tilt angle of the pad (18). 40 45
12. The training equipment according to Claim 1, further comprising an elbow support pad (19) for supporting the user's elbow. 50
13. The training equipment according to Claim 1, wherein the saddle (3) comprises a saddle body (3a), a saddle support base (3c) for supporting the saddle body upward, and swing means (3b) which is placed between the saddle body and the saddle support base and which swings right and left in subordination to right-and-left swinging motion of a waist portion that occurs during the alternate kick

motions of the user's legs.

14. The training equipment according to Claim 1, wherein the saddle (3) comprises a saddle body (3a) and a saddle support base (3c) for supporting the saddle body upward, the saddle body (3a) being formed from a flexible material which can be moved in subordination to the right-and-left swinging motion of the waist portion that occurs during the alternate kick motions of the user's legs.
15. The training equipment according to Claim 1, further comprising backrest means (6a - 6d) for stably supporting back portion of the user seated on the saddle (3).
16. The training equipment according to Claim 15, wherein the backrest means comprises a backrest pad (6b) and an arm (6a) for supporting the backrest pad in such a way that the backrest pad is adjustable in height position.
17. The training equipment according to Claim 1, wherein the load generating means further comprises control means (7) for making the load during a step on the stepping means (2c, 30) substantially constant, and for, upon a cancellation of the pedal stepping force, automatically returning the piston rod (2b) to an up position along with the stepping means (2c, 30).
18. The training equipment according to Claim 17, wherein the control means (7) includes step load increasing and decreasing means (7, 14) for controlling the load during a step on the stepping means (2c, 30) so that the load is gradually increased and afterwards gradually decreased between initial stage and final stage of the step within a substantially fixed range, where a step initial load and a step final load are given as small ones.
19. The training equipment according to Claim 1, wherein the load generating means comprises:
 - a pair of swing arms (8) which have the stepping means (30) fitted at their lower ends, respectively, and upper ends of which are pivotally fitted to the saddle (3) or at a substantially saddle level of the body (1); and
 - a belt (17) which is driven by swinging motion of the swing arms (8) and an end portion of which is connected to the load means (2a).
20. The training equipment according to Claim 19, further comprising plate cam means (14) which is rotated along with rotation of the upper ends of the swing arms (8), where an end of the belt (17) is

fixed to the plate cam means (14) and set along a cam peripheral surface while the other end of the belt (17) is led to the load means (2a) by the plate cam means (14);

wherein the cam peripheral surface of the plate cam means (14) has such a configuration as to control the load during a step on the stepping means (2c, 30) so that the load is gradually increased and afterwards gradually decreased between initial stage and final stage of the step within a substantially fixed range, where a step initial load and a step final load are given as small ones.

21. The training equipment according to Claim 17, wherein the control means (7) further comprises means (7a, 2j, 2k) for adjusting the step load on the stepping means (2c, 30).

22. The training equipment according to Claim 1, wherein the load means is an air cylinder (2).

23. The training equipment according to Claim 22, wherein the stepping means is a pedal (2c), the pedal being fitted to a fore end of the piston rod (2b) of the air cylinder (2).

24. The training equipment according to Claim 22, wherein the air cylinder (2) comprises a cylinder body (2a), a piston (2f) and a piston rod (2b), the cylinder body comprising:

an inner cylinder (2m) for housing therein the piston and the piston rod so as to allow them to reciprocatingly slide;

an outer cylinder (2c) which constitutes a double cylinder in combination with the inner cylinder;

an upper plate (2d) which closes upper ends of inner and outer cylinders and through which the piston rod passes;

a bottom plate (2e) which seals lower ends of the inner and outer cylinders and which has a freeing port (2g) for freeing a bottom portion of an inner cylinder space (2q); and

first communicating means (2n) for communicating the inner-and-outer cylinder space (2p) and the inner cylinder space (2q) with each other at their upper portions.

25. The training equipment according to Claim 24, wherein the first communicating means is a through hole formed in an upper portion of the inner cylinder (2m).

26. The training equipment according to Claim 24, further comprising pressure adjusting means for adjusting initial pressures of the inner-and-outer

cylinder space (2p) and the inner cylinder space (2q).

27. The training equipment according to Claim 26, wherein the pressure adjusting means comprises:

second communicating means (2h) for communicating the inner-and-outer cylinder space (2p) with outside;

valve means (2j) which connects with the second communicating means (2h);

an air compressor (2k) which connects with the valve means (2j); and

pressure control means for controlling the valve means (2j) and the air compressor (2k).

Fig. 1

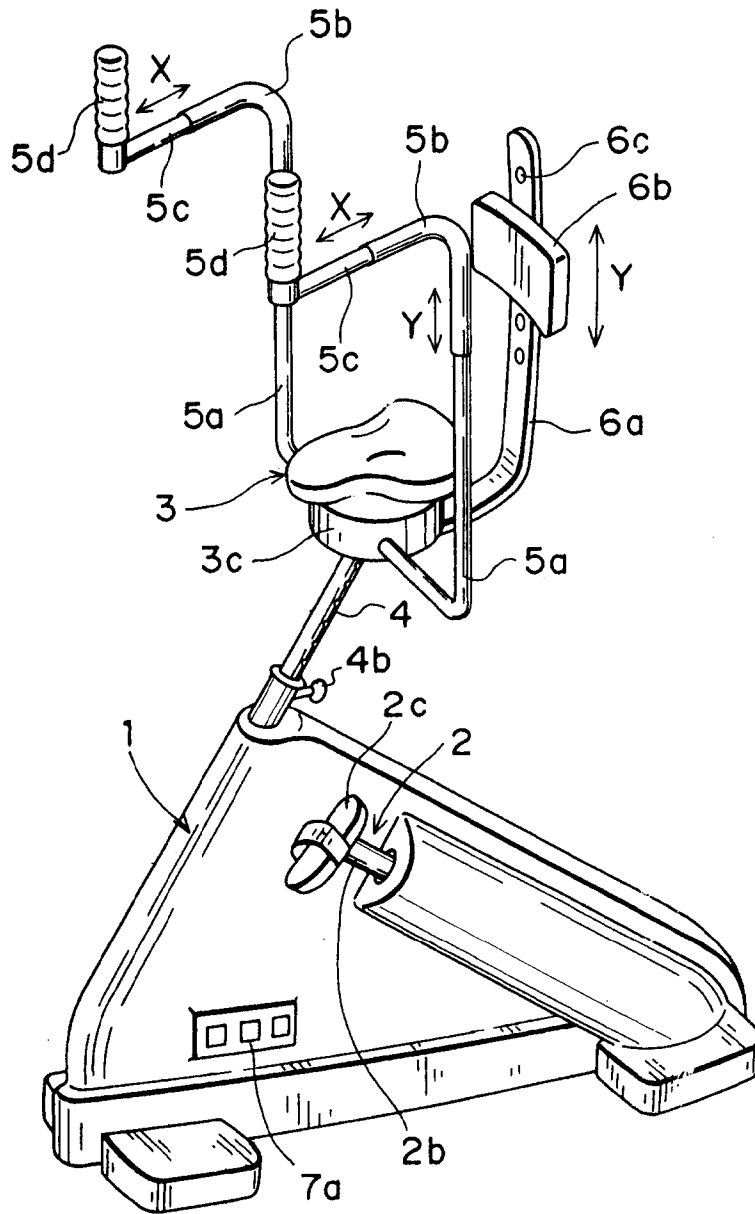

Fig. 3

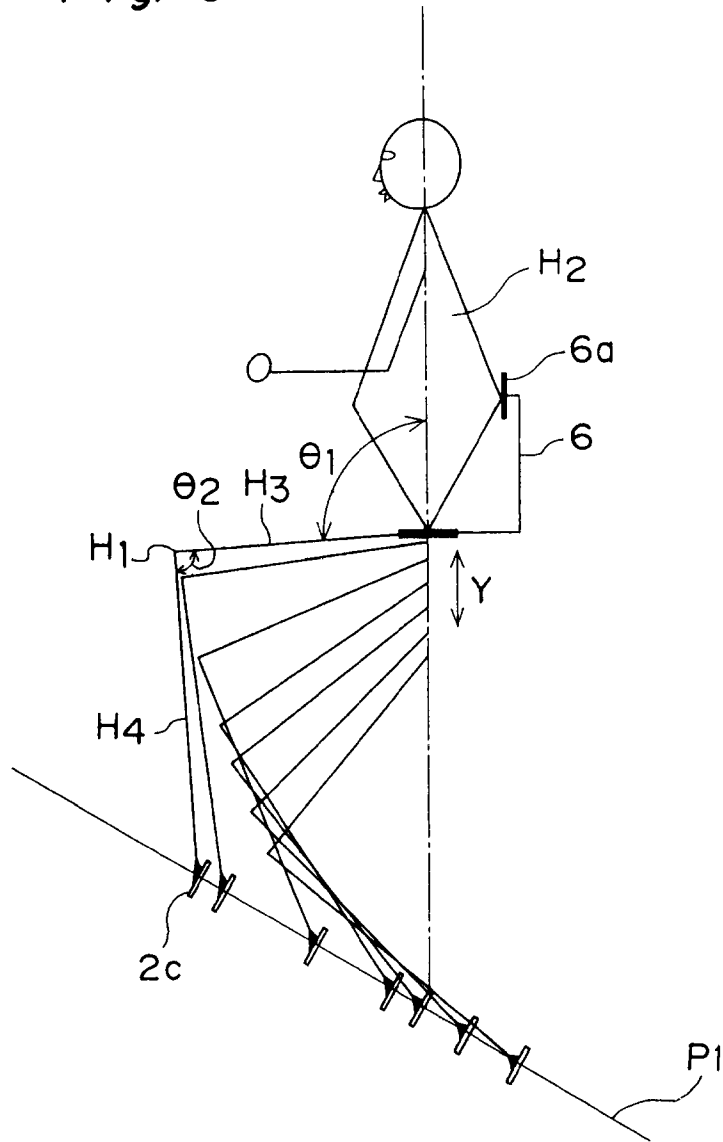

Fig. 4

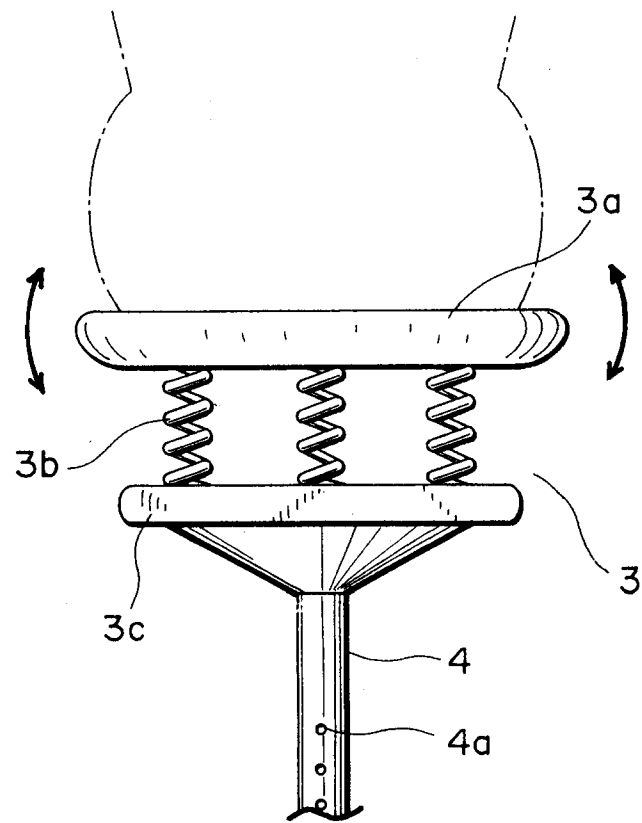

Fig. 6

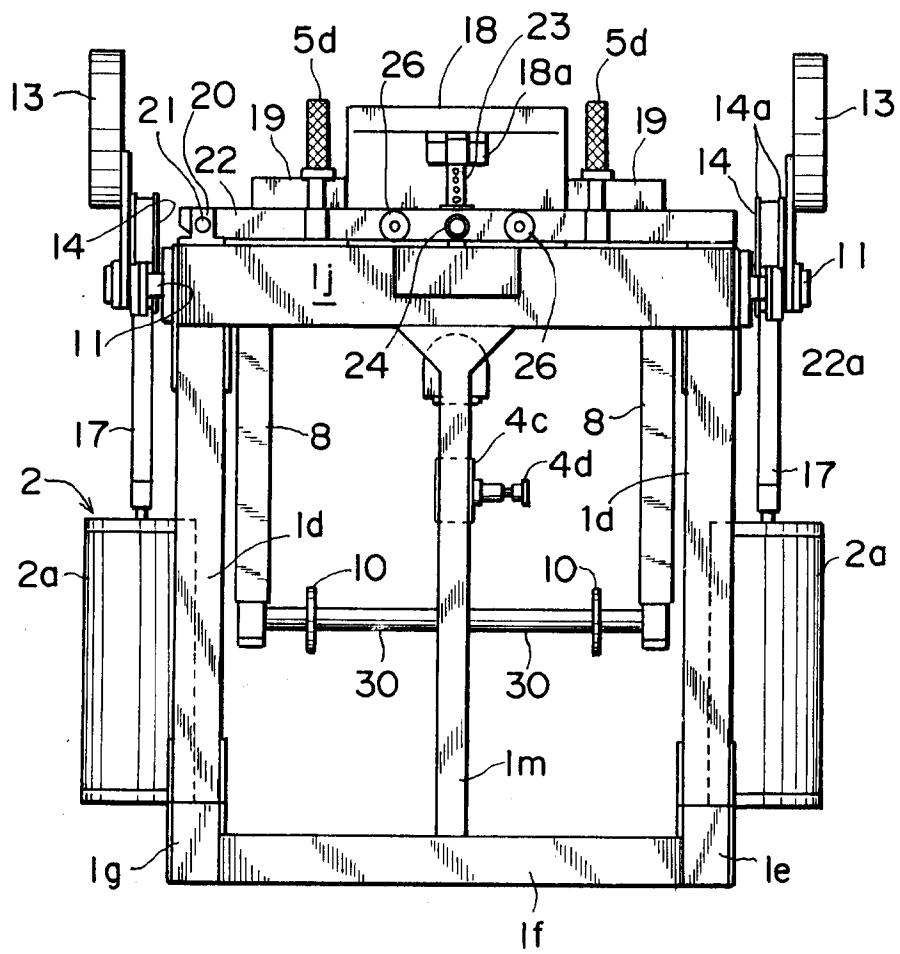

Fig. 7

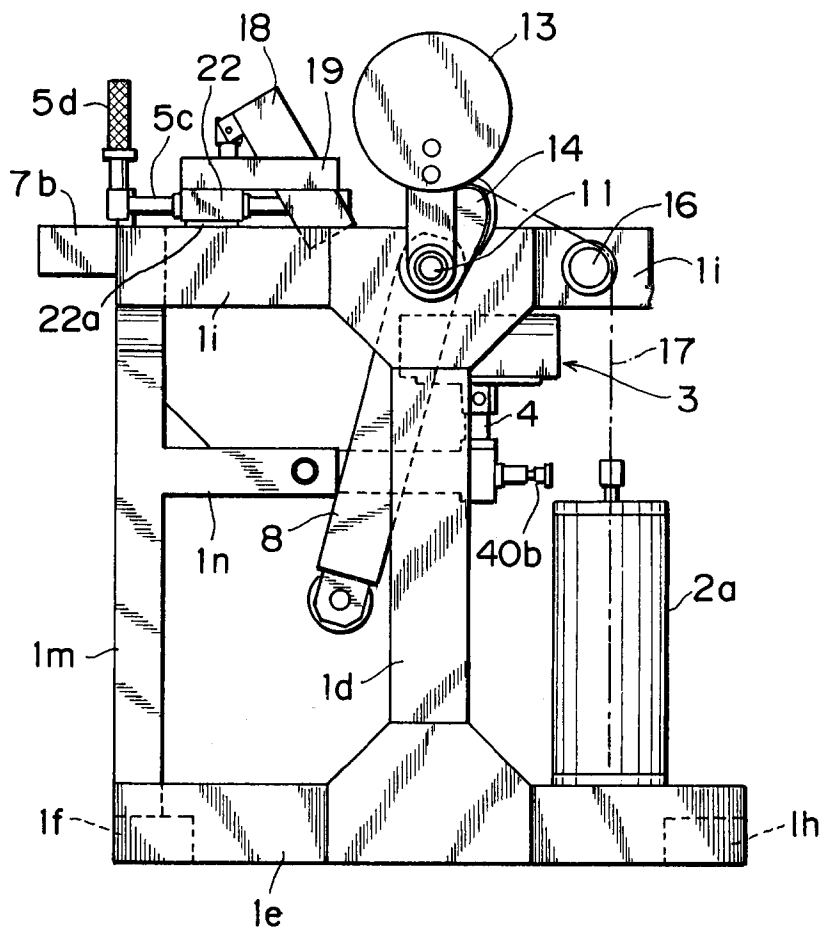

Fig. 8

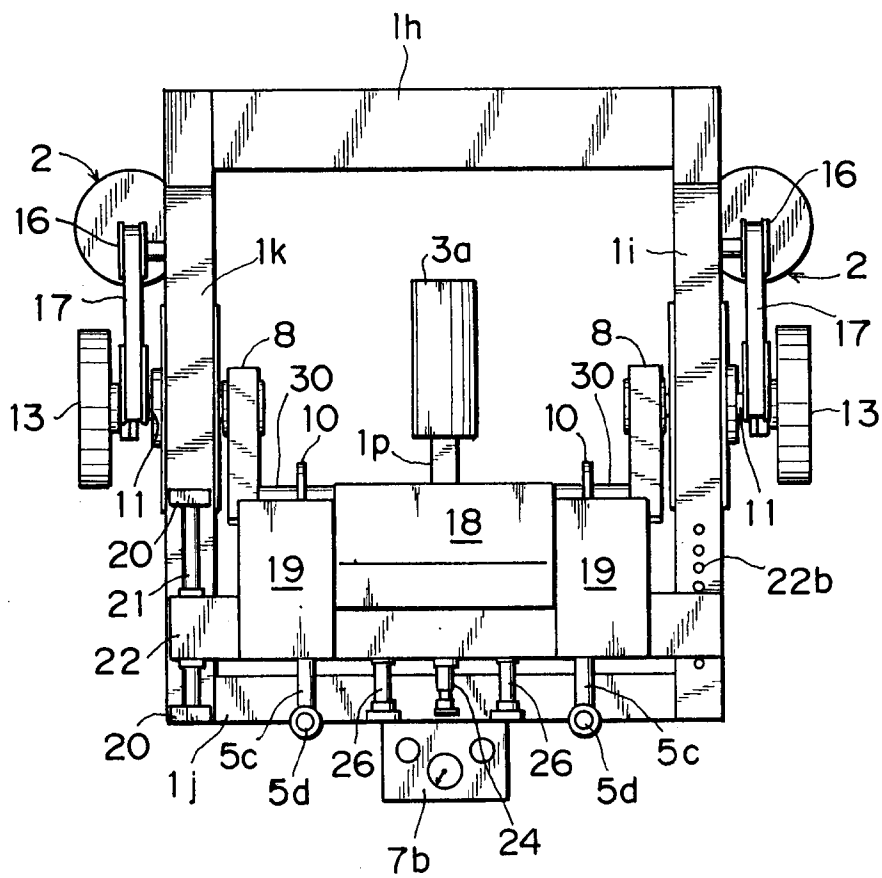

Fig. 9

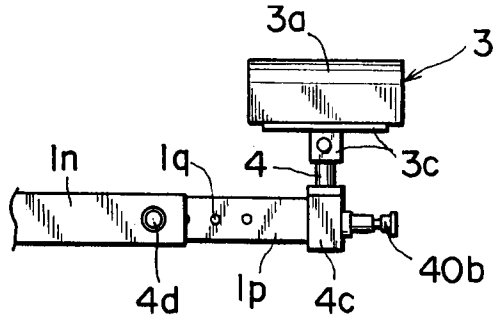

Fig. 10

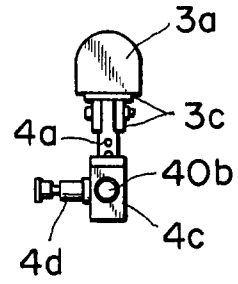

Fig. 11

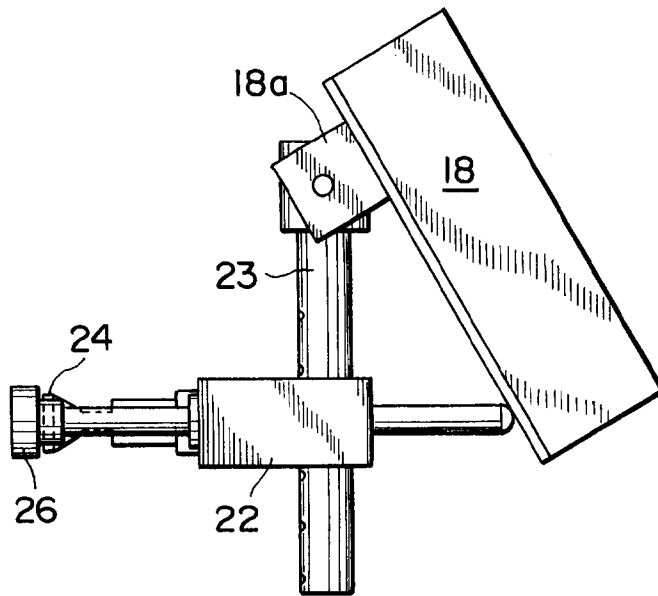

Fig. 13

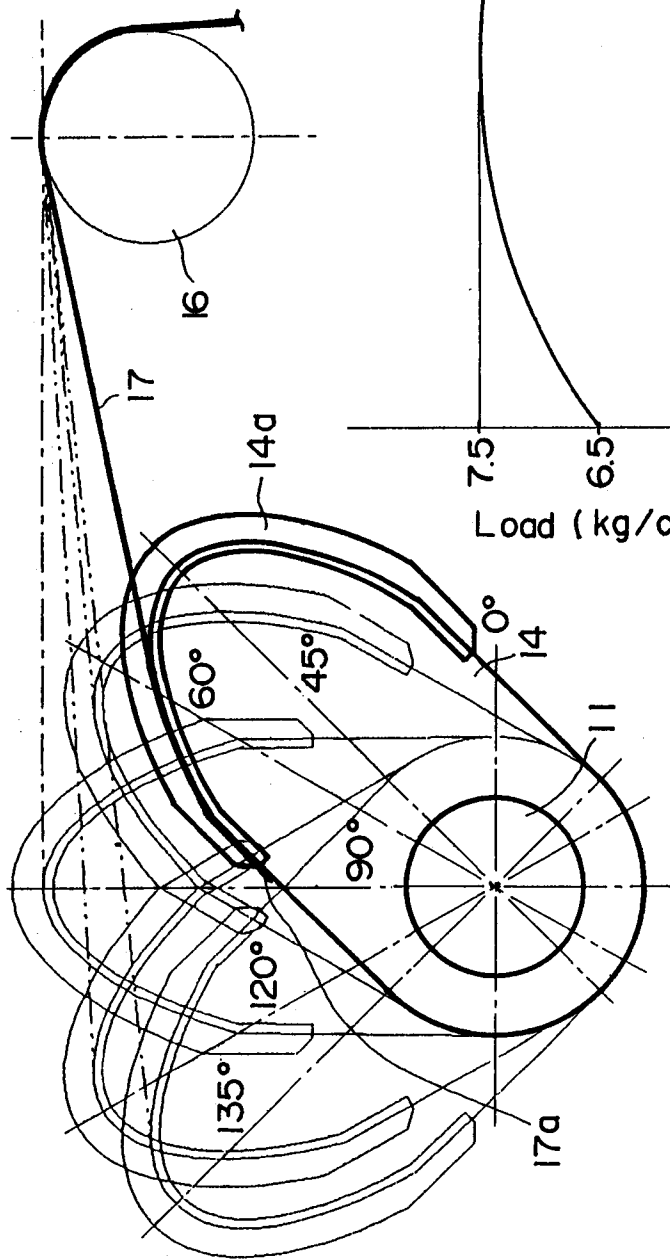
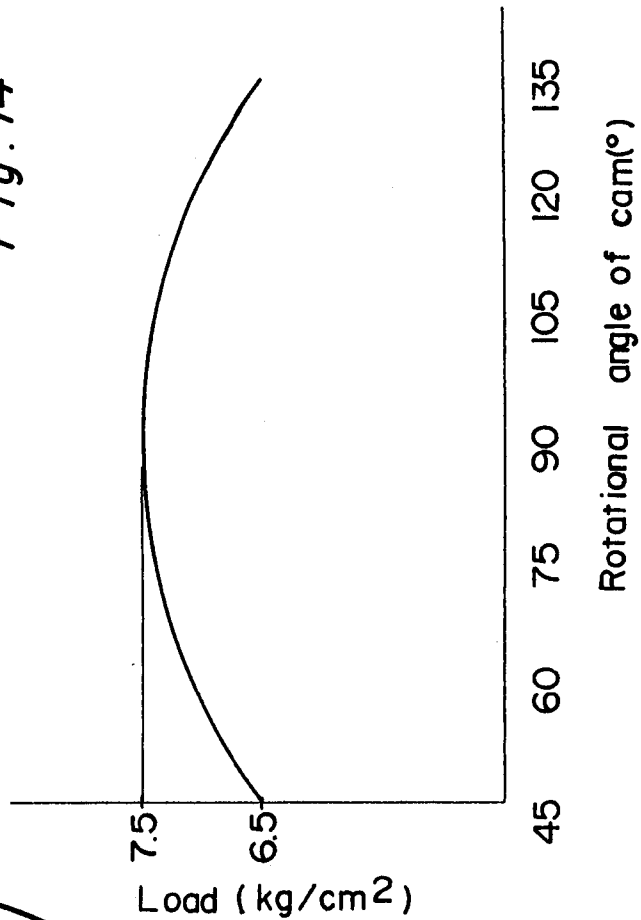
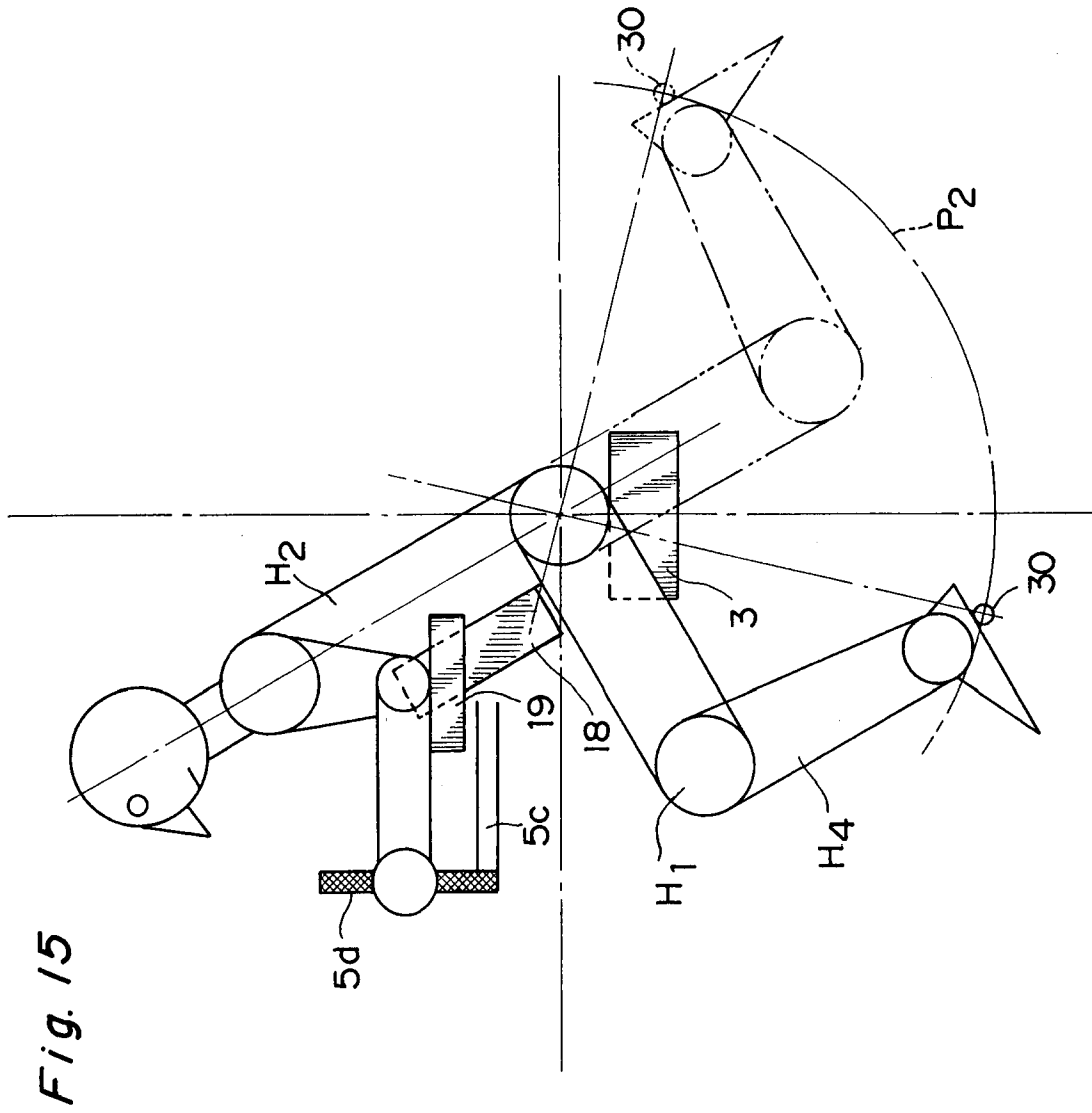

Fig. 14





INTERNATIONAL SEARCH REPORT

International application No.

PCT/JP97/00023

A. CLASSIFICATION OF SUBJECT MATTER Int. Cl ⁶ A63B23/04, A63B23/00 According to International Patent Classification (IPC) or to both national classification and IPC		
B. FIELDS SEARCHED Minimum documentation searched (classification system followed by classification symbols) Int. Cl ⁶ A63B23/04, A63B23/00 Documentation searched other than minimum documentation to the extent that such documents are included in the fields searched Jitsuyo Shinan Koho 1922 - 1997 Kokai Jitsuyo Shinan Koho 1971 - 1997 Toroku Jitsuyo Shinan Koho 1994 - 1997 Electronic data base consulted during the international search (name of data base and, where practicable, search terms used)		
C. DOCUMENTS CONSIDERED TO BE RELEVANT		
Category*	Citation of document, with indication, where appropriate, of the relevant passages	Relevant to claim No.
A	JP, 04-126165, A (Kayaba Industry Co., Ltd.), April 27, 1992 (27. 04. 92) (Family: none) Full descriptions, all drawings	1 - 27
A	JP, 47-46022, A (Martin S. Mazman), December 27, 1972 (27. 12. 72) Full descriptions, all drawings & US, 3953025, A & FR, 2131345, A & GB, 1336191, A	1 - 27
<input type="checkbox"/> Further documents are listed in the continuation of Box C.		<input type="checkbox"/> See patent family annex.
* Special categories of cited documents: "A" document defining the general state of the art which is not considered to be of particular relevance "E" earlier document but published on or after the international filing date "L" document which may throw doubts on priority claim(s) or which is cited to establish the publication date of another citation or other special reason (as specified) "O" document referring to an oral disclosure, use, exhibition or other means "P" document published prior to the international filing date but later than the priority date claimed		"T" later document published after the international filing date or priority date and not in conflict with the application but cited to understand the principle or theory underlying the invention "X" document of particular relevance; the claimed invention cannot be considered novel or cannot be considered to involve an inventive step when the document is taken alone "Y" document of particular relevance; the claimed invention cannot be considered to involve an inventive step when the document is combined with one or more other such documents, such combination being obvious to a person skilled in the art "&" document member of the same patent family
Date of the actual completion of the international search March 25, 1997 (25. 03. 97)	Date of mailing of the international search report April 1, 1997 (01. 04. 97)	
Name and mailing address of the ISA/ Japanese Patent Office Facsimile No.	Authorized officer Telephone No.	

Form PCT/ISA/210 (second sheet) (July 1992)