

(19)



Europäisches Patentamt  
European Patent Office  
Office européen des brevets



(11)

EP 0 879 765 A1

(12)

**EUROPEAN PATENT APPLICATION**

(43) Date of publication:  
**25.11.1998 Bulletin 1998/48**

(51) Int Cl.6: **B65D 1/02**

(21) Application number: **98250167.8**

(22) Date of filing: **15.05.1998**

(84) Designated Contracting States:  
**AT BE CH CY DE DK ES FI FR GB GR IE IT LI LU  
MC NL PT SE**  
Designated Extension States:  
**AL LT LV MK RO SI**

(72) Inventors:  
• **Roth, Marc W.**  
**College Park, Georgia 30349 (US)**  
• **Conrad, George**  
**Alpharetta, Georgia 3005 (US)**  
• **Dawson, Darryl J.**  
**Decatur, Georgia 30032 (US)**  
• **Henderson, John P.**  
**Kennesaw, Georgia 30152 (US)**

(30) Priority: **27.03.1998 US 49582**  
**21.05.1997 US 47342 P**

(74) Representative: **Pfenning, Meinig & Partner**  
**Kurfürstendamm 170**  
**10707 Berlin (DE)**

(71) Applicant: **BALL CORPORATION**  
**Muncie, Indiana 47305-2326 (US)**

(54) **Hot-fill blow moulded container**

(57) A blow molded container adapted to receive a hot-fill product, having a base with an upwardly raised central portion (30) including a plurality of radially extending triangular ribs (34), a generally cylindrical lower body portion including a label receiving area (38) with a series of circumferentially spaced pressure responsive panels (42), a mouth defined by a finish portion at an upper extremity adapted to receive a closure, and a substantially spherical portion (10) disposed between the finish portion and the lower body portion. The substantially spherical portion includes a surface feature pattern depicting a widely recognized object such as a sports ball, a sports helmet including a team identifying logo, a globe of the earth including an outline of major geological features, or a caricature of a personality.

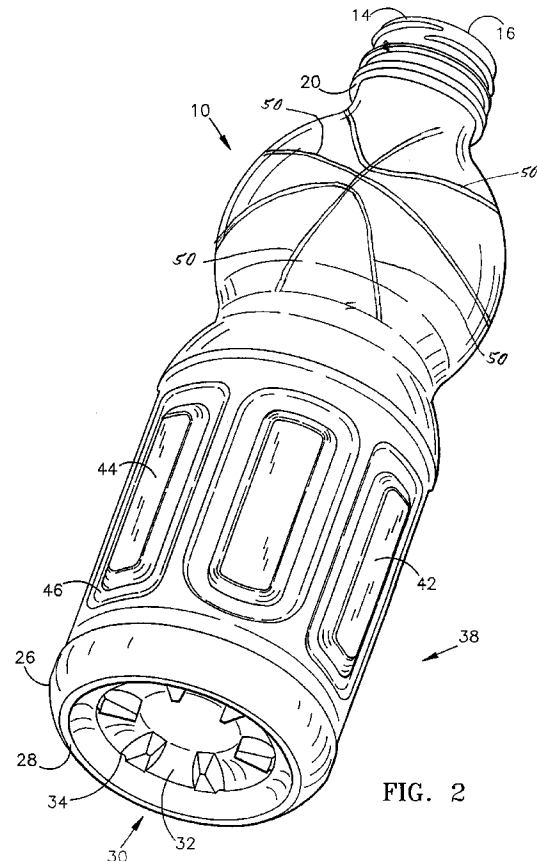

FIG. 2

EP 0 879 765 A1

## Description

### CROSS-REFERENCE TO RELATED APPLICATION

This application is based on United States Provisional Patent Application Serial No. 60/047,342, filed May 21, 1997.

### BACKGROUND OF THE INVENTION

#### 1. Field of the Invention

The present invention is directed generally to blow molded thermoplastic containers and particularly to bi-axially-oriented polyethylene terephthalate beverage bottles adapted to receive a hot-fill product at a temperature at least on the order of 80°C.

#### 2. Description of the Prior Art

Blow molded polyester containers adapted to be hot filled by foods and beverages have become well known in the industry. Such containers often include a generally cylindrical body portion which receives a separate label. The label covers a plurality of circumferentially spaced pressure responsive panels designed to compensate for variations in container volume due to the cooling of the liquid and head space gas subsequent to filling and capping of the container. Examples of containers of this general form are to be found in U.S. Patents Nos. 4,381,061, 4,542,029, 4,805,788, 4,863,046, 4,877,144, 5,054,632, 5,092,475, 5,178,289, 5,279,433, 5,337,909, 5,341,946, and 5,407,086.

In most of the containers of this general class, there is a so-called "shoulder portion" existing above the cylindrical portion and leading to a mouth defined by a finish adapted to receive a cap or closure. The shoulder portion is subject to certain variations in design which can be appreciated by reviewing the aforementioned patents as well as other patents depicting containers of this general class. Nevertheless, little attempt has been made to utilize the shoulder portion to enhance the marketability of the product contained within the container *albeit* from time-to-time the shoulder portion has included a relief molding of a trademark of material contained within the container, i.e., GATORADE®.

Accordingly, it is an object of the present invention to provide containers having enhanced market acceptance by utilizing the shoulder portion of the container to enhance customer affinity.

### SUMMARY OF THE INVENTION

In accordance with the present invention, a blow molded container of thermoplastic material includes a base supporting a generally cylindrical lower body portion including a label receiving area which can include a series of circumferentially spaced pressure respon-

sive panels to accommodate for hot filling of the container. A mouth defined by a finish portion is provided at an upper end of the container and is adapted to receive a closure. Between the finish portion and the generally cylindrical lower body portion, there is provided a substantially spherical portion which includes thereon a surface feature pattern depicting a widely recognized object likely to enhance customer affinity to the product. Examples of such objects include a sports ball such as a basketball, baseball, soccer ball, volley ball, etc. A further example includes a sports helmet including a team identifying logo, a globe of the earth including an outline of major geological and/or geo-political features. Another example is a caricature of a personality such as a living sports person, a movie or record star, a comic character or the like.

In the preferred embodiment, the substantially spherical portion having the surface feature pattern would be separated from the cylindrical portion by a waist portion. The diameter of the generally spherical portion would approximate the diameter of the generally cylindrical lower body portion. The generally spherical portion of the container would generally contribute less than half of the volume of the container. Further, the base would preferably comprise an upwardly raised central portion defining an outer continuous seating ring. Details of the structure of an example of a preferred embodiment is to be shown in the accompanying figures which depict the best mode of carrying out the invention as presently perceived.

### BRIEF DESCRIPTION OF THE DRAWINGS

FIG. 1 is a side elevation view of a container in accordance with the present invention.

FIG. 2 is a perspective view of the bottom and side of the container shown in FIG. 1.

FIG. 3 is a side elevation view of a container in accordance with a second embodiment of the present invention.

FIG. 4 is a side elevation view of a container in accordance with a third embodiment of the present invention.

FIG. 5 is a side elevation view of a container in accordance with a fourth embodiment of the present invention.

FIG. 6 is a side elevation view of an alternative representation of the embodiment depicted in FIG. 1.

### DESCRIPTION OF THE PREFERRED EMBODIMENTS

A container 10 in accordance with the present invention is illustrated in the accompanying drawings, FIGS. 1 and 2. Container 10 is generally symmetric about a vertical axis "Y" passing through the center of mouth 12 which provides access to the interior of container 10. Mouth 12 is defined by an upper perimeter of

a finish portion 14 which includes a threaded portion 16 adapted to receive a closure, not shown. Finish portion 14 also includes a pilfer indicating engagement ring 18 intended to engage a lower skirt of the closure and to cooperate therewith to irreversibly indicate opening of the closure. A support ring 20 is provided at the lower end of finish portion 14 to facilitate manufacture and handling of container 10. Below support ring 20 is a neck portion 22 which flares outwardly to merge with substantially spherical portion 24, discussed below.

At its lower end, container 10 includes base 26 having at its lower-most extremity a continuous seating ring 28 which defines an outer perimeter of an upwardly raised central portion 30 shown in FIG. 2. The upwardly raised central portion 30 includes an apex 32 immediately adjacent to a lower end of the vertical axis "Y" which is joined to seating ring 28 by a plurality of radially extending triangular ribs 34.

An upper edge of base 26 defines a lower margin 36 of a substantially cylindrical lower portion 38 having an upper margin 40. The lower and upper margins 36 and 40 define the boundaries of a label portion adapted to receive a film or paper label having product identifying indicia thereon (not shown). The label portion includes a series of circumferentially spaced pressure responsive panels 42. Pressure responsive panels 42 are subject to some variation in design as shown in the prior art, but generally include a central land 44 surrounded by a channel 46 which allows central land 44 to move radially inward and outward in response to changes in pressure in the container.

Above the upper margin 40 of the label panel is a waist portion 48 which smoothly integrates with substantially spherical portion 24. Substantially spherical portion 24 includes a surface feature pattern depicting a widely recognized object intended to enhance the customer affinity for the container and the product contained therein. In FIGS. 1 and 2, the surface feature pattern comprises a plurality of grooves or ridges 50 which, taken together, depict the widely recognized seam structure of a basketball. It will be appreciated that the seam structure of other sports balls could be substituted for the illustrated seams 50 to depict a baseball, a soccer ball as shown in FIG. 6, a tennis ball, a volley ball, etc. The surface feature pattern could also depict, as shown in FIG. 3, a sports helmet and face mask which together would be substantially spherical and include a team identifying logo on a portion thereof. The surface feature pattern could also depict a globe of the earth, as depicted in FIG. 4, including an outline of major geological features, major geo-political features, or other elements of interest to the purchaser of the container. The surface feature pattern on the substantially spherical portion could also depict a caricature of a personality, as shown in FIG. 5, such as a movie star, a cartoon character, a famous person of history, or the like. In each instance, the depiction is intended to enhance the general public's affinity to the container thereby enhancing brand and/or

product loyalty.

It will be appreciated by those skilled in the art that the grooves or ridges 50 depicted in FIGS 1-2 can be formed in the container at the time of blow molding by providing the reverse feature in the blow mold in which the container 10 is formed. Line 52 shown in FIG. 1 is a mold parting line separating a left and right side of the blow mold. In the finished product, of course, it is desirable that the mold parting line be minimized and/or eliminated so it does not detract from the overall appearance of the container.

Although the invention has been described in detail with reference to the illustrated preferred embodiment, variations and modifications exist within the scope and spirit of the invention as described and as defined in the following claims.

### Claims

1. A blow molded container of thermoplastic material comprising a base, a generally cylindrical lower body portion including a label receiving area, a mouth defined by a finish portion at an upper extremity adapted to receive a closure, and a substantially spherical portion intermediate of the finish portion and the lower body portion, the substantially spherical portion including thereon a surface feature pattern depicting a widely recognized object.
2. The blow molded container of claim 1 wherein the surface feature pattern depicts a seam structure of a sports ball.
3. The blow molded container of claim 1 wherein the surface feature pattern depicts a sports helmet including a team identifying logo.
4. The blow molded container of claim 1 wherein the surface feature pattern depicts a globe of the earth including an outline of major geological features.
5. The blow molded container of claim 1 wherein the surface feature pattern depicts a caricature of a personality.
6. The blow molded container of any of claims 1 - 5 further comprising a waist portion coupling the generally spherical portion to the generally cylindrical lower body portion.
7. The blow molded container of any of claims 1 - 5 wherein a diameter of the generally spherical portion is approximately equal to a diameter of the generally cylindrical lower body portion.
8. The blow molded container of any of claims 1 - 5 wherein the label receiving area of the generally cy-

lindrical lower body portion comprises a series of circumferentially spaced pressure responsive panels formed therein.

9. The blow molded container of any of claims 1 - 5 wherein the container is a biaxially-oriented polyethylene terephthalate beverage bottle adapted to receive a hot-fill product at a temperature at least on the order of 80°C and a positive internal pressure on the order of 4 psi.
10. The blow molded container of any of claims 1 - 5 wherein the base comprises an upwardly raised central portion including a plurality of radially extending triangular ribs.
11. A biaxially-oriented polyethylene terephthalate beverage bottle adapted to receive a hot-fill product at a temperature at least on the order of 80°C and a positive internal pressure on the order of 4 psi comprising a base having an upwardly raised central portion including a plurality of radially extending triangular ribs, a generally cylindrical lower body portion including a label receiving area having a series of circumferentially spaced pressure responsive panels formed therein, a mouth defined by a finish portion at an upper extremity adapted to receive a closure, and a substantially spherical portion intermediate of the finish portion and the lower body portion, the substantially spherical portion including thereon a surface feature pattern depicting a widely recognized object selected from the group consisting of a sports ball, a sports helmet including a team identifying logo, a globe of the earth including an outline of major geological features, and a caricature of a personality.

5

10

15

20

25

30

35

40

45

50

55

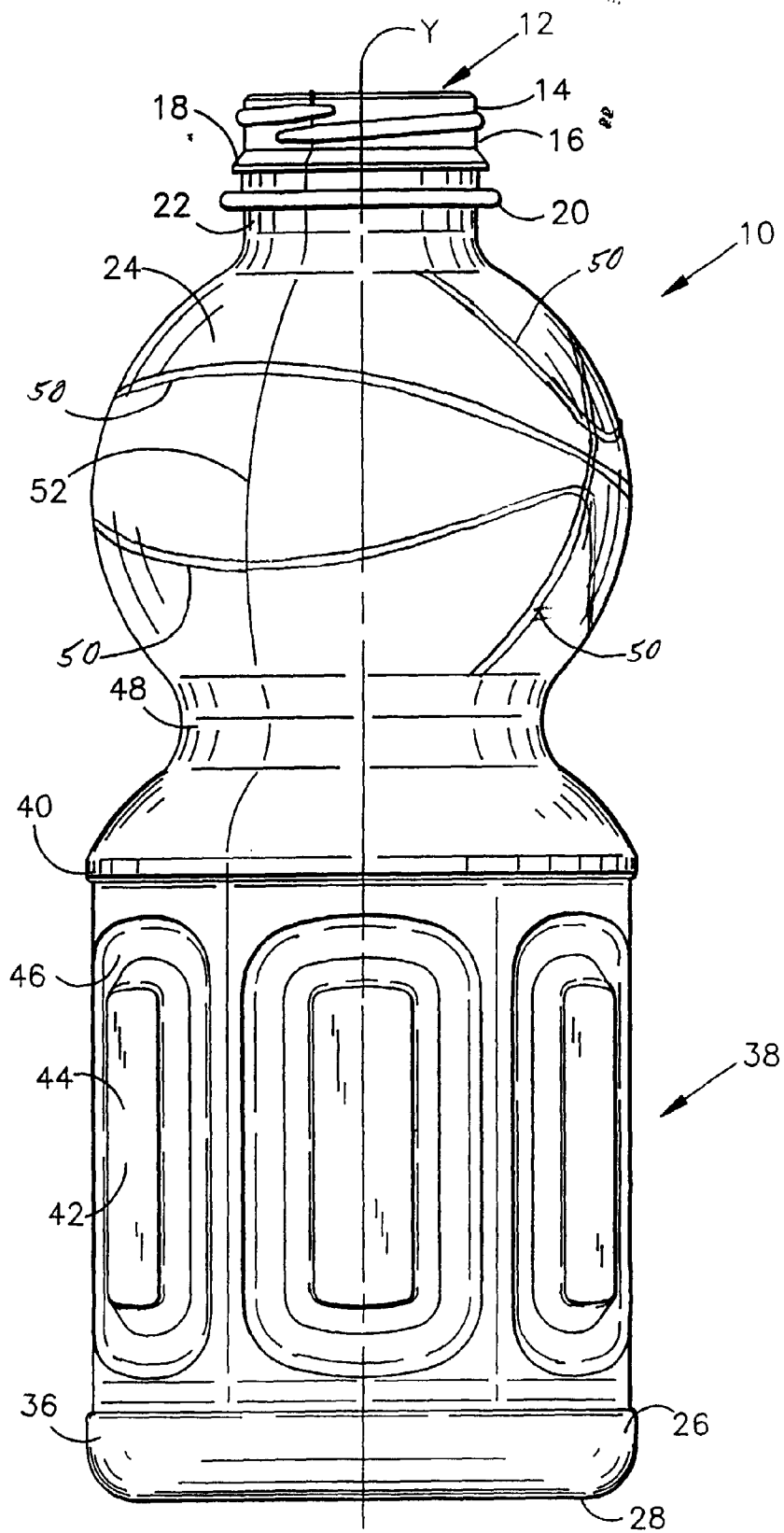

FIG. 1

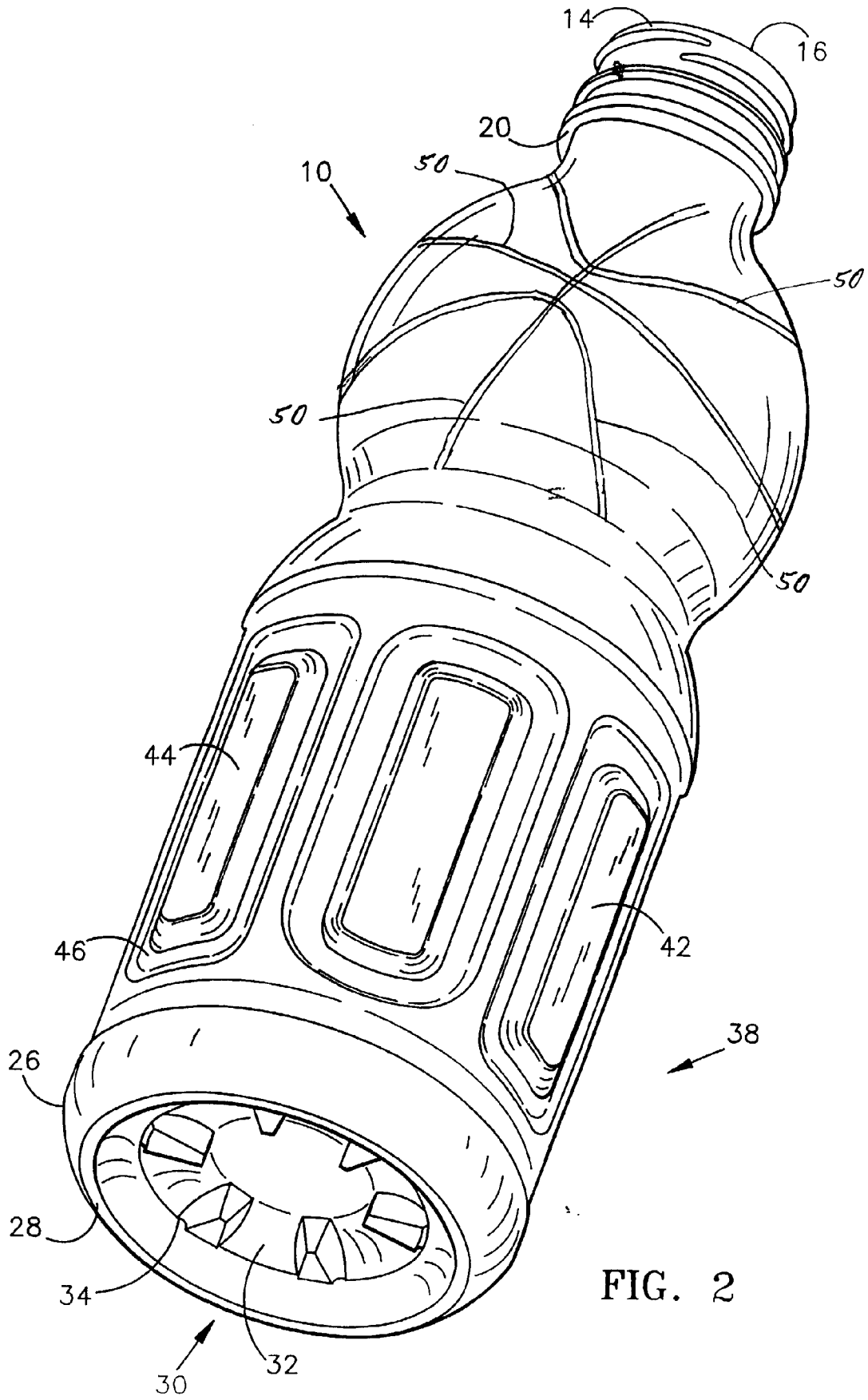

FIG. 2

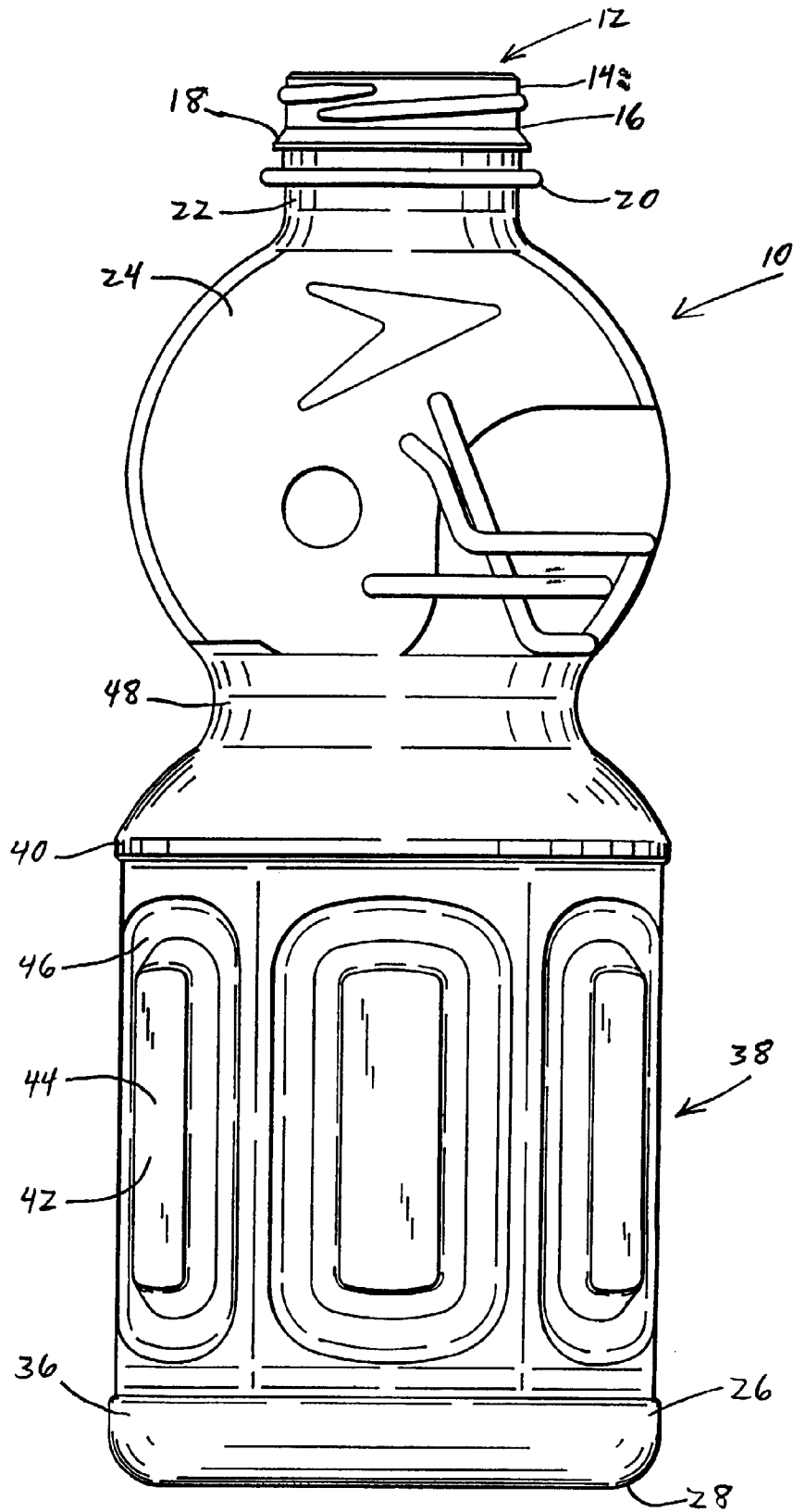

FIG. 3

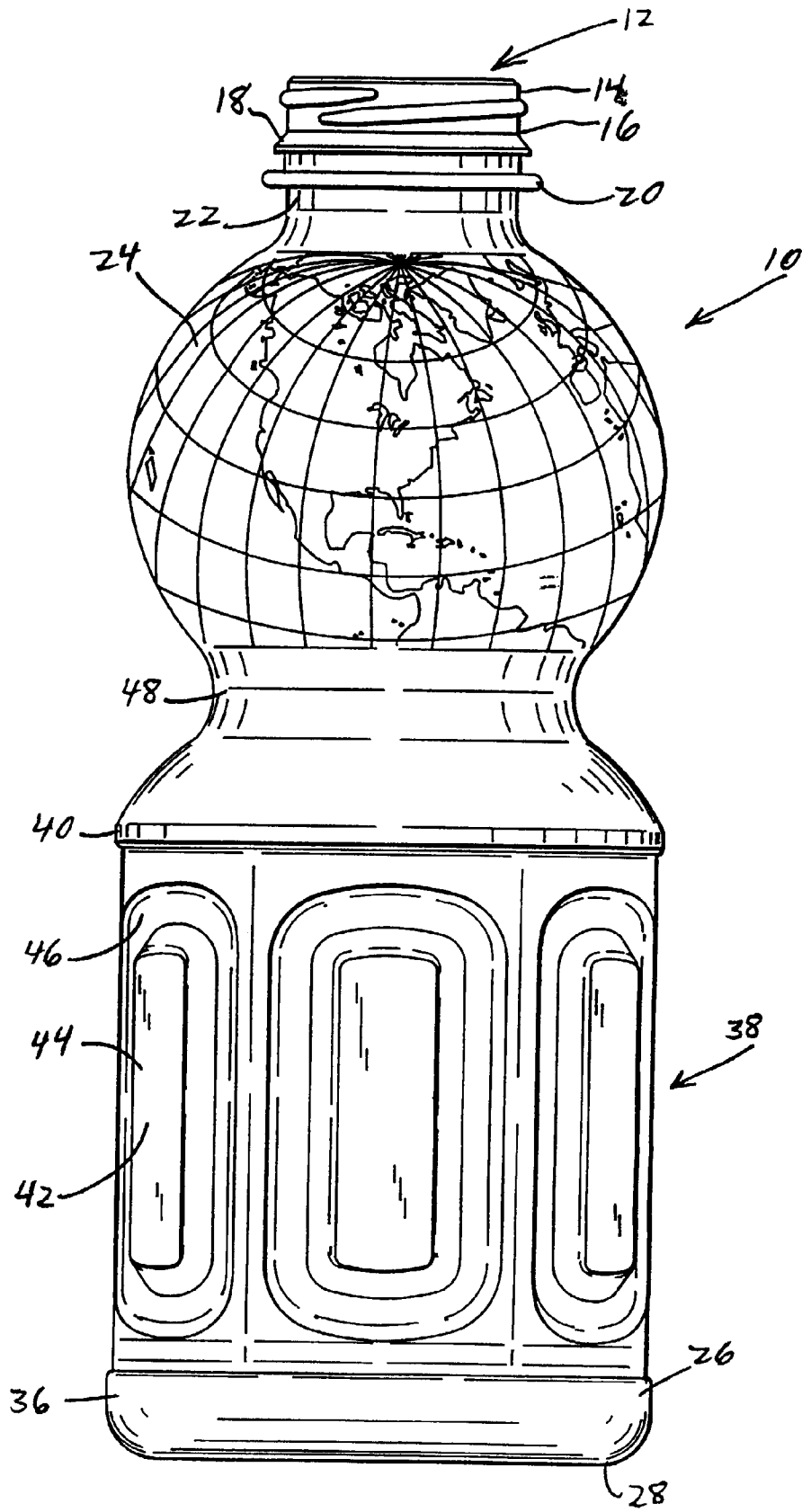

FIG. 4

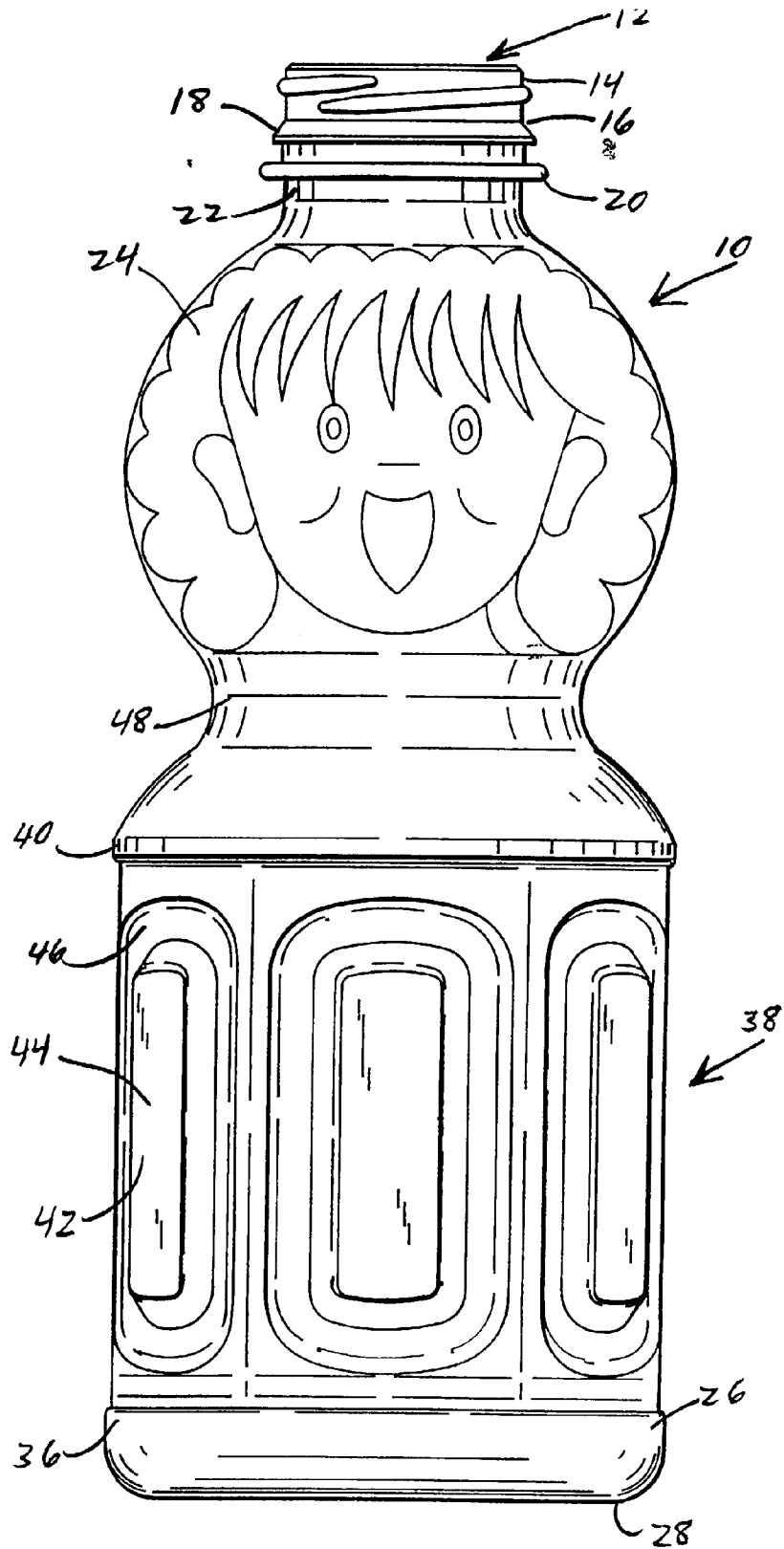

FIG. 5

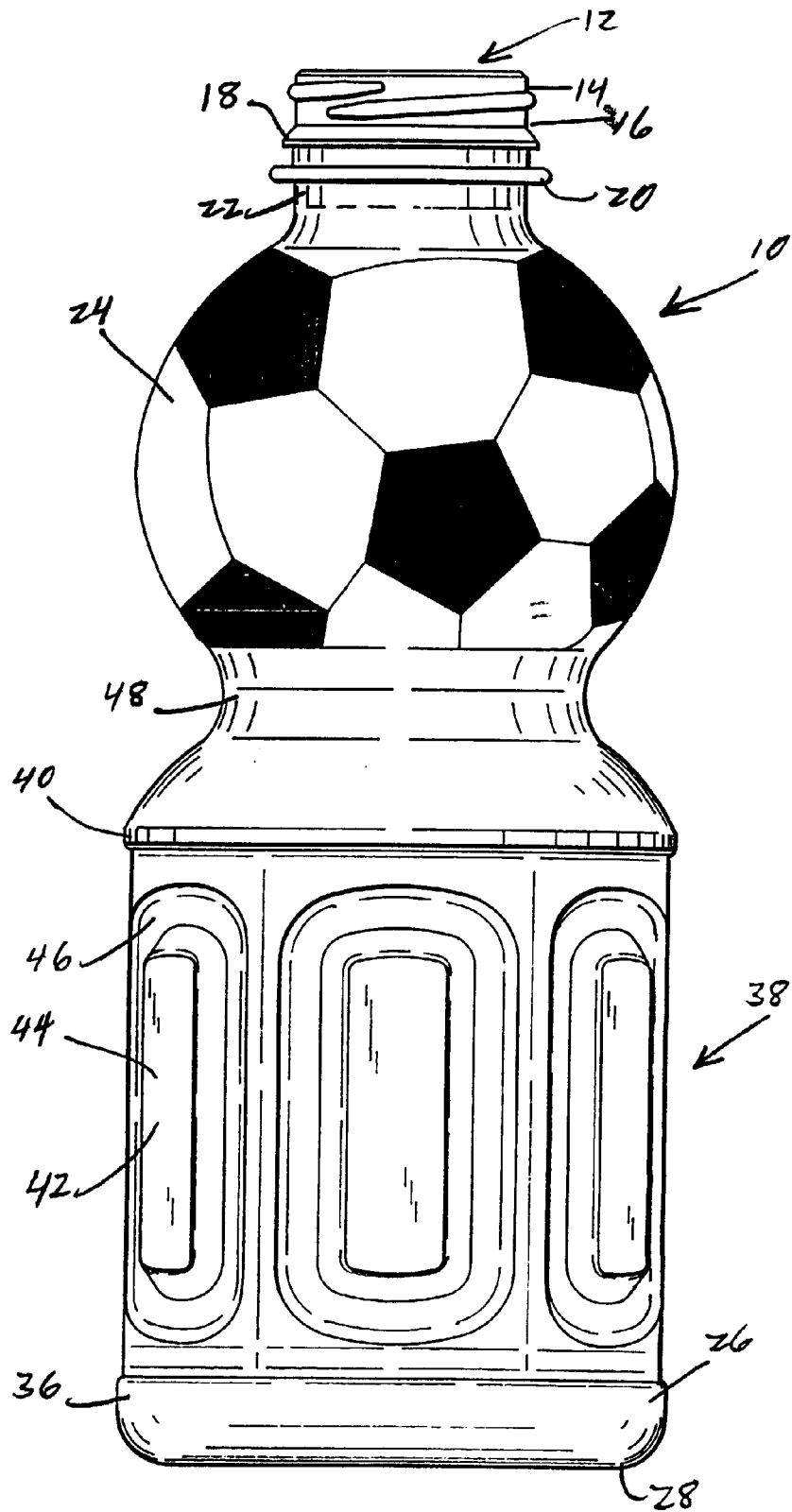

FIG. 6



European Patent  
Office

EUROPEAN SEARCH REPORT

Application Number  
EP 98 25 0167

DOCUMENTS CONSIDERED TO BE RELEVANT			
Category	Citation of document with indication, where appropriate, of relevant passages	Relevant to claim	CLASSIFICATION OF THE APPLICATION (Int.Cl.6)
X Y	WO 97 14617 A (AMCOR) 24 April 1997 * page 5, line 22 - page 12, line 7; figures 3,4 *	1-9 10,11	B65D1/02
A	FR 2 449 601 A (HAYLE) 19 September 1980 * page 2, line 1 - line 8; figure 1 *	1,11	
Y	US 4 318 882 A (PURUSHOTTAM) 9 March 1982 * column 3, line 3 - column 4, line 19; claim 1 *	10,11	
A	US 5 598 941 A (SEMERSKY) 4 February 1997 * column 1, line 44 - line 58; figures *	9-11	
The present search report has been drawn up for all claims			TECHNICAL FIELDS SEARCHED (Int.Cl.6)
			B65D
Place of search	Date of completion of the search	Examiner	
THE HAGUE	3 August 1998	Newell, P	
CATEGORY OF CITED DOCUMENTS		T : theory or principle underlying the invention E : earlier patent document, but published on, or after the filing date D : document cited in the application L : document cited for other reasons & : member of the same patent family, corresponding document	
X : particularly relevant if taken alone Y : particularly relevant if combined with another document of the same category A : technological background O : non-written disclosure P : intermediate document			

EPO FORM 1503 03 02 (P04C01)