

(19)



Europäisches Patentamt
European Patent Office
Office européen des brevets



(11)

EP 0 898 253 A2

(12)

EUROPEAN PATENT APPLICATION

(43) Date of publication:
24.02.1999 Bulletin 1999/08

(51) Int Cl.6: **G07F 17/32**

(21) Application number: **98306437.9**

(22) Date of filing: **12.08.1998**

(84) Designated Contracting States:
**AT BE CH CY DE DK ES FI FR GB GR IE IT LI LU
MC NL PT SE**
Designated Extension States:
AL LT LV MK RO SI

(72) Inventor: **Randall, Dov Liam**
Sunnybank, Bury, Lancashire (GB)

(74) Representative: **Quest, Barry et al**
Wilson, Gunn, M'Caw,
41-51 Royal Exchange,
Cross Street
Manchester M2 7BD (GB)

(30) Priority: **13.08.1997 GB 9717053**

(71) Applicant: **BARCREST LIMITED**
Ashton-under-Lyne Lancashire OL7 0QQ (GB)

(54) **Entertainment machines**

(57) A coin-operated entertainment machine of the "fruit" or "poker" variety which has axially aligned reels (9) with symbols at regular spaced intervals around their periphery. A button (6a) gives the player the option of selecting which line(s) of symbols are taken into account by selecting a game win mode. In addition, a button (6b)

gives the player the option of selecting independently of the game win mode, a stake multiplication factor from the range of multiplication values. The entertainment machine also has a visual display which indicates to the player which game win mode (17) has been selected, which stake multiplication (18) has been selected, a current win likelihood and a current payout percentage (21).

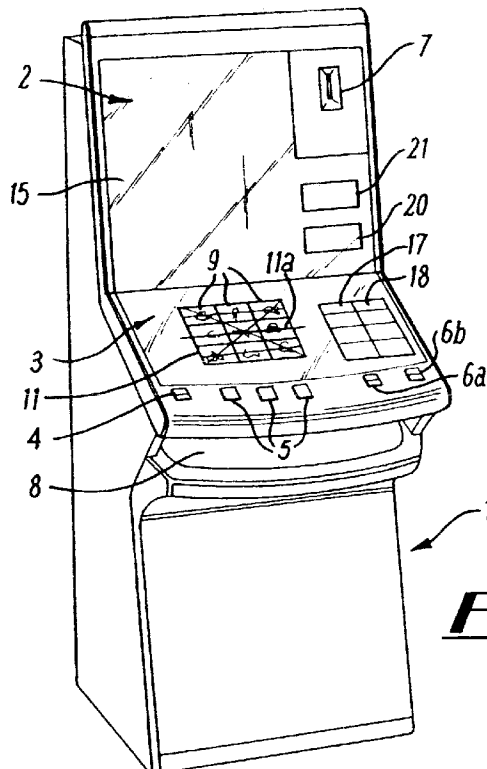

Fig. 1

EP 0 898 253 A2

Description

[0001] This invention relates to a coin-operated entertainment machine, particularly an amusement or gaming machine of the 'fruit' or 'poker' kind, which is operable by a player to play a game in which a combination of symbols is selected and displayed at a win zone. As used herein, the term coin-operated is intended to cover operation by coins, tokens, bank notes, credit cards, cash cards, pre-paid cards or any other form of monetary value.

[0002] A known 'fruit' or 'poker' machine has three symbol-bearing reels (or video simulations thereof) rotatable about a common horizontal axis behind a window. When stopped, each reel displays three symbols through the window centred on a horizontal win line. A win is awarded in the event that the combination of symbols on the win line is a predetermined winning combination.

[0003] It is also known for a win to be awarded if the symbol combination on one or more other lines of the displayed 3x3 matrix of symbols is a predetermined winning combination. With a 3x3 matrix there are 5 possible straight lines (three horizontal and two diagonal) which include all three reels, and it is known to use some or all of these as win lines. It is also known to award wins in relation to any combination of symbols selected from the three reels in any positions within the 3x3 matrix which gives 27 winning possibilities.

[0004] When a win is awarded, a value may be attributed to this based on the kind of win and a multiplication factor applied to the stake made by the player at the start of the game.

[0005] The likelihood of winning is determined by the control system of the machine for a particular stake multiplication factor in relation to a desired award payout percentage. Thus, if the stake multiplication factor is high and there is a relatively high number of ways of winning (e.g. the above mentioned 27 combinations) then there must be a relatively high weighting against the attainment of a win. A high win award is made available to the player but the likelihood of attaining this is low.

[0006] It is known to give the player the opportunity of influencing the available magnitude and likelihood of award with the aim of enhancing entertainment value, and to enable the player to select the risk which he wishes to take. However, hitherto such opportunities have been of limited value and, in particular, have involved the use of a single player-operable selector control.

[0007] An object of the present invention is to provide enhanced opportunities for player intervention or participation with regard to win opportunities and stake multiplication.

[0008] According to one aspect of the present invention therefore there is provided a coin-operated entertainment machine which is operable by a player to play a game in which a combination of symbols is selected

and displayed at a win zone, and a win indication is given in the event that an outcome of said game is of a predetermined winning nature, said win indication including an evaluation of a win award determined in relation to a stake made for the said game, characterised by the provision of player controls operable to select independently, from respective ranges thereof, a stake enhancement factor and a game win mode.

[0009] With this arrangement, the player is given the opportunity of selecting independently the game win mode used for win evaluation purposes and also the stake enhancement factor. The player therefore has the possibility of choosing a desired level of risk on the basis of both win mode and stake enhancement whereby the player is given an increased opportunity of intervention and participation in the manner of operation of the machine.

[0010] Most preferably the machine is of the kind with which symbols are selected and displayed in a matrix, in a plurality of rows and columns whereby the said selection of game win mode may constitute or include selection of the ways in which symbol combinations are assessed for win evaluation purposes within the matrix. In particular, the player can be given the opportunity of determining which lines of symbols or which other arrangements are taken into account.

[0011] There may be a 3x3 matrix of displayed symbols whereby up to 5 lines (three across and two diagonal) may be used as win lines, such as may be the case with a conventional arrangement of three side-by-side symbol bearing reels rotatable behind a window (or video simulations thereof).

[0012] Also, as mentioned above, the player may also opt to take into account all combinations of three symbols taken one from each column in the 3x3 matrix giving 27 ways of winning.

[0013] Other arrangements, e.g. involving a 4x3 matrix, such as is the case with a conventional 4 reel machine, may be used.

[0014] In this context there may be a said player control which is operable by the player to select, at the will of the player, the number of lines to be used as win lines, say 1, 3 or 5 in the case of the 3x3 matrix, and/or other ways of attaining winning combinations such as the 27 ways mentioned above.

[0015] Alternatively or additionally the said selection of game win mode may also comprise selection of a win mode determined by the presence of special symbols (such as symbols giving entry to a supplementary 'feature' game or other special awards).

[0016] The player may also be given the opportunity of selecting availability of award opportunities not related to displayed symbol combinations, such as losing game awards.

[0017] With regard to the stake enhancement factor, there may be a said player control which is operable by the player to select, at the will of the player, a numerical multiplier of say x1, x2, x3, x5, x10 and this may be ap-

plied to all wins, or only to selected wins.

[0018] The said player controls may consist of physically separate buttons or switches, one for the win mode, and the other for the stake enhancer. Alternatively there may be a single control which is operable in independent states respectively relating to the win mode and the stake enhancer.

[0019] The player controls may be made wholly available at the start of every game. Alternatively different availability may be utilised including for example availability at a different point in the game, availability in only some games as selected on a random or predetermined basis, partial availability during a game whereby for example on some occasions only one of the win mode and stake enhancer may be available for selection.

[0020] The selection made may be applied to all or only a part of the available stake or player credit.

[0021] Most preferably the machine is provided with an appropriate visual display, for example in the form of one or more ladder displays, indicating, as for example, by back illumination of successive display areas, the selection made by the player from the range of available such selections.

[0022] In accordance with conventional practice, as mentioned above, the likelihood of attaining a winning combination is set in relation to a desired overall award level for the machine. In particular, where a win results in, or makes available to the player, a payout, the machine may be set for a desired payout percentage i.e. the percentage of credit put in by players which is returned as win payouts.

[0023] The arrangement is preferably such that a control system of the machine determines win likelihood in relation to the player-selected win mode and the player-selected stake enhancement, and an indication of the likelihood may be given to the player with an appropriate visual display.

[0024] In this way, the player can chose the risk which he wishes to take in pursuance of higher awards, and this is selected accordingly by the player by appropriate selection of the win mode and stake enhancement.

[0025] Indication of likelihood can be given by numerical indications alongside displayed win mode and stake enhancement selections. Alternatively or additionally, there may be a display which shows a resultant computed indication. Conveniently, the likelihood may be indicated in terms of variation in stake value.

[0026] In correspondence with pursuance of higher risks, as mentioned, the win likelihood may decrease. The overall award level, e.g. payout percentage, may be maintained irrespective of selection of win mode and stake enhancement.

[0027] Alternatively and preferably however the award level may be varied and, in particular, win likelihood may be decreased, and the payout percentage or other award level may be increased.

[0028] A visual display, for example in the form of a numerical display may be provided to indicate the cur-

rent award level.

[0029] In accordance with conventional practice award level, such as percentage payout is maintained by influencing generation of winning combinations and/or game features which increase likelihood of winning.

[0030] The invention will now be described further by way of example only an with reference to the accompanying drawings in which:-

- 5
10
15
- Fig. 1 is a diagrammatic representation of one form of a machine according to the invention;
Fig. 2 is a diagrammatic view of part of a display of the machine; and
Fig. 3 is a block circuit diagram of the machine.

[0031] Referring to the drawings, these show a fruit machine having a floor-standing box shaped housing 1 having a front wall which includes upper and lower glass panels 2, 3, a number of operating buttons 4, 5, 6a, 6b, a coin slot 7 and a payout opening 8.

[0032] Within the housing 1 there are three axially aligned reels 9 having say 20 symbols at regularly spaced positions around their peripheries. The reels 9 are axially rotatable and are drivably connected to respective stepper motors 10. The reels 9 are arranged behind a window 11 defined by a printed region of the lower glass panel 3. Each reel 9 can be arrested by the respective stepper motor 10 in any of 20 stopping positions in which one symbol is in precise registration with a horizontal win line 11a in the centre of the window 11 and two further symbols are visible above and below the win line. The three reels therefore display a matrix of 3x3 symbols in three columns (i.e. the three reels) and three rows (across the three reels).

[0033] The stepper motors 10 are connected to a microprocessor-based control unit 12. This unit is also connected to a coin-mechanism 13, a payout mechanism 14 and the buttons 4, 5, 6.

[0034] In use, the player inserts coins into the coin mechanism 13 through the slot 7 sufficient to generate credit for one or more games, and the machine is actuated so that a game can now be played. The game commences after a start button 4 has been pressed and the reels 9 spin and then come to rest at random (or pseudo random) so as to select a combination of symbols displayed on the win line. The displayed symbol combination is assessed by the control unit 12 and a win indication is given in the event that the combination is of a predetermined winning nature, as discussed in more detail hereinafter.

[0035] The control buttons 5 can be used to perform 'hold' or 'nudge' functions, when made available to the player, so that the player can seek to influence the outcome of a game, in conventional manner.

[0036] The buttons 6a, 6b are used to influence win possibilities as described hereinafter.

[0037] The upper panel 2 is a transparent glass panel having a display region 15, which can be back-illuminat-

ed with a bank of lamps 16, and which provides a supplementary game feature. In conventional manner, play can transfer from the reels 9 to the display region 15 for example when a transfer symbol appears in the window 11.

[0038] Alongside the window 11 on the lower glass panel there are two ladder displays 17, 18 respectively above the two buttons 6a, 6b. Each ladder display comprises areas which can be back illuminated with lamps 19 connected to the control system 12.

[0039] There are also two adjacent digital LED displays 20, 21 connected to the control system.

[0040] At the start of a game, a stake value for the game is shown on the LED display 20. This may be say 20p.

[0041] The player has the option of increasing this by pressing the button 6b. Each time the button is pressed, the next area of the ladder 18 is illuminated and a respective stake multiplication factor is selected (x1, x2, x3, x5 or x10). The numerical value on the display 20 is appropriately changed. Thus, if x2 is selected, the display will change from 20p to 40p.

[0042] The player also has the opportunity of selecting the win mode using the button 6a. Each time the button 6a is pressed the next area of the ladder 17 is illuminated. The areas represent selection respectively of 1, 3, 5 pay lines, 27 win ways, and 27 win ways plus losing game awards and feature entry.

[0043] The 1, 3, 5 pay line options relate to the 5 possible win lines on the 3x3 matrix (three horizontal and two diagonal) utilising all three reels. The player can select 1 line, which means that only the symbol combination on the win line 11a is assessed. The player can also select 3 or 5 pay lines whereby combinations on all of these lines are assessed. If the 27 win ways option is selected, all 27 symbol combinations are assessed; and, with the highest selection, it is also possible to obtain other wins such as transfer to the feature game and losing game awards.

[0044] If the player selects the lowest win mode i.e. the one win line 11a, the LED display shows the stake value as mentioned above e.g. 20p multiplied by the selected multiplication factor.

[0045] If the player selects one of the higher win modes this gives more ways of winning and it is therefore necessary to reduce the effective stake value so that payout percentage will remain within predetermined acceptable limits having regard to the increased likelihood of winning due to the selection of the higher win mode. The effective stake value is shown on the LED display 20.

[0046] The effective stake value is computed as a function of a predetermined weighting value for the selected stake multiplication factor multiplied by a predetermined weighting value for the selected game mode. Suitable values are shown in Fig. 2 alongside the ladder areas by way of example, although in practice these would not be displayed to the player.

[0047] The other LED display 21 shows a numerical value for the current payout percentage which may be 80-90% or higher. This percentage is normally set at a fixed value. However, it may be increased, by way of encouragement to the player with increase in stake value.

[0048] With the above arrangement the player is given an increase opportunity to participate in the operation of the machine and, in particular, by operating the two buttons 6a, 6b, the player can chose the level of reward, and consequently the level of risk, which he requires.

[0049] It is of course to be understood that the invention is not intended to be restricted to the details of the above embodiment which are described by way of example only.

Claims

1. A coin-operated entertainment machine which is operable by a player to play a game in which a combination of symbols is selected and displayed at a win zone, and a win indication is given in the event that an outcome of said game is of a predetermined winning nature, said win indication including an evaluation of a win award in relation to a stake made for the said game, characterised by the provision of player controls (6b, 6a) operable to select independently, from respective ranges thereof, a stake enhancement factor and a game win mode.
2. An entertainment machine according to claim 1, wherein the symbols are selected and displayed in a matrix which comprises a plurality of rows and columns whereby the said selection of a game win mode includes a selection of ways in which symbol combinations are assessed for win evaluation purposes within the said matrix.
3. An entertainment machine according to claim 2, wherein the player is given the opportunity of determining which line(s) or other arrangements of said symbols are taken into account.
4. An entertainment machine according to claim 2 or claim 3, wherein the matrix of displayed symbols has lines across and diagonal lines which we used as win lines.
5. An entertainment machine according to claim 4, wherein the player has the option of selecting all combinations of three symbols taken one from each column in the matrix.
6. An entertainment machine according to any preceding claim, wherein the said selection of game win mode comprises the selection of a game win mode determined by the presence of special sym-

bols.

7. An entertainment machine according to any preceding claim, wherein the player is given the opportunity of selecting availability of a game win mode not related to displayed symbol combinations, including losing game awards. 5
8. An entertainment machine according to claim 1, wherein the player control of the stake enhancement factor (6b) is operable to select a numerical multiplier. 10
9. An entertainment machine according to claim 8, wherein the numerical multiplier is selectable from a plurality of multiplication values. 15
10. An entertainment machine according to any claim 8 or 9, wherein the numerical multiplier is applied to all wins. 20
11. An entertainment machine according to claim 8 or 9, wherein the numerical multiplier is applied only to selected wins. 25
12. An entertainment machine according to any preceding claim, wherein the said player controls (6a, 6b) consist of physically separate controls whereby one player control operates the game win mode (6a) and another player control operates the stake enhancement factor (6b). 30
13. An entertainment machine according to any one of claims 1 to 11, wherein the said player controls (6a, 6b) is a single control which is operable in independent states respectively relating to the game win mode and stake enhancement factor. 35
14. An entertainment machine according to any one of claims 1 to 13, wherein the player controls (6a, 6b) are only partially available during a game, whereby only one of the game win mode and stake enhancement factor is available for selection. 40
15. An entertainment machine according to any preceding claim, wherein the selection of game win mode and stake enhancement factor is applied to all of the available stake or credit. 45
16. An entertainment machine according to any one of claims 1 to 14, wherein the selection of game win mode and stake enhancement factor is applied to only a part of the available stake or credit. 50
17. An entertainment machine according to any preceding claim, wherein the machine is provided with an appropriate visual display which indicates the selection of game win mode (17) and stake enhancement factor (18) made by the player from the range of available said selections. 55
18. An entertainment machine according to any preceding claim, wherein the machine has a control system which determines a win likelihood in relation to the player selected game win mode and the player selected stake enhancement factor, and an indication of the likelihood is given to the player with an appropriate visual display.
19. An entertainment machine according to claim 18, wherein an indication of win likelihood is given by numerical indications alongside displayed game win mode (17) and stake enhancement factor (18) selections.
20. An entertainment machine according to claim 19, wherein the indication of win likelihood comprises a display showing a resultant computed indication of the win likelihood.
21. An entertainment machine according to claim 19, wherein the indication of win likelihood is illustrated to the player in terms of variation in stake value (20).
22. An entertainment machine according to any one of claims 1 to 21 wherein payout percentage and win likelihood is varied.
23. An entertainment machine according to any one of claims 1 to 22 wherein current payout percentage is provided in the form of a numerical display.

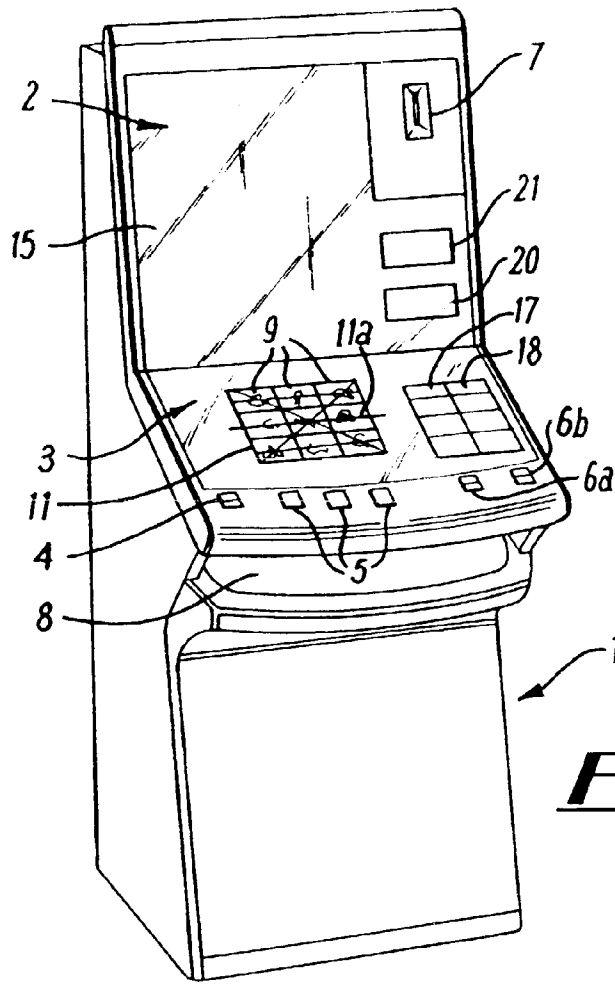

FIG. 1

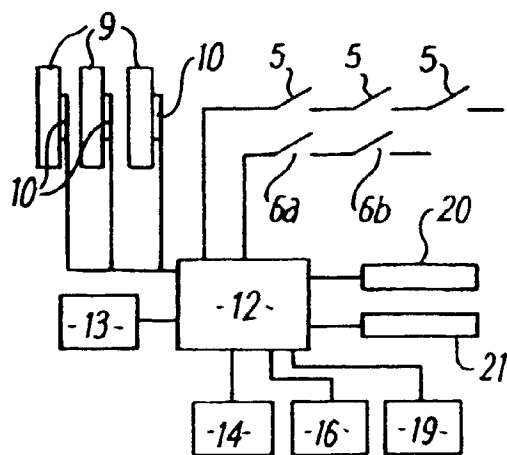

FIG. 3

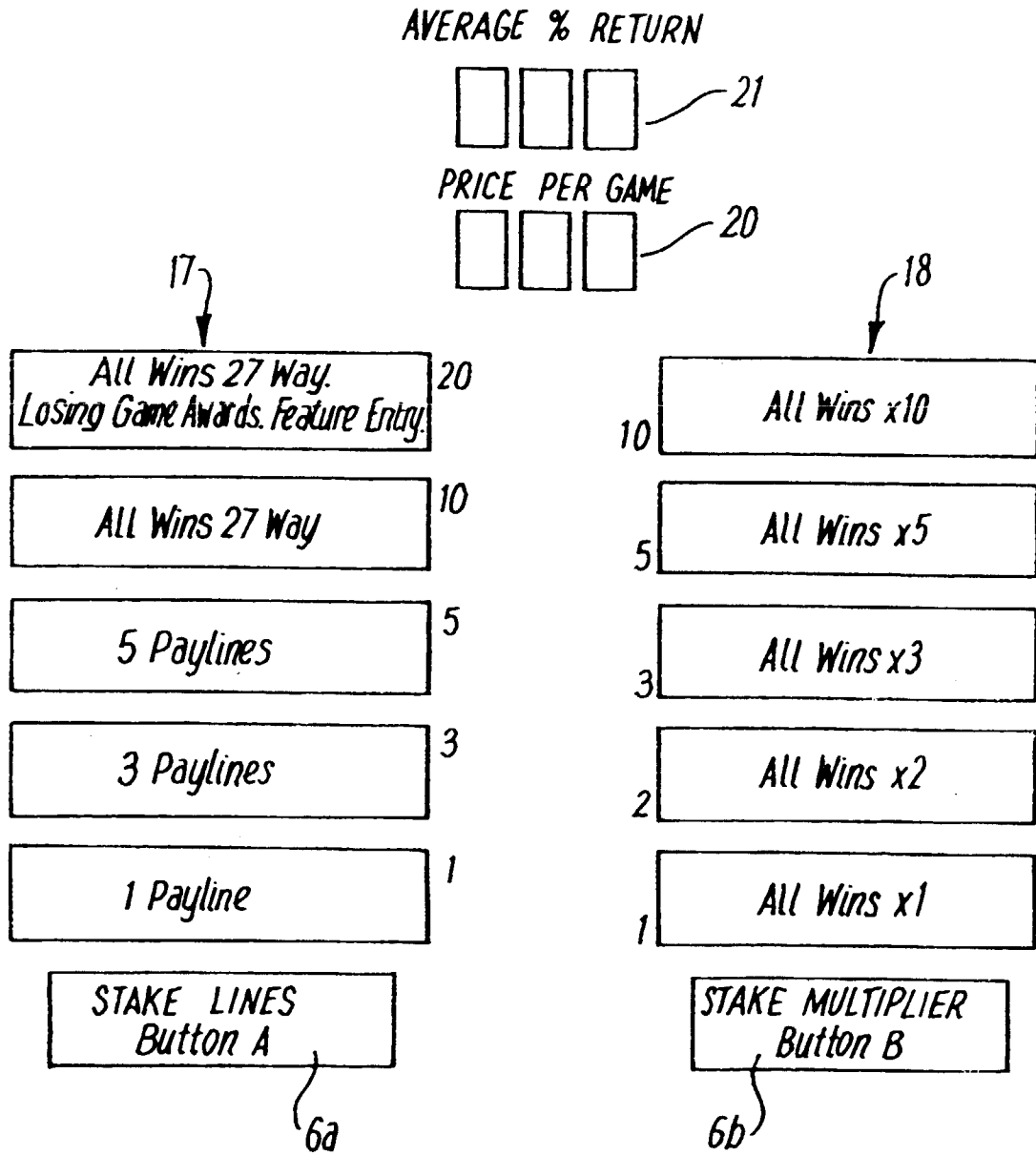

FIG. 2