



Europäisches Patentamt
European Patent Office
Office européen des brevets



(11) **EP 0 899 812 A3**

(12) **EUROPEAN PATENT APPLICATION**

(88) Date of publication A3:
12.05.1999 Bulletin 1999/19

(51) Int Cl.⁶: **H01Q 1/24, H01Q 13/02**

(43) Date of publication A2:
03.03.1999 Bulletin 1999/09

(21) Application number: **98306495.7**

(22) Date of filing: **14.08.1998**

(84) Designated Contracting States:
**AT BE CH CY DE DK ES FI FR GB GR IE IT LI LU
MC NL PT SE**
Designated Extension States:
AL LT LV MK RO SI

(72) Inventor: **Tateishi, Masaaki**
Soma-shi, Fukushima-ken (JP)

(74) Representative: **Kensett, John Hinton**
Saunders & Dolleymore,
9 Rickmansworth Road
Watford, Hertfordshire WD1 7HE (GB)

(30) Priority: **27.08.1997 JP 231193/97**

(71) Applicant: **ALPS ELECTRIC CO., LTD.**
Ota-ku Tokyo 145 (JP)

(54) **BS converter**

(57) A BS converter comprises a box-shaped housing (1) formed of a metallic material and incorporating a circuit board therein, with an electric circuitry being formed on said circuit board; a cylindrical waveguide portion (2) formed of a metallic material and connected at one end thereof to said housing; and a cylindrical horn

portion (3) formed of a metallic material and connected to the opposite end of said waveguide portion, wherein said housing, said waveguide portion and said horn portion are separately formed by deep drawing, said housing and said waveguide portion are connected to each other, and said waveguide portion and said horn portion are connected to each other.

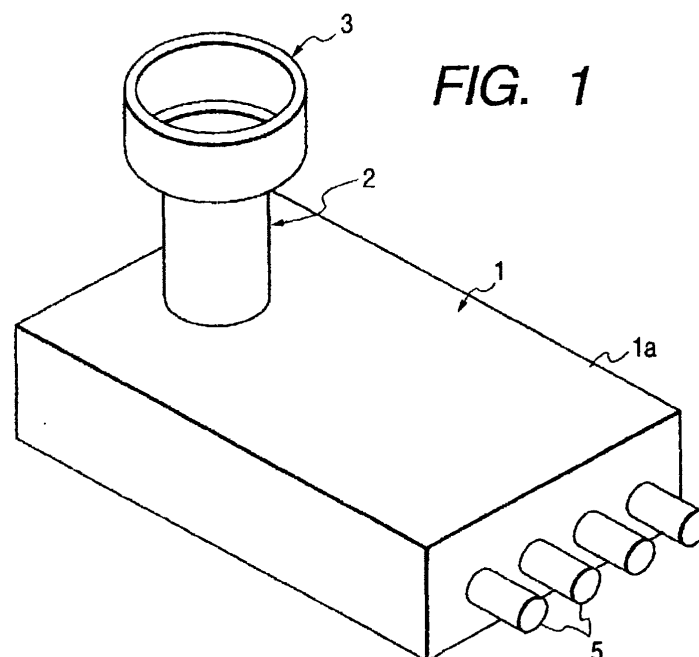

FIG. 1

EP 0 899 812 A3



European Patent
Office

EUROPEAN SEARCH REPORT

Application Number
EP 98 30 6495

DOCUMENTS CONSIDERED TO BE RELEVANT			
Category	Citation of document with indication, where appropriate, of relevant passages	Relevant to claim	CLASSIFICATION OF THE APPLICATION (Int.Cl.6)
Y	EP 0 632 525 A (NIPPON ANTENNA KK) 4 January 1995 * column 4, line 32 - column 6, line 48 * * column 7, line 56 - column 8, line 12; figures 1,2,7 *	1-4	H01Q1/24 H01Q13/02
Y	DE 21 46 832 B (GRÜNZWEIG + HARTMANN) 29 June 1972 * the whole document *	1-4	
A	EP 0 518 615 A (SONY CORP) 16 December 1992 * figures 1,2 *	1	
A	US 3 925 883 A (CAVALEAR CHARLES T) 16 December 1975 * abstract; figures 1-3 *	1	
A	PATENT ABSTRACTS OF JAPAN vol. 010, no. 224 (E-425), 5 August 1986 & JP 61 060001 A (FUJITSU LTD), 27 March 1986 * abstract *		
			TECHNICAL FIELDS SEARCHED (Int.Cl.6)
			H01Q H01P
The present search report has been drawn up for all claims			
Place of search		Date of completion of the search	Examiner
THE HAGUE		22 March 1999	Van Dooren, G
CATEGORY OF CITED DOCUMENTS			
X : particularly relevant if taken alone Y : particularly relevant if combined with another document of the same category A : technological background O : non-written disclosure P : intermediate document		T : theory or principle underlying the invention E : earlier patent document, but published on, or after the filing date D : document cited in the application L : document cited for other reasons & : member of the same patent family, corresponding document	

EPO FORM 1503 03.92 (P04C01)

ANNEX TO THE EUROPEAN SEARCH REPORT
ON EUROPEAN PATENT APPLICATION NO.

EP 98 30 6495

This annex lists the patent family members relating to the patent documents cited in the above-mentioned European search report. The members are as contained in the European Patent Office EDP file on
The European Patent Office is in no way liable for these particulars which are merely given for the purpose of information.

22-03-1999

Patent document cited in search report	Publication date	Patent family member(s)	Publication date
EP 0632525 A	04-01-1995	JP 2759900 B JP 7022804 A	28-05-1998 24-01-1995
DE 2146832 B	29-06-1972	NONE	
EP 0518615 A	16-12-1992	JP 4368002 A DE 69221953 D DE 69221953 T ES 2108730 T US 5276410 A	21-12-1992 09-10-1997 05-02-1998 01-01-1998 04-01-1994
US 3925883 A	16-12-1975	NONE	