



Europäisches Patentamt  
 European Patent Office  
 Office européen des brevets



(11) **EP 0 909 923 A1**

(12) **EUROPEAN PATENT APPLICATION**

(43) Date of publication: **21.04.1999 Bulletin 1999/16**  
 (51) Int. Cl.<sup>6</sup>: **F23Q 7/00**

(21) Application number: **97830505.0**

(22) Date of filing: **10.10.1997**

(84) Designated Contracting States:  
**AT BE CH DE DK ES FI FR GB GR IE IT LI LU MC  
 NL PT SE**  
 Designated Extension States:  
**AL LT LV RO SI**  
 (71) Applicant:  
**Cooper Industries Italia S.p.A.  
 20124 Milano (IT)**

(72) Inventor: **Rossi, Roberto  
 20131 Milano (IT)**  
 (74) Representative:  
**Marchitelli, Mauro et al  
 Buzzi, Notaro & Antonielli d'Oulx  
 Corso Fiume 6  
 10133 Torino (IT)**

(54) **Glow plug with bushing extension**

(57) A glow plug for preheating Diesel engines consisting of a main body (12) and a tubular sheath element (24) projecting from one end (22) of the main body. The plug comprises a bushing (32), coaxial with the tubular sheath element (24), whose length ( $L_1$ ,  $L_2$ ) is selected according to the geometric characteristics it is desired to confer upon the plug. Also described is a method for producing an assortment of plugs with different geometric characteristics and/or thermal behaviours in which identical standard plugs are produced and then personalized and differentiated by the application of appropriate bushing pieces (24) onto the tubular sheath element (24).

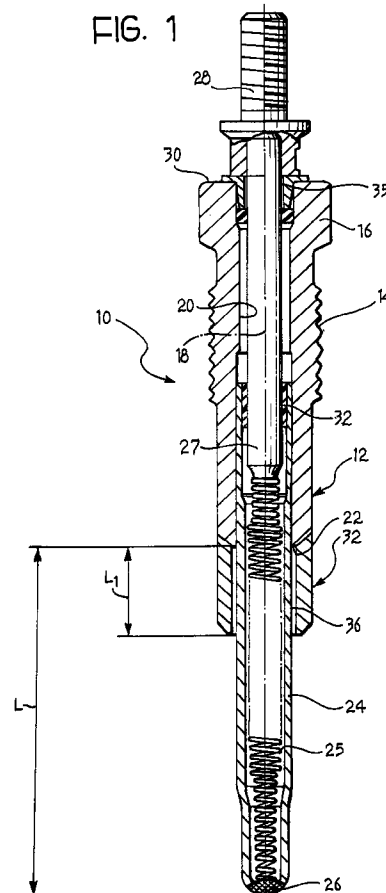

EP 0 909 923 A1

## Description

[0001] The present invention concerns a glow plug for preheating Diesel engines, consisting of a main body having a threaded portion for its connection to the cylinder head of an engine and a tubular sheath element projecting from a first end of the main body, said tubular sheath element being closed at one of its ends and containing a heating resistor that is connected to a terminal projecting from a second end of the main body.

[0002] One of the difficulties that have to be faced by the producers of glow plugs is that they have to handle a rather large assortment of plugs differing from each other by virtue of the geometric characteristics and thermal behaviours necessary to match the type of engine on which they are to be mounted. One of the principal geometric parameters characterizing a glow plug is the length of the portion of the tubular sheath element that projects from the main body.

[0003] Glow plugs may also differ from each other on account of the presence or otherwise of an annular cavity surrounding a section of the tubular sheath element and situated at the end of the main body from which said tubular sheath element projects. All other characteristics being equal, such a cavity makes it possible to vary the thermal behaviour of the plug.

[0004] The need for handling such a large assortment of plugs with different geometric parameters and different thermal properties involves considerable difficulties as regards obtaining supplies of the necessary materials, handling the components and organizing the production cycle.

[0005] The object of the present invention is to provide a glow plug of an improved type that will permit to overcome these difficulties.

[0006] According to the present invention, this object is attained by a plug having the characteristics set out in Claim 1.

[0007] According to the present invention, the assortment of glow plugs with different geometric and thermal characteristics is produced by starting from a single and standardized model of a complete plug on which there is fixed, coaxially with the tubular element, a bushing piece whose length in the direction of the plug axis can be varied according to the thermal and geometric characteristics it is desired to confer upon the glow plug.

[0008] Thanks to the aforesaid characteristics, the assortment of components that have to be handled during the production of the plug is considerably simplified, since it now becomes possible to produce a single and standardized plug that can subsequently be personalized in accordance with the specific situations in which it is to be used by varying the said bushing piece to be applied.

[0009] The bushing piece may either have an internal face directly in contact with the external surface of the tubular sheath element or, alternately, an internal cylindrical surface with a diameter greater than the external

diameter of the tubular sheath element, thereby forming an annular chamber coaxial with a section of the sheath tubular element, for the purpose of varying the thermal characteristics of the plug.

[0010] Further characteristics and advantages of the present invention will be evident in the course of the detailed description which follows, given by way of non-limitative example, with reference to the attached drawings wherein:

- Figure 1 shows an axial section of a glow plug according to the present invention;
- Figures 2a, 2b and 2c show a first example of how a standard glow plug can be personalized in conformity with the present invention; and
- Figures 3a, 3b, 3c and 4a, 4b, 4c show two further examples of how a standard glow plug can be personalized in conformity with the present invention.

[0011] With reference to Figure 1, a glow plug for preheating Diesel engines is indicated 10. The plug 10 comprises a main metal body 12 with a threaded portion 14 that serves for fixing the plug 10 in a hole (not shown) in the cylinder head of a Diesel internal combustion engine. A portion of the head 16 of the main body 12 is shaped in such a way as to have a polygonal profile, a hexagon for example, so that it can be tightened by means of a spanner (not shown). The main body 12 has an elongated shape along the longitudinal axis 18 of the plug and has a through cavity 20 coaxial with the axis 18.

[0012] The main body 12 has a first end 22 from which there projects a tubular sheath element 24 made of an inconel alloy capable of resisting the high temperatures and the chemical aggression of the combustion gases. The tubular sheath element 24 contains a spiral resistor 25 having a first end welded to the closed end 26 of the tubular sheath element 24 and a second end electrically connected to an elongated terminal 27. An insulating powder capable of resisting high temperatures (magnesium oxide, for example) fills the volume within the tubular sheath element 24 and thus ensures electrical insulation between the sheath and the resistor 25. The tubular sheath element 24, complete with resistor 25, terminal 27 and insulating powder, is fixed inside the cavity 20 of the main body 12 in a manner that is known per se. An end portion 28 of the terminal 27 projects from the other end 30 of the main body 12. The terminal 27 is electrically insulated both from the tubular sheath element 24 and the main body 12 by means of the insulating bushes 32 and 35.

[0013] As an alternative, the tubular sheath element 24 could also be obtained as an integral part of the main body 12 in the manner described in European patent application No. 97830307 by the same applicant.

[0014] The glow plug in accordance with the present

Invention is essentially characterized by the presence of an axial prolongation of the main body 12, consisting of an insulating bushing 32 constituting a component separate from and independent of the main body 12. The bushing 32 is fixed to the plug 10 by any appropriate means known to the state of the art, by welding for example, or by brazing, screwing, etc. The bushing piece 32 can be fixed to the end 22 of the main body 12, or to the external surface of the tubular sheath element 24 or to the external cylindrical surface of the main body 12 in the vicinity of its end 22, though in that case shape of the bushing has to be modified from the one shown in Figure 1.

[0015] The bushing 32 has the purpose of varying the geometric characteristics and the thermal behaviour of the plug 10 in accordance with the specific needs of the engine in which the plug is intended to be mounted. More precisely, the plug 10 without the bushing 32 is a plug of standard type in which the length of the portion of the tubular sheath element projecting from the main body 12 is equal to L. The standard plug is of such size that the length L is the greatest of any plug forming part of a given production assortment. The standard plug can be adapted for use with engines that call for a smaller length of the projecting portion of the tubular sheath element 24 by applying the bushing 32. As can readily be seen from Figures 2a, 2b and 2c, the plug of standard configuration indicated by 10a can be appropriately adapted for different uses by applying bushing pieces 32 of different axial lengths and thus obtaining corresponding reductions of the free length of the tubular sheath element 24. In the versions illustrated by Figures 2b and 2c the bushing 32 has an internal surface 34 in contact with the external surface of the tubular sheath element 24.

[0016] The variant illustrated by Figures 3b and 3c illustrates how the application of a bushing piece 32, in addition to changing the geometric characteristics of the plug, can also modify its thermal behaviour as compared with that of the plugs 10b and 10c by providing, for example an annular chamber 36 between the internal surface of the bushing piece 32 and the external surface of the tubular sheath element 24. This gives rise to plugs 10b' and 10c' with a thermal behaviour different from that of the plugs 10b and 10c shown in Figures 2b and 2c, thus further enriching the production assortment that can be obtained by starting with one and the same standard plug 10a.

[0017] Turning now to Figures 4a, 4b and 4c, a further geometric parameter that can be varied by means of the bushing piece 32 according to the present invention is the shape and/or the size of a sealing chamfer 38 provided at the bottom end of the bushing 32 and intended to make tight contact with a similarly shaped surface of the plug seating. In this case, once again, a standard plug 10a can be used to obtain different products 10b" and 10c" that are to all intents and purposes different elements of the production assortment.

[0018] It is perfectly clear that by combining the various lengths of the bushes, the presence or otherwise of an annular chamber between the bushing and the tubular sheath element and various shapes of the sealing chamfer it becomes possible to realize a complete production assortment with an extremely simple and linear production process based on the production of just a few standard plugs that are personalized and differentiated by the application of the bushes 32 only in the very last stage of the production process.

### Claims

1. A glow plug for preheating Diesel engines consisting of:
  - a main body (12) provided with a threaded portion (14) for its connection to the cylinder head of an engine, and
  - a tubular sheath element (24) projecting from a first end (22) of the main body, the tubular sheath element (24) being closed at one end (26) and containing a heating resistor (25) connected to a terminal (27) projecting from the other end (30) of the main body (12), characterized in that it comprises a bushing (32) coaxial with the tubular sheath element (24) and placed on the outside thereof, the bushing (32) being fixed either to the main body (12) or the tubular sheath element (24) and having a length ( $L_1$ ,  $L_2$ ) selected according to the geometric characteristics it is desired to confer upon the plug (10).
2. A plug in accordance with Claim 1, characterized in that the bushing (32) has an internal cylindrical wall in contact with the external cylindrical surface of the tubular sheath element (24).
3. A plug in accordance with Claim 1, characterized in that the bushing (32) has an internal cylindrical wall of a diameter greater than that of the corresponding portion of the tubular sheath element (24), thus defining an annular chamber (36) surrounding a part of the tubular sheath element (24).
4. A plug in accordance with Claim 1, characterized in that the bushing (32) has an end chamfer (38) shaped in such a way as to make the plug (10) fit tightly against a corresponding plug seating in the cylinder head.
5. A method for the production of an assortment of glow plugs for preheating Diesel engines in which the various plugs of the assortment differ from each other by virtue of their geometric characteristics and/or their thermal behaviour, characterized in that there is produced a plurality of standard plugs that

are Substantially identical, each consisting of a main body and a tubular sheath element projecting from one extremity of the main body, and, further, in that the said standard plugs are then differentiated by the application of bushing pieces (32) to the tubular sheath element (24). 5

6. A method as in Claim 5, characterized in that the production of plugs having different lengths of the tubular sheath element (24) projecting from the main body (12) is obtained by applying to the standard plugs (10a) bushing pieces (32) of different lengths ( $L_1$ ,  $L_2$ ) in the direction of the longitudinal axis (18) of the plug (10). 10

15

20

25

30

35

40

45

50

55

FIG. 1

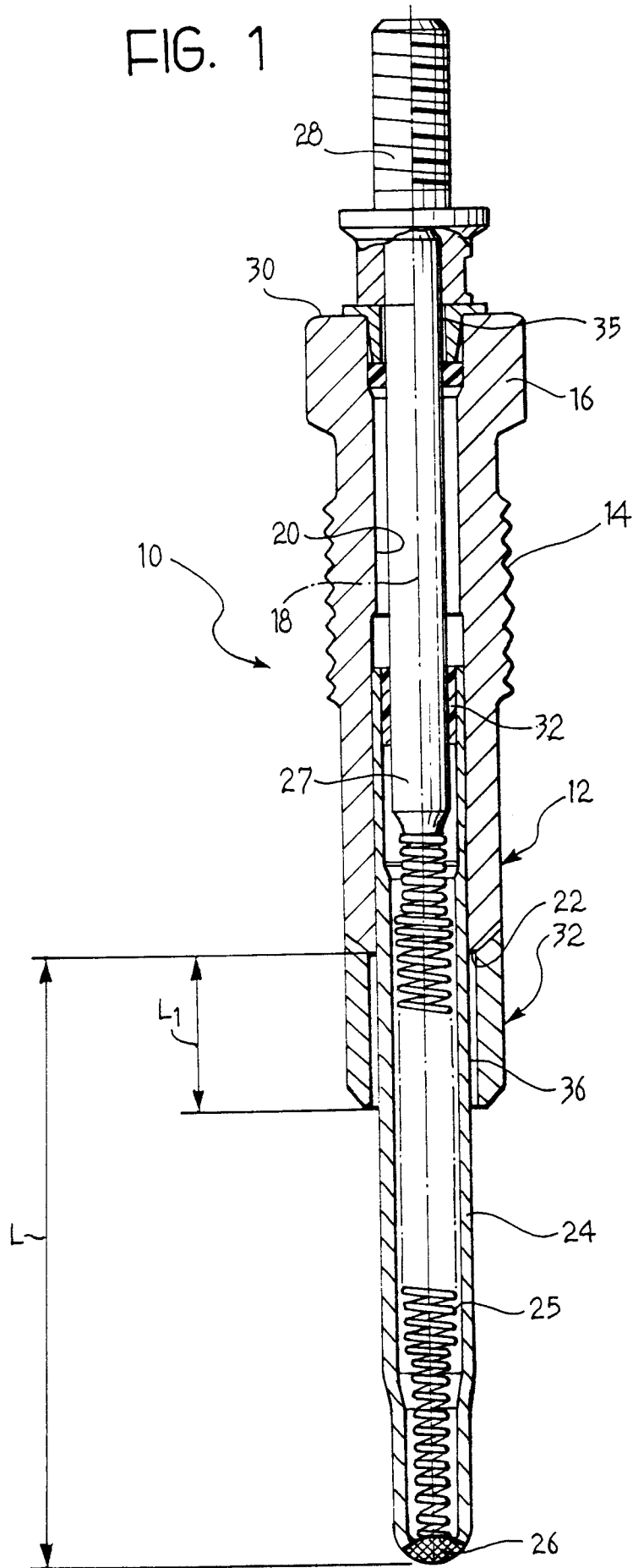

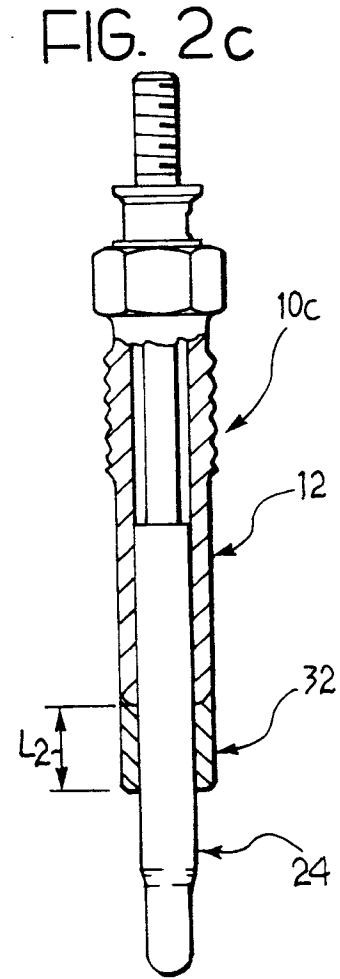
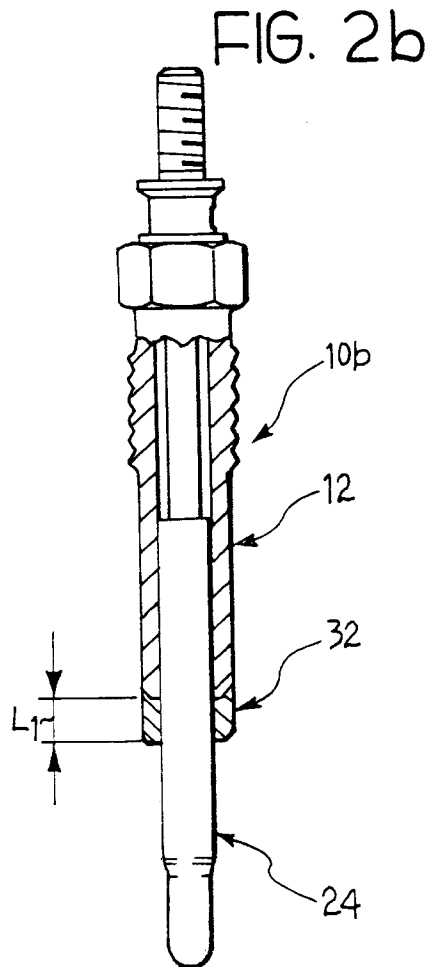
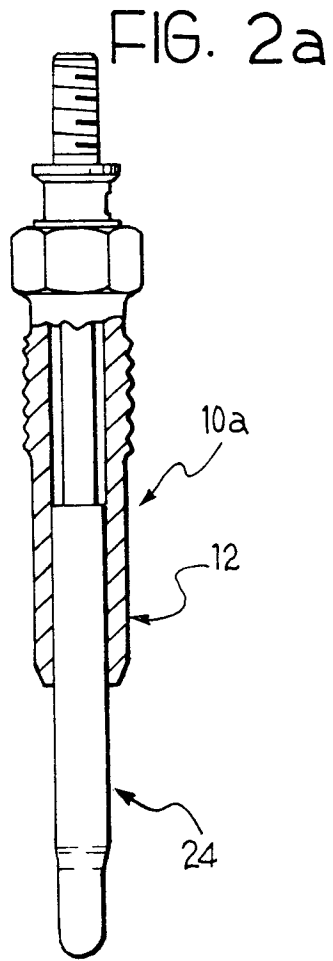

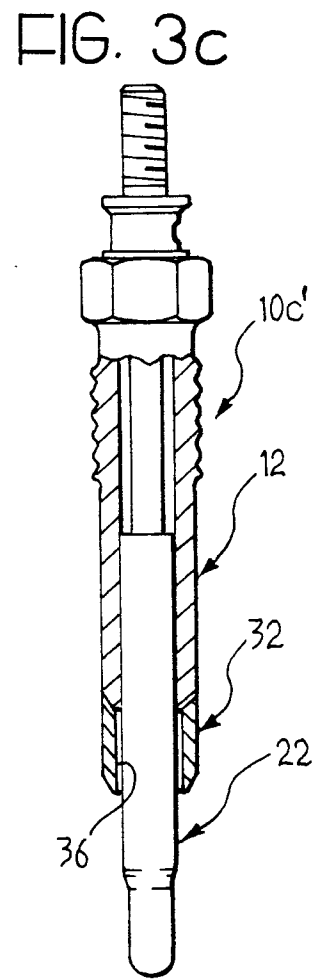
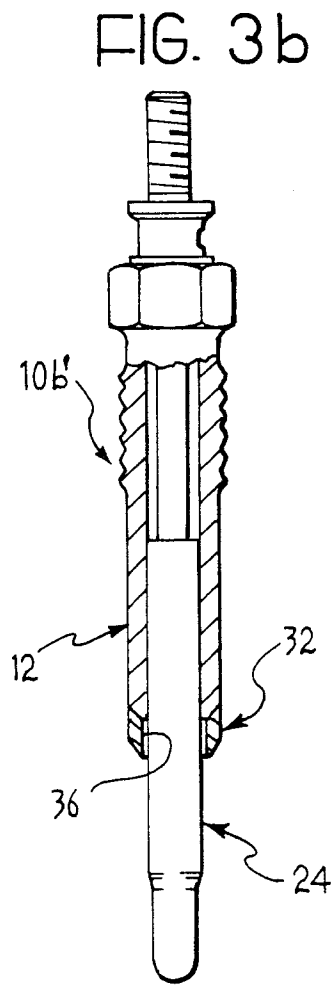
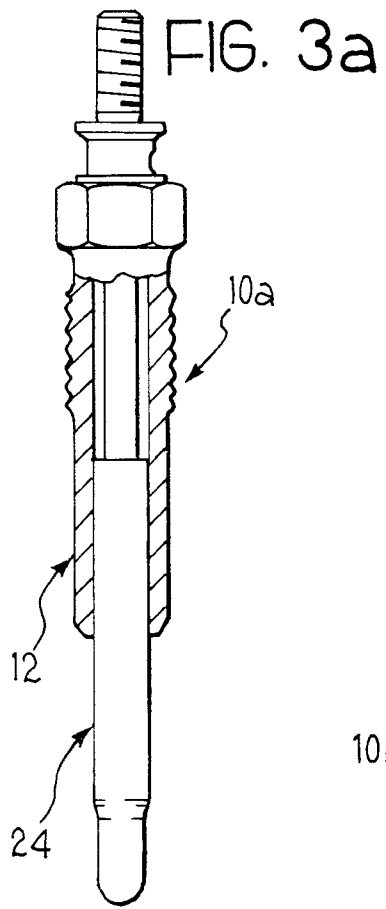

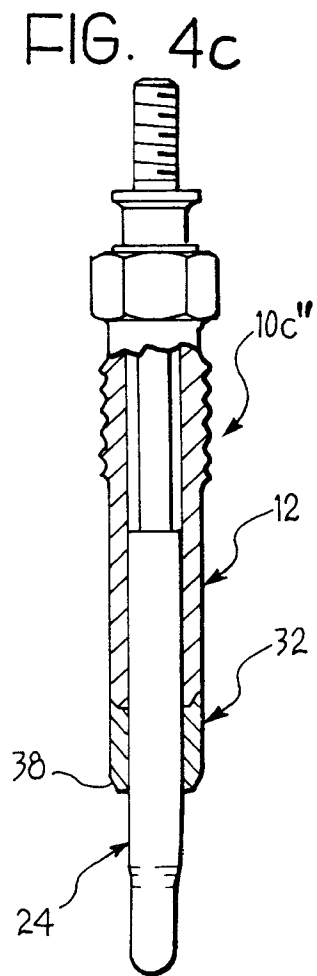
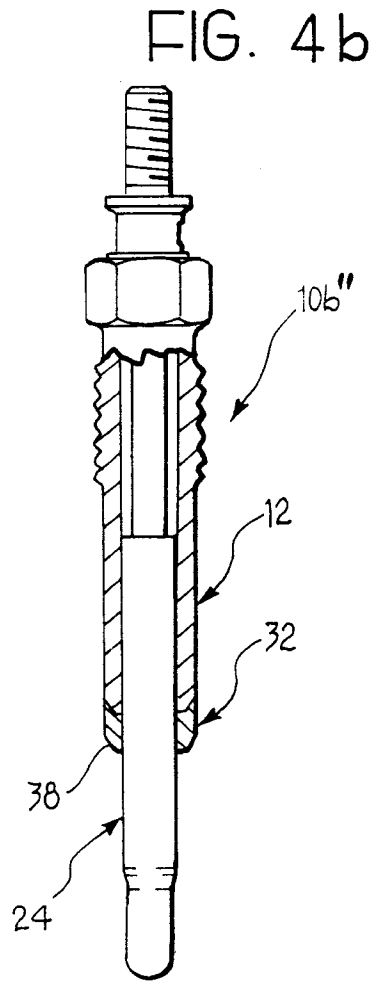
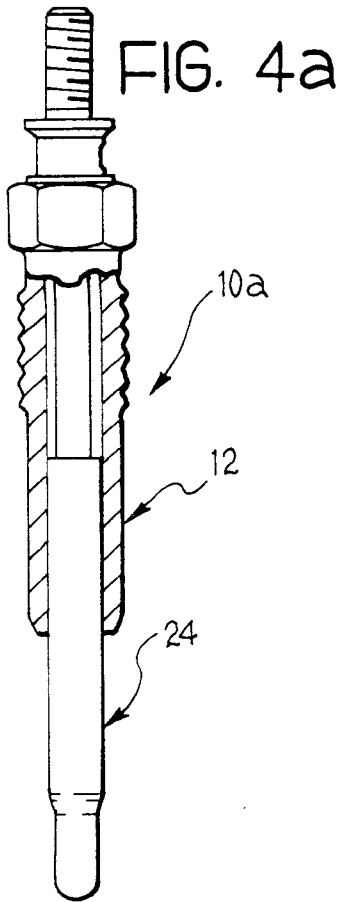



European Patent  
Office

EUROPEAN SEARCH REPORT

Application Number  
EP 97 83 0505

DOCUMENTS CONSIDERED TO BE RELEVANT			
Category	Citation of document with indication, where appropriate, of relevant passages	Relevant to claim	CLASSIFICATION OF THE APPLICATION (Int.Cl.6)
E	DE 196 30 208 A (BOSCH GMBH ROBERT) * the whole document *	1-3	F23Q7/00
A	GB 2 016 596 A (GEN MOTORS FRANCE) * abstract *	1	
			TECHNICAL FIELDS SEARCHED (Int.Cl.6)
			F23Q H01T
The present search report has been drawn up for all claims			
Place of search		Date of completion of the search	Examiner
THE HAGUE		17 March 1998	Vanheusden, J
CATEGORY OF CITED DOCUMENTS			
X : particularly relevant if taken alone Y : particularly relevant if combined with another document of the same category A : technological background O : non-written disclosure P : intermediate document		T : theory or principle underlying the invention E : earlier patent document, but published on, or after the filing date D : document cited in the application L : document cited for other reasons & : member of the same patent family, corresponding document	

EPO FORM 1503 03 82 (P04C01)