

(19)



Europäisches Patentamt
European Patent Office
Office européen des brevets



(11)

EP 0 911 482 A2

(12)

EUROPEAN PATENT APPLICATION

(43) Date of publication:
28.04.1999 Bulletin 1999/17

(51) Int Cl.6: E21B 17/01, E21B 17/02

(21) Application number: 98308732.1

(22) Date of filing: 26.10.1998

(84) Designated Contracting States:
AT BE CH CY DE DK ES FI FR GB GR IE IT LI LU
MC NL PT SE
Designated Extension States:
AL LT LV MK RO SI

(72) Inventor: Finn, Lyle David
Sugar Land, Texas 77479 (US)

(74) Representative: Pilch, Adam John Michael
D. YOUNG & CO.,
21 New Fetter Lane
London EC4A 1DA (GB)

(30) Priority: 27.10.1997 US 958495

(71) Applicant: Deep Oil Technology, Incorporated
Houston, Texas 77079-1709 (US)

(54) Stress relief joints for risers

(57) A stress relief joint (10) for use with riser pipe (22) in floating systems wherein a vessel is subjected to variable motion caused by wind, currents and/or wave action. The riser pipe (22) has one end connectable to the sea floor and an upper portion arranged to pass through an opening at the bottom of the vessel. The lower end, which is connectable to other pipes at the sea floor, is provided with concentric pipes or sleeves (30, 32) around the riser (22). The lower ends of the pipes (30, 32) and riser (22) are welded to a flange (34). The upper end of each of the concentric pipes (30, 32) extends beyond the upper end of the pipe immediately surrounding it. The annulus between the concentric pipes (30, 32) and the riser (22) may be filled with a durable and pliable material (36). Also, shims (38) may be inserted in the annulus at the end of each pipe segment.

FIG. 3

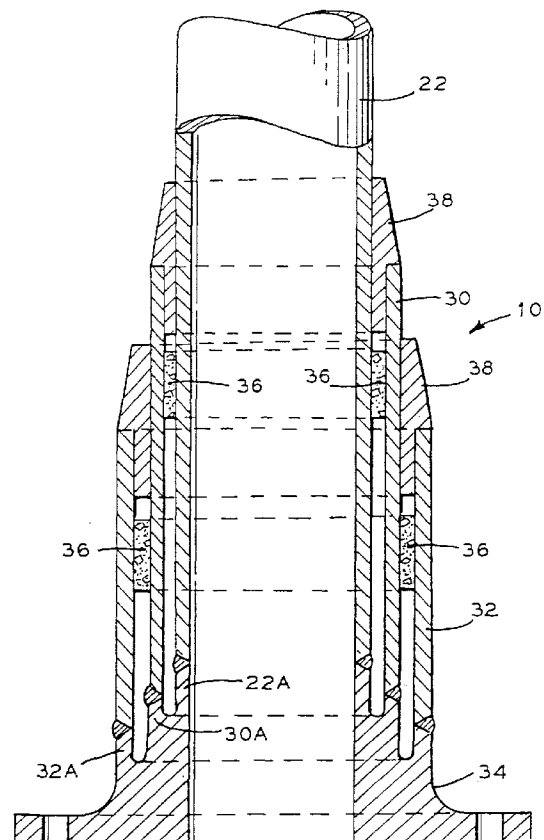

EP 0 911 482 A2

Description

[0001] This invention relates to stress relief joints for risers such as those used in the production of hydrocarbons offshore, and more particularly to such stress relief joints used for risers in conjunction with floating structures.

[0002] In the drilling and production of hydrocarbons offshore, the development of deep water operations from floating vessels has included the use of tendons and risers under tension extending from the vessel to the sea floor. Such floating vessels have included tension buoyant towers and spar structures in which the floating structures extend well below the surface of the water and are subjected to heave, pitch, and roll motions.

[0003] The lower ends of the tendons and risers are connected to the sea floor by means of additional pipes or risers embedded in and grouted to the sea floor. The upper ends of the tendons and risers pass through openings in the keel or bottom portion of the vessels and are supported vertically by tension means located near the water surface.

[0004] When the vessel moves laterally in response to environmental forces, appreciable bending stresses will be induced in the riser in the region just above the point where the riser is attached to the additional pipes at the sea floor. A current approach to the situation has been to use thicker than normal pipes. Disadvantages of this approach are higher manufacturing costs and lower quality consistency in manufacturing of the thicker pipe. This presents a need for a better arrangement for handling the bending stresses induced in the riser at the sea floor.

[0005] Respective aspects of the invention are set out in claims 1, 4, 5 and 9.

[0006] A preferred embodiment of the invention provides a stress relief joint for use with riser pipe in floating systems wherein a vessel is subject to variable motion caused by wind, currents, and/or wave action. The riser pipe has one end connectable to the sea floor and an upper portion arranged to pass through an opening at the bottom of the vessel. The lower end, which is connectable to other pipes at the sea floor, is provided with at least two concentric pipes or sleeves around the riser. The lower ends of the pipes and riser are welded to a flange. The upper end of each of the concentric pipes extends beyond the upper end of the pipe immediately surrounding it. The annulus between the concentric pipes and the riser is preferably filled with a durable and pliable material. Also, shims may be inserted in the annulus at the end of each pipe segment.

[0007] The invention will now be described by way of example with reference to the accompanying drawings, throughout which like parts are referred to by like references, and in which:

Fig. 1 is a schematic view of a floating vessel, sea

floor, and riser interconnecting the vessel and sea floor;

Fig. 2 is an enlarged detail view of a portion of Fig. 1 showing an embodiment of the invention; and

Fig. 3 is an enlarged longitudinal sectional view of part of the arrangement shown in Fig. 2.

[0008] Fig. 1 generally and schematically shows a vessel 20 of spar or tension buoyant tower type with a pipe 22 exiting from its bottom or keel 24 and having a suitable connection 26 to the sea floor 28. Lateral horizontal excursion of the vessel 20 is indicated by its position at 20'. Bending stresses occur on the pipe 22 where it exits the vessel at the keel 24 and at the sea floor connection 26, the dotted lines 22' exaggerating such bending.

[0009] Fig. 2 illustrates the preferred embodiment of the invention. A stress relief joint 10 is generally comprised of sleeves or pipes 30, 32 and a flange 34.

[0010] As seen in Fig. 3, the pipes 30, 32 are received around the riser 22 such that they are concentric with the riser 22. The pipe 30 has an inner diameter larger than the outer diameter of the riser 22 such that an annulus is formed between the riser 22 and the first pipe 30. The pipe 32 has an inner diameter larger than the outer diameter of the pipe 30 such that an annulus is formed between the pipes 30, 32. The upper end of the pipe 30 extends beyond the upper end of the pipe 32 immediately surrounding it.

[0011] The annulus between the concentric pipes 30, 32 and the riser 22 is preferably filled with a durable and pliable material 36. The pliable material 36 helps to insure that the riser 22 and the pipes 30, 32 all deflect laterally substantially the same amount. A suitable material for the operating environment, such as cement grout, is used as the pliable material 36. The lower ends of the pipes 30, 32 and riser 22 are welded to a flange 34.

[0012] Flange 34 is specially formed so as to effectively form short segments of the riser 22 and each pipe 30, 32, respectively indicated by numerals 22A, 30A, and 32A. Each segment extends upwardly from the base of the flange. This feature places the weld between the riser, pipes, and flange some distance away from the most severe fatigue location, where the riser and pipes meet the base of the flange. It can also be seen that the weld point of the riser 22 and each pipe 30, 32 to the flange 34 are spaced apart longitudinally. This allows the flange to be thicker at the base where needed for handling the loads occurring during normal conditions. The lower end of the annulus formed between each segment 22A, 30A, and 32A may be provided with rounded smooth surface profiles as illustrated to reduce the stress concentration associated with sharp corners in the surface profile.

[0013] Shims 38 may be inserted in the annulus at the upper end of each pipe 30, 32 and rigidly held in place

by any suitable means such as welding. Shims 38 may be formed of metal, such as steel, to provide durability and serve as retainers for less rigid materials 36, such as polyurethane.

[0014] Although only two concentric pipes are shown, it should be understood that more may be used, depending upon the application and conditions. It should also be understood that although the preferred embodiment locates the stress relief joint at the lower end of the riser, the joint may be positioned at other locations on the riser where necessary to accommodate appreciable bending loads.

[0015] The invention provides the advantage of lower costs because it may be formed from standard pipe sections that are readily available or can be manufactured using readily available equipment. The design is more reliable than the very thick single pipe designs presently in use because it is easier to control the quality of the thinner pipe material. The concentric pipe design also is more reliable because there is redundancy in the pipe sections. The inner pipe normally has the highest hoop stresses since this pipe is required to contain internal and external pressures. However, with the invention, the bending stresses in the inner most pipe are significantly less than in the outer pipes. Thus, the inner most critical pipe is less likely to experience fatigue damage.

[0016] Because many varying and differing embodiments may be made within the scope of the inventive concept herein taught and because many modifications may be made in the embodiment herein detailed in accordance with the descriptive requirement of the law, it is to be understood that the details herein are to be interpreted as illustrative and not in a limiting sense.

Claims

1. A stress relief joint for use with a riser in floating systems wherein a vessel is subject to variable motion caused by wind, currents, and wave action, the riser having one end connectable to the sea floor and an upper riser portion adapted to pass through an opening at the bottom of the vessel, the stress relief joint comprising:
 - a. a plurality of pipes received around the riser such that an annulus is formed between each pipe and the riser, said pipes being concentric with the riser and having first and second ends, with the first end of each pipe extending beyond the first end of the immediately surrounding pipe; and
 - b. a flange rigidly connected to the riser and the second end of said pipes.
2. The stress relief joint of claim 1, further comprising a pliable material received in the annulus formed between said pipes and the riser.

3. The stress relief joint of claim 1, further comprising a shim rigidly attached between each of said pipes and the riser at the first end of each of said plurality of pipes.

4. A stress relief joint for use with a riser in floating systems wherein a vessel is subject to variable motion caused by wind, currents, and wave action, the riser having one end connectable to the sea floor and an upper riser portion adapted to pass through an opening at the bottom of the vessel, the stress relief joint comprising:
 - a. a plurality of pipes received around the riser such that an annulus is formed between each pipe and the riser, said pipes being concentric with the riser and having first and second ends, with the first end of each pipe extending beyond the first end of the immediately surrounding pipe;
 - b. a flange rigidly connected to the riser and the second end of said pipes;
 - c. a pliable material received in the annulus formed between said pipes and the riser; and
 - d. a shim rigidly attached between each of said pipes and the riser at the first end of each of said plurality of pipes.

5. A stress relief joint for use with a riser in floating systems wherein a vessel is subject to variable motion caused by wind, currents, and wave action, the riser having one end connectable to the sea floor and an upper riser portion adapted to pass through an opening at the bottom of the vessel, the stress relief joint comprising:
 - a. a plurality of pipes received around the lower end of the riser such that an annulus is formed between each pipe and the riser, said pipes being concentric with the riser, and the upper end of each of said pipes extending beyond the upper end of the immediately surrounding pipe; and
 - b. a flange rigidly connected to the lower end of the riser and said pipes.

6. The stress relief joint of claim 5, further comprising a pliable material received in the annulus formed between said pipes and the riser.
7. The stress relief joint of claim 5, wherein said plurality of pipes comprises first and second pipes.
8. The stress relief joint of claim 5, further comprising a shim rigidly attached between each of said pipes and the riser at the upper end of each of said plurality of pipes.

9. A stress relief joint for use with a riser in floating systems wherein a vessel is subject to variable motion caused by wind, currents, and wave action, the riser having one end connectable to the sea floor and an upper riser portion adapted to pass through an opening at the bottom of the vessel, the stress relief joint comprising:
- a. first and second pipes received around the lower end of the riser such that an annulus is formed between each pipe and the riser, said first and second pipes being concentric with the riser, and the upper end of said first pipe extending beyond the upper end of the second pipe;
 - b. a flange rigidly connected to the lower end of the riser and said pipes; and
 - c. a pliable material received in the annulus formed between said pipes and the riser.
10. The stress relief joint of claim 9, further comprising a shim rigidly attached between each of said pipes and the riser at the upper end of each of said plurality of pipes.

5

10

15

20

25

30

35

40

45

50

55

FIG. 1

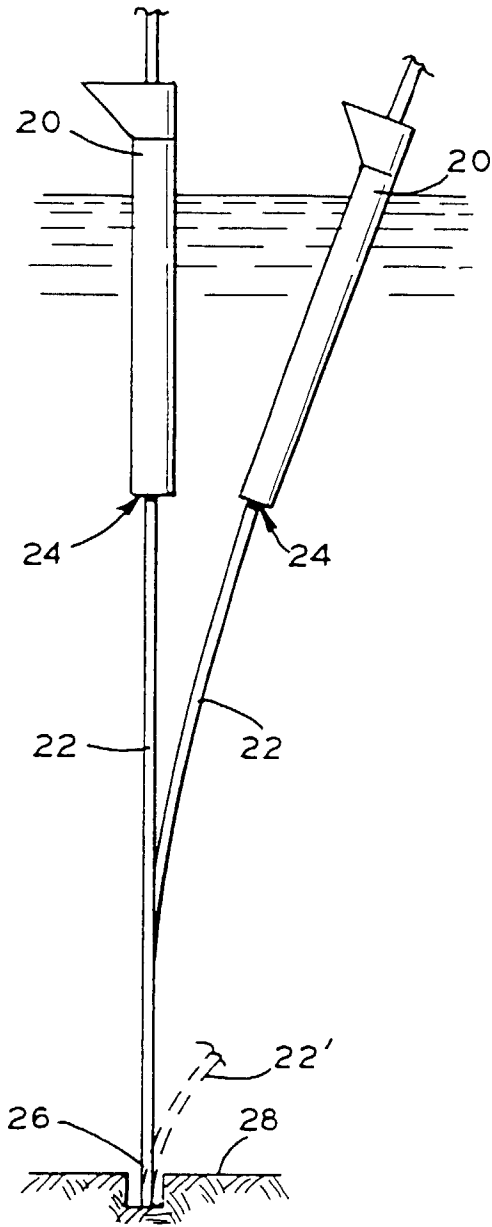

FIG. 2

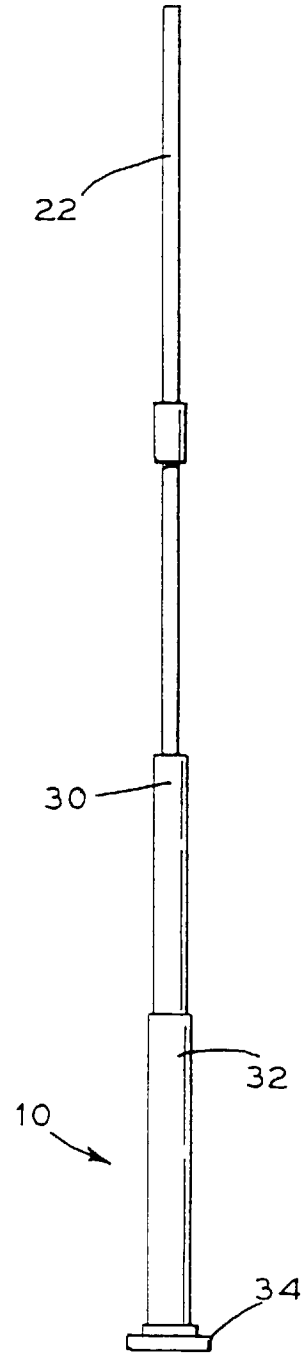

FIG. 3

