



Europäisches Patentamt
European Patent Office
Office européen des brevets



(11) **EP 0 915 669 B1**

(12) **EUROPEAN PATENT SPECIFICATION**

(45) Date of publication and mention
of the grant of the patent:

05.03.2003 Bulletin 2003/10

(21) Application number: **97931778.1**

(22) Date of filing: **04.07.1997**

(51) Int Cl.7: **A43B 7/12, A43B 7/36**

(86) International application number:
PCT/EP97/03550

(87) International publication number:
WO 98/001049 (15.01.1998 Gazette 1998/02)

(54) **WATERPROOF FOOTWEAR**

WASSERDICHTES SCHUHWERK

CHAUSSURES IMPERMEABLES A L'EAU

(84) Designated Contracting States:
AT BE CH DE DK ES FR GB GR IE IT LI NL PT SE

(30) Priority: **04.07.1996 DE 19627030**

(43) Date of publication of application:
19.05.1999 Bulletin 1999/20

(73) Proprietor: **W.L. GORE & ASSOCIATES GmbH**
85640 Putzbrunn (DE)

(72) Inventor: **SILVA, Jose, Quinta do Ariero,30**
P-4520 Feira (PT)

(74) Representative: **Hirsch, Peter, Dipl.-Ing.**
Klunker Schmitt-Nilson Hirsch
Winzererstrasse 106
80797 München (DE)

(56) References cited:
EP-A- 0 284 638 **EP-A- 0 736 266**
WO-A-92/20249 **DE-A- 3 447 205**
DE-A- 4 419 802

- **PATENT ABSTRACTS OF JAPAN vol. 096, no. 012, 26 December 1996 & JP 08 196305 A (ASAHI CORP), 6 August 1996,**

EP 0 915 669 B1

Note: Within nine months from the publication of the mention of the grant of the European patent, any person may give notice to the European Patent Office of opposition to the European patent granted. Notice of opposition shall be filed in a written reasoned statement. It shall not be deemed to have been filed until the opposition fee has been paid. (Art. 99(1) European Patent Convention).

Description

[0001] The invention relates to waterproof footwear with an upper material shaft consisting of an upper material, with a functional layer shaft being arranged inside of the upper material shaft and incorporating a waterproof, functional layer, with an insole and an outsole, wherein the sole-facing end areas of both the upper material shaft and of the functional layer shaft are turned around the circumferential edge of the insole, in case of the sole-facing end area of the upper material shaft in the form of a lasting allowance. The functional layer may in addition to being waterproof also be water vapor permeable.

[0002] Footwear of this type is conventionally either lined with a sock-like insert consisting of a functional layer material (also known by the technical expression "bootie") to protect the foot fully from penetrating water, or a construction of the type described in the beginning is used wherein the sole-facing open end of both the upper material shaft and the functional layer shaft are lasted and glued around a last holding the insole in an adhesive lasting process.

[0003] The solution with the sock-like functional layer insert makes the footwear reliably waterproof, but may be disadvantageous if for some reason a material different from the functional layer or a material with different properties than the functional layer were preferable in the sole area.

[0004] German utility model DE-U-9113139 quotes a bicomponent bootie whose shaft part consists of a functional layer and whose sole area consists of a two-dimensionally stretchable plastic film made from a different material than the functional layer material, but one which is desired to be waterproof. The reason for the stretchability is that the foot stretches in two dimensions when walking whereas conventional functional layer materials stretch in one dimension only entailing the danger of excessive loads in the sole area of the bootie.

[0005] In working footwear which is designed to conduct electric charges away from the foot via the sole the functional layer constitutes a barrier to the discharge of electrical charges because conventional functional materials, for example microporous polytetrafluoroethylene (PTFE), have a high electrical insulating capacity.

[0006] In footwear construction with the functional layer shaft which is open towards the sole side the materials located within the lasting allowance of the functional layer shaft can be selected adequately so that properties can be achieved which would have been impossible if a sock-like functional layer insert had been used. For example, antistatic materials may be used, i.e. materials which do not constitute a barrier to the dissipation or discharge of static electrical charges.

[0007] A lasting process is rather work-intensive and requires a lasting machine to produce the lasting allowance. In conventional footwear, wherein a lasting allowance is produced both for the upper material shaft and

for the functional layer shaft, two lasting processes and two lasting machines are required, which is rather cost-intensive.

[0008] Document DE-A-4 419 802 discloses waterproof footwear with the features of the preamble of claim 1.

[0009] The object of the present invention is to provide for waterproof footwear of the type described above which offers considerable freedom in sole material selection and which does not require two lasting processes to produce the footwear.

[0010] To solve this object the invention provides for waterproof footwear with an upper material shaft made up of an upper material, with a functional layer shaft arranged inside of the upper material shaft and comprising a waterproof functional layer, with an insole and with an outsole, wherein the sole-facing end area of both the upper material shaft and the functional layer shaft is turned around the circumferential edge of the insole between the insole and the outsole,

wherein the sole-facing end area of the upper material shaft is connected in the form of a lasting allowance, the sole-facing opening of the functional layer shaft is closed by means of a closing piece which is sewn to the edge of this opening and which extends underneath the insole, and wherein between the closing piece and the lasting allowance of the upper material shaft a sealant is arranged which seals the closing piece itself as well as the seam between the functional layer shaft and the closing piece.

[0011] According to a preferred embodiment of the invention the functional layer, in addition to being waterproof, is also water vapor permeable. In another preferred embodiment the upper material is also water vapor permeable, which allows comfortable breathable waterproof footwear to be produced.

[0012] Further embodiments of the footwear of the invention are stated in the sub-claims.

[0013] "Waterproof footwear" is defined to mean that no liquid water leaks through the footwear, with no pressure being applied.

[0014] The Two Hour Hydro Test is used to test for waterproofness in footwear. This test was performed at ambient temperature and humidity. The footwear was checked to make sure that it was completely dry. A paper towel was folded in half, lengthwise, so that it was double, i.e., had two layers, and was set on a clean benchtop. The paper towel functions as a blotter. The footwear was then set on this paper towel blotter.

[0015] Approximately 500-600 mls of clean, tap water was poured into the footwear, filling it to the top of the heel. The volume of water will vary with the size of the footwear. The paper towel blotter was then observed for wet spots, at fifteen minute intervals during a two hour period. The footwear was rated to Pass, if the paper tow-

el blotter remained dry, i.e., no water leaked through the the footwear. The footwear was rated to Fail, if there were wet spots on the paper towel blotter, indicating where water had seeped through the footwear and collected on the paper towel.

[0016] "Waterproof functional layer" as used herein is meant a functional layer having water-penetration-resistance (hydrostatic resistance) of 6.8 kPa (1.0 psi) or more.

[0017] The Low Pressure Hydrostatic Resistance Test (WEP) is used to indicate the waterproofness of the functional layer. It consists essentially of forcing water against one side of a test piece, and observing the other side of the test piece for indications of water penetration through it. The test specimen was clamped and sealed between rubber gaskets in a fixture that holds the test piece. One surface of the test specimen was in contact with the water and the other side faced upward, open to the atmosphere, for close observation. Air was removed from inside the fixture and pressure was applied to the inside surface of the test piece, over an area of 7.62 cm (3.0 inches) diameter, as water was forced against it. The water pressure on the test piece was increased to about 6.9 kPa (1.0 psi) by a pump connected to a water reservoir, as indicated by an appropriate gauge and regulated by an in-line valve.

The surface of the test piece was watched closely for the appearance of any water forced through the material. Water seen on the surface is interpreted as a leak. The sample surface is observed for one minute at test pressure, at which time the number of leaks are counted and recorded.

[0018] Water-vapor-permeable as used herein is meant having a water-vapor-transmission (WVTR) rate of 100 g/m²/24-hours or more.

[0019] A description of the test employed to measure water vapor transmission rate (WVTR) is given below. In the procedure, approximately 70 ml. of a solution consisting of 35 parts by weight of potassium acetate and 15 parts by weight of distilled water was placed into a 133 ml. polypropylene cup, having an inside diameter of 6.5 cm. at its mouth. An expanded polytetrafluoroethylene (PTFE) membrane having a minimum WVTR of approximately 85.000 g/m²/24 hrs. as tested by the method described in U.S. Patent 4,862,730 to Crosby and available from W. L. Gore & Associates, Inc. of Newark, Delaware, was heat sealed to the lip of the cup to create a taut, leakproof, microporous barrier containing the solution.

A similar expanded PTFE membrane was mounted to the surface of a water bath. The water bath assembly was controlled at 23°C plus 0.2°C, utilizing a temperature controlled room and a water circulating bath.

The sample to be tested was allowed to condition at a temperature of 23°C and a relative humidity of 50% prior to performing the test procedure. Samples were placed so the microporous polymeric membrane was in contact with the expanded polytetrafluoroethylene membrane

mounted to the surface of the water bath and allowed to equilibrate for at least 15 minutes prior to the introduction of the cup assembly.

The cup assembly was weighed to the nearest 1/1000g. and was placed in an inverted manner onto the center of the test sample.

Water transport was provided by the driving force between the water in the water bath and the saturated salt solution providing water flux by diffusion in that direction.

The sample was tested for 60 minutes and the cup assembly was then removed, weighed again within 1/1000g.

[0020] The WVTR of the sample was calculated from the weight gain of the cup assembly and was expressed in grams of water per square meter of sample surface area per 24 hours.

[0021] According to the invention in footwear of the type described above the sole-side opening of the functional layer shaft is closed by means of a closing piece of any sewable material extending underneath the insole and being sewn to the edge of this opening and that between the closing piece and the lasting allowance of the upper material shaft there is a waterproof sealing material which seals both the seam between the functional layer shaft and the closing piece and the closing piece itself.

[0022] In a footwear of the invention almost any material may be selected as "closing piece", as long as it can be sewn to the functional layer shaft. For example an electrically conductive material can be used for an antistatic footwear so that static charges can be dissipated and removed from the footwear. In this case electrically conductive materials are also used for the insole, the sealing material and the outsole.

[0023] German utility model DE-U-295 05 886 and European patent application EP-A-96 104 891, containing the same disclosure, both of which were published after the priority date of the present patent application, describe footwear which dissipates static electrical charges and has an outsole consisting of an electrically conductive material, a bootie consisting of a functional layer and an insole arranged in between. The insole consists of an electrically conductive material, either fully or only in the foot's ball area. The bootie, too, consists of an electrically conductive material, either fully or only in the sole area or only in the foot's ball area. For this purpose either a functional layer material is used which has been rendered electrically conductive by embedding electrically conductive particles or the functional layer material is replaced by a different electrically conductive material in the foot's ball or sole area, e.g. by sewing such a material into a bootie hole in the foot's ball or sole area. Since this other material must be waterproof, there is only a limited number of materials to choose from. An inlay sole is arranged inside of the bootie.

[0024] Since in the footwear construction of the present invention there is a sealing material between the

lasting allowance of the upper material shaft and the closing piece, which seals both the seam between the functional layer shaft and the closing piece and the closing piece itself against the ingress of moisture towards the insole, a waterproof footwear construction is ensured despite the seam, even if the closing piece consists of a material which is not waterproof.

[0025] Preferably the functional layer shaft and the closing piece are sewn together by means of a Strobel seam. The sealant may be an adhesive-like material or a film or plate like material, e.g. a material whose adhesive force can be activated by, but not limited to heat, UV or infrared radiation or chemical curing systems. It can be made of any material, which allows the sole region of the footwear to be waterproofed, in particular polymers, preferably polyurethane or polytetrafluoroethylene.

[0026] An electrically conductive sewing material may be used to produce the seam between the closing piece and the functional layer shaft, either in addition to a closing piece consisting of an electrically conductive material or instead of using an electrically conductive material for the closing piece. An adhesive bond may be provided between the end area of the functional layer shaft and/or the closing piece and the insole on the one hand and the lasting allowance of the upper material shaft on the other hand. An outsole may be mounted to the lasting allowance and the sealing material either by injection molding or glueing. The outsole may be made from leather, rubber, thermoplastic elastomers or polyurethanes. Polyurethane is preferable if injection molding is used.

[0027] The functional layer material may be made of any waterproof material or film, but is preferably microporous expanded PTFE, with a monolithic coating. Materials suitable for the functional layer comprise microporous expanded polytetrafluoroethylene (PTFE) as described in US patent specifications 3,953,566 and 4,187,390; expanded PTFE provided with hydrophilic impregnating agents and/or layers as described in US patent specification 4,194,041; breathable polyurethane layers; or elastomers, such as copolyetherester and laminates thereof as described in US patent specifications 4,725,481 and 4,493,870.

[0028] In the following the invention will be explained in more detail with reference to an embodiment which is schematically shown in the attached Figures.

Figure 1 is a schematic view of footwear in accordance with the invention and with an injection molded outsole. Figure 2 is a schematic view of footwear in accordance with the invention and with an adhesively attached outsole.

[0029] The embodiment shown in Figure 1 comprises an upper material shaft 11 consisting of an upper material, such as leather. On the inside of the upper material shaft 11 there is a functional layer shaft 13 which consists of a waterproof, water vapor permeable functional layer, preferably of expanded microporous PTFE. The

functional layer may be part of a laminate which comprises at least one textile layer in addition to the functional layer, e.g. a textile lining layer located on the inside of the laminate. Preferably a backing material is provided on the outside of the functional layer, i.e. a thin textile layer to protect the functional layer towards the upper material layer 11.

[0030] The footwear comprises an insole 15 which may consist of a cardboard or leather-like material or of plastic, and an outsole 29, which may consist of injection molded polyurethane. The sole-side end 17 of the functional layer shaft is turned around the insole circumference 19 towards the outsole-facing circumferential edge of the insole. An sole-facing opening of the functional layer shaft 13, which remains after this step, is closed by means of a closing piece 21 which is attached to the sole-side edge of the functional layer shaft 13 by means of a Strobel-type seam 23.

[0031] The sole-facing opening of the functional layer shaft 13 may be closed before the functional layer shaft is pulled over the last (not shown) with the attached insole 15.

[0032] Underneath the turned over sole-facing end 17 of the functional layer shaft 13 and the closing piece 21 there is a sealing material 25 which extends so far that it covers and seals at least the entire closing piece 21 and the Strobel seam 23, making the sole area of the footwear waterproof.

[0033] The sole-side end 27 of the upper material shaft 11 is lasted around the functional layer shaft to the underside of the sealant material 25 by means of an adhesive lasting process.

[0034] The connection between the insole 15 and the turned around end 17 of the functional layer insert 13 and/or the closing piece 21 may be effected, e.g., by glueing.

[0035] The closing piece 21 may consist of any desirable material, the only condition being that it must be sewable. For example there is a material commercially available from USM Corp. under the trade name of TEXON which is suitable for this purpose, if static charges are to be dissipated via the sole construction. Examples of electrically conductive sewing materials are carbon, nickel plated or silver plated threads, such as are sold under the trade name X-STATIC by Saquoit Industries. An example of a suitable sealant material is, e.g., seam sealing tape material as used according to the state of the art for sealing seams in functional layers.

[0036] The footwear construction shown in Figure 2 is the same as in Figure 1, with the exception, that the outsole is adhesively attached instead of injection molded and made of e.g., prefabricated plastic or leather.

55 Claims

1. A waterproof footwear with an upper material shaft (11),

with a functional layer shaft (13) arranged on the inside of the upper material shaft (11), containing a waterproof functional layer;

with an insole (15);

and with an outsole (29),

wherein the sole-facing end area (27, 17) of the functional layer shaft (13) is turned around to be parallel to the insole (15);

the sole-facing opening of the functional layer shaft (13) is closed by means of a closing piece (21) which is sewn to the edge of this opening (23) and which extends parallel to the insole (15),

characterized in that

the sole-facing end area of both the upper material shaft (11) and the functional layer shaft (13) is turned around the circumferential edge of the insole (15) between the insole (15) and the outsole (29); the sole-facing end area (27) of the upper material shaft (11) is connected in the form of a lasting allowance (27);

the closing piece (21) extends underneath the insole (15),

and between the closing piece (21) and the lasting allowance (27) of the upper material shaft (11) a waterproof sealant is arranged (25) which seals the closing piece (21) itself as well as the seam (23) between the functional layer shaft (13) and the closing piece (21).

2. A footwear of Claim 1, wherein the functional layer is water vapor permeable.
3. A footwear of claim 1 or 2, wherein the upper material shaft (11) is water vapor permeable.
4. A footwear of one of Claims 1 to 3, wherein the functional layer shaft (13) and the closing piece (21) are sewn together by means of a Strobel seam (23).
5. A footwear of one of Claims 1 to 4, wherein an adhesive-like sealant material (25) is provided.
6. A footwear of one of Claims 1 to 4, wherein a film or plate-like sealant material is provided.
7. A footwear of one of Claims 1 to 6, wherein the closing piece (21) consists of an electrically conductive material.
8. A footwear of Claim 7, wherein the seam (23) connecting the functional layer shaft (13) and the closing piece (21) is sewn with an electrically conductive sewing material.
9. A footwear of one of Claims 1 to 8, wherein an outsole (29) is mounted on the lasting allowance (27) of the upper material shaft (11) and the sealant material (25).

10. A footwear of Claim 9, wherein the outsole (29) is mounted to the footwear by injection molding.

11. A footwear of Claim 9, wherein the outsole (29) is adhesively attached.

12. A footwear of one of Claims 1 to 11, wherein the functional layer consists of expanded, microporous PTFE.

Patentansprüche

1. Wasserdichtes Schuhwerk mit einem Obermaterialschaft (11), mit einem Funktionsschichtschaff (13), der auf der Innenseite des Obermaterialschafts (11) angeordnet ist und eine wasserdichte Funktionsschicht enthält; mit einer Brandsohle (15); und mit einer Laufsohle (29), wobei der sohlenseitige Endbereich (27, 17) des Funktionsschichtschaffs (13) derart umgeschlagen ist, dass er parallel zu der Brandsohle (15) ist; wobei die sohlenseitige Öffnung des Funktionsschichtschaffs (13) mittels eines Schließstücks (21) geschlossen ist, das mit dem Rand dieser Öffnung (23) vernäht ist und das sich parallel zu der Brandsohle (15) erstreckt, **dadurch gekennzeichnet, dass** der sohlenseitige Endbereich sowohl des Obermaterialschafts (11) als auch des Funktionsschichtschaffs (13) um den Umfangsrand der Brandsohle (15) herum zwischen Brandsohle (15) und Laufsohle (29) geschlagen ist; **dass** der sohlenseitige Endbereich (27) des Obermaterialschafts (11) in Form eines Zwickeinschlages (27) angebracht ist; **dass** sich das Schließstück (21) unterhalb der Brandsohle (15) erstreckt, und dass zwischen dem Schließstück (21) und dem Zwickeinschlag (27) des Obermaterialschafts (11) ein wasserdichtes Dichtungsmaterial angeordnet ist (25), das sowohl das eigentliche Schließstück (21) als auch die Naht (23) zwischen dem Funktionsschichtschaff (13) und dem Schließstück (21) abdichtet.
2. Schuhwerk nach Anspruch 1, wobei die Funktionsschicht wasserdampfdurchlässig ist.
3. Schuhwerk nach Anspruch 1 oder 2, wobei der Obermaterialschaft (11) wasserdampfdurchlässig ist.
4. Schuhwerk nach einem der Ansprüche 1 bis 3, wobei der Funktionsschichtschaff (13) und das Schließstück (21) mittels einer Strobelnaht (23) mit-

einander vernäht sind.

5. Schuhwerk nach einem der Ansprüche 1 bis 4, wobei ein kleberartiges Dichtungsmaterial (25) vorgesehen ist.
6. Schuhwerk nach einem der Ansprüche 1 bis 4, wobei ein folien- oder plattenartiges Dichtungsmaterial vorgesehen ist.
7. Schuhwerk nach einem der Ansprüche 1 bis 6, wobei das Schließstück (21) aus einem elektrisch leitfähigen Material besteht.
8. Schuhwerk nach Anspruch 7, wobei die den Funktionsschicht (13) und das Schließstück (21) verbindende Naht (23) mit elektrisch leitfähigem Nähmaterial genäht ist.
9. Schuhwerk nach einem der Ansprüche 1 bis 8, wobei eine Laufsohle (29) auf den Zwickelschlag (27) des Obermaterials (11) und das Dichtungsmaterial (25) aufgebracht ist.
10. Schuhwerk nach Anspruch 9, wobei die Laufsohle (29) durch Aufspritzen an dem Schuhwerk angebracht ist.
11. Schuhwerk nach Anspruch 9, wobei die Laufsohle (29) aufgeklebt ist.
12. Schuhwerk nach einem der Ansprüche 1 bis 11, wobei die Funktionsschicht aus gerecktem, mikro-porösen PTFE besteht.

Revendications

1. Chaussure imperméable à l'eau
 - avec une tige de matière supérieure (11),
 - avec une tige de couche fonctionnelle (13) disposée sur l'intérieur de la tige de matière supérieure (11), contenant une couche fonctionnelle imperméable à l'eau;
 - avec une semelle intérieure (15);
 - et avec une semelle extérieure (29),
 - dans laquelle la zone d'extrémité faisant face à la semelle (27, 17) de la tige de couche fonctionnelle (13) est retournée pour être parallèle à la semelle intérieure (15);
 - l'ouverture faisant face à la semelle de la tige de couche fonctionnelle (13) est fermée au moyen d'une pièce de fermeture (21) qui est cousue au bord de cette ouverture (23) et qui s'étend parallèlement à la semelle intérieure (15),
 - caractérisée en ce que**
 - la zone d'extrémité faisant face à la semelle à la fois de la tige de matière supérieure (11) et de

la tige de couche fonctionnelle (13) est retournée autour du bord circonférentiel de la semelle intérieure (15) entre la semelle intérieure (15) et la semelle extérieure (29);

la zone d'extrémité faisant face à la semelle (27) de la tige de matière supérieure (11) est raccordée dans la forme d'une surépaisseur permanente (27);

la pièce de fermeture (21) s'étend sous la semelle intérieure (15),

et un matériau d'étanchéité imperméable à l'eau est disposé entre la pièce de fermeture (21) et la surépaisseur permanente (27) de la tige de matière supérieure (11), lequel étanchéifie la pièce de fermeture (21) elle-même ainsi que la couture (23) entre la tige de couche fonctionnelle (13) et la pièce de fermeture (21).

2. Chaussure selon la revendication 1, dans laquelle la couche fonctionnelle est perméable à la vapeur d'eau.
3. Chaussure selon la revendication 1 ou 2, dans laquelle la tige de matière supérieure (11) est perméable à la vapeur d'eau.
4. Chaussure selon l'une quelconque des revendications 1 à 3, dans laquelle la tige de couche fonctionnelle (13) et la pièce de fermeture (21) sont cousues ensembles au moyen d'une couture Strobel (23).
5. Chaussure selon l'une quelconque des revendications 1 à 4, dans laquelle il est fourni un matériau d'étanchéité semblable à un adhésif (25).
6. Chaussure selon l'une quelconque des revendications 1 à 4, dans laquelle il est fourni un matériau d'étanchéité en forme de film ou de plaque.
7. Chaussure selon l'une quelconque des revendications 1 à 6, dans laquelle la pièce de fermeture (21) est constituée d'un matériau électroconducteur.
8. Chaussure selon la revendication 7, dans laquelle la couture (23) connectant la tige de couche fonctionnelle (13) et la pièce de fermeture (21) est cousue avec un matériau de couture électroconducteur.
9. Chaussure selon l'une quelconque des revendications 1 à 8, dans laquelle une semelle extérieure (29) est montée sur la surépaisseur permanente (27) de la tige de matière supérieure (11) et du matériau d'étanchéité (25).
10. Chaussure selon la revendication 9, dans laquelle la semelle extérieure (29) est montée sur la chaussure par moulage par injection.

11. Chaussure selon la revendication 9, dans laquelle la semelle extérieure (29) est fixée de manière adhésive.

12. Chaussure selon l'une quelconque des revendications 1 à 11, dans laquelle la couche fonctionnelle est constituée de PTFE microporeux expansé.

5

10

15

20

25

30

35

40

45

50

55

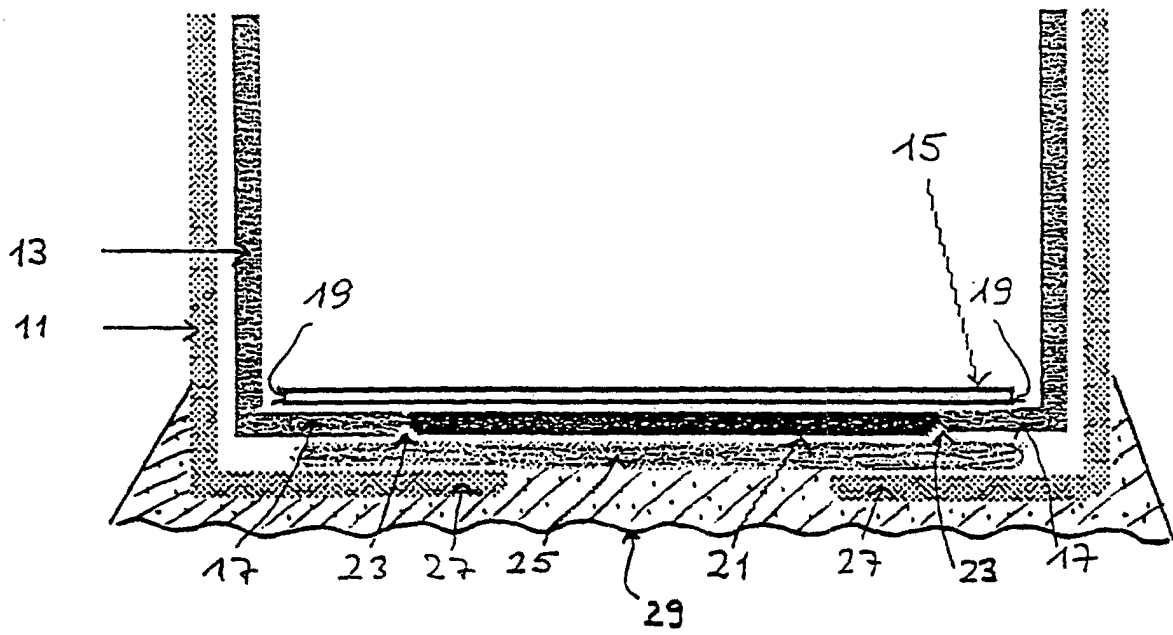

Figure 1

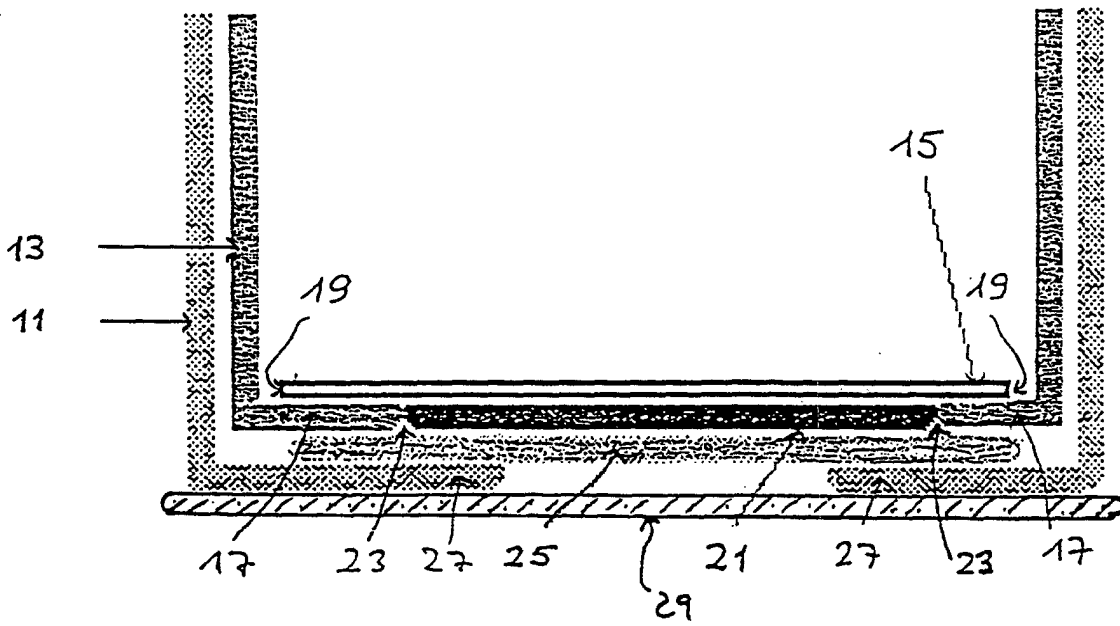

Figure 2