



(12) **EUROPEAN PATENT APPLICATION**

(88) Date of publication A3:
12.04.2000 Bulletin 2000/15

(51) Int. Cl.⁷: **B41J 3/407**

(43) Date of publication A2:
26.05.1999 Bulletin 1999/21

(21) Application number: **98121984.3**

(22) Date of filing: **19.11.1998**

(84) Designated Contracting States:
**AT BE CH CY DE DK ES FI FR GB GR IE IT LI LU
MC NL PT SE**
Designated Extension States:
AL LT LV MK RO SI

(72) Inventor:
**Yamaguchi, Koshiro
c/o BROTHER KOGYO K. K.
Nagoya-shi, Aichi 467-8561 (JP)**

(30) Priority: **20.11.1997 JP 31974097**

(74) Representative:
**Prüfer, Lutz H., Dipl.-Phys. et al
PRÜFER & PARTNER GbR,
Patentanwälte,
Harthausen Strasse 25d
81545 München (DE)**

(71) Applicant:
**BROTHER KOGYO KABUSHIKI KAISHA
Nagoya-shi, Aichi-ken 467-8561 (JP)**

(54) **Recording medium cassette**

(57) A tape cassette 8 is removably mounted in a tape printing apparatus. In the tape printing apparatus, a carriage CA mounts a thermal head HD on which heating elements are arranged in a line corresponding to the width in a main scanning direction of a tape TP.

The carriage CA can be moved in a sub-scanning direction perpendicular to the direction of arrangement of the heating elements within an open part 8e of the tape cassette 8.

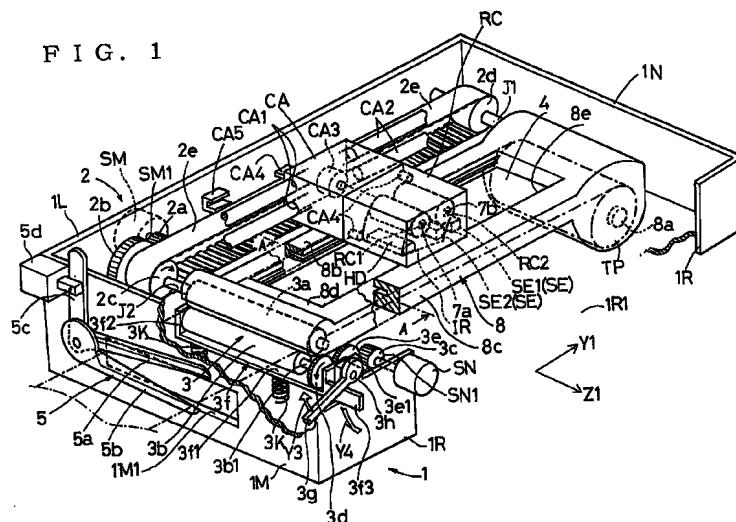

European Patent
Office

EUROPEAN SEARCH REPORT

Application Number
EP 98 12 1984

DOCUMENTS CONSIDERED TO BE RELEVANT			
Category	Citation of document with indication, where appropriate, of relevant passages	Relevant to claim	CLASSIFICATION OF THE APPLICATION (Int.Cl.6)
A	GB 2 311 039 A (ESSELTE NV) 17 September 1997 (1997-09-17) * page 16, last paragraph * * page 23, last paragraph - page 24, paragraph 1 * * page 29, paragraph 2 - page 30, paragraph 2 * * figure 3 *	1-10	B41J3/407 B41J15/04
A	EP 0 451 830 A (SEIKO EPSON CORP) 16 October 1991 (1991-10-16) * column 2, line 49 - column 3, line 19 * * column 3, line 44 - column 4, line 10 * * column 5, line 44 - column 6, line 30 * * column 10, line 10 - line 41 * * figures 1,3 *	1,2,4,5, 9,10	
P,A	EP 0 872 352 A (BROTHER IND LTD) 21 October 1998 (1998-10-21) * column 5, line 56 - column 6, line 43 * * column 7, line 16 - line 46 * * column 8, line 29 - line 51 * * claims 1-4,8; figures 1,14 *	1-10	TECHNICAL FIELDS SEARCHED (Int.Cl.6) B41J
The present search report has been drawn up for all claims			
Place of search THE HAGUE		Date of completion of the search 17 February 2000	Examiner Papastefanou, E
CATEGORY OF CITED DOCUMENTS X : particularly relevant if taken alone Y : particularly relevant if combined with another document of the same category A : technological background O : non-written disclosure P : intermediate document		T : theory or principle underlying the invention E : earlier patent document, but published on, or after the filing date D : document cited in the application L : document cited for other reasons & : member of the same patent family, corresponding document	

EPO FORM 1603 03.82 (P04C01)

**ANNEX TO THE EUROPEAN SEARCH REPORT
ON EUROPEAN PATENT APPLICATION NO.**

EP 98 12 1984

This annex lists the patent family members relating to the patent documents cited in the above-mentioned European search report. The members are as contained in the European Patent Office EDP file on
The European Patent Office is in no way liable for these particulars which are merely given for the purpose of information.

17-02-2000

Patent document cited in search report	Publication date	Patent family member(s)	Publication date
GB 2311039 A	17-09-1997	AU 2102597 A	01-10-1997
		EP 0891259 A	20-01-1999
		WO 9733755 A	18-09-1997
		US 5980140 A	09-11-1999
EP 0451830 A	16-10-1991	JP 3293185 A	24-12-1991
		JP 4005059 A	09-01-1992
		JP 4014465 A	20-01-1992
		DE 69111284 D	24-08-1995
		DE 69111284 T	08-02-1996
		US 5183333 A	02-02-1993
EP 0872352 A	21-10-1998	JP 10291707 A	04-11-1998
		EP 0872353 A	21-10-1998
		US 5943085 A	24-08-1999

EPO FORM P0459

For more details about this annex : see Official Journal of the European Patent Office, No. 12/82