



(12) **EUROPEAN PATENT APPLICATION**

(43) Date of publication:
 07.07.1999 Bulletin 1999/27

(51) Int. Cl.⁶: **A43B 23/07**

(21) Application number: **97830737.9**

(22) Date of filing: **31.12.1997**

(84) Designated Contracting States:
**AT BE CH DE DK ES FI FR GB GR IE IT LI LU MC
 NL PT SE**
 Designated Extension States:
AL LT LV MK RO SI

(72) Inventors:
 • Garbujo, Plinio
 31044 Montebelluna (Treviso) (IT)
 • Poloniato, Paolo
 31031 Caerano di Sanmarco (Treviso) (IT)

(71) Applicants:
 • W.L. GORE & ASSOCIATI S.r.l.
 37010 Cavaion Veronese (VR) (IT)
 • DOLOMITE S.P.A.
 I-31044 Montebelluna (Treviso) (IT)

(74) Representative:
 Hirsch, Peter et al
 Klunker Schmitt-Nilson Hirsch
 Winzererstrasse 106
 80797 München (DE)

(54) **Footwear liner**

(57) A footwear liner (19) for lining a footwear having an upper material shaft, the liner (19) being adapted to line an inside of at least the upper material shaft and may comprise a waterproof functional layer (21),

wherein a tongue (17) is mounted to be at the inside of the liner (19).

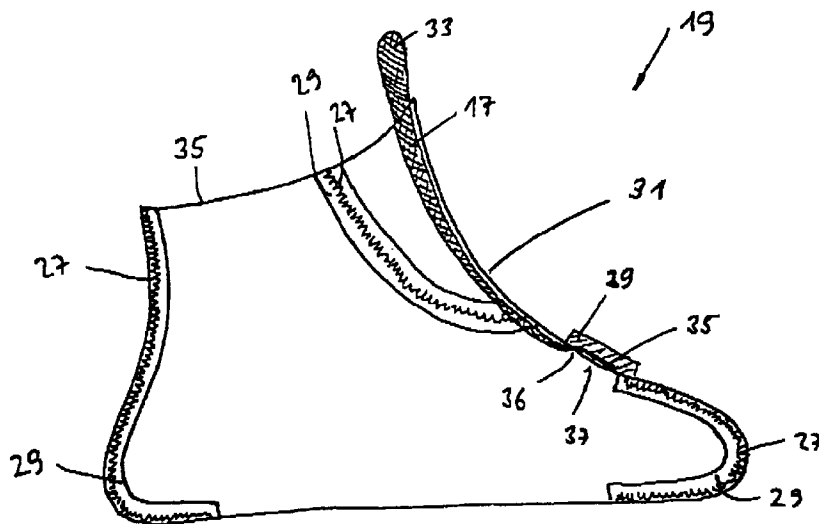

FIG. 1

Description

[0001] The invention relates to a footwear liner for lining a footwear having an upper material shaft. The liner is arranged inside of at least the upper material shaft.

[0002] Further, the invention relates to a method of making a footwear liner and to a footwear comprising a footwear liner.

[0003] Conventional footwear is usually provided with a tongue integrated with or fixed to the upper material shaft.

[0004] High performance hiking boots are constructed with upper material which must be relatively stiff and structured in order to provide a good physical support to the foot. It is known to provide this type of hiking boots with a double tongue. A first tongue is formed of the upper material and is correspondingly stiff. A second tongue is sewn to the inside of the upper material and extends over the free end of the first tongue. The second tongue is normally padded with foam or other suitable padding materials. The purpose of the second tongue is to prevent the stiff first tongue from pressing against the foot of the person wearing the footwear, in particular at the upper end of the first tongue and at its side portions where the tongue tends to wrinkle when the footwear is tightly closed by means of the laces thereof.

[0005] The object of the present invention is to provide means for making double tongue footwear in an easy and low-cost way.

[0006] To solve this object, the invention provides for a footwear liner for lining a footwear having an upper material shaft, wherein the liner is arranged inside of at least the upper material shaft and wherein a tongue is mounted to be at the inside of the liner.

[0007] The liner may comprise a waterproof functional layer. The functional layer may in addition to being waterproof also be water vapor permeable. Such functional layers are used to make footwear which is waterproof and possibly water vapor permeable. Footwear of this type may be lined with a sock-like insert consisting of or comprising the functional layer material (also known by the technical expression "bootie") to protect the foot fully from penetrating water, or a construction is used wherein the upper material shaft only is lined with a functional layer shaft, wherein the sole-facing end areas of both the upper material shaft and of the functional layer shaft are turned around the circumferential edge of an insole. The sole-facing open end of both the upper material shaft and the functional layer shaft are lasted and glued around a last holding the insole in an adhesive lasting process. The lower end of the upper material shaft may be replaced by a porous material such as a net. The outer sole may be glued or molded on.

[0008] The tongue may be arranged in a floating manner, this means only a lower end of the tongue is fixed to the liner whereas the upper part of the tongue is free to

move relative to the liner. The neck portion of the liner can be fixed to the neck portion of the upper material shaft.

[0009] When the footwear liner containing the tongue is arranged inside of the upper material shaft which also contains a tongue, the tongue attached to the liner acts as a second or inner tongue in the total footwear construction with the tongue of the upper material shaft being a first or outer tongue.

[0010] The mounting of this second tongue at the footwear liner instead of the upper material shaft is highly advantageous in that it is much easier to fix a second tongue to a footwear liner than to an upper material shaft.

[0011] Further, in waterproof footwear comprising a functional layer, if the mounting of the tongue to the footwear liner is done by sewing, it is easy to seal the seam by means of a sealing tape.

[0012] The stitching holes penetrating the functional layer need to be sealed by sealing tape. In case the second tongue were sewn to the upper material shaft after a functional layer liner is already arranged within the upper material shaft, it would not be possible anymore to seal the seam by means of sealing tape in order to "cure" the functional layer penetrated by the stitching holes and the sewing thread. The functional layer of the liner is usually laminated between a lining layer and a backing material layer so that the functional layer is not directly accessible to sealing tape. The lining layer may comprise any combination of a foam, woven or non-woven or knitted textile or a fleece, made from for example polyester, polyamide, wool, polyurethane or polyacrylate. The sealing tape does not adhere to the lining layer, at least not to such an extent that the functional layer itself can be sealed. In contrast, sealing tape adheres well to the backing material layer. Usual backing material layers are very thin textile layers, for example a polyamide woven textile, which allow intimate sealing contact between the functional layer itself and the sealing tape. The sealing tape itself may be made up of a functional layer with a textile knit on one side and an adhesive, for example polyurethane, on the other side, i.e. on that side adhering to the seam. The lining layer is arranged on the inside of the footwear liner to form a padding and to absorb sweat and to allow it to be transported away from the foot. The backing layer is arranged on the outside of the footwear liner to provide mechanical protection for the functional layer. It is therefore possible to seal the stitching seam without any problems by attaching the sealing tape to the sealable outside of the footwear liner before arranging it within the upper material shaft.

[0013] The inner side is defined to be the side facing the foot whereas the outer side is the side facing away from the foot.

[0014] The tongue can be padded, e.g. with foam, wad, fleece, textile, gel, liquid, air or any other suitable padding materials.

[0015] In a preferred embodiment of the invention, a free end portion of the tongue attached to the footwear liner and extending beyond a neck opening of the footwear liner is provided with engaging means, e.g. in the form of a zipper, velcro-type closure, snap fasteners, buttons or strings, which cooperatively engage with a complementary engaging means provided on the inside of a free end portion of the outer tongue and/or the upper material when the footwear liner is arranged within the upper material shaft. After engagement between the engaging means of the inner tongue and the complementary engaging means of the outer tongue, both tongues behave and can be handled like one tongue.

[0016] An end portion of the tongue of the footwear liner being opposed to the free end portion thereof can be used as a fixing end portion of the tongue for fixing the tongue to the footwear liner, either by means of stitching or by other fixing means, e.g. gluing. Alternately, the fixing end portion of the tongue can be formed by means of a flap fixed to the fixing end of the tongue, on the one hand, and fixed to the footwear liner, e.g. by means of stitching, on the other hand.

[0017] It is not absolutely necessary to fix the tongue permanently to the footwear liner. The fixing end portion can be detachably fixed to the liner as well.

[0018] The fixing end portion of the tongue can be stitched to the inner side or the outer side of the footwear liner. Preferably the seam is not in the form of a single line but rather e.g. in the form of a cross covering an area large enough to prevent tearing of the functional layer. If the tongue is stitched to the outside of the liner, the footwear liner is provided with an opening for feeding the fixing end portion of the tongue from the inside of the footwear liner to the outside thereof before stitching the fixing end portion on the outside of the footwear liner. In any case, the stitching seam is sealed by means of sealing tape placed on the outside of the footwear liner.

[0019] The footwear liner, according to the present invention, provided with the tongue, can have the shape of a sock-like insert or bootie or it can have the form of a liner shaft to be arranged inside of the upper material shaft, with the sole-facing end area of the liner shaft being turned around the circumferential edge of an insole of the footwear in the form of a lasting allowance which is fixed to the insole, e.g. in an adhesive lasting process. Another possibility is to fix the sole-facing open end of the liner shaft to the insole by means of stitching, e.g. in the form of a Strobel seam.

[0020] According to a preferred embodiment of the invention the functional layer, in addition to being waterproof, is also water vapor permeable. A footwear liner comprising a functional layer of this type should be used for footwear the upper material of which is vapor permeable as well which allows comfortable breathable waterproof footwear to be produced.

[0021] The functional layer material may be made of

any waterproof material or film, but is preferably microporous expanded PTFE, with a continuous liquid water impermeable coating. Materials suitable for the functional layer comprise microporous expanded polytetrafluoroethylene (PTFE) as described in US patent specifications 3,953,566 and 4,187,390; expanded PTFE provided with water vapour permeable impregnating agents and/or layers as described in US patent specification 4,194,041; water vapour permeable polyurethane layers; or elastomers, such as copolyether-ester and laminates thereof as described in US patent specifications 4,725,481 and 4,493,870.

[0022] "Waterproof footwear" is defined to mean that no liquid water leaks through the footwear, with no pressure being applied.

[0023] The Two Hour Test is used to test for waterproofness in footwear. This test was performed at ambient temperature and humidity. The footwear was checked to make sure that it was completely dry. A paper towel was folded in half, lengthwise, so that it was double, i.e., had two layers, and was set on a clean benchtop. The paper towel functions as a blotter. The footwear was then set on this paper towel blotter. Approximately 500-600 ml of clean, tap water was poured into the footwear, filling it to the top of the heel. The volume of water will vary with the size of the footwear. The paper towel blotter was then observed for wet spots, at fifteen minute intervals during a two hour period. The footwear was rated to Pass, if the paper towel blotter remained dry, i.e., no water leaked through the footwear. The footwear was rated to Fail, if there were wet spots on the paper towel blotter, indicating where water had seeped through the footwear and collected on the paper towel.

[0024] "Waterproof functional layer" as used herein is meant a functional layer having water-penetration-resistance (hydrostatic resistance) of 6.8 kPa (1.0 psi) or more.

[0025] The Low Pressure Hydrostatic Resistance Test (WEP) is used to indicate the waterproofness of the functional layer. It consists essentially of forcing water against one side of a test piece, and observing the other side of the test piece for indications of water penetration through it. The test specimen was clamped and sealed between rubber gaskets in a fixture that holds the test piece. One surface of the test specimen was in contact with the water and the other side faced upward, open to the atmosphere, for close observation. Air was removed from inside the fixture and pressure was applied to the inside surface of the test piece, over an area of 7.62 cm (3.0 inches) diameter, as water was forced against it. The water pressure on the test piece was increased to about 6.9 kPa (1.0 psi) by a pump connected to a water reservoir, as indicated by an appropriate gauge and regulated by an in-line valve. The surface of the test piece was watched closely for the appearance of any water forced through the material. Water seen on the surface is interpreted as a leak. The sample surface is observed

for one minute at test pressure, at which time the number of leaks are counted and recorded.

[0026] Water-vapor-permeable as used herein is meant having a water-vapor-transmission (WVTR) rate of 100 g/m²/24-hours or more.

[0027] A description of the test employed to measure water vapor transmission rate (WVTR) is given below.

[0028] In the procedure, approximately 70 ml of a solution consisting of 35 parts by weight of potassium acetate and 15 parts by weight of distilled water was placed into a 133 ml. polypropylene cup, having an inside diameter of 6.5 cm at its mouth. An expanded polytetrafluoroethylene (PTFE) membrane having a minimum WVTR of approximately 85,000 g/m²/24 hrs as tested by the method described in U.S. Patent 4,862,730 to Crosby and available from W. L. Gore & Associates, Inc. of Newark, Delaware, was heat sealed to the lip of the cup to create a taut, leakproof, microporous barrier containing the solution.

[0029] A similar expanded PTFE membrane was mounted to the surface of a water bath. The water bath assembly was controlled at 23C plus 0.2C, utilizing a temperature controlled room and a water circulating bath. The sample to be tested was allowed to condition at a temperature of 23C and a relative humidity of 50% prior to performing the test procedure. Samples were placed so the microporous polymeric membrane was in contact with the expanded polytetrafluoroethylene membrane mounted to the surface of the water bath and allowed to equilibrate for at least 15 minutes prior to the introduction of the cup assembly.

[0030] The cup assembly was weighed to the nearest 1/1000g and was placed in an inverted manner onto the center of the test sample.

[0031] Water transport was provided by the driving force between the water in the water bath and the saturated salt solution providing water flux by diffusion in that direction. The sample was tested for 60 minutes and the cup assembly was then removed, weighed again within 1/1000g.

[0032] The WVTR of the sample was calculated from the weight gain of the cup assembly and was expressed in grams of water per square meter of sample surface area per 24 hours.

[0033] The footwear liner of the present invention can be made by first forming a liner bootie or liner shaft and than fixing a tongue to the liner in such a way that the entire tongue or at least a floating main part of the tongue is inside of the liner.

[0034] According to an embodiment of the invention, after making the liner it is turned inside out, the tongue is stitched on the turned out inside of the liner, the liner is turned outside in and the stitching seam is sealed by sealing tape adhesively fixed to the outside of the liner.

[0035] The invention further provides footwear comprising an upper material shaft having a first tongue and a footwear liner of the present invention having a tongue.

[0036] Further embodiments of the footwear liner and of the method for making it are stated in the dependent claims.

[0037] In the following, the invention will be explained in more detail with reference to embodiments which are schematically shown in the attached figures.

Figure 1 is a schematic view of a first embodiment of a footwear liner of the invention;

Figure 2 is a schematic view of a second embodiment of a footwear liner of the invention;

Figure 3 is a schematic view of a third embodiment of a footwear liner of the invention;

Figure 4 shows schematically a sequence of manufacturing phases A to F for making the embodiment shown in Figure 2; and

Figure 5 is a schematic presentation of a section of a functional layer laminate with a seam and a sealing tape.

[0038] Figures 1 and 2 show schematically first and second embodiments of the invention in the form of bootie-shaped footwear liners 19. Footwear liner 19 can be constructed with a three-layer laminate as schematically shown in Figure 5, comprising a functional layer 21 which is sandwiched between a backing layer 23, for example a polyamide woven textile, on an outside and a lining layer 25, for example a polyacrylate woven textile and a polyurethane foam, on an inside. The bootie consists of a number of laminate pieces which are connected to form the bootie by means of bootie seams 27. Each bootie seam 27 is sealed by means of sealing tape 29 as it is well known in this art. Inside of an instep portion 31 of the bootie 19 there is arranged a padded tongue 17. A free end portion 33 of tongue 17 projects over a neck opening 35 of bootie 19. The opposed end of tongue 17 is provided with a fixing end portion 35 through which tongue 17 is fixed to bootie 19. The fixing end portion 35 can be a part of the tongue 17 or it can be a flap fixed to tongue 17. Besides the fixing end portion 35, tongue 17 is floating or movable within bootie 19 so that it can be bent away from the instep portion 31 of bootie 19, e.g. when the neck portion of bootie 19 is to be attached to the inside of the neck portion of the upper material shaft, e.g. by sewing.

[0039] In the embodiment shown in Figure 1, fixing end portion 35 of tongue 17 is led through an opening 36 of the liner laminate such that the entire fixing end portion 35 or at least a substantial part thereof is positioned outside of the liner laminate. Fixing end portion 35 is stitched to the liner laminate by means of a seam 37 which is sealed by means of sealing tape 39 adhesively fixed to the outside of the liner laminate such that it sealingly covers seam 37 as well as opening 36.

[0040] The seam portion of bootie 19 is schematically shown in more detail in Figure 5. Lining layer 25 consists of a material and has a thickness which does not allow sealing of seam 37 by means of a sealing tape on the free surface of lining layer 25. The textile backup layer 23 however consists of a material and has a thickness such that sealing tape 29 can be adhesively attached thereto in a way that it securely seals functional layer 21 where it is water permeable due to the stitching holes and the stitching thread. Sealing tape 39 is dimensioned so that it seals not only seam 37 but opening 36 as well.

[0041] Figure 2 shows an embodiment of a bootie of the invention which differs from the embodiment in Figure 1 only in that its entire fixing end portion 35 is positioned inside of the liner laminate so that there is no need of an opening like opening 36 in Figure 1.

[0042] Figure 3 shows schematically a footwear liner 41 in the form of a liner shaft a sole-facing end 43 of which is open and will be fixed, e.g. by sewing, to an insole of a footwear within the upper material shaft of which footwear liner 41 is to be arranged.

[0043] As with bootie 19 shown in Figure 1, the fixing end portion 35 of tongue 17 of Figure 3 is fixed to the outside of the liner laminate.

[0044] At the outside of the free end portion 33 of tongue 17, there is attached a velcro closure 45, by means of which tongue 17 can be detachably fixed to a complementary velcro closure provided at a corresponding position of the inside of an outer tongue of an upper material shaft within which the footwear liner 41 of Figure 3 is to be arranged.

[0045] The bootie-shaped footwear liners 19 of Figures 1 und 2 can be provided with a velcro closure as well.

[0046] A preferred method of making a bootie-shaped footwear liner according to Figure 2 is shown in Figure 4 illustrating a sequence of manufacturing phases A to F.

[0047] Figure 4A shows a bootie-shaped footwear liner or bootie 19 after it has been formed from a number of laminate pieces by sewing and tape sealing. Backing layer 23 as shown in Figure 5 forms the outside of bootie 19 as shown in Figure 4A.

[0048] Bootie 19 is then turned inside out such that lining layer 25 of the turned out bootie is at the outside thereof (Figure 4B). Then tongue 17 is positioned on the instep portion 31 of the turned bootie 19 (Figure 4C) and the fixing end portion 35 of tongue 17 is fixed to the turned bootie by seam 37 (Figure 4D). Bootie 19, together with tongue 17 stitched thereon, is turned again by turning the bootie outside in so that backing layer 23 again is on the outside of bootie 19 and lining layer 25 is at the inside thereof (Figure 4E). Thereafter, sealing tape 29 is adhesively attached to the outside of the bootie laminate so that sealing tape 29 sealingly covers seam 37 (Figure 4F).

[0049] A footwear liner bootie 19 according to Figure 1 or 3 or a footwear liner shaft 41 according to Figure 3

is then ready for being arranged inside an upper material shaft of the footwear to be made waterproof by means of bootie 19 or liner shaft 41. After fixing bootie 19 or liner shaft 41 at the inside of an upper material shaft, tongue 17 protects the foot of a person wearing this type of footwear from pressure caused by the stiff and possibly wrinkled outer tongue 15 of the upper material shaft.

[0050] The result is footwear with a high wearing comfort.

Claims

1. A footwear liner (19, 41) for lining a footwear having an upper material shaft,
 - the liner (19, 41) being adapted to line an inside of at least the upper material shaft, wherein a tongue (17) is mounted to be at the inside of the liner (19, 41).
2. A footwear liner of claim 1 comprising a waterproof functional layer (21).
3. A footwear liner of claim 1 or 2, wherein the tongue (17) is a floating tongue.
4. A footwear liner of one of claims 1 to 3, wherein the tongue (17) is padded.
5. A footwear liner of claim 4, wherein the tongue (17) is padded with material selected from a group comprising foam, wad, vleece, textile, gel, liquid or air.
6. A footwear liner of one of claims 1 to 5, wherein the tongue (17) has a free end portion (33) projecting over a neck opening of the liner (19, 41).
7. A footwear liner of one of claims 1 to 6, wherein the tongue (17) has a fixing end portion (35) being opposed to the free end portion (33) and being fixed to the liner (19, 41).
8. A footwear liner of claim 7, wherein the fixing end portion (35) is permanently fixed to the liner (19, 41) by means of an adhesive.
9. A footwear liner of claim 7, wherein the fixing end portion (35) is permanently fixed to the liner (17, 41) by means of at least one seam (37).
10. A footwear liner of claim 9, wherein the at least one seam (37) is sealed by means of a sealing tape (29) fixed to the liner (19, 41).
11. A footwear liner of one of claims 1 to 10, wherein the liner (19, 41) comprises a laminate (21, 23, 25) consisting of the functional layer (21) and at least a

backing material layer provided on the outside of the functional layer (21).

12. A footwear liner of one of claims 1 to 11, wherein the functional layer (21) consists of expanded, microporous PTFE. 5
13. A footwear liner of one of claims 7 to 12, wherein the fixing end portion (35) is detachably fixed to the liner (19, 41) by fixing means selected from the group of zippers, velcro-type closures, snap fasteners, buttons and strings. 10
14. A footwear liner of one of claims 7 to 12, wherein the fixing end portion (35) is fixed at the inside of the liner (19, 41). 15
15. A footwear liner of one of claims 7 to 12, wherein a portion of the liner (19, 41) adjacent to the fixing end portion (35) of the tongue (17) is provided with an opening (36) via which the fixing end portion (35) passes from the inside to the outside of the liner (19, 41) and wherein the fixing end portion (35) is fixed to the outside of the liner (19, 41). 20
16. A footwear liner of one of claims 1 to 15, having the shape of a bootie (19) for lining the inside of the upper material shaft as well as an inside of a sole structure of the footwear. 25
17. A footwear liner of one of claims 1 to 15, having the shape of a shaft (41) for lining the inside of the upper material shaft of the footwear only. 30
18. A method for making a footwear liner (19, 41) for lining footwear having an upper material shaft, comprising the steps of: 35
- forming a liner (19, 41) to be adapted to the inner shape of at least the upper material shaft, and 40
- mounting a tongue (17) to be at the inside of the liner (19, 41).
19. A method of claim 18, wherein the tongue (17) is sewn to the liner (19, 41) and the seam (37) is sealed by means of a sealing tape (29). 45
20. A method of claim 19, wherein the liner (19, 41) is made from a laminate (21, 23, 25) consisting of a functional layer (21), a lining layer (25) on one side of the functional layer (21), and a backing material layer (23) on the other side of the functional layer (21), and wherein the sealing tape (29) is attached to the backing material layer (23) of the laminate. 50
21. A method of claim 20, comprising the steps of: forming the liner (19, 41); 55

turning the liner (19, 41) inside out;
sewing the tongue (17) to the turned out inside of the liner (19, 41);
turning the liner (19, 41) outside in; and
sealing the seam (37) by the tape (29).

22. Footwear comprising

an upper material shaft being provided with an outer tongue; and
a footwear liner (19, 41) of one of claims 1 to 17.

23. Footwear of claim 22, wherein the tongue (17) has a free end portion (33) projecting over a neck opening of the liner (19, 41) and wherein the outside of the free end portion (33) is provided with engaging means (45) for cooperatively engaging with a complementary engaging means provided on the inside of the outer tongue.

24. Footwear liner of claim 23, wherein the engaging means (45) and the complementary engaging means are selected from a group comprising zippers, velcro-type closures, snap fasteners, buttons and strings.

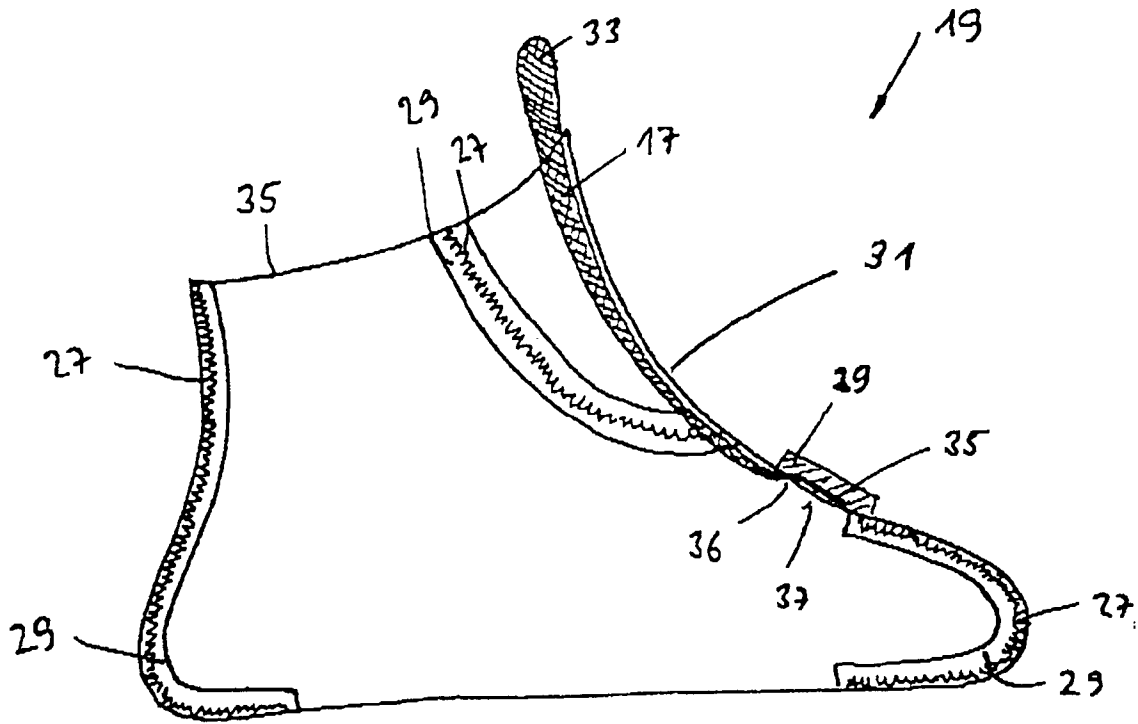

FIG. 1

FIG. 2

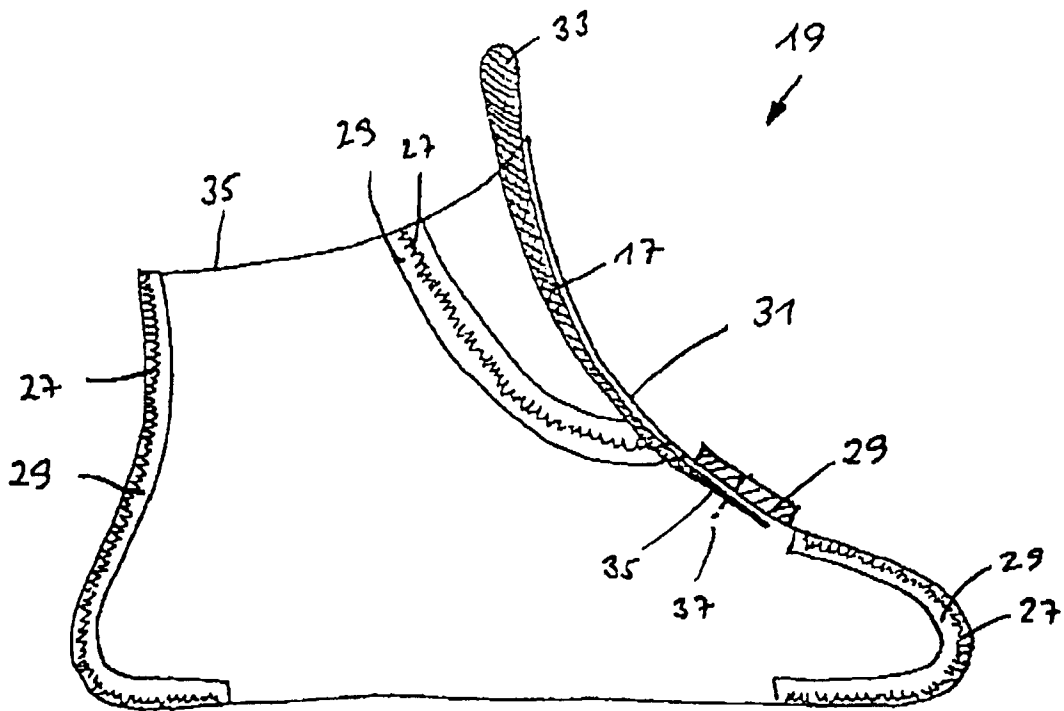

FIG. 3

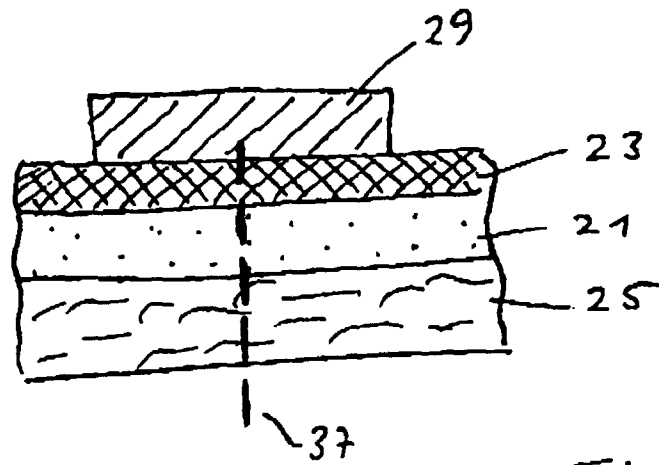
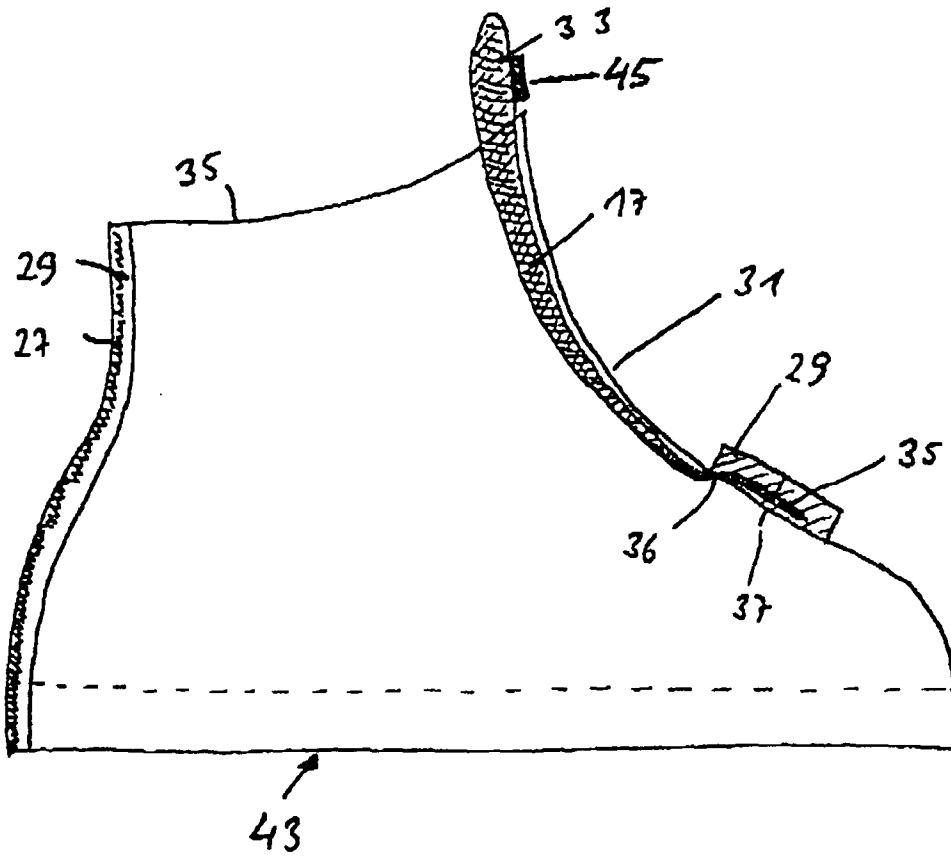
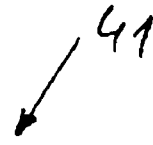

FIG. 5

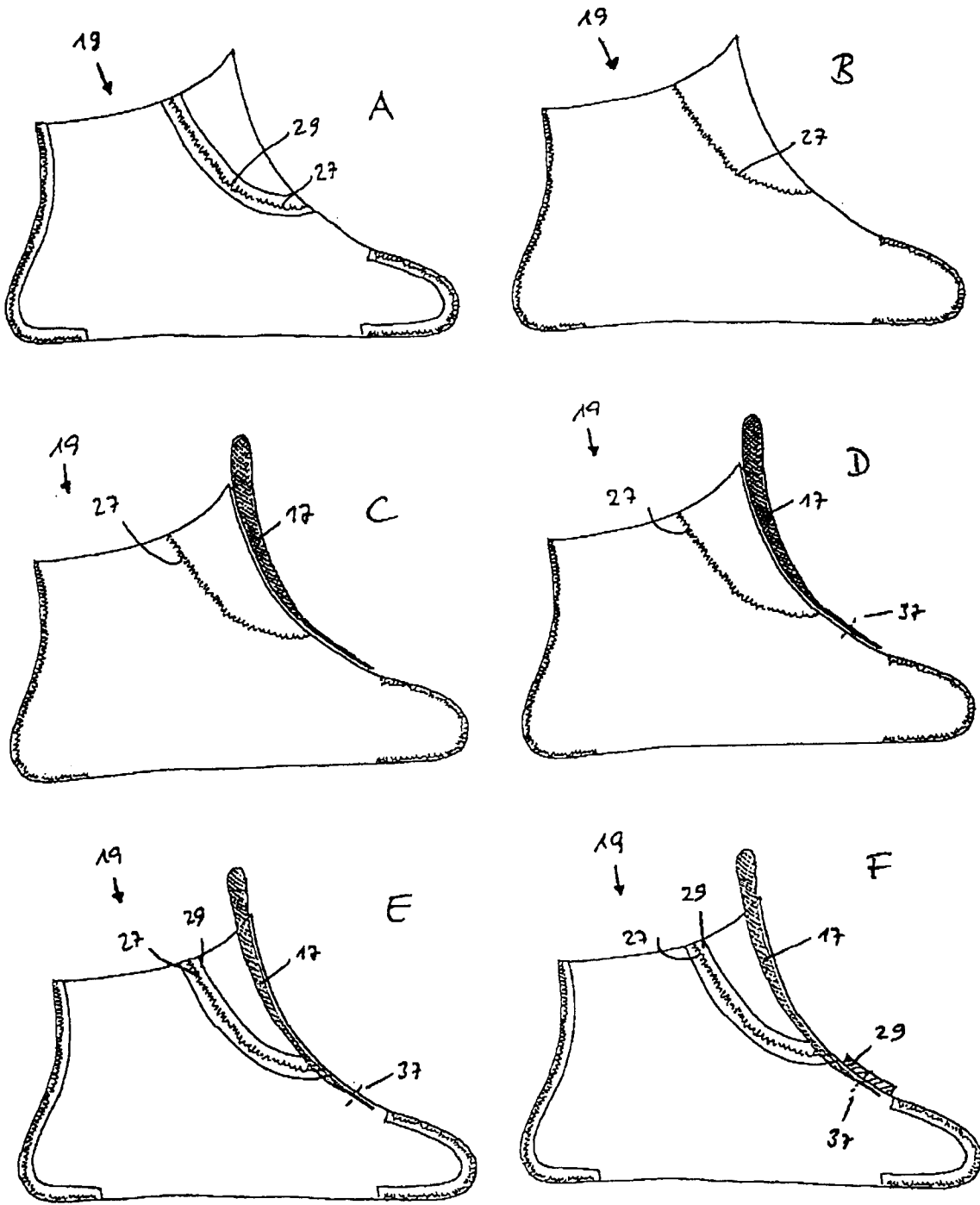

FIG. 4

