



Europäisches Patentamt
European Patent Office
Office européen des brevets



(11) **EP 0 933 740 B1**

(12) **EUROPEAN PATENT SPECIFICATION**

(45) Date of publication and mention
of the grant of the patent:
19.10.2005 Bulletin 2005/42

(51) Int Cl.7: **G08B 13/24**

(21) Application number: **99101906.8**

(22) Date of filing: **29.01.1999**

(54) **Radio wave type burglar detection apparatus**

HF-Antidiebstahlvorrichtung

Dispositif antivol à radiofréquence

(84) Designated Contracting States:
DE FR GB

(30) Priority: **30.01.1998 JP 1889598**

(43) Date of publication of application:
04.08.1999 Bulletin 1999/31

(73) Proprietor: **MITSUBISHI MATERIALS
CORPORATION**
Chiyoda-ku, Tokyo (JP)

(72) Inventors:

- **Mori, Tomohiro c/oMitsubishi Materials Co.
Omiya-shi, Saitama-ken (JP)**
- **Endo, Takanori c/oMitsubishi Materials Co.
Omiya-shi, Saitama-ken (JP)**
- **Ishiyama, Kouichi c/oMitsubishi Materials Co.
Omiya-shi, Saitama-ken (JP)**

- **Yonezawa, Tadashi c/oMitsubishi Materials Co.
Omiya-shi, Saitama-ken (JP)**
- **Miyake, Masami c/oMitsubishi Materials Co.
Omiya-shi, Saitama-ken (JP)**
- **Osawa, Shigeyuki
Noda-shi, Chiba-ken (JP)**
- **Yahata, Seiro c/o IP SERVICE CORPORATION
Tokyo (JP)**

(74) Representative:
**Gille Hrabal Struck Neidlein Prop Roos
Patentanwälte
Brucknerstrasse 20
40593 Düsseldorf (DE)**

(56) References cited:
GB-A- 2 230 164 US-A- 3 828 341
US-A- 3 938 044 US-A- 5 406 262

EP 0 933 740 B1

Note: Within nine months from the publication of the mention of the grant of the European patent, any person may give notice to the European Patent Office of opposition to the European patent granted. Notice of opposition shall be filed in a written reasoned statement. It shall not be deemed to have been filed until the opposition fee has been paid. (Art. 99(1) European Patent Convention).

Description

[0001] The present invention relates to a radio wave type burglar detection apparatus having the features of the preamble of claim 1.

[0002] Heretofore, a burglar-alarm tag is disclosed in JP-A- 8-185584, the tag which is constructed such that a resonance circuit block of the tag attached to an object for monitoring a burglar resonates with a specific frequency from a radio wave transmission unit, separation detection means detects whether the tag is separated from the object for monitoring a burglar, and a separation information block controls warning sound outputs means on the basis of a detection output of this separation detection means. In this burglar-alarm tag, the resonance circuit block is constructed with forming conductive metal foil, having a predetermined shape, by etching and the like in both sides of a thin film of an insulating dielectric. For example, a coil portion formed in a spiral shape with conductive metal foil, and a surface-side planer pattern of a capacitor, connected to the coil portion, in the central portion of the spiral of this coil portion are formed on the surface of the thin film.

[0003] In an entrance of an outlet selling the object for monitoring a burglar, a transmission antenna and a reception antenna are installed in a predetermined interval, and these antennas are electrically connected to a control block. The control block is constructed such that the control block makes the transmission antenna transmit a radio wave having a frequency resonating in the resonance circuit block and always checks a signal level of a signal received from the reception antenna. Furthermore, a speaker sounding an alarm is connected to a control output terminal of the control block.

[0004] With using a burglar-alarm tag constructed in this manner, a radio wave transmitted from a transmission antenna resonates in a resonance circuit block of the tag attached to an object for monitoring a burglar if an object for monitoring a burglar passes between the transmission antenna and a reception antenna without payment. Hence, the reception antenna receives an input signal whose reception level is modulated. In consequence, the control block sounds an alarm from a speaker and can check takeout of an unpaid product. In regard to a paid-up product, a tag is disabled by breaking a capacitor through applying a strong radio wave, or an alarm is disabled by temporarily stopping the alarm speaker.

[0005] Nevertheless, the above burglar-alarm tag requires a transmission antenna and a reception antenna, which are comparatively large, so as to detect a burglar of a product with the tag. Therefore, this type of tag has a defect that a comparatively wide space is required as an installation space of these antennas.

[0006] In addition, the above burglar-alarm tag has a possibility of a malfunction in a location with plenty of electrical noise of a computer and the like

[0007] Furthermore, in regard to the above burglar-

alarm tag, a central line of the helical coil portion extends in the direction orthogonal to a mounting surface of an object, and hence a radio wave transmitted from the resonance circuit block passes the object. Therefore, if this tag is attached on an object whose surface is made of conductive material such as aluminum or ferromagnetic material such as a steel sheet, self inductance of the coil portion changes. Hence, in comparison with a case that the tag is attached to an object whose surface is made of insulating-material or non-magnetic material, the tag has a possibility of not operating as a burglar-alarm tag due to an influence of a change of a resonance frequency in the resonance circuit block.

[0008] In a furthermore known electronic article surveillance system (EAS) comprising the features of the preamble of claim 1 used for detecting the position of an article within a surveillance zone a tag is attached to each article to be detected by means of a magnetic field (US-A-5 406 262). This surveillance system requires much space and a large number of tags and is not suitable to survey small space locations.

[0009] The object of the present invention is to provide a burglar detection apparatus for detecting presence and absence of an article placed at a comparatively small space such as in a cash register.

[0010] This object is solved in accordance with the present invention by an apparatus having the features of the independent claim 1.

[0011] Improvements of this apparatus and preferred embodiments thereof are subject matter of the dependent subclaims.

[0012] The apparatus of the present invention detects a burglar by detecting with using a radio wave whether a tag having a resonance circuit block is in a predetermined location and in particular detects presence and absence of a tag having a resonance circuit block placed at a comparatively small space such as a cash register of a retail store or the like.

[0013] The radio wave type burglar detection apparatus of the present invention can be installed in a comparatively small space, can prevent a malfunction even if the apparatus is installed in a location with plenty of electrical noise, and can surely detect the presence and absence of a tag even if the tag is placed in the vicinity of an object made of metal.

[0014] Another object is to provide furthermore, the radio wave type burglar detection apparatus of the present invention can increase a ratio (S/N ratio) between a signal transmitted by the tag detection sensor and a signal generated by electrical noise of a computer and the like by making a radio wave, which is transmitted by the tag detection sensor, have directivity.

[0015] Still another aspect of the present invention is a radio wave type burglar detection apparatus that can immediately detect abnormal operation caused by a failure and the like of a tag, a tag detection sensor, a drawer sensor, or an upper lid sensor, and hence can increase the reliability of the apparatus.

[0016] In the drawings, several preferred embodiments of the invention are schematically shown, wherein

Figure 1 is a block diagram showing a radio wave type burglar detection apparatus according to a first embodiment of the present invention;

Figure 2A is a vertical cross-sectional view of a safe in a state of a drawer being contained in the safe;

Figure 2B is a vertical cross-sectional view of a safe in a state of the drawer being drawn from the safe;

Figure 3 is an exploded perspective view of a tag in the radio wave type burglar detection apparatus;

Figure 4 is a vertical cross-sectional view of the tag;

Figure 5 is a block diagram of a tag detection circuit thereof;

Figure 6 is a block diagram that shows a second embodiment of the present invention and corresponds to Figure 1;

Figure 7 is a block diagram that shows a third embodiment of the present invention and corresponds to Figure 1;

Figure 8A is a vertical cross-sectional view of a safe in a state of an upper lid being closed;

Figure 8B is a vertical cross-sectional view of a safe in a state of an upper lid being opened;

Figure 9 is a block diagram that corresponds to Figure 1 and shows a radio wave type burglar detection apparatus that comprises a self operation management circuit and is a fourth embodiment, of the present invention; and

Figure 10 is a block diagram that corresponds to Figure 7 and shows a radio wave type burglar detection apparatus that comprises a self operation management circuit and is a fifth embodiment of the present invention.

[0017] A radio wave type burglar detection apparatus, as shown in Figures 1 and 3, comprises: a tag 11 having a resonance circuit block 12; a box 13 containing a drawer 14 where the tag 11 is contained with an object 15; a tag detection sensor 16 detecting whether the tag 11 is present within the drawer 14; a drawer sensor 17 detecting whether the drawer 14 is drawn; and a control circuit 19 controlling alarm means 18 on the basis of each detection output of the tag detection sensor 16 and drawer sensor 17. The tag 11 is formed in the approximately same shape as that of the object 15 in this embodiment. This tag 11, as shown in Figures 3 and 4, comprises: a base plate 11a made of insulating-material such as paper and a plastic thin sheet; a coil portion 11b that is made of conductive material such as copper and aluminum and is formed in a helical and approximately rectangular shape on the upper surface of this base plate 11a; a dielectric layer 11c that is made of insulating-material and is bonded to cover the upper surface of the base plate 11a through the coil portion 11b; and a surface layer 11d that is made of insulating-material and

is bonded to cover the upper surface of the dielectric layer 11c.

[0018] On the upper surface of the base plate 11a, a first electrode layer 11e and a first connecting terminal 11f that are made of conductive material and are electrically connected to an internal end and an external end of the coil portion 11b are bonded respectively. The dielectric layer 11c is bonded to cover a part of the upper surface of the base plate 11a except the first connecting terminal 11f. In addition, on the bottom surface of the surface layer 11d, a second electrode layer 11g and a second connecting terminal 11h that are made of conductive material and face to the first electrode layer 11e and first connecting terminal 11f are bonded respectively. The second electrode layer 11g and second connecting terminal 11h are electrically connected with each other. The first and second connecting terminals 11f and 11h are electrically connected with each other when the surface layer 11d is laminated through the dielectric layer 11c on the base plate 11a. In addition, a capacitor 11i is constructed with the first electrode layer 11e, first dielectric layer 11c, and second electrode layer 11g, and a resonance circuit block 12 is constructed with this capacitor 11i and coil portion 11b. A resonance frequency of the resonance circuit block 12 is 7-9 MHz in this embodiment.

[0019] The box 13 is a safe where the drawer 14 is contained, and the object 15 is plenty of bank notes (Figures 1 and 2). The drawer 14 is partitioned into a document container 14c, which is in a near end, and bank note containers 14d and 14e, which are in a back end, with a first partition board 14a extending in the width direction. The bank note container is partitioned into a pair of bank note containers 14d and 14e, which are partitioned into a left part and a right part, respectively, with a second partition board 14b extending in the drawing direction. This drawer 14 is made of metal material such as a steel sheet, the tags 11 and 11 are contained in the pair of bank note containers 14d and 14e, respectively, and further, on these tags 11 and 11, plenty of bank notes 15 and 15 are piled respectively. In addition, soft magnetic members 22 and 22 are sandwiched between the tags 11 and 11, and the drawer 14.

[0020] It is preferable to use a sintered ferrite, a compact of ferrite powder and binder, or composite material of soft magnetic metal powder as this soft magnetic member. As the binder, polyester, nylon, polyvinyl chloride, synthetic rubber, natural rubber, and the like can be used. In addition, as the composite material of soft magnetic metal powder, composite material of carbonyl iron powder, permalloy powder by ball mill crushing, and the like, and resin such as polyester, nylon, polyvinyl chloride, synthetic rubber, and natural rubber can be used. The purpose of inserting the soft magnetic member 22 between the tag 11 and drawer 14 is to make it possible that a magnetic field easily passes to the resonance circuit block of the tag 11 owing to the soft magnetic member 22, and hence, that the tag 11 is surely

detected by the tag detection sensor 16 even if the drawer 14 is made of metal. In addition, an opening 13a for drawing the drawer 14 is formed in the front panel of the safe 13, and this opening 13a is enabled to open and close by means of a front door 13b (Figures 2A and 2B).

[0021] The tag detection sensor 16 comprises an antenna 23 attached on a back surface of an upper wall in the vicinity of the opening 13a of the safe 13, and a tag detection circuit 24 electrically connected to a coil 23b of this antenna 23 (Figures 1, 2A, 2B, and 5). The antenna 23 has a core 23a that is made of ferrite and extends in the width direction of the safe 13, a coil 23b wound around this core 23a, and a pair of arm sections 23c and 23d, which is made of ferrite and is provided in both ends of the core 23a with protruding toward two tags 11 and 11 respectively. The core 23a, including the coil 23b, and a base end of the pair of arm sections 23c and 23d are covered with the wave absorber 26 (Figures and 5) and electromagnetic wave shielding member (not shown) through an insulator (not shown) such as a vinyl tape. In addition, if the pair of arm sections is not provided in both ends of the core with protruding, the periphery of a part of a core except a part of the core facing to the tag, that is, both ends of the core can be covered with the coil through the insulator with the wave absorber and electromagnetic wave shielding member. In addition, regardless of the presence or absence of the pair of arm sections, a part of the core not facing to the tag can be covered with the coil through the insulator with the wave absorber and electromagnetic wave shielding member.

[0022] The wave absorber 26 is a nonwoven fabric type wave absorber, and a wave absorber is used, the wave absorber which is a wave absorber comprising a nonwoven fabric composed of first fibers which are covered by oxidized metal and second fibers that is an insulator and is not covered by metal. In addition, a wave absorber composed of laminated nonwoven fabric sheets composed of the first fibers and second fibers is used. Furthermore, a wave absorber comprising a nonwoven fabric composed of a plurality of laminated layers composed of at least one layer of nonwoven fabric containing oxidized metal-coated fibers and one layer of nonwoven fabric containing non-oxidized metal-coated fibers is also used, the nonwoven fabric having a layer containing the oxidized metal-coated fibers which is located in the injection surface side of a radio wave. As metal coating the fibers and being oxidized, one or two kinds of metal, alloys, or the like that are selected from a group of silver, copper, nickel, and zinc are used.

[0023] In addition, as the wave absorber 26, a wave absorber comprising a nonwoven fabric composed of first fibers, which is coated with metal that is sulfided, and second fibers, which is an insulator and is not coated with metal, can be used. Furthermore, a wave absorber comprising a plurality of laminated nonwoven fabric sheets composed of the first and second fibers can be also used. Moreover, a wave absorber compris-

ing a nonwoven fabric composed of a plurality of laminated layers composed of at least one layer of nonwoven fabric containing sulfided metal-coated fibers and one layer of nonwoven fabric containing non-sulfided metal-coated fibers can be also used, the nonwoven fabric having a layer containing the sulfided metal-coated fibers which is located in the injection surface side of a radio wave. As metal coating the fibers and being sulfided, copper, a copper alloy, silver or a silver alloy is used.

[0024] In addition, it is preferable to use as an electromagnetic wave shielding member a nonwoven fabric comprising organic fibers coated with silver, a nonwoven fabric comprising a mixture of organic fibers and organic fibers coated with silver, or a laminated body comprising nonwoven fabrics comprising organic fibers and organic fibers coated with silver. Natural and synthetic organic fibers such as cotton, linen, regenerated cellulose, polyamide, acrylic fibers, polyolefine, polyester, and the like are used as the organic fibers. The purpose of coating the core 23a, including the coil 23b, and the pair of arm sections 23c and 23d with the wave absorber 26 and electromagnetic wave shielding member is to make it possible that electrical noise of a computer and the like is absorbed by the wave absorber 26 and is blocked from incidence into the core 23a of the antenna 23 by shutting off with the electromagnetic wave shielding member, and hence that a radio wave type burglar detection apparatus is prevented from malfunctioning. In addition, the purpose of providing the pair of arm sections 23c and 23d in both sides of the core 23a with protruding is to increase a ratio (S/N ratio) between a signal transmitted from the arm sections 23c and 23d and a signal generated by electrical noise of a computer and the like by a radio wave, transmitted from the pair of arm sections 23c and 23d, proceeding toward the tags 11 and 11, that is, making the radio wave have directivity.

[0025] The tag detection circuit 24, as shown in Figure 5, comprises: a voltage-controlled oscillator 24a that is electrically connected to the coil 23b of the antenna 23 and feeds a current, having the same frequency as a resonance frequency of the tag 11, through the coil 23b; a sweep block 24b sweeping the oscillating frequency of this oscillator 24a within the range of 7-9 MHz; an amplifier 24c whose input terminal is connected to the output terminal of an automatic gain controller in the voltage-controlled oscillator 24a; a noise filter 24d whose input terminal is connected to the output terminal of the amplifier 24c; and a threshold circuit 24e whose input terminal is connected to the output of the noise filter 24d. This tag detection circuit 24 is constructed so that, when the resonance circuit block 12 resonates by the tag 11 accessing the coil 23b, a specific signal may appear at the output terminal of the automatic gain controller of the voltage-controlled oscillator 24a. This specific signal is amplified by the amplifier 24c, a noise signal mixed in this signal is filtered by the noise filter 24d, and further the signal is selected by the threshold circuit

24e. If a waveform of the specific signal is not present in a waveform selected by the threshold circuit 24e, the threshold circuit 24e outputs the ON signal "1". In addition, if a waveform of the specific signal is present in a waveform selected by the threshold circuit 24e, the threshold circuit 24e outputs the OFF signal "0".

[0026] The drawer sensor 17 is a reed switch (Figures 1 and 2) attached to one internal surface of a side wall in the vicinity of the opening 13a of the safe 13. In addition, a magnet 27 is attached to an external surface of a side wall in the vicinity of the back end of the drawer 14. If the drawer 14 is contained in the safe 13, the magnet 27 is separated from the reed switch 17, and hence the reed switch outputs the signal "0" with keeping the OFF state. If the drawer 14 is drawn, the magnet 27 accesses the reed switch 17, and hence the reed switch outputs the signal "1" with turning on. One terminal of this reed switch 17 is connected to a power supply 28, and another terminal is connected to a control input terminal of an AND circuit 19, which is a control circuit, with the output terminal of the threshold circuit 24e (Figures 1 and 5). A first buzzer 18, which is alarm means, is connected to the control output terminal of the AND circuit 19 (Figure 1). The AND circuit 19 activates the first buzzer 18 only when the reed switch 17 outputs the signal "1" because of the drawer 17 being drawn and the threshold circuit 24e outputs the signal "1" because of the tag 11 not being present within the drawer 14.

[0027] A time constant circuit 29, which is composed of a resistor 29a and a capacitor 29b, is connected between the AND circuit 19 and first buzzer 18. When chattering at the output terminal of the threshold circuit 24e and the reed switch 17 arises, the time constant circuit 29 prevents the first buzzer 18 from malfunctioning. In particular, this is effective to a case that chattering arises at the output terminal of the threshold circuit 24e due to electrical noise that is caused by a cellular phone and the like and is not continuous but intermittent. The tag detection circuit 24, power supply 28, AND circuit 19, first buzzer 18, and time constant circuit 29 are contained in a case 31 attached to the external surface of a side wall of the safe 13 (Figures 1 and 2).

[0028] Operation of the radio wave type burglar detection apparatus constructed like this will be described.

[0029] If the drawer 14 is contained in the safe 13 and the front door 13b is closed (Figure 2A), the magnet 27 is separated from the reed switch 17, and hence the reed switch 17 outputs the signal "0" with keeping the OFF state. Therefore, even if an ON signal "1" is outputted from the threshold circuit 24e because the tag detection sensor 16 cannot detect the tags 11 and 11 due to the tags 11 and 11 not facing to the antenna 23, the AND circuit 19 does not activate the first buzzer 18 on the basis of respective detection outputs of the reed switch 17 and tag detection sensor 16.

[0030] If the front door 13b of the safe 13 is opened and the drawer 14 is drawn in a state of being able to take the bank notes 15 out (Figure 2B), the magnet 27

accesses the reed switch 17, and hence the reed switch 17 outputs the signal "1" owing to the magnetic intensity of the magnet 27 (Figure 1). Nevertheless, since the tag 11 faces to the antenna 23, the tag detection sensor 16 detects the two tags 11 and 11, and hence the threshold circuit 24e outputs the signal "0". In consequence, the AND circuit 19 does not activate the first buzzer 18 on the basis of respective detection outputs of the reed switch 17 and tag detection sensor 16.

[0031] In addition, even if one of the two tags 11 and 11 is taken out from the drawer with the bank notes 15, the tag detection sensor 16 continues to detect another residual tag 11, and hence the threshold circuit 24e continues to output the signal "0". In consequence, the AND circuit 19 does not activate the first buzzer 18 on the basis of respective detection outputs of the reed switch 17 and tag detection sensor 16. This is because it is considered that an owner of the safe 13 counts the bank notes 15 in the safe 13.

[0032] Furthermore, if all of the tags 11 and 11 are taken out with the bank notes 15 and 15 from the drawer 14 in the state of the reed switch 17 outputting the signal "1", the tag detection sensor 16 detects that the tags 11 and 11 are not present in the drawer 14, and hence the threshold circuit 24e outputs the signal "1". In consequence, the AND circuit 19 activates the first buzzer 18 on the basis of respective detection outputs of the reed switch 17 and tag detection sensor 16. Therefore, an owner of the safe 13 can immediately know that the bank notes 15 in the safe 13 are taken out without notice by an alarm sounded by the first buzzer 18, and hence can instantly report the incident to the police.

[0033] Figure 6 shows a second embodiment of the present invention. In Figure 6, the same symbols are assigned to the same components as those in Figure 1.

[0034] In this embodiment, the power supply 28 is connected in series to the tag detection circuit 24 through the reed switch 17, and this series circuit constructs a control circuit 49. Except the above construction this embodiment has the same construction as the first embodiment has.

[0035] Since the operation of a radio wave type burglar detection apparatus constructed like this is the approximately same as the operation of the first embodiment, repeated description will be omitted.

[0036] Figures 7 and 8 show a third embodiment of the present invention. In Figures 7 and 8, the same symbols are assigned to the same components as those in Figures 1 and 2.

[0037] In this embodiment, an opening 63a is provided in the upper side of the safe 63 made of metal material, and an upper lid 63b that can open and close the opening 63a is installed in the upper surface of this safe 63. Furthermore, a loop antenna 73 that is circular or square and consists of a plurality of turns of wire is used as an antenna of a tag detection sensor 66. In the safe 63, a soft magnetic member 72 made of the same material as that of the soft magnetic member 22 in the first

embodiment is placed, and two tags 11 and 11 are placed in parallel to each other on this soft magnetic member 72. Thus, the soft magnetic member 72 is sandwiched between the tags 11 and 11, and the safe 63. In addition, on these tags 11 and 11, plenty of bank notes 15 and 15 are piled respectively. The loop antenna 73 is placed to become above between the two tags 11 and 11 in the safe 63, and both ends of this antenna 73 are electrically connected to the tag detection circuit 24. In addition, the surface of the loop antenna 73 not facing to the tags 11 and 11 is covered by a wave absorber 76 and an electromagnetic wave shielding member (not shown) through an insulator (not shown).

[0038] In addition, an upper lid sensor 67 is mounted to the inside of a side wall in the vicinity of the opening 63a of the safe 63. This sensor 67 is a micro switch, which outputs the signal "0" with turning off at the time of closing the upper lid 63b, and which outputs the signal "1" with turning on at the time of opening the upper lid 63b. The AND circuit 19, which is a control circuit, activates the first buzzer 18 only when the micro switch 67 outputs the signal "1" because of the upper lid 63b being opened and a threshold circuit (not shown) in the tag detection circuit 24 outputs an ON signal "1" because of the tag 11 not being present within the safe 63. The tag detection circuit 24, power supply 28, AND circuit 19, first buzzer 18, and time constant circuit 29 are contained in a case 81 mounted to the external surface of a back wall of the safe 63. The construction of this embodiment except the above construction is the same as that of the first embodiment.

[0039] In the radio wave type burglar detection apparatus constructed like this, if the upper lid 63b is closed (Figure 8A), the tag detection sensor 66 detects that the tags 11 and 11 are present in the safe 63, and hence the tag detection circuit 24 outputs the signal "0". Since the micro switch 67 outputs the signal "0", the AND circuit 19 does not activate the first buzzer 18. In addition, if the upper lid 63b is opened (Figure 8B), the micro switch 67 outputs the signal "1" (Figure 1), but the tag detection sensor 66 detects that the tags 11 and 11 are present in the safe 63, and hence the tag detection circuit 24 outputs the signal "0". In consequence, the AND circuit 19 does not activate the first buzzer 18.

[0040] In addition, even if one of the two tags 11 and 11 is taken out from the safe 63 with the bank notes 15, the tag detection sensor 66 continues to detect another residual tag 11 in the safe 63, and hence the tag detection circuit 24 continues to output the signal "0". In consequence, the AND circuit 19 does not activate the first buzzer 18. Furthermore, if all of the tags 11 and 11 are taken out with the bank notes 15 and 15 from the safe 63 in the state of the upper lid being opened (the micro switch 67 outputting the signal "1"), the tag detection sensor 66 detects that the tags 11 and 11 are not present in the safe 63, and hence the tag detection circuit 24 outputs the signal "1". Hence, the AND circuit 19 activates the first buzzer 18. In consequence, an owner of

the safe 63 can immediately know that the bank notes 15 in the safe 63 are taken out without notice by an alarm sounded by the first buzzer 18, and hence can instantly report the incident to the police.

5 **[0041]** Figure 9 shows a fourth embodiment of the present invention. In Figure 9, the same symbols are assigned to the same components as those in Figure 1.

[0042] This embodiment comprises a self operation management circuit 811 detecting abnormal operation of the tag 11, tag detection sensor 16 or reed switch 17. This self operation management circuit 811 has an exclusive OR circuit 82 and an inverting circuit 83. A first input terminal 82a out of two input terminals 82a and 82b of the exclusive OR circuit 82 is connected to the output side of the tag detection circuit 24, and a second input terminal 82b is connected to the ground side of the reed switch 17 respectively. The inverting circuit 83 is connected between the first input terminal 82a and tag detection circuit 24. In addition, the output terminal 82c of the exclusive OR circuit 82 is connected to a second buzzer 86, which is information means, through a time constant circuit 84.

[0043] If ON signals "1" or OFF signals "0" are inputted to all of the first and second input terminals 82a and 82b of the exclusive OR circuit 82, the exclusive OR circuit 82 outputs the signal "0". If the signal "0" is inputted to either of the first or second input terminal 82a or 82b and the signal "1" is inputted to the other terminal, the exclusive OR circuit 82 outputs the signal "1". Thus, the exclusive OR circuit 82 has the input and output relation shown in Table 1.

Table 1

1st Input	2nd Input	Output
0	0	0
0	1	1
1	0	1
1	1	0

[0044] If the signal "0" is inputted, the inverting circuit 83 outputs the signal "1", and if the signal "1" is inputted, the inverting circuit 83 outputs the signal "0". In addition, the second buzzer 86 is constructed to have a tone different from that of the first buzzer 18 that is the alarm means. The buzzer 86 is not activated if the exclusive OR circuit 82 outputs the signal "0", and is activated if outputting the signal "1". In addition, as information means, a lamp and the like can be used instead of the buzzer. Furthermore, the time constant circuit 84 consists of a resistor 84a and a capacitor 84b, and absorbs a time lag between the tag detection circuit 24 and reed switch 17. Thus, even if the outputs of the tag detection circuit 24 and reed switch 17 instantly become unstable due to the time lag at the time of drawing or containing the drawer 14 and hence the exclusive OR circuit 82

outputs the signal "1" in an instant, the second buzzer 86 is not activated owing to the time constant circuit 84. In addition, the time constant circuit 84 has a function of preventing the second buzzer 86 from being activated when external noise that is intermittent is received. The construction except the above construction is the same as that of the first embodiment.

[0045] The operation of the radio wave type burglar detection apparatus constructed like this will be described.

[A] A case that all of the tag 11, tag detection sensor 16, and reed switch 17 normally operate

[0046] Since the tag 11 does not face to the antenna 23 if the drawer 14 is contained in the safe 13, the tag detection sensor 16 cannot detect the tag 11, and hence the tag detection circuit 24 outputs the ON signal "1". This ON signal "1" from the tag detection circuit 24 is inverted by the inverting circuit 83 and is outputted to the first input terminal 82a of the exclusive OR circuit 82. On the other hand, the reed switch 17 is turned off because the reed switch 17 is separated from the magnet 27, and hence the OFF signal "0" is outputted to the second input terminal 82b of the exclusive OR circuit 82. In consequence, the exclusive OR circuit 82 outputs the signal "0" to the second buzzer 86, and hence the second buzzer 86 is not activated. At this time, since the output of the tag detection circuit 24 is the signal "0" and the output of the reed switch 17 is the signal "0", the first buzzer 18 is not activated.

[0047] In addition, if the drawer 14 is drawn from the safe 13, the tag 11 faces to the antenna 23, the tag detection sensor 16 detects the tag 11, and the tag detection circuit 24 outputs the OFF signal "0". This output "0" from the tag detection circuit 24 is inverted by the inverting circuit 83 into the signal "1" to be outputted to the first input terminal 82a of the exclusive OR circuit 82. On the other hand, since the reed switch 17 is turned on because the magnet 27 accesses the reed switch 17, the ON signal "1" is outputted to the second input terminal 82b of the exclusive OR circuit 82. In consequence, since the exclusive OR circuit 82 outputs the signal "0" to the second buzzer 86, the second buzzer 86 is not activated. At this time, since the output of the tag detection circuit 24 is the signal "0" and the output of the reed switch 17 is the signal "1", the first buzzer 18 is not activated.

[0048] Furthermore, if the two tags 11 and 11 are taken out from the drawer 14 in the state of the drawer 14 being drawn from the safe 13, the tag detection sensor 16 does not detect the tag 11 because the tag 11 does not face to the antenna 23, and hence the tag detection circuit 24 outputs the ON signal "1". This output "1" from the tag detection circuit 24 is inverted into the signal "0" by the inverting circuit 83 to be outputted to the first input terminal 82a of the exclusive OR circuit 82. On the other hand, since the reed switch 17 keeps the state of ac-

cessing the magnet 27, the reed switch 17 outputs the ON signal "1" to the second input terminal 82b of the exclusive OR circuit 82. In consequence, since the exclusive OR circuit 82 outputs the signal "1" to the second buzzer 86, the second buzzer 86 is activated in a tone different from that of the first buzzer 18. At this time, since the output of the tag detection circuit 24 is the signal "1" and the output of the reed switch 17 is the signal "1", the first buzzer 18 is activated. Thus, if the bank notes 15 in the safe 13 are taken out without notice, not only the first buzzer 18 but also the second buzzer is activated. Nevertheless, since the tag 11 is taken out with the bank notes 15 from the drawer 14, it is possible to judge that the bank notes 15 are taken out without notice.

[B] A case that the tag detection sensor 16 abnormally operates due to a failure

[0049] A tag detection sensor 16 abnormally operates due to abnormal oscillation of a voltage-controlled oscillator (not shown), abnormal operation of an amplifier (not shown), or a failure or disconnection of a wire of another part constructing the tag detection sensor 16. Therefore, in spite of the tag 11 not facing to the antenna 23, the tag detection circuit 24 outputs the OFF signal "0" as if the tag detection sensor 16 detected the tag 11. This output "0" from the tag detection circuit 24 is inverted into the signal "1" by the inverting circuit 83 to be inputted to the first input terminal 82a of the exclusive OR circuit 82. On the other hand, since the normal reed switch 17 is turned off because the reed switch 17 is separated from the magnet 27, the reed switch 17 outputs the signal "0" to the second input terminal 82b of the exclusive OR circuit 82. In consequence, since the exclusive OR circuit 82 outputs the signal "1" to the second buzzer 86, the second buzzer 86 is activated in a tone different from that of the first buzzer 18. At this time, since the output of the tag detection circuit 24 is the signal "0" and the output of the reed switch 17 is the signal "0", the first buzzer 18 is not activated.

[0050] In addition, if the drawer 14 is drawn from the safe 13, the tag detection sensor 16 abnormally operates and the tag detection circuit 24 outputs the signal "1", which is the signal showing absence of the tag 11, in spite of the tag 11 facing to the antenna 23. This output "1" from the tag detection circuit 24 is inverted into the signal "0" by the inverting circuit 83 to be inputted to the first input terminal 82a of the exclusive OR circuit 82. On the other hand, since the normal reed switch 17 is turned on because the magnet 27 accesses the reed switch 17, the reed switch 17 outputs the signal "1" to the second input terminal 82b of the exclusive OR circuit 82. In consequence, since the exclusive OR circuit 82 outputs the signal "1" to the second buzzer 86, the second buzzer 86 is activated. At this time, since the output of the tag detection circuit 24 is the signal "0" and the output of the reed switch 17 is the signal "1", the first

buzzer 18 is not activated.

[C] A case that the reed switch 17 abnormally operates due to a failure

[0051] Since the tag 11 does not face to the antenna 23 if the drawer 14 is contained in the safe 13, the tag detection sensor 16 cannot detect the tag 11, and hence the tag detection circuit 24 outputs the ON signal "1". This ON signal "1" from the tag detection circuit 24 is inverted into the signal "0" by the inverting circuit 83 and is outputted to the first input terminal 82a of the exclusive OR circuit 82. On the other hand, the reed switch 17, which abnormally operates due to a contact failure, a short-circuit of wiring, and the like, is turned on in spite of the magnet 27 being separated from the reed switch 17. Hence, the OFF signal "0" is outputted to the second input terminal 82b of the exclusive OR circuit 82. In consequence, the exclusive OR circuit 82 outputs the signal "1" to the second buzzer 86, and hence the second buzzer 86 is activated. At this time, since the output of the tag detection circuit 24 is the signal "1" and the output of the reed switch 17 is the signal "1", the first buzzer 18 is activated.

Nevertheless, since the first and second buzzer 18 and 86 are activated in the state of the drawer 14 being contained in the safe 13, it is possible to judge that the reed switch 17 is failed.

[0052] In addition, if the drawer 14 is drawn from the safe 13, the tag 11 faces to the antenna 23, the tag detection sensor 16 detects the tag 11, and the tag detection circuit 24 outputs the OFF signal "0". This output "0" from the tag detection circuit 24 is inverted by the inverting circuit 83 into the signal "1" to be outputted to the first input terminal 82a of the exclusive OR circuit 82. On the other hand, since the reed switch 17, which abnormally operates, is turned off in spite of the magnet 27 accessing the reed switch 17, the signal "0" is outputted to the second input terminal 82b of the exclusive OR circuit 82. In consequence, since the exclusive OR circuit 82 outputs the signal "1" to the second buzzer 86, the second buzzer 86 is activated. At this time, since the output of the tag detection circuit 24 is signal "0" and the output of the reed switch 17 is the signal "0", the first buzzer 18 is not activated.

[D] A case that the tag 11 abnormally operates due to a failure

[0053] Even if the tag 11 is failed due to disconnection of a wire and the like if the drawer 14 is contained in the safe 13, this tag 11 does not face to the antenna 23, and hence the normal tag detection sensor 16 cannot detect the tag 11. Hence, the tag detection circuit 24 outputs the ON signal "1". This ON signal "1" from the tag detection circuit 24 is inverted into the signal "0" by the inverting circuit 83 and is outputted to the first input terminal 82a of the exclusive OR circuit 82. On the other

hand, the normal reed switch 17 is turned off since the magnet 27 is separated from the reed switch 17, and hence, the OFF signal "0" is outputted to the second input terminal 82b of the exclusive OR circuit 82. In consequence, the exclusive OR circuit 82 outputs the signal "0" to the second buzzer 86, and hence the second buzzer 86 is not activated. At this time, since the output of the tag detection circuit 24 is the signal "1" and the output of the reed switch 17 is the signal "0", the first buzzer 18 is not activated.

[0054] Nevertheless, if the drawer 14 is drawn from the safe 13, the normal tag detection sensor 16 cannot detect the failed tag 11 in spite of the tag 11 facing to the antenna 23, and hence the tag detection circuit 24 outputs the signal "1". This output "1" from the tag detection circuit 24 is inverted by the inverting circuit 83 into the signal "0" to be outputted to the first input terminal 82a of the exclusive OR circuit 82. On the other hand, since the normal reed switch 17 is turned on since the magnet 27 accesses the reed switch 17, the signal "1" is outputted to the second input terminal 82b of the exclusive OR circuit 82. In consequence, since the exclusive OR circuit 82 outputs the signal "1" to the second buzzer 86, the second buzzer 86 is activated. At this time, since the output of the tag detection circuit 24 is signal "1" and the output of the reed switch 17 is the signal "1", the first buzzer 18 is activated. Nevertheless, although the first and second buzzers 18 and 86 are activated in the state of the drawer 14 being drawn from the safe 13, the tag 11 is present in the drawer 14, and hence it is possible to judge that the tag 11 is failed.

[0055] In this manner, if the tag detection sensor 16, reed switch 17, or tag 11 abnormally operates due to a failure and the like, the self operation management circuit 811 immediately detects this abnormal operation and activates the second buzzer 86. Therefore, an owner of the safe 13 can instantly know the failure of the radio wave type burglar detection apparatus. Hence, since it is possible to repair or replace this apparatus failed or malfunctioned, it is possible to increase the reliability of the radio wave type burglar detection apparatus of the present invention. In addition, by transmitting the output of the self operation management circuit 811 with the output of the AND circuit 19 (control circuit) to a security guard company or the like, personnel of the security guard company or the like, which receives the alarm, go to the location, and can judge whether the alarm is an alarm or a failure.

[0056] Figure 10 shows a fifth embodiment of the present invention. In Figure 10, the same symbols of Figure 7 are assigned to the same components.

[0057] This embodiment comprises a self operation management circuit 91 detecting abnormal operation of the tag 11 or tag detection sensor 66. This self operation management circuit 91 is a branch circuit branching from the output side of the tag detection circuit 24. The second buzzer 86 that is information means is connected to this branch circuit 91 through the time constant

circuit 84 composed of the resistor 84a and capacitor 84b. The time constant circuit 84 has a function of preventing the second buzzer 86 from being activated when receiving intermittent external noise. In addition, a lamp or the like can be used as information means instead of the buzzer. The construction except the above construction is the same as that of the third embodiment.

[0058] The operation of the radio wave type burglar detection apparatus constructed like this will be described.

[E] A case that both of the tag 11 and tag detection sensor 66 normally operate

[0059] If the upper lid 63b is closed, the tag 11 faces to the loop antenna 73, and hence the tag detection sensor 66 detects that the tags 11 and 11 are present in the safe 63, and the tag detection circuit 24 outputs the OFF signal "0". Therefore, the self operation management circuit 91 does not activate the second buzzer 86. At this time, since the output of the tag detection circuit 24 is the signal "0" and the output of the micro switch 67 is the signal "0", the first buzzer 18 is not activated.

[0060] In addition, even if the upper lid 63b is opened, the tag 11 faces to the loop antenna 73, and hence, similarly to the above, the tag detection circuit 24 outputs the OFF signal "0". In consequence, the self operation management circuit 91 does not activate the second buzzer 86. At this time, since the output of the tag detection circuit 24 is the signal "0" and the output of the micro switch 67 is the signal "1", the first buzzer 18 is not activated.

[0061] In addition, if the two tags 11 and 11 are taken out from the safe 63 in the state of the upper lid 63b being opened, the tag 11 does not face to the loop antenna 73, and hence the tag detection sensor 66 does not detect the tag 11. Hence, the tag detection circuit 24 outputs the ON signal "1", and the self operation management circuit 91 activates the second buzzer 86 in a tone different from that of the first buzzer 18. At this time, since the output of the tag detection circuit 24 is the signal "1" and the output of the micro switch 67 is the signal "1", the first buzzer 18 is activated. Thus, if the bank notes 15 in the safe 63 are taken out with the tag 11 without notice, not only the first buzzer 18 but also the second buzzer 86 are activated. Nevertheless, since the tag 11 is taken out with the bank notes 15 from the safe 63, it is possible to judge that the bank notes 15 are taken out without notice.

[F] A case that the tag detection sensor 66 abnormally operates due to a failure

[0062] If the upper lid 63b is closed, a tag detection sensor 66 abnormally operates due to abnormal oscillation of a voltage-controlled oscillator (not shown), abnormal operation of an amplifier (not shown), or a failure or disconnection of a wire of another part constructing

the tag detection sensor 66. Therefore, in spite of the tag 11 facing to the loop antenna 73, the tag detection circuit 24 outputs the ON signal "1" as if the tag detection sensor 66 did not detect the tag 11. Hence, the self operation management circuit 91 activates the second buzzer 86. At this time, since the output of the tag detection circuit 24 is the signal "1" and the output of the micro switch 67 is the signal "0", the first buzzer 18 is not activated.

[0063] In addition, if the upper lid 63b is opened, the tag detection sensor 66 outputs the signal "1", which shows that the tag 11 is not detected, in spite of the tag 11 facing to the loop antenna 73. Hence, the self operation management circuit 91 activates the second buzzer 86. At this time, since the output of the tag detection circuit 24 is the signal "1" and the output of the micro switch 67 is the signal "1", the first buzzer 18 is activated.

[G] A case that the tag 11 abnormally operates due to a failure

[0064] If the tag 11 is failed due to disconnection of a wire and the like when the upper lid 63b is closed, the normal tag detection sensor 66 cannot detect the tag 11 in spite of the tag 11 facing to the loop antenna 73, and hence the tag detection circuit 24 outputs the ON signal "1". Therefore, the self operation management circuit 91 activates the second buzzer 86. At this time, since the output of the tag detection circuit 24 is the signal "1" and the output of the micro switch 67 is the signal "0", the first buzzer 18 is not activated.

[0065] In addition, if the upper lid 63b is opened, the tag detection circuit 24 outputs the signal "1" in spite of the tag 11, similarly to the above, facing to the loop antenna 73. Hence, the self operation management circuit 91 activates the second buzzer 86. At this time, since the output of the tag detection circuit 24 is the signal "1" and the output of the micro switch 67 is the signal "1", the first buzzer 18 is activated.

[0066] If the tag 11 is present in the safe 63 like the above-described examples [F] and [G] and the second buzzer 86 is activated regardless of open and close of the upper lid 63b, it is possible to judge that the tag detection sensor 66 or tag 11 is failed.

[0067] In this manner, if the tag detection sensor 66 or tag 11 abnormally operates due to a failure and the like, the self operation management circuit 91 immediately detects this abnormal operation and activates the second buzzer 86. Therefore, an owner of the safe 63 can instantly know the failure of the radio wave type burglar detection apparatus. Hence, since it is possible to repair or replace this apparatus failed or malfunctioned, it is possible to increase the reliability of the radio wave type burglar detection apparatus of the present invention. In addition, by transmitting the output of the self operation management circuit 91 with the output of the AND circuit 19 (control circuit) to a security guard company or the like, personnel of the security guard compa-

ny or the like, which receives the alarm, go to the location, and can judge whether the alarm is an alarm or a failure.

[0068] In addition, although a safe is cited as a box in the first through fifth embodiments, a show window case for displaying precious metal, a cash register that is a terminal of a POS (Point Of Sales) system, and the like also can be used as the box. In addition, although a buzzer is cited as alarm means in the first through third embodiments, a lamp or other alarm means also can be used, and this alarm means can be installed in a security guard company and the like. In this case, since the security guard company and the like can immediately know a burglar and the like of bank notes from a safe, the company can correspond to this matter immediately.

[0069] Furthermore, although a first buzzer is cited as alarm means and a second buzzer is cited as information means in the fourth and fifth embodiments, a lamp and other alarm means can be used as the alarm means and a lamp and other information means can be used as the information means.

[0070] Moreover, although plenty of bank notes are piled on a tag in the first through fifth embodiments, checks, important papers, and the like can be placed, and a bundle of a tag, plenty of bank notes, and the like can be contained in one piece in a drawer or the box. In this case, if the bank notes and the like are taken out from the drawer or box, the tag is always taken out with them, and hence it is possible to surely detect a burglar of the bank notes and the like. In addition, if the objects to be contained in a safe are metals such as bar gold and precious metal articles, a radio wave is cut off with the metals in case of these metals being placed of the tag. Hence, it is preferable to place the metal beside the tag and to bind the metal to the tag.

[0071] In addition, although two tags are contained in a drawer or a box in the first through fifth embodiments, one or three tags also can be contained. If three or more tags are contained, it is necessary to extend an antenna without using a pair of arm sections in the first, second, and fourth embodiments. Nevertheless, since the antenna in the third embodiment is a loop antenna, all tags can be detected without extending the antenna.

[0072] Furthermore, a core or a loop antenna of a tag detection sensor are covered with both of a wave absorber and an electromagnetic wave shielding member in the first through fifth embodiments, either of the wave absorber or electromagnetic wave shielding member can be used for covering.

[0073] Moreover, a loop antenna can be used as the antenna in the first and second embodiments, and a core where a coil is wound can be used as the antenna in the third embodiment.

[0074] In addition, the figures of the resonance frequency cited in the first embodiment are examples, and hence the present invention is not limited to this range.

[0075] Moreover, the self operation management circuit cited in the fourth embodiment can be provided in

the radio wave type burglar detection apparatus according to the second embodiment.

Industrial Applicability

[0076] As described above, according to the present invention, a radio wave type burglar detection apparatus has such a construction that a tag having a resonance circuit block is placed with an object in a predetermined location, a tag detection sensor that is installed near the tag placed in this predetermined location detects whether the tag is present in the predetermined place, and a control circuit controls alarm means on the basis of the detection output of this sensor. Hence, if the tag is placed with the object in the predetermined location, the control circuit does not activate the alarm means on the basis of the detection output of the tag detection sensor. If the tag is taken out with the object from the predetermined location, the control circuit activates the alarm means on the basis of the detection output of the tag detection sensor. In consequence, it is possible to surely detect whether the tag is present in the predetermined location.

[0077] In addition, by containing a tag, which has a resonance circuit block, with an object in a drawer, containing this drawer in a box, detecting by a tag detection sensor, which is installed in this box, whether the tag is present in the drawer, detecting by a drawer sensor whether the drawer is drawn, and controlling alarm means by a control circuit, the drawer sensor detects that the drawer is not drawn regardless of the tag being present in the drawer if the box contains the drawer. Hence, the control circuit does not activate the alarm means. Furthermore, if the drawer is drawn from the box, the drawer sensor detects that the drawer is drawn, and the tag detection sensor detects that the tag is present in the drawer. Therefore, the control circuit does not activate the alarm means. Moreover, if the tag is taken out with the object from the drawer with the drawer being drawn, the tag detection sensor detects that the tag is absent in the drawer. Hence, the control circuit activates the alarm means. In consequence, it is possible to surely detect whether the tag is taken out from the drawer.

[0078] Furthermore, by containing a tag, which has a resonance circuit block, with an object in a box having an upper lid that can be opened and closed, detecting whether the tag is present in the box by a tag detection sensor installed in the box, detecting open and close of the upper lid by an upper lid sensor, and controlling alarm means on the basis of respective detection outputs of these sensors by a control circuit, the upper lid sensor detects regardless of presence or absence of the tag in the box that the upper lid is not opened if the upper lid is closed. Therefore, the control circuit does not activate the alarm means. Moreover, if the upper lid is opened, the upper lid sensor detects that the upper lid is opened, and the tag detection sensor detects that the

tag is present in the box. Hence, the control circuit does not activate the alarm means. In addition, if the tag is taken out with the object from the box with the upper lid being opened, the tag detection sensor detects that the tag is absent in the box, and hence the control circuit activates the alarm means. In consequence, it is possible to surely detect whether the tag is taken out from the box.

[0079] Moreover, by placing a tag and an object in one piece in a predetermined location, or containing the tag with the object in one piece in a drawer or a box, the tag is always taken out from the predetermined location or from the drawer or box if the object is taken out from the predetermined location or from the drawer or box. Therefore, it is possible to surely detect a burglar of the object.

[0080] In addition, if a drawer or a box is made of metal material, a magnetic field easily passes to the resonance circuit block of the tag by means of a soft magnetic member by sandwiching a soft magnetic member made of a sintered ferrite, a compact of ferrite powder and binder, or composite material of soft magnetic metal powder between the tag and drawer or box. Therefore, even if the drawer or box is made of metal material, it is possible to surely detect the tag by the tag detection sensor.

[0081] Furthermore, by covering a ferrite core, where a coil of a tag detection sensor is wound, and at least a part of a loop antenna, which does not face to a tag, with a wave absorber and an electromagnetic wave shielding member, electrical noise is absorbed by the wave absorber and is cut off by the electromagnetic wave shielding member even if the radio wave type burglar detection apparatus of the present invention is installed in a location with plenty of electrical noise of a computer and the like. Therefore, it is possible to block injection of the electrical noise into the core of the tag detection sensor or the loop antenna, and hence it is possible to prevent the apparatus from malfunctioning.

[0082] Moreover, by providing a pair of arm sections in both sides of a core with protruding toward a tag, it is possible to make a radio wave, which is transmitted from these arm sections, have directivity. Therefore, it is possible to increase a ratio (S/N ratio) between a signal transmitted from the arm sections and a signal generated by electrical noise of a computer and the like. In consequence, it is possible to increase the sensitivity of the tag detection sensor, and hence to surely detect presence and absence of the tag by the tag detection sensor.

[0083] In addition, by detecting the abnormal operation of a tag, a tag detection sensor, a drawer sensor, or an upper lid sensor by a self operation management circuit, the self operation management circuit immediately detects the abnormal operation if the tag or the like abnormally operates due to a failure or the like. Therefore, it is possible to rapidly repair or replace the tag or the like that abnormally operates. In consequence, it is possible to increase the reliability of the radio wave type

burglar detection apparatus of the present invention.

Claims

1. Radio wave type burglar detection apparatus comprising a tag (11), a resonance circuit block (12), a tag detection sensor (16; 66) and a control circuit (19) controlling alarm means (18) on the basis of a detection output of the tag detection sensor (16; 66), the tag (11) and the resonance circuit block (12) being placed together with an object (15) in a predetermined location (13; 63) in which the radio wave tag detection sensor (16; 66) is installed for detecting whether the tag (11) and the object (15) are present in the predetermined location (13; 63), **characterized in that**

a) the predetermined location (13) wherein the tag (11) having a resonance circuit block (12) is installed is a box (13) containing a drawer (14), where the tag (11) is contained with an object (15), the tag detection sensor (16) being installed in the box (13) and detects whether the tag (11) is present within the drawer (14); a drawer sensor (17) detecting whether the drawer (14) is drawn and the control circuit (19) controlling the alarm means (18) on the basis of each detection output of the tag detection sensor (16) and the drawer sensor (17),
or

b) the predetermined location wherein the tag (11) having a resonance circuit block (12) is installed is a box (63) that contains the tag (11) with an object (15) and having an upper lid (63b) that can be opened and closed, the tag detection sensor (66) being installed in the box (63) and detects whether the tag (11) is present within the box (63); an upper lid sensor (67) detecting whether the upper lid (63b) is opened or closed, the control circuit (19) controlling the alarm means (18) on the basis of each detection output of the tag detection sensor (66) and the upper lid sensor (67).

2. Apparatus according to claim 1, wherein the tag (11) is placed with the object (15) in one piece in the predetermined location (13;63).

3. Apparatus according to claim 1 or 2, wherein the drawer (14) or the box (63) is made of metal material, and a soft magnetic member (22, 72) is sandwiched between the tag (11) and the drawer (14) or the box (63).

4. Apparatus according to claim 3, wherein the soft magnetic member (22;72) is made of sintered ferrite, a compact of ferrite powder and binder, or a

composite material of soft magnetic metal powder.

5. Apparatus according to any one of claims 1 to 4, wherein the tag detection sensor (16) has a ferrite core (23a), whereon a coil is wound, and at least a part of the core (23a), which does not face to the tag (11), is covered with the coil (23b) by either or both of a wave absorber (26) and an electromagnetic wave shielding member.
6. Apparatus according to claim 5, wherein a pair of arm sections (23c,23d) made of ferrite is provided a both ends of the core (23a) with protruding toward the tag (11).
7. Apparatus according to any one of claims 1 to 6, wherein the tag detection sensor (66) has a loop antenna (73), and a surface of the loop antenna (73), and a surface of the loop antenna (73), which does not face to the tag (11), is covered by either or both of the wave absorber (76) and the electromagnetic wave shielding member.
8. Apparatus according to any of claims 1 to 7, wherein a self operation management circuit (81;91) detecting abnormal operation of a tag (11), the tag detection sensor (16;66), or the drawer sensor (17) is provided.

Patentansprüche

1. Auf Radiowellen basierende Einbrecherdetektionsvorrichtung, umfassend ein Etikett (11), ein Resonanzkreisblock (12), ein Etikettdetektionssensor (16; 66) und eine Steuerschaltung (19), die Alarmmittel (18) auf der Basis eines Detektionsoutputs des Etikettdetektionssensor (16; 66) steuert, wobei das Etikett (11) und der Resonanzkreisblock (12) mit einem Objekt (15) zusammen an einem vorbestimmten Ort (13; 63) platziert werden, an dem der Radiowellenetikettdetektionssensor (16; 66) installiert ist, um zu detektieren, ob das Etikett (11) und das Objekt (15) an dem vorbestimmten Ort (13; 63) vorhanden sind,
dadurch gekennzeichnet, dass

a) der vorbestimmte Ort (13), an dem das einen Resonanzkreisblock (12) aufweisende Etikett (11) installiert ist, eine Box (13) ist, die eine Schublade (14), in der das Etikett (11) mit einem Objekt (15) enthalten ist, wobei der Etikett-detektionssensor (16) in der Box (13) installiert ist und detektiert, ob das Etikett (11) innerhalb der Schublade (14) vorhanden ist, einen Schubladensensor (17), der detektiert, ob die Schublade (14) herausgezogen ist, und die Steuerschaltung (19), die die Alarmmittel (18)

auf der Basis jedes Detektionsoutputs des Etikett-detektionssensor (16) und des Schubladensensors (17) steuert, enthält, oder

b) der vorbestimmte Ort, an dem das einen Resonanzkreisblock (12) aufweisende Etikett (11) installiert ist, eine Box (63) ist, die das Etikett (11) mit einem Objekt (15) enthält und einen oberen Deckel (63b) aufweist, der geöffnet und geschlossen werden kann, wobei der Etikett-detektionssensor (66) in der Box (63) installiert ist und detektiert, ob das Etikett (11) innerhalb der Box (63) vorhanden ist, einen Sensor (67) des oberen Deckels, der detektiert, ob der obere Deckel (63b) geöffnet oder geschlossen ist, die Steuerschaltung (19), die die Alarmmittel (18) auf der Basis jedes Detektionsoutputs des Etikett-detektionssensors (66) und des Sensors (67) des oberen Deckels steuert, enthält.

2. Vorrichtung nach Anspruch 1, bei der das Etikett (11) mit dem Objekt (15) in einem Stück an dem vorbestimmten Ort (13; 63) platziert wird.
3. Vorrichtung nach den Ansprüchen 1 oder 2, bei der die Schublade (14) oder die Box (63) aus metallischem Material gemacht ist, und ein weichmagnetisches Teil (22; 72) ist zwischen dem Etikett (11) und der Schublade (14) oder der Box (63) angeordnet.
4. Vorrichtung nach Anspruch 3, bei der das weichmagnetische Teil (22; 72) aus gesinterter Ferrit, einem Presskörper aus Ferritpulver und Binder, oder einem Verbundwerkstoff aus weichmagnetischem Metallpulver gemacht ist.
5. Vorrichtung nach irgendeinem der Ansprüche 1 bis 4, bei der ein Etikett-detektionssensor (16) einen Ferritkern (23a) aufweist, auf den eine Spule gewunden ist, und zumindest ein Teil des Kerns (23a), der nicht dem Etikett (11) zugewandt ist, ist mit der Spule (23b) entweder durch einen Wellenabsorber (26), oder ein Teil zur elektromagnetischen Abschirmung, oder durch beides bedeckt.
6. Vorrichtung nach Anspruch 5, bei der ein Paar aus Ferrit gemachte Armabschnitte (23c, 23d) an beiden Enden des Kerns (23a) mit Vorsprung zum Etikett (11) hin vorgesehen ist.
7. Vorrichtung nach irgendeinem der Ansprüche 1 bis 6, bei der der Etikett-detektionssensor (66) eine Rahmenantenne (73) aufweist, und eine Oberfläche der Schleifenantenne (73) die nicht dem Etikett (11) zugewandt ist, ist entweder durch einen Wellenabsorber (76), oder ein Teil zur elektromagnetischen Abschirmung, oder durch beides bedeckt.

schen Abschirmung, oder durch beides bedeckt.

8. Vorrichtung nach irgendeinem der Ansprüche 1 bis 7, bei der eine selbsttätige Verwaltungsschaltung (81; 91), die anormalen Betrieb eines Etiketts (11), des Etikettdetektionssensors (16; 66) oder des Schubladensensors (17) detektiert, bereitgestellt wird.

Revendications

1. Dispositif antivol à radiofréquence comprenant une étiquette (11), un bloc de circuit de résonance (12), un palpeur de détection d'étiquette (16; 66) et un circuit de commande (19), qui commande des moyens d'alarme (18) sur la base d'une sortie de détection du palpeur de détection d'étiquette (16; 66), l'étiquette (11) et le bloc de circuit de résonance (12) étant placés ensemble avec un objet (15) à un endroit prédéterminé (13 ; 63), où le palpeur de détection d'étiquette à radiofréquence (16 ; 66) est installé pour détecter si l'étiquette (11) et l'objet (15) sont présents à l'endroit prédéterminé (13 ; 63), **caractérisé en ce que**

a) l'endroit prédéterminé (13) où l'étiquette (11) comprenant un bloc de circuit de résonance (12) est installée, est un boîtier (13) comprenant un tiroir (14), dans lequel l'étiquette (11) est contenue avec un objet (15), le palpeur de détection d'étiquette (16) étant installé dans le boîtier (13) pour détecter si l'étiquette (11) est présente dans le tiroir (14), un détecteur de tiroir (17) détectant si le tiroir (14) est tiré et le circuit de commande (19) commandant les moyens d'alarme (18) sur la base de chaque sortie de détection du palpeur de détection d'étiquette (16) et du détecteur de tiroir (17),

b) l'endroit prédéterminé où l'étiquette (11) comprenant un bloc de circuit de résonance (12) est installée, est un boîtier (63) qui contient l'étiquette (11) avec un objet (15) et qui comprend un couvercle supérieur (63b) qu'on peut ouvrir et fermer, le palpeur de détection d'étiquette (66) étant installé dans le boîtier (63) pour détecter si l'étiquette (11) est présente dans le boîtier (63), un détecteur de couvercle supérieur (67) détectant si le couvercle supérieur (63b) est ouvert ou fermé, le circuit de commande (19) commandant les moyens d'alarme (18) sur la base de chaque sortie de détection du palpeur de détection d'étiquette (66) et du détecteur de couvercle supérieur (67).

2. Dispositif selon la revendication 1, dans lequel l'étiquette (11) est placée avec l'objet (15) en une seule

pièce à l'endroit prédéterminé (13 ; 63).

3. Dispositif selon la revendication 1 ou 2, dans lequel le tiroir (14) ou le boîtier (63) est composé d'un matériel métallique et un élément magnétique doux (22 ; 72) est pris en sandwich entre l'étiquette (11) et le tiroir (14) ou le boîtier (63).

4. Dispositif selon la revendication 3, dans lequel l'élément magnétique doux (22 ; 72) est composé de ferrite frittée, d'un compact de poudre de ferrite et de liant, ou d'un matériau composite de poudre de métal magnétique doux.

5. Dispositif selon l'une quelconque des revendications 1 à 4, dans lequel le palpeur de détection d'étiquette (16) a un noyau de ferrite (23a), autour duquel une bobine est enroulée, et au moins une partie du noyau (23a), qui ne se trouve pas en face de l'étiquette (11), est couverte avec la bobine (23b) par l'un ou l'autre d'un absorbeur d'ondes (26) ou d'un élément de blindage d'ondes électromagnétiques ou par les deux.

6. Dispositif selon la revendication 5, dans lequel une paire de sections de bras (23c, 23d) réalisées en ferrite est prévue aux deux extrémités du noyau (23a) de manière qu'elles font saillie vers l'étiquette (11).

7. Dispositif selon l'une quelconque des revendications 1 à 6, dans lequel le palpeur de détection d'étiquette (66) comprend une antenne cadre (73), et une surface de l'antenne cadre (73), qui ne se trouve pas en face de l'étiquette (11), est couverte par l'un ou l'autre d'un absorbeur d'ondes (26) ou d'un élément de blindage d'ondes électromagnétiques ou par les deux.

8. Dispositif selon l'une quelconque des revendications 1 à 7, dans lequel un circuit d'administration automatique (81 ; 91), qui détecte un fonctionnement anormal d'une étiquette (11), du palpeur de détection d'étiquette (16 ; 66) ou du détecteur de tiroir (17), est prévu.

FIG. 1

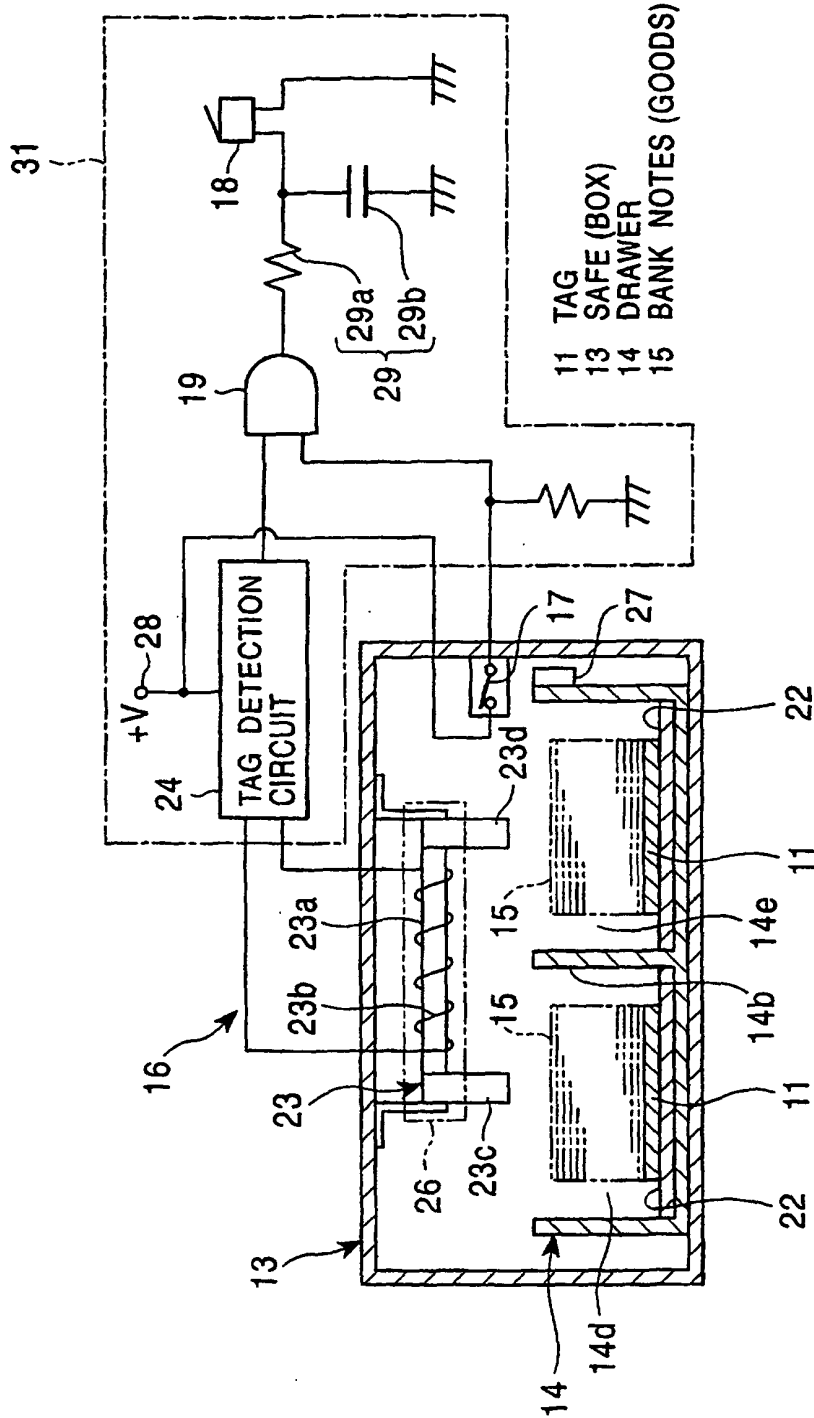

- 16 TAG DETECTION SENSOR
- 17 REED SWITCH (DRAWER SENSOR)
- 18 FIRST BUZZER (ALARM MEANS)
- 19 AND CIRCUIT (CONTROL CIRCUIT)
- 22 SOFT MAGNETIC MEMBER

- 23a CORE
- 23b COIL
- 23c, 23d ARMS
- 26 WAVE ABSORBER

- 11 TAG
- 13 SAFE (BOX)
- 14 DRAWER
- 15 BANK NOTES (GOODS)

FIG. 2A

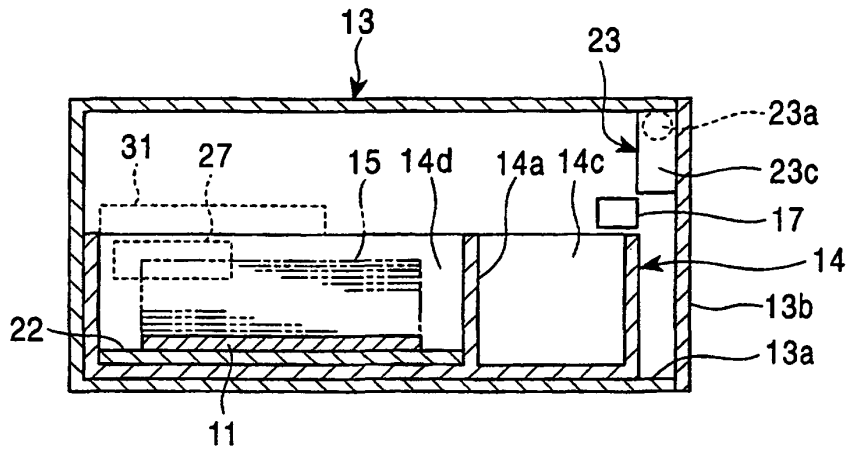

FIG. 2B

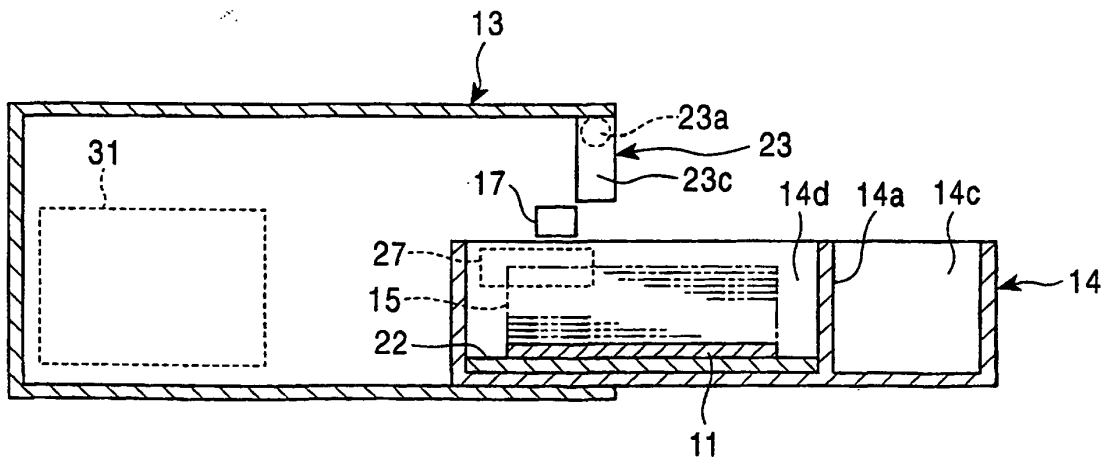

FIG. 3

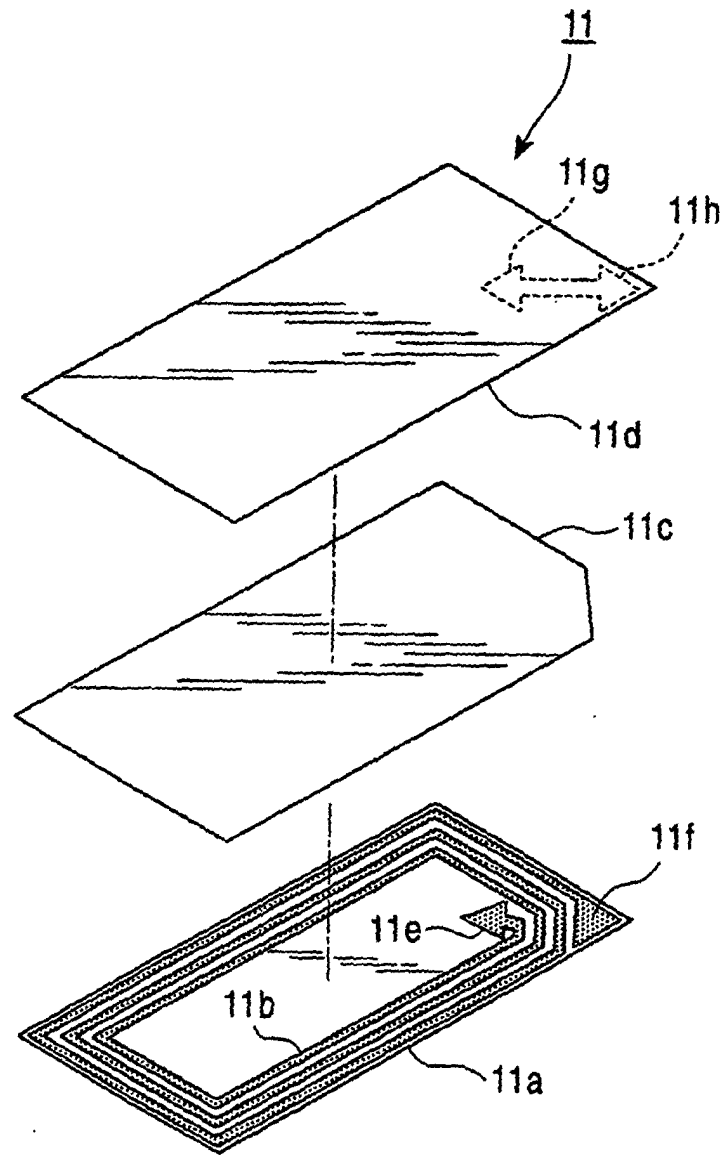

FIG. 4

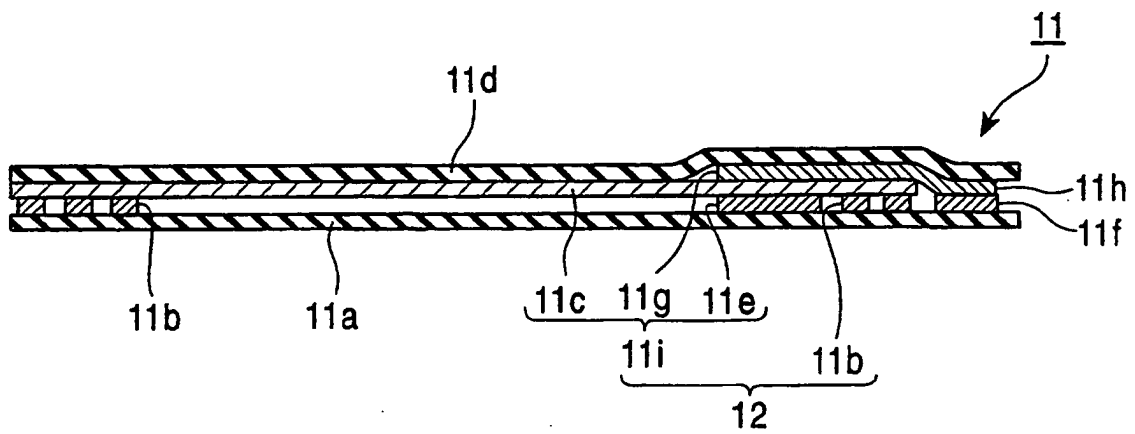

FIG. 5

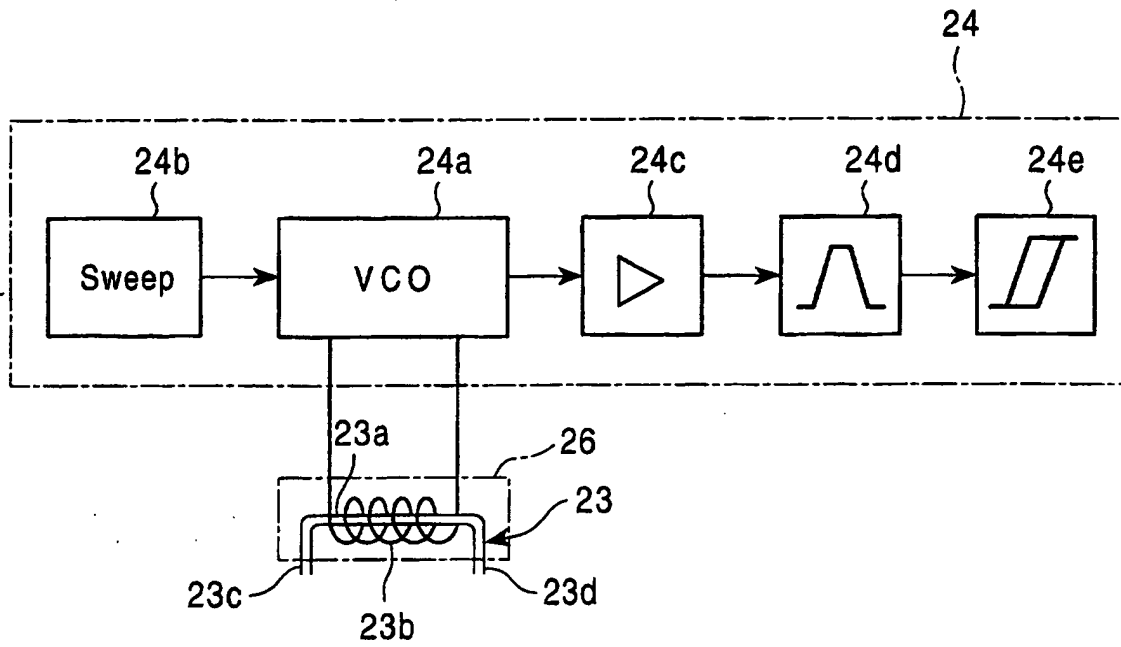
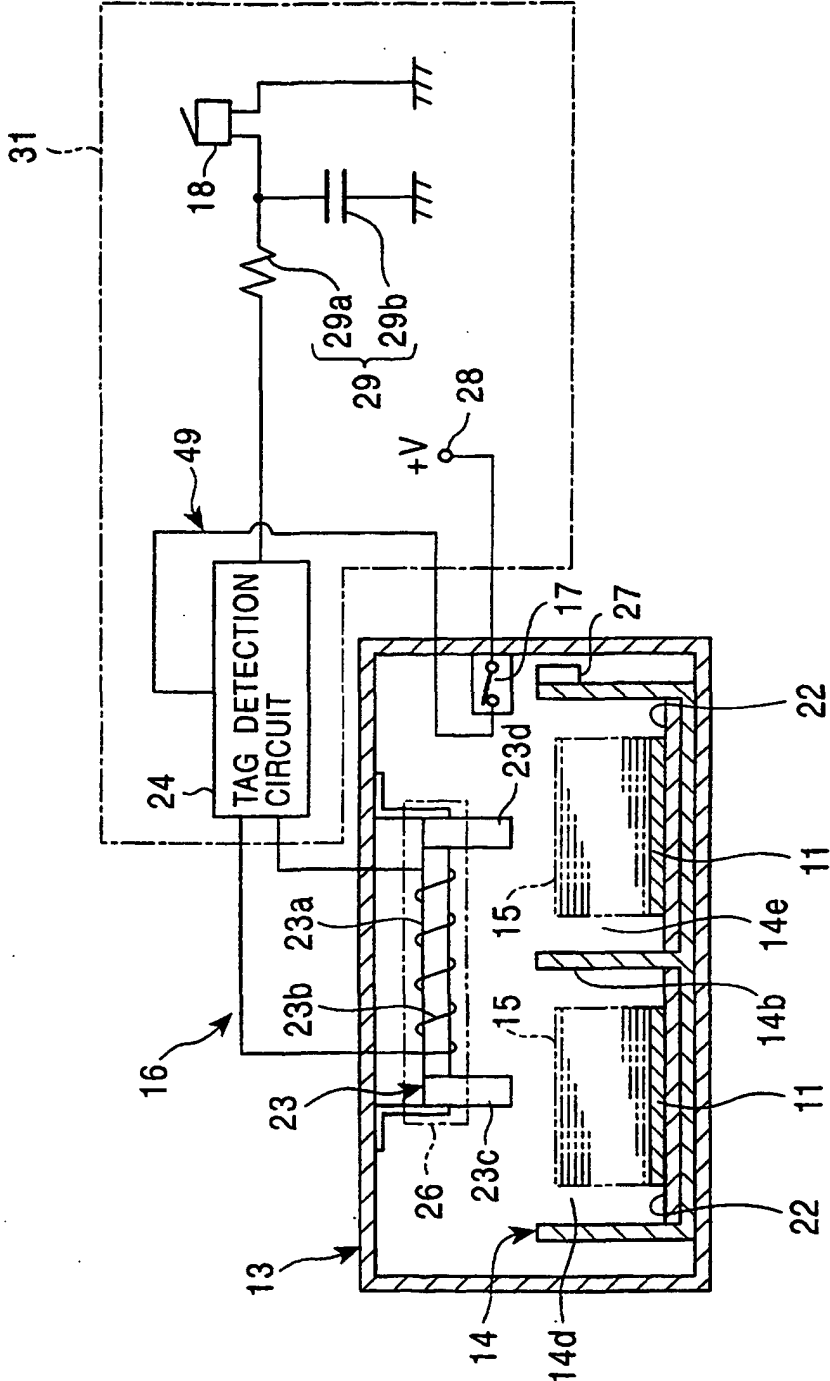
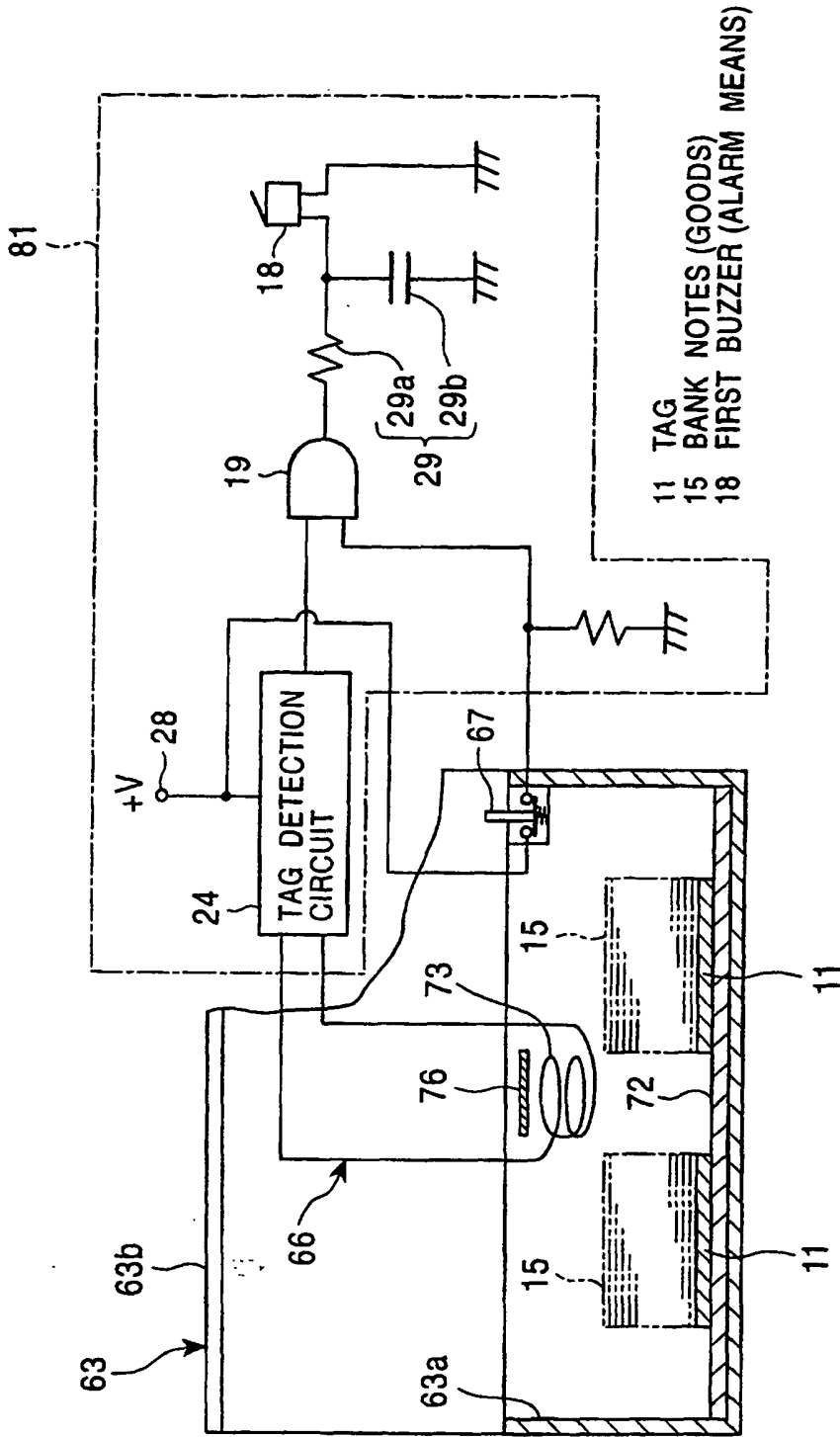

FIG. 6



- 11 TAG
- 13 SAFE (BOX)
- 14 DRAWER
- 15 BANK NOTES (GOODS)
- 16 TAG DETECTION SENSOR
- 17 REED SWITCH (DRAWER SENSOR)
- 18 FIRST BUZZER (ALARM MEANS)
- 22 SOFT MEGNETIC MEMBER
- 23a CORE
- 23b COIL
- 23c, 23d ARMS
- 26 WAVE ABSORBER
- 49 CONTROL CIRCUIT

FIG. 7



- 11 AND CIRCUIT (CONTROL CIRCUIT)
- 15 SAFE (BOX)
- 18 UPPER LID
- 19 TAG DETECTION SENSOR
- 24 TAG DETECTION CIRCUIT
- 28 +V
- 29 AND CIRCUIT (CONTROL CIRCUIT)
- 29a AND CIRCUIT (CONTROL CIRCUIT)
- 29b AND CIRCUIT (CONTROL CIRCUIT)
- 33 AND CIRCUIT (CONTROL CIRCUIT)
- 34 AND CIRCUIT (CONTROL CIRCUIT)
- 35 AND CIRCUIT (CONTROL CIRCUIT)
- 36 AND CIRCUIT (CONTROL CIRCUIT)
- 37 AND CIRCUIT (CONTROL CIRCUIT)
- 38 AND CIRCUIT (CONTROL CIRCUIT)
- 39 AND CIRCUIT (CONTROL CIRCUIT)
- 40 AND CIRCUIT (CONTROL CIRCUIT)
- 41 AND CIRCUIT (CONTROL CIRCUIT)
- 42 AND CIRCUIT (CONTROL CIRCUIT)
- 43 AND CIRCUIT (CONTROL CIRCUIT)
- 44 AND CIRCUIT (CONTROL CIRCUIT)
- 45 AND CIRCUIT (CONTROL CIRCUIT)
- 46 AND CIRCUIT (CONTROL CIRCUIT)
- 47 AND CIRCUIT (CONTROL CIRCUIT)
- 48 AND CIRCUIT (CONTROL CIRCUIT)
- 49 AND CIRCUIT (CONTROL CIRCUIT)
- 50 AND CIRCUIT (CONTROL CIRCUIT)
- 51 AND CIRCUIT (CONTROL CIRCUIT)
- 52 AND CIRCUIT (CONTROL CIRCUIT)
- 53 AND CIRCUIT (CONTROL CIRCUIT)
- 54 AND CIRCUIT (CONTROL CIRCUIT)
- 55 AND CIRCUIT (CONTROL CIRCUIT)
- 56 AND CIRCUIT (CONTROL CIRCUIT)
- 57 AND CIRCUIT (CONTROL CIRCUIT)
- 58 AND CIRCUIT (CONTROL CIRCUIT)
- 59 AND CIRCUIT (CONTROL CIRCUIT)
- 60 AND CIRCUIT (CONTROL CIRCUIT)
- 61 AND CIRCUIT (CONTROL CIRCUIT)
- 62 AND CIRCUIT (CONTROL CIRCUIT)
- 63 AND CIRCUIT (CONTROL CIRCUIT)
- 64 AND CIRCUIT (CONTROL CIRCUIT)
- 65 AND CIRCUIT (CONTROL CIRCUIT)
- 66 AND CIRCUIT (CONTROL CIRCUIT)
- 67 AND CIRCUIT (CONTROL CIRCUIT)
- 68 AND CIRCUIT (CONTROL CIRCUIT)
- 69 AND CIRCUIT (CONTROL CIRCUIT)
- 70 AND CIRCUIT (CONTROL CIRCUIT)
- 71 AND CIRCUIT (CONTROL CIRCUIT)
- 72 AND CIRCUIT (CONTROL CIRCUIT)
- 73 AND CIRCUIT (CONTROL CIRCUIT)
- 74 AND CIRCUIT (CONTROL CIRCUIT)
- 75 AND CIRCUIT (CONTROL CIRCUIT)
- 76 AND CIRCUIT (CONTROL CIRCUIT)
- 77 AND CIRCUIT (CONTROL CIRCUIT)
- 78 AND CIRCUIT (CONTROL CIRCUIT)
- 79 AND CIRCUIT (CONTROL CIRCUIT)
- 80 AND CIRCUIT (CONTROL CIRCUIT)
- 81 AND CIRCUIT (CONTROL CIRCUIT)

FIG. 8A

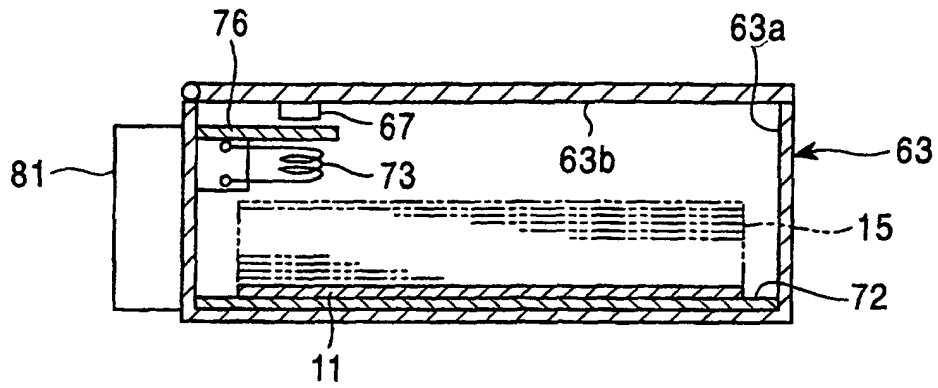

FIG. 8B

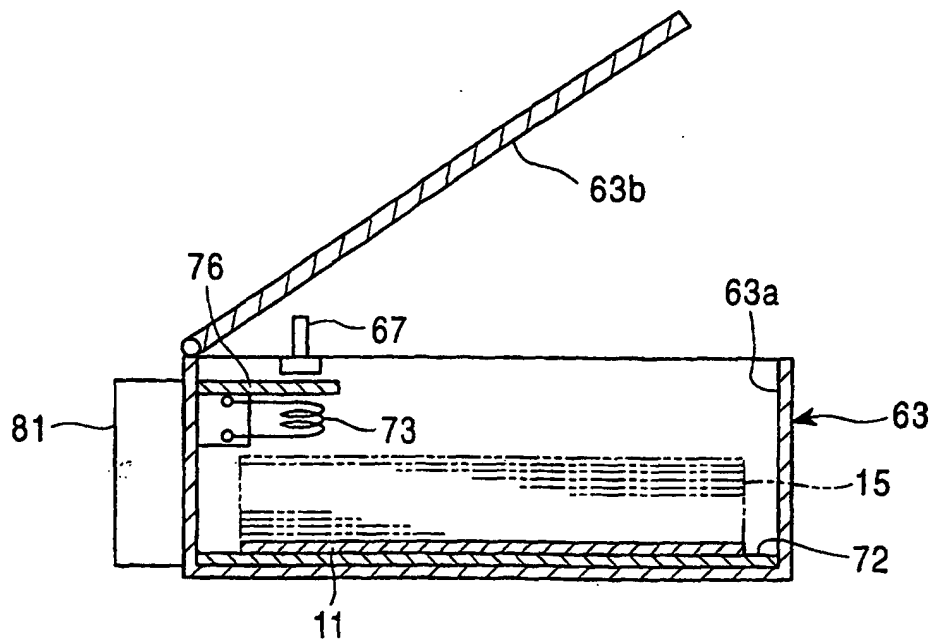
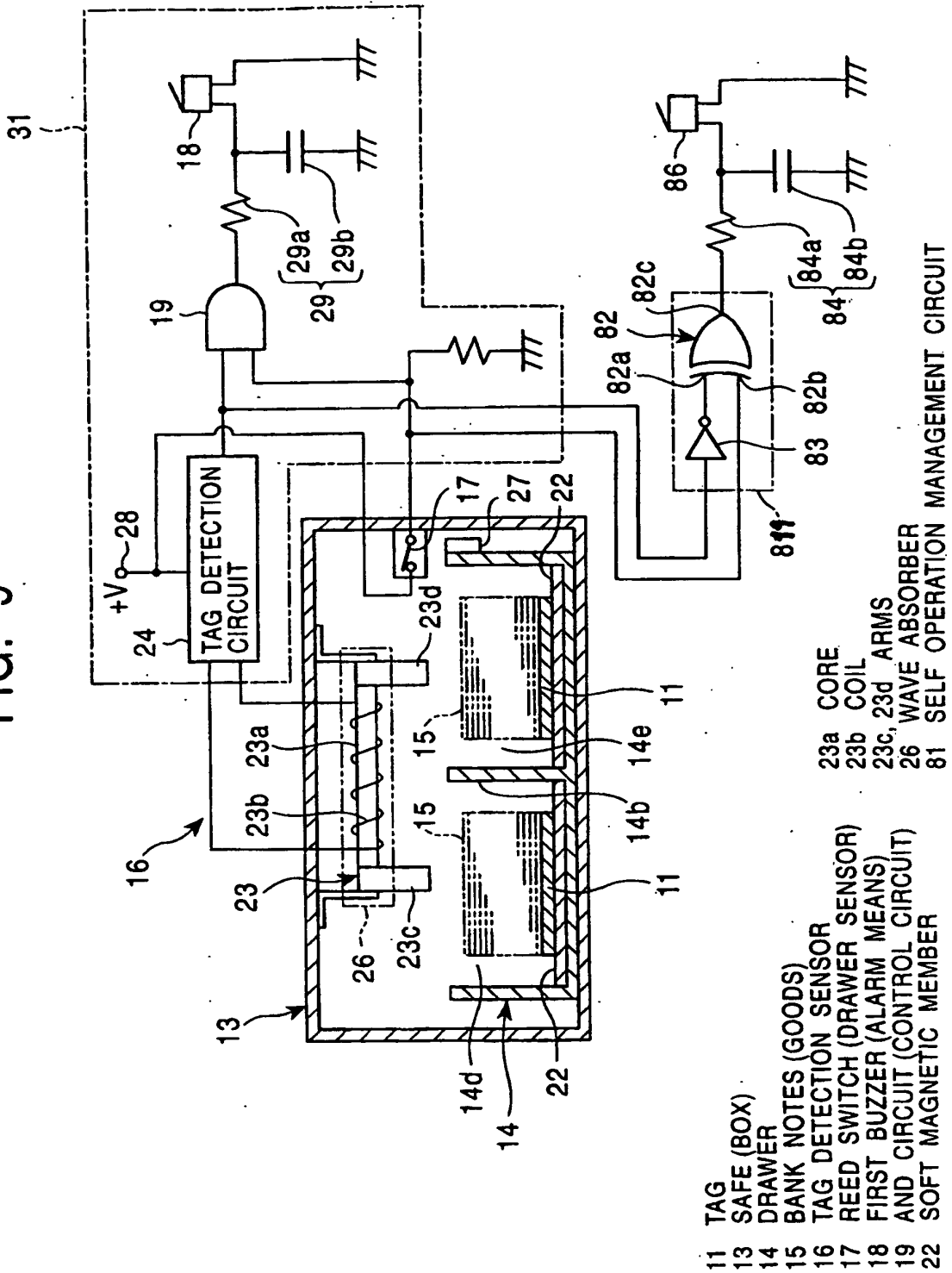
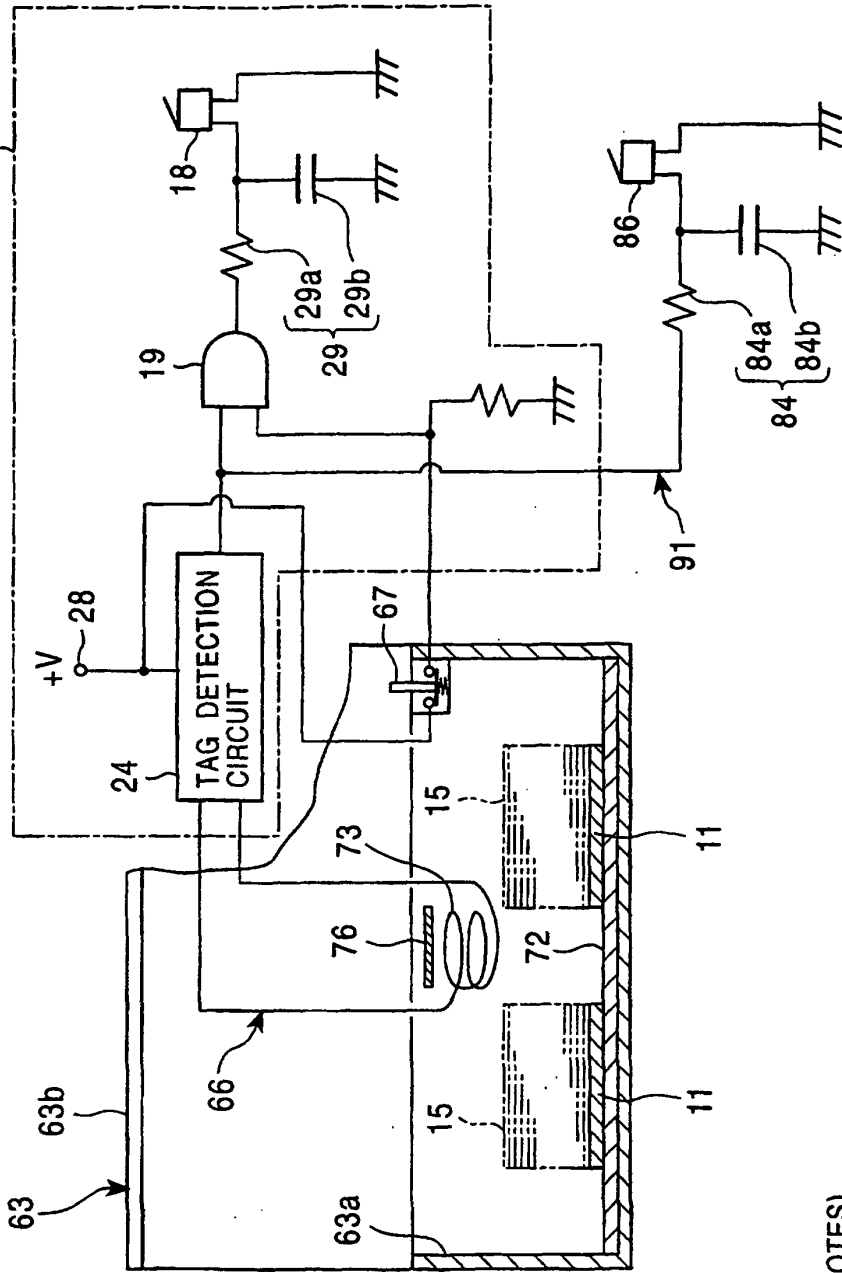

FIG. 9



- 11 TAG
- 13 SAFE (BOX)
- 14 DRAWER
- 15 BANK NOTES (GOODS)
- 16 TAG DETECTION SENSOR
- 17 REED SWITCH (DRAWER MEANS)
- 18 FIRST BUZZER (ALARM MEANS)
- 19 AND CIRCUIT (CONTROL CIRCUIT)
- 22 SOFT MAGNETIC MEMBER
- 23a CORE
- 23b COIL
- 23c, 23d ARMS
- 26 WAVE ABSORBER
- 81 SELF OPERATION MANAGEMENT CIRCUIT

FIG. 10



- 11 TAG
- 15 BANK (NOTES)
- 18 FIRST BUZZER (ALARM MEANS)
- 19 AND CIRCUIT (CONTROL CIRCUIT)
- 63 SAFE (BOX)
- 63a UPPER LID
- 66 TAG DETECTION SENSOR
- 67 MICRO SWITCH (UPPER LID SWITCH)

- 72 SOFT MAGNETIC MEMBER
- 73 LOOP ANTENNA
- 76 WAVE ABSORBER
- 91 SELF OPERATION MANAGEMENT CIRCUIT