



(11) **EP 0 938 863 B1**

(12) **EUROPEAN PATENT SPECIFICATION**

(45) Date of publication and mention of the grant of the patent:  
**11.04.2007 Bulletin 2007/15**

(51) Int Cl.:  
**A47L 13/256<sup>(2006.01)</sup> A47L 13/20<sup>(2006.01)</sup>**

(21) Application number: **99660038.3**

(22) Date of filing: **25.02.1999**

(54) **Cleaning device, cleaning cloth and method of cleaning**

Reinigungsgerät, Reinigungstuch und Verfahren zum Reinigen

Ustensile de nettoyage, tissu de nettoyage et méthode de nettoyage

(84) Designated Contracting States:  
**AT BE CH CY DE DK ES FI FR GB GR IE IT LI LU  
MC NL PT SE**

(30) Priority: **27.02.1998 FI 980453**

(43) Date of publication of application:  
**01.09.1999 Bulletin 1999/35**

(73) Proprietor: **SAPPAX OY  
25470 Kisko (FI)**

(72) Inventor: **Heinonen, Aaro  
. (FI)**

(74) Representative: **Kärkkäinen, Veli-Matti et al  
Borenus & Co Oy Ab  
Tallberginkatu 2 A  
00180 Helsinki (FI)**

(56) References cited:  
**CH-A- 263 480 DE-A- 1 703 505  
US-A- 1 946 321 US-A- 5 477 582**

**EP 0 938 863 B1**

Note: Within nine months from the publication of the mention of the grant of the European patent, any person may give notice to the European Patent Office of opposition to the European patent granted. Notice of opposition shall be filed in a written reasoned statement. It shall not be deemed to have been filed until the opposition fee has been paid. (Art. 99(1) European Patent Convention).

**Description**FIELD OF THE INVENTION

**[0001]** The present invention relates to a cleaning device for cleaning surfaces, such as floors, walls, windows, doors, tables, roofs, etc. The invention relates also to a method of cleaning.

BACKGROUND OF THE INVENTION

**[0002]** A widely used prior art solution in cleaning surfaces is to use a mop supported by a supporting framework or similar support portion of a cleaning device. The mop is fixedly attached, i.e. arranged in a non-movable relation to the framework during sweeping of e.g. a floor surface. The mop can be made of suitable material, such as cotton, felt, or artificial fibres. Various solutions for the sweeping mops and for the attachment thereof are known e.g. from US patents Nos. 3,029,454, 3,711,886, 4,715,081 and 4,914,778 or from FI patents Nos. 68514 and 88670 and FI patent applications Nos. 955346 and 961107. In all of these the size and form of the mop cloth corresponds substantially the size and shape of the supporting framework. Said mop can also be provided with "yarns" or the like extending from the edges of the mop cloth.

**[0003]** US patent 1,946,321 discloses a cleaning device comprising a stem and a cleaning cloth forming a roll, which has a plurality of exposable cleaning surfaces that can be removed when used. US patent 5,042,105 discloses a terry cloth cover for a clamp on sponge mop.

**[0004]** US patent 5,542,143 in turn discloses a cleaning device in which a water absorbing member is movably assembled in relation to the body portion of the device. In this a circularly cleaning swab structure is mainly composed of a grip stem, a casing and an annular water-absorbing member, wherein the casing is connected at the lower end of the grip stem and defines an interior close water-containing room. The water-absorbing member is disposed around outer periphery of the casing and formed with inner engaging teeth for engaging with corresponding teeth of a rotary wheel rotatably disposed on an outer lateral side of the casing. A top portion of the water-absorbing member is inserted within a clearance defined between the casing and a upper cover of the casing while a bottom portion of the water-absorbing member is located under a bottom of the casing for contacting the ground. The arrangement is such that after swabbing the ground, the contaminated bottom portion of the water-absorbing member can be one-way circularly driven into the interior of the casing to be soaked into a detergent or a liquid and squeezed.

SUMMARY OF THE INVENTION

**[0005]** The prior art arrangements have some disadvantages. The non-movable solution do not allow an ef-

ficient use of the entire surface area of the mop cloth for the cleaning, but they are arranged to sweep only by the lower or bottom side thereof. Due to the fact that the mop becomes dirty from the lower surface during the sweeping it has to be frequently removed from the supporting framework and washed, or then it has to be replaced by a clean mop. This causes breaks to the actual sweeping operation, or a need to use more than one mop for the sweeping. The washing devices or arrangements and/or amount of replacement mops increases the total costs of the cleaning work, and makes the overall control and management of the required cleaning equipment and material more complicated.

**[0006]** A problem relies also in the fact that in connection with prior art solutions several different cleaning means, such as separate dust sweeping arrangements, washing cloths and drying devices, are required. The transportation and carrying of various separate cleaning means makes the cleaning work more difficult. The separate devices are expensive to purchase and increase further the above mentioned problems related to the control and management of the cleaning equipment.

**[0007]** Even though US patent 5,542,143 discloses a movable annular water absorbing member, it does not provide any appropriate means for providing an increased sweeping surface, but provides only a narrow sweeping surface area. In addition, the device and the water absorbing member thereof can be used only for the purpose of washing surfaces.

**[0008]** It is an object of the present invention to overcome the disadvantages of the prior art solutions and to provide a new type of solution for cleaning apparatus and method of cleaning.

**[0009]** A further object of the present invention is to provide a method and arrangement in which the cleaning cloth means need to be changed less frequently as is the case with the prior art mop clothes.

**[0010]** A further object of the present invention is to provide a method and arrangement in which the available sweeping surface area of the mop is substantially larger than in the known solutions.

**[0011]** A further object of the present invention is to provide a cleaning device for multipurpose use. An additional object is an apparatus and a method by means of which the washing and subsequent sweeping can be accomplished by a single device.

**[0012]** A further object of the present invention is to provide a cleaning device in which the sweeping cloth is attached in a new manner relative to the frame of the device.

**[0013]** According to a first aspect the objects are obtained by a cleaning device comprising the features according to claim 1.

**[0014]** The cleaning device comprises means for holding the cleaning cloth in its position in engagement with the body portion. Said holding means may consist of a biased spring element attached to the support portion. The arrangement is then such that the cleaning cloth loop

can be moved relative to the support portion only in case the spring element is in its opened position. The stem portion is preferably attached to the spring element, wherein the spring element is arranged to be opened by means of the stem portion. According to one alternative the elongated support portion consist of a bar attached from the other end thereof to a body portion of the cleaning device and extending substantially parallel with the body portion. The bar can be of hollow construction and provided with a longitudinally extending slot for receiving a cloth holding bulb into the bar. According to a still further embodiment a cleaning device comprises two sweeping blades, the blades extending in parallel with the support portion, wherein the sweeping edge of the first blade is arranged to sweep in a first direction of cleaning movement and the sweeping edge of the second blade is arranged to sweep in a second direction of cleaning movement. The bar may extend between the two blades.

**[0015]** According to a second aspect the invention provides a method of cleaning comprising the features according to claim 9.

**[0016]** Remarkable advantages are obtained by means of the present invention. These include, for instance, a possibility to reduce the amount of different kinds of cleaning clothes or fabrics and also the amount of cleaning cloth changes. These have a positive effect on the costs of the cleaning work. In addition, it is possible to reduce the amount of different kind of equipment needed in the cleaning, since the same cleaning device can be used both for the washing and the subsequent drying or finishing sweeping. Since the same cleaning device can be used for several different work stages, it is possible to easily combine interface the work stages, whereby the overall duration of the cleaning work can be shortened. The invented cleaning device provides many-sided properties and can be used for instance as a means for cleaning floors or a window cleaner.

**[0017]** In the following the present invention and the other objects and advantages thereof will be described in an exemplifying manner with reference to the annexed drawings, in which similar reference characters throughout the various figures refer to similar features. It is noted herein that the term cleaning refers widely to all such operations in which surfaces are swept, washed, polished or otherwise treated for the purposes of cleaning, polishing, protecting etc.

#### BRIEF DESCRIPTION OF THE DRAWINGS

##### **[0018]**

Figures 1a and 1b disclose a schematic side views of cleaning devices in accordance with the present invention;

Figure 2 discloses an end view of the figure 1a device and a cleaning cloth supported by it;

Figure 3 is similar to figure 2, but discloses another possibility of mounting the cleaning cloth;

Figures 4a and 4b disclose some ways to use the solution of figure 3; and

Figure 5 discloses a further embodiment.

#### 5 DETAILED DESCRIPTION OF THE DRAWINGS

**[0019]** Figure 1a discloses one elongated cleaning cloth support or holder frame 10 of cleaning device in accordance with the invention. A corresponding cleaning device is disclosed in figure 2 as seen from the left end thereof and provided with a looped cleaning cloth or fabric 9.

**[0020]** The support comprises a body portion 6 provided with slots 12 which receive special sweeping blades or lips 7. The body portion 6 can be made e.g. from steel, aluminium, plastics or the like material suitable for this purpose. The sweeping blades 7 can be made e.g. from rubber, plastic or foamed plastic, or then they can be formed by means of suitable brushes. The sweeping blades 7 can be provided, if desired, with sharp sweeping or drying edges. The blades are threaded into their position within the slots 12 of the body portion 6 from the other end of the body portion 6 in a per se known manner. It is noted herein that it is possible to have only one blade instead of two blades, and that the blade or lip 7 is not the essential part of the invention, but that the invention can also be implemented without any blades, as will be described later.

**[0021]** A spring element 4 has been attached by screws 5 on top of the body portion 6. The spring element 4 is biased such that it slightly bears against the upper surface of the body 6. It can be lifted off from the body surface, i.e. is movable relative to the body portion 6 in a manner illustrated by the two-headed arrow. The spring element 4 can be made from a spring steel level rod, as is the case in figures 1a and 2, or e.g. from a suitably formed spring wire structure. Various suitable spring elements for providing the biased holding of the cleaning cloth which can be utilised in the invention are well known by the skilled person, and will thus not be explained in more detail.

**[0022]** An attachment pivot structure 2 of the stem portion 1 is mounted on the upper side of the free end of the spring element 4 by means of screws 3. The stem 1 is shown only partially, but the skilled person understands that it can be of any suitable length, such as between 0,5 to 1,5 meters long. The stem 1 and the pivot structure 2 enabling a pivoting attachment of the stem 1 to the body portion 6 can be of any known type, e.g. any of the solutions disclosed in the above referred prior art publications.

**[0023]** Figure 1b corresponds otherwise figure 1a, but discloses an embodiment in which the elongated cleaning cloth support 10 is of an essentially long structure. In such case it may occur that the biasing force of the spring element 4 is not sufficient enough. In such case the spring element 4 can be locked from the free end thereof to the body 6 by means of a clamp or locking device 14. The

clamp can be of any appropriate type providing releasable locking.

**[0024]** Figure 2 discloses an embodiment in which a cleaning cloth 9 has been threaded to cover the body portion 6. The cleaning cloth 9 is annular, i.e. has a shape of an endless loop, and is arranged to be threaded around a support portion of the cleaning device support frame 10 through an opening in the other side edge of the loop. The material of the cleaning cloth 9 can consist of any appropriate material used for cleaning cloths in general, such as clothes made from cotton, terry, felt, microfibers, artificial fibers, woven linen, etc. It is also possible to turn the looped cloth 9 around, i.e. inside up, so that utilisation of both sides of the loop is enabled.

**[0025]** As disclosed by figure 2, the sweeping cloth 9 is threaded to surround the supporting body portion 6 through the other end opening thereof and is placed to lie under the spring element 4 so as to be held in its desired position by means of the spring element. Therefore the cloth 9 remains steadily in its position during the cleaning procedures. When a need to move i.e. "rotate" the cloth 9 relative to the support body 6 arises, the spring element 4 is lifted off from the body surface, e.g. by means of lifting the stem 1 as illustrated by the arrows in figures 1a and 1b. By rotating the cloth 9 it is possible to obtain a clean or dry portion of the cloth against the surface to be swept, whereas the dirty or wet portion of the cloth is placed on the top side, i.e. in a position where it is not in use and cannot touch the surface. By means of the solution it is possible to utilise the entire surface area of the cloth 9 from both sides thereof (i.e. both the inner and outer surface of the loop) which has a positive effect to both the overall duration time of the cleaning (smaller need for changing and/or washing or drying the cleaning cloth) and the costs for the cleaning equipment (smaller amount of cleaning clothes is required).

**[0026]** According to the alternative disclosed by figure 3 the looped cleaning cloth 9 is adapted to be attached to the cleaning device by threading the looped cloth around a bar means 8 extending below the body portion 6 from the other end 11 thereof. As illustrated by figure 3, the bar means 8 can be fixed to an end plate 11 provided in the other end of the body 6.

**[0027]** A difference to the solution of figure 2 is that now it is possible to use the blade 7, and more precisely the sharp edge, for sweeping or drying the surface when this is desired. In the embodiment of figure 2 the blades 7 provide bearing support for the cleaning cloth as it is pushed against the surface to be cleaned. In case a need to use the edge of the blade arises, the cloth 9 has to be removed around the body portion 6.

**[0028]** Figures 4a and 4b illustrate the use of the figure 3 arrangement. As can be noted from figure 4a, only the other of the blades 7 is used to bear the cloth 9 against the surface (not shown) whereas the other blade remains free. This other blade can be utilised for precleaning of the surface, for example for cleaning away stones etc. small particles or rubbish which otherwise would enter

into the cleaning cloth 9. In figure 4b the cloth 9 is swung around the body portion 6, whereby it is possible to use the other of the blades 7 for e.g. drying purposes. This solution provides advantage e.g. when washing windows, since only one device is needed which can be used both for the washing (by means of the replaceable / rotatable cloth 9) and for drying by mean of the blade 7.

**[0029]** According to one embodiment the bar means 8 and the slot between at least the other of the blades 7 is arranged to be substantially narrow, or even such that the blade 7 bears against the bar means 8. This provides a corresponding holding effect as what is achieved by means of the spring element 4.

**[0030]** The bar means 8 may also be provided with a slot or opening extending over the entire length thereof, whereby the bar means 8 form a C-shaped structure. A cleaning cloth can be threaded into this kind of structure, said cleaning cloth being provided with a special retaining bulb, such as a narrow rod etc. sewed within the cleaning cloth. The bulb is threaded inside the bar means 8 such that it becomes retained by the bar means.

**[0031]** Figures 1 to 4 disclose an elongated cleaning cloth support 10 which is provided with two blades 7 which in turn are provided with drying tips or edges. In addition to the sweeping and/or scraping properties, these blades can be utilised in the actual cleaning operation, as they can be used as elements bearing the cloth against the surface to be cleaned. Some advantages are obtained in the cleaning by bearing by means of the disclosed blade e.g. due to reason that the surface area by which the cloth or fabric is pressed against the surface to be cleaned remains essentially narrow while the pressure against the surface to be cleaned can be held in a substantially high level. For instance, a wet cloth slides easily on the surface while the cleaning effect thereof is at its highest level.

**[0032]** As can be seen from figure 4a, the left hand side blade 7 bears the cloth against the surface while the device is moved to the right. The remaining part of the cloth follows the support device, and it can absorb / dry any water left behind on the surface while the device is forwarded.

**[0033]** Figure 5 discloses one additional embodiment. In this the body portion 6 is provided to have a substantially flat structure. A cleaning cloth 29 used in this has a looped shape, but now such that the other end thereof is closed. The open end of the cloth is threaded through the opening 30, as disclosed by arrow, to surround the body frame 6. A flap or loop 31 can be used when drawing the cloth loop around the body 6. When the cleaning cloth 29 is completely threaded to surround the body portion 6, a spring element 4 is released so that it may bear against the body portion 6 and retain the cloth in its position. It is possible to provide the flap portion 31 with suitable means for attachment and the surface of the end of the cloth 29 with appropriate counterparts so that the flap portion can also be utilised in closing the end opening 30 and in holding the cleaning cloth 29 around the support

frame 6.

**[0034]** It is to be noted that the cleaning device in accordance with the present invention can be intended for sweeping floor or roof surfaces or similar, in which case the stem portion is provided by means of a substantially long pivoted stem, or then a hand held cleaning device in which the stem portion is provided by means of a substantially short stem with no pivoting parts or similar short hand grip, for cleaning e.g. windows or table surfaces.

**[0035]** Thus, the invention provides an apparatus and a method by which a significant improvement can be achieved in cleaning work. It should be noted that the foregoing examples of the embodiments of the invention are not intended to restrict the scope of the invention to the specific forms presented above but the present invention is meant rather to cover all modifications, similarities and alternatives which are included in the scope of the present invention, as defined by the appended claims.

### Claims

1. A cleaning device comprising a stem portion (1) and an elongated support portion (6) connected thereto for supporting a cleaning cloth, the direction of said support portion being located in a plane normal to the direction of the main cleaning movement, when said device is in use,  
**characterized by**  
an endless, sleeve-like cleaning cloth forming a continuous loop (9) arranged to be threaded via an opening in one end thereof, around the elongated support portion (6)  
said cleaning device further comprising a holding means (4) for providing biased holding of the cleaning cloth (9) in its position, wherein said holding means (4) is in turn, attached to said elongated support portion (6), so that when in use, said endless cleaning cloth loop (9) is adapted to be rotatable around the longitudinal axis of said elongated support portion (6).
2. A cleaning device according to claim 1, **characterized in that** it further comprises means for holding the cleaning cloth (9) in its position in engagement with the elongated support portion (6), said holding means consisting of a biased spring element (4) attached to the elongated support portion (6), said spring element biasing against the support portion, wherein the arrangement is such that the cleaning cloth loop (9) can be moved relative to the elongated support portion (6) only in case the spring element (4) is in its opened position.
3. A cleaning device according to claim 2, **characterized in that** the stem portion (1) is attached to the spring element (4), wherein the spring element is

arranged to be opened by means of the stem portion.

4. A cleaning device according to claims 2 or 3, **characterized by** further comprising a locking member (14) for locking the spring element (4) to a position clamping the cloth.
5. A cleaning device according to claim 1, **characterized in that** the elongated support portion consist of a bar (8) attached from the other end thereof to an elongated support portion (6) of the cleaning device (10) and extending substantially parallel with the elongated support portion.
6. A cleaning device according to claim 5, **characterized in that** the bar (8) is of hollow construction and provided with a longitudinally extending slot for receiving a cloth holding bulb into the bar.
7. A cleaning device according to any of claims 1 to 6, **characterized in that** it comprises two sweeping blades (7), the blades extending in parallel with the elongated support portion (6), wherein the sweeping edge of the first blade (7) is arranged to sweep in a first direction of cleaning movement and the sweeping edge of the second blade (7) is arranged to sweep in a second direction of cleaning movement.
8. A cleaning device according to claim 7, **characterized in that** the bar (8) extends between the two blades (7).
9. A method of cleaning, utilizing the device of claim 1, wherein:  
  
the endless sleeve-like cleaning cloth (9) is arranged to be threaded via an opening in one end thereof, around the elongated support portion (6) and held there against by the bias of a holding means, so that in use, said endless looped cleaning cloth is adapted to be rotated about the longitudinal axis of said elongated support means
10. A method in accordance with claim 10, **characterized in that** the looped cleaning cloth (9) is held in the position by means of a biased spring element (4) bearing against the elongated support portion (6), and that the biasing force is removed by pulling the spring element (4) off from the elongated support portion (6) by means of the stem portion (1) attached to the spring element.

### 55 Patentansprüche

1. Reinigungsvorrichtung mit einem Stielteil (1) und einem mit diesem verbundenen, langgestreckten

- Stützteil (6), das einen Reinigungsbezug (9) trägt und das in einer Ebene ausgerichtet ist, die bei Benutzung der Reinigungsvorrichtung senkrecht zur Richtung der Hauptreinigungsbewegung steht, **dadurch gekennzeichnet, dass** ein endloser, hüllenartiger Reinigungsbezug vorgesehen ist, der eine ununterbrochene Schleife bildet, die derart ausgebildet ist, dass sie über eine Öffnung an einem Schleifenende auf den langgestreckten Stützteil (6) aufgezogen werden kann und dass die Reinigungsvorrichtung ferner ein Haltemittel (4) aufweist, das den Reinigungsbezug (9) in seiner Position unter Spannung hält und selbst am langgestreckten Stützteil (6) befestigt ist, so dass beim Gebrauch die endlose Schleife des Reinigungsbezugs (9) derart angepasst ist, dass sie um die Längsachse des langgestreckten Stützteils (6) drehbar ist.
2. Reinigungsvorrichtung nach Anspruch 1, **dadurch gekennzeichnet, dass** das Haltemittel (4) mit dem langgestreckten Stützteil (6) derart zusammenwirkt, dass es den Reinigungsbezug (9) in dessen Position festhält, und dass das Haltemittel (4) aus einem am langgestreckten Stützteil (6) befestigten, gegen den Stützteil vorgespannten Federelement besteht, wobei diese Anordnung derart ausgebildet ist, dass die Schleife des Reinigungsbezugs (9) gegenüber dem langgestreckten Stützteil (6) nur dann bewegt werden kann, wenn sich das Federelement in seiner offenen Stellung befindet.
3. Reinigungsvorrichtung nach Anspruch 2, **dadurch gekennzeichnet, dass** der Stielteil (1) am Federelement befestigt ist, wobei das Federelement derart ausgebildet ist, dass es durch den Stielteil geöffnet werden kann.
4. Reinigungsvorrichtung nach Anspruch 2 oder 3, **dadurch gekennzeichnet, dass** sie ferner eine Feststellvorrichtung (14) zum Feststellen des Federelements in eine Position enthält, in der der Reinigungsbezug (9) eingeklemmt ist.
5. Reinigungsvorrichtung nach Anspruch 1, **dadurch gekennzeichnet, dass** das langgestreckte Stützteil (6) eine Schiene (8) aufweist, die am anderen Stützteilende am langgestreckten Stützteil (6) der Reinigungsvorrichtung (10) befestigt ist und sich im Wesentlichen parallel zum langgestreckten Stützteil (6) erstreckt.
6. Reinigungsvorrichtung nach Anspruch 5, **dadurch gekennzeichnet, dass** die Schiene (8) hohl ausgebildet und mit einem in Längsrichtung verlaufenden Schlitz versehen ist, in den eine den Reinigungsbezug in der Schiene haltende Wulst eingreift.
7. Reinigungsvorrichtung nach einem der Ansprüche 1 bis 6, **dadurch gekennzeichnet, dass** sie zwei Kehrblätter (7) aufweist, die parallel zum langgestreckten Stützteil (6) verlaufen, wobei die Kehrkante des ersten Kehrblatts (7) derart ausgebildet ist, dass sie in einer ersten Richtung der Reinigungsbewegung kehrt, und die Kehrkante des zweiten Kehrblatts (7) derart ausgebildet ist, dass sie in einer zweiten Richtung der Reinigungsbewegung kehrt.
8. Reinigungsvorrichtung nach Anspruch 7, **dadurch gekennzeichnet, dass** die Schiene (8) zwischen den beiden Kehrblättern (7) verläuft.
9. Reinigungsverfahren unter Verwendung der Reinigungsvorrichtung nach Anspruch 1, **dadurch gekennzeichnet, dass** der endlose, hüllenartige Reinigungsbezug (9) derart ausgebildet ist, dass er über eine Öffnung in einem Reinigungsbezugende um den langgestreckten Stützteil (6) aufgezogen werden kann, und am Stützteil mittels der Vorspannung eines Haltemittels gehalten wird, so dass beim Gebrauch die endlose Schleife des Reinigungsbezugs derart angepasst ist, dass sie um die Längsachse des langgestreckten Stützteils drehbar ist.
10. Reinigungsverfahren nach Anspruch 9, **dadurch gekennzeichnet, dass** die Schleife des Reinigungsbezugs (9) mittels eines vorgespannten Federelements, das in Richtung auf den langgestreckten Stützteil (6) drückt, in Position gehalten wird und dass die Vorspannungskraft auf den langgestreckten Stützteil mittels des am Federelement befestigten Stielteils (1) fortgenommen werden kann.

#### Revendications

1. Dispositif de nettoyage comprenant une portion de tige (1) et une portion de support oblongue (6) reliée à celle-ci pour supporter un tissu de nettoyage, la direction de ladite portion de support étant située dans un plan perpendiculaire à la direction du mouvement de nettoyage principal lorsque ledit dispositif est en cours d'utilisation, **caractérisé par** un tissu de nettoyage sans fin, en forme de manchon, formant une boucle continue (9) agencée pour être vissée par une ouverture dans une extrémité de celle-ci, autour de la portion de support oblongue (6), ledit dispositif de nettoyage comprenant en outre un moyen de retenue (4) pour réaliser une retenue sollicitée du tissu de nettoyage (9) dans sa position, où ledit moyen de retenue (4) est à son tour fixé à ladite

- portion de support oblongue (6) de telle sorte qu'en cours d'utilisation, ladite boucle de tissu de nettoyage sans fin (9) est apte à tourner autour de l'axe longitudinal de ladite portion de support oblongue (6). 5
2. Dispositif de nettoyage selon la revendication 1, **caractérisé en ce qu'il** comprend en outre un moyen pour retenir le tissu de nettoyage (9) dans sa position en prise avec la portion de support oblongue (6), ledit moyen de retenue étant constitué d'un élément de ressort sollicité (4) fixé à la portion de support oblongue (6), ledit élément de ressort sollicitant contre la portion de support, où l'agencement est tel que la boucle de tissu de nettoyage (9) peut être déplacée relativement à la portion de support oblongue (6) seulement dans le cas où l'élément de ressort (4) se trouve dans sa position ouverte. 10
3. Dispositif de nettoyage selon la revendication 2, **caractérisé en ce que** la portion de tige (1) est fixée à l'élément de ressort (4), où l'élément de ressort est agencé pour être ouvert par la portion de tige. 20
4. Dispositif de nettoyage selon les revendications 2 ou 3, **caractérisé en** comprenant en outre un élément de verrouillage (14) pour verrouiller l'élément élastique (4) dans une position serrant le tissu. 25
5. Dispositif de nettoyage selon la revendication 1, **caractérisé en ce que** la portion de support oblongue est constituée d'une barre (8) fixée à son autre extrémité à une portion de support oblongue (6) du dispositif de nettoyage (10) et s'étendant sensiblement parallèlement à la portion de support oblongue. 30 35
6. Dispositif de nettoyage selon la revendication 5, **caractérisé en ce que** la barre (8) est d'une construction creuse et présente une fente s'étendant longitudinalement pour recevoir un bulbe de retenue de tissu dans la barre. 40
7. Dispositif de nettoyage selon l'une des revendications 1 à 6, **caractérisé en ce qu'il** comprend deux lames de balayage (7), les lames s'étendant parallèlement à la portion de support oblongue (6), où le bord de balayage de la première lame (7) est agencé pour balayer dans une première direction du mouvement de nettoyage, et le bord de balayage de la seconde lame (7) est agencé pour balayer dans une seconde direction de mouvement de nettoyage. 45 50
8. Dispositif de nettoyage selon la revendication 7, **caractérisé en ce que** la barre (8) s'étend entre les deux lames (7). 55
9. Procédé de nettoyage, utilisant le dispositif de la revendication 1, dans lequel :
- le tissu de nettoyage sans fin en forme de manchon (9) est agencé pour être vissé par une ouverture dans une extrémité de celui-ci, autour de la portion de support oblongue (6) et est retenu contre celle-ci par la sollicitation d'un moyen de retenue de telle sorte qu'en cours d'utilisation, ledit tissu de nettoyage sans fin en boucle est apte à tourner autour de l'axe longitudinal dudit moyen de support oblong. 5
10. Procédé selon la revendication 10, **caractérisé en ce que** le tissu de nettoyage en boucle (9) est retenu dans la position au moyen d'un élément de ressort sollicité (4) portant contre la portion de support oblongue (6), et **en ce que** la force de sollicitation est supprimée en tirant l'élément élastique (4) au loin de la portion de support oblongue (6) au moyen de la portion de tige (1) fixée à l'élément élastique. 10

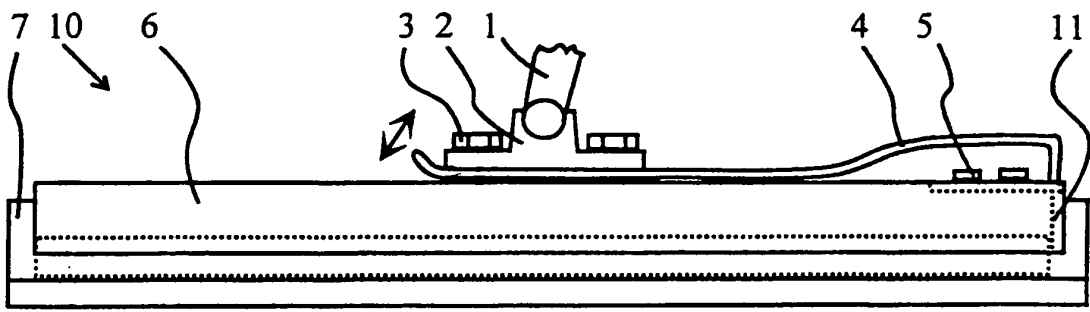

Fig. 1a

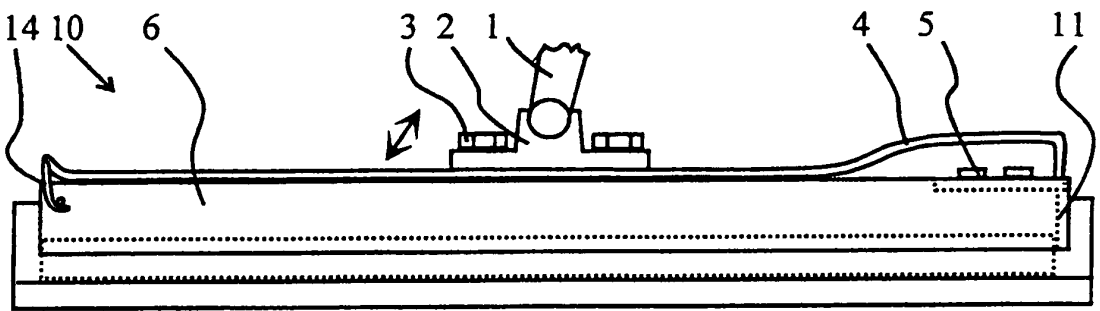

Fig. 1b

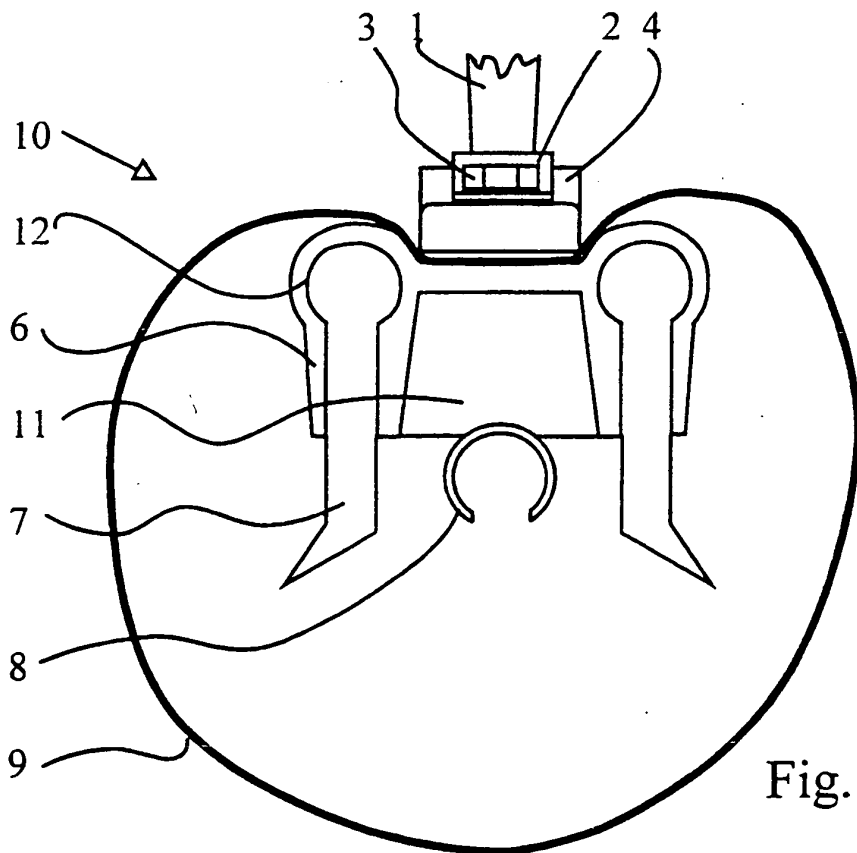

Fig. 2

