



(12) EUROPEAN PATENT APPLICATION

(43) Date of publication:
22.12.1999 Bulletin 1999/51

(51) Int Cl. 6: A63B 53/04

(21) Application number: 99304704.2

(22) Date of filing: 16.06.1999

(84) Designated Contracting States:
AT BE CH CY DE DK ES FI FR GB GR IE IT LI LU
MC NL PT SE
Designated Extension States:
AL LT LV MK RO SI

(72) Inventor: Buchanan, Douglas Boyd
Ludlow Shropshire SY8 1PH (GB)

(74) Representative: Skone James, Robert Edmund
GILL JENNINGS & EVERY
Broadgate House
7 Eldon Street
London EC2M 7LH (GB)

(30) Priority: 17.06.1998 GB 9812942

(71) Applicant: The Buchanan Putter Co., Ltd.
Ludlow, Shropshire, SY8 1EN (GB)

(54) Golf putter

(57) A golf putter (10) is provided. The golf putter (10) comprises a head (11) including a cavity (16). An insert member (17) is supported within the cavity (16) by means of Neoprene resilient O-rings (22,23) and a

shaft (14) or a hosel member (13) is connected to the insert (17). Because the insert member (17) is insulated from the head by the resilient O-rings less impact energy is dissipated within the head. The insert member (17) is arranged to be at the sweet spot of the head (11)

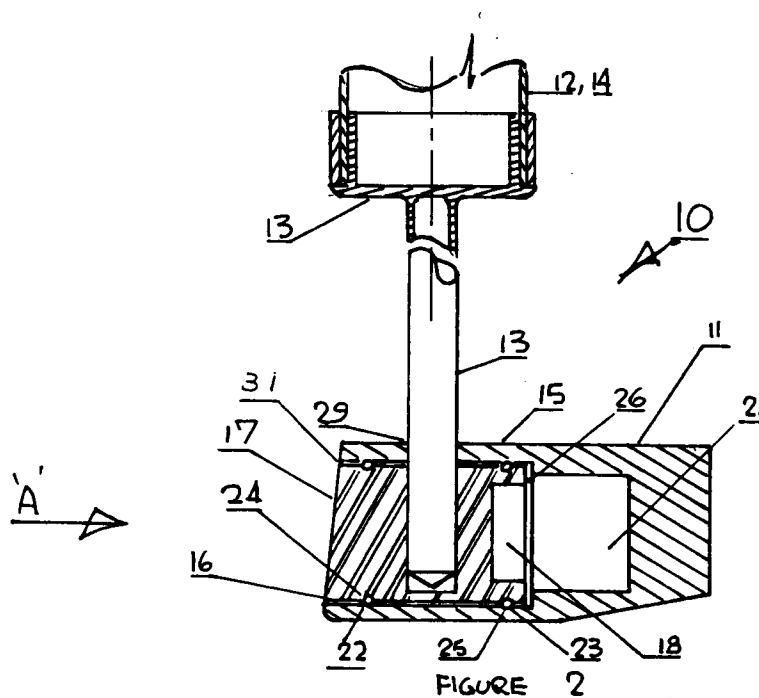

Description

[0001] This invention relates to a golf club. More particularly the invention is concerned with the provision of a novel connection between the head of a golf club and the shaft. In prior art golf clubs as shown in figure 1 a golf club 1 comprises a head 2 connected to a shaft 3. the head 2 has a striking face 4 with a so called sweet-spot 5 which is usually arranged to occur at the geometrical centre of area of the striking face 4 as indicated by the crossed lines. Ideally impact with a golf ball is sought to take place at the sweet-spot 5. A problem with this prior art arrangement is that the shaft 3 is displaced somewhat from the impact area and is fixed directly to the head 2. As a consequence of this some of the energy of impact is dissipated within the head thus lessening the amount of impact energy which can be transmitted up the shaft to the player's hands so that in one sense the amount of energy available to define "feel" is reduced.

[0002] According to the present invention there is provided a golf club having a head including a striking face with a sweet-spot, the head comprising an outer shell member defining a cavity, an insert located within the cavity spaced from the outer shell member and a shaft connection fixed to the insert through the outer shell.

[0003] The present invention will now be described by way of example only and with reference to the accompanying drawings wherein:

Figure 1 is a prior art golf club and connection.

Figure 2 is a part sectional elevation of a golf putter in accordance with the present invention.

Figure 3 is a part elevational view looking on arrow "A" of figure 2

Figure 4 is a perspective view of an insert used in the practice of the invention.

Figure 5 is a perspective view of a putter head and shaft connection in accordance with the present invention.

[0004] In figure 2 there is shown a golf putter 10 in accordance with the present invention. Golf putter 10 comprises a generally T-shaped head 11 connected to a shaft 12 by means of a hosel member 13. Hosel member 13 may be hollow. A shaft connection may comprise the hosel member 13 or the hosel member 13 may be dispensed with and the shaft connection may comprise a shaft 14 connected directly to the head 11. The head 11 comprises an outer shell member 15 which defines a cavity 16 within the head 11. An important part of the present invention is the use of a cylindrical inner insert member 17 located within cavity 16 of head 11. Insert member 17 is made of bronze material and defines a

rear cavity 18. The bronze material is selected to be a soft ductile material to facilitate the transmission of shock. A sweet spot 19 of the head 11 is arranged to be at the centre of the circular face area of insert 17 as indicated by the crossed lines as best seen in figure 4. An aperture 20 is formed in insert 17 by drilling and reaming to receive and ensure a proper fit with either hosel 13 or shaft 14. As seen in figure 2 hosel member 13 stops short of the end of the aperture 20 so that it does not contact outer shell member 15. It is believed this arrangement enhances the transmission of impact energy to the putter shaft as feel. Cavity 18 in combination with the remaining part of cavity 16 defines a void 21 in head 11. Void 21 is believed to increase the resonance factor of head 11. Insert 17 is supported and fixed within cavity 16 by means of Neoprene resilient O-rings 22, 23 fitted to semi-circular grooves 24, 25 formed around the circular periphery of insert 17. A small clearance exists between insert 17 and a shoulder 26 formed within outer shell member 15. Also as best seen in figure 2 the O-rings 22,23 space the insert 17 from outer shell member 15 so that a small clearance 31 is formed which in a sense insulates insert 17 from outer shell member 15. Stabilising or inertia weights 27 are let into the sides 28 of the head 11 to minimise the effect of off-centre hits. A slot 29, see figure 5, assists in aiming the striking face 30 of the putter head 11. Outer shell member 15 and hosel member 13 are made of aircraft quality high strength aluminium and when shaft 12,14 comprises a substantially large diameter shaft the shaft will be made of carbon fibre material. In addition to resiliently fixing insert 17 within cavity 16 the O-rings act as seals to prevent dirt and moisture from entering void 21 through clearance 31. Shaft 14 or hosel member 13 enters the aperture 20 in insert 17 through a hole 29 drilled in outer shell member 15. As can be appreciated from figure 3 because insert 17 is insulated from outer shell member 15 by the resilient O-rings any impact on insert 17 is transferred more or less directly to shaft 14 or hosel 13 with less impact energy being dissipated within head 11. Consequently a golf club, for example a putter as shown in figure 2 may have an increased "feel factor" due to the increased energy being transmitted up the shaft 12, 14. It has been found in practice that the void 21 also enhances the feel factor. The present invention may be used with so called standard shafts. However, the invention can be most advantageously used in a putter with a substantially large diameter (between 25 and 45mm), thin walled, parallel shaft to enhance the "feel factor". The present invention may be used in golf clubs other than putters but in that case due care must be taken with the design because of the higher forces that may be involved.

Claims

1. A golf club having a head including a striking face

with a sweet spot, the head comprising an outer shell member defining a cavity, an inner insert member located within the cavity spaced from the outer shell member and a shaft connection fixed to the insert through the outer shell member.

5

2. A golf club according to claim 1, wherein the inner insert member is resiliently supported within the cavity.

10

3. A golf club according to claim 2, wherein the inner insert member is supported by resilient O-rings.

4. A golf club according to claim 3, wherein the O-rings seal the insert within the cavity of the outer shell member.

15

5. A golf club according to claim 3 or claim 4, wherein the resilient O-rings comprise the material Neoprene.

20

6. A golf club according to any of the preceding claims, wherein the shaft connection comprises a hosel member fitted to the insert.

25

7. A golf club according to claim 6, wherein the hosel member fits within an aperture formed in the insert and stops short of the end of the aperture so that it does not contact the outer shell member.

30

8. A golf club according to claim 6 or claim 7, wherein the hosel member is hollow.

9. A golf club according to any of claims 6 to 8, wherein the shaft connection comprises a shaft fitted to the hosel.

35

10. A golf club according to claim 9, wherein the shaft member comprises a shaft of substantially large diameter (between 25 and 45mm), thin walled, parallel shaft.

40

11. A golf club according to any of claims 5 to 10, wherein the outer shell member and the hosel is made of high strength aircraft quality aluminium.

45

12. A golf club according to any of the preceding claims, wherein the insert defines the sweet spot of the head.

50

13. A golf club according to any of the preceding claims, wherein the insert includes a rear cavity.

14. A golf club according to claim 13, wherein the cavity in the rear of the insert and part of the cavity in the outer shell member form a void in the head.

55

15. A golf club according to any of the preceding claims,

the club comprising a putter.

16. A golf club according to any of the preceding claims, wherein the insert is made of a soft ductile bronze material.

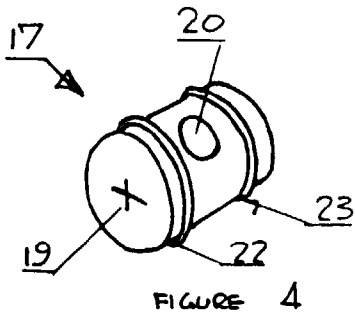
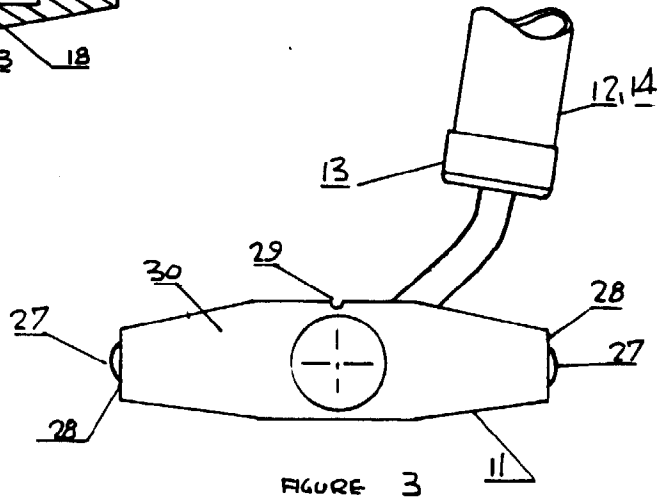
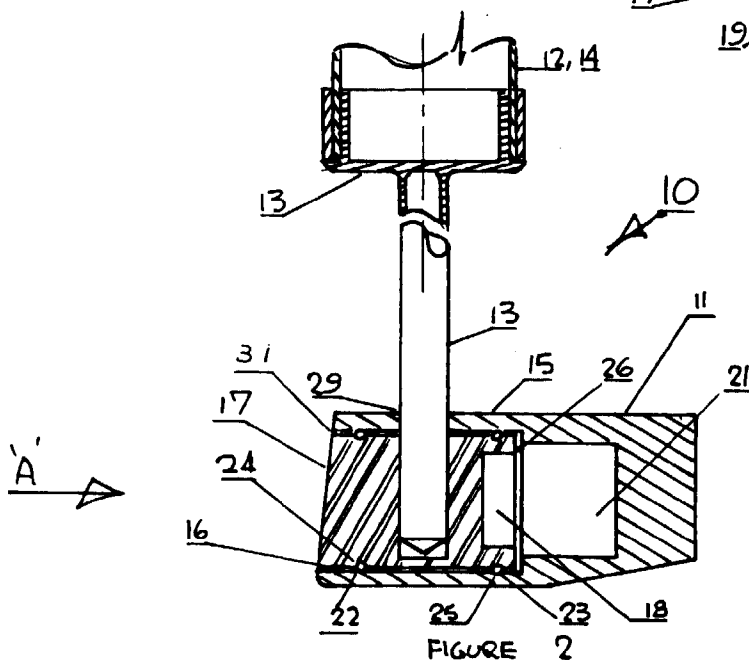
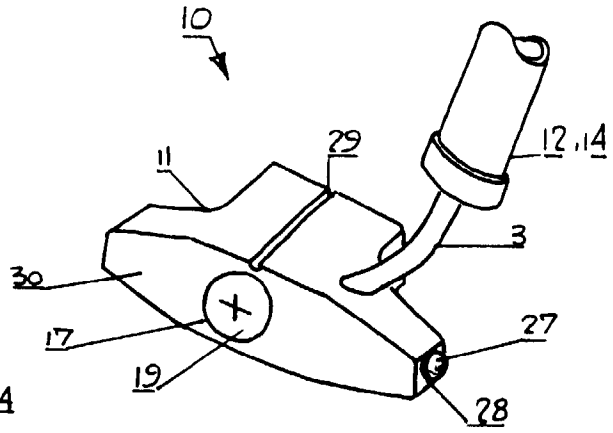
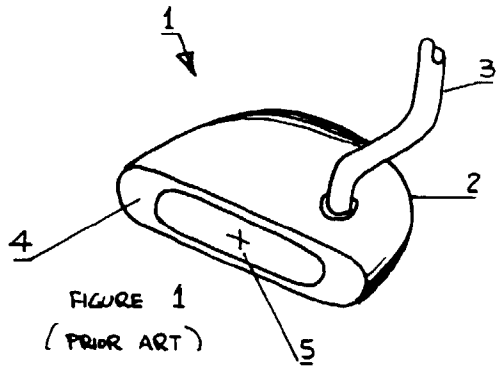



European Patent
Office

EUROPEAN SEARCH REPORT

Application Number
EP 99 30 4704

DOCUMENTS CONSIDERED TO BE RELEVANT			
Category	Citation of document with indication, where appropriate, of relevant passages	Relevant to claim	CLASSIFICATION OF THE APPLICATION (Int.Cl.6)
X	US 5 090 698 A (KLEINFELTER) 25 February 1992 (1992-02-25)	1, 15	A63B53/04
A	* the whole document *	3	
A	US 4 411 430 A (DIAN) 25 October 1983 (1983-10-25)	1-3, 12-15	
A	FR 2 672 226 A (DESBIOLLES) 7 August 1992 (1992-08-07)	1, 2, 15	
A	US 3 873 094 A (SEBO ET AL.) 25 March 1975 (1975-03-25)	1, 6, 12, 15, 16	
A	US 3 206 206 A (SANTOSUOSSO) 14 September 1965 (1965-09-14)	1	
A	US 3 387 844 A (SHIPPEE) 11 June 1968 (1968-06-11)	1	
A	US 5 632 694 A (LEE) 27 May 1997 (1997-05-27)		
A	US 4 324 404 A (DIAN) 13 April 1982 (1982-04-13)		
The present search report has been drawn up for all claims			
			A63B
Place of search	Date of completion of the search	Examiner	
THE HAGUE	21 September 1999	Williams, M	
CATEGORY OF CITED DOCUMENTS			
X : particularly relevant if taken alone Y : particularly relevant if combined with another document of the same category A : technological background O : non-written disclosure P : intermediate document T : theory or principle underlying the invention E : earlier patent document, but published on, or after the filing date D : document cited in the application L : document cited for other reasons & : member of the same patent family, corresponding document			

EPO FORM 1503 03 82 (P/04001)

**ANNEX TO THE EUROPEAN SEARCH REPORT
ON EUROPEAN PATENT APPLICATION NO.**

EP 99 30 4704

This annex lists the patent family members relating to the patent documents cited in the above-mentioned European search report. The members are as contained in the European Patent Office EDP file on
The European Patent Office is in no way liable for these particulars which are merely given for the purpose of information.

21-09-1999

Patent document cited in search report	Publication date	Patent family member(s)	Publication date
US 5090698 A	25-02-1992	NONE	
US 4411430 A	25-10-1983	US 4324404 A	13-04-1982
FR 2672226 A	07-08-1992	NONE	
US 3873094 A	25-03-1975	NONE	
US 3206206 A	14-09-1965	NONE	
US 3387844 A	11-06-1968	NONE	
US 5632694 A	27-05-1997	NONE	
US 4324404 A	13-04-1982	US 4411430 A	25-10-1983