



Europäisches Patentamt
European Patent Office
Office européen des brevets



(11) **EP 0 967 148 B1**

(12) **EUROPEAN PATENT SPECIFICATION**

(45) Date of publication and mention
of the grant of the patent:
29.01.2003 Bulletin 2003/05

(51) Int Cl.7: **B65B 9/02**, B65B 43/06

(21) Application number: **98118861.8**

(22) Date of filing: **06.10.1998**

(54) **Machine to automatically make up wrappers for brushes**

Maschine zum automatischen Formen von Umhüllungen für Pinsel

Machine pour la formation automatique d' enveloppes pour pinceaux

(84) Designated Contracting States:
AT BE CH DE ES FR GB GR IE IT LI LU NL PT SE
Designated Extension States:
SI

(72) Inventor: **Polese, Giovanni Pietro**
33070 Sarone di Caneva (PN) (IT)

(30) Priority: **23.06.1998 IT UD980104**

(74) Representative: **Petraz, Gilberto Luigi et al**
GLP S.r.l.
Piazzale Cavedalis 6/2
33100 Udine (IT)

(43) Date of publication of application:
29.12.1999 Bulletin 1999/52

(56) References cited:
GB-A- 2 232 950 **US-A- 2 547 835**
US-A- 4 152 880

(73) Proprietor: **Polese Giovanni Automation Srl**
33070 Stevena' di Caneva (PN) (IT)

EP 0 967 148 B1

Note: Within nine months from the publication of the mention of the grant of the European patent, any person may give notice to the European Patent Office of opposition to the European patent granted. Notice of opposition shall be filed in a written reasoned statement. It shall not be deemed to have been filed until the opposition fee has been paid. (Art. 99(1) European Patent Convention).

Description

FIELD OF THE INVENTION

[0001] This invention concerns a machine to automatically make up wrappers for brushes as set forth in the main claim.

[0002] The machine according to the invention is employed to wrap individual brushes endowing them with a protective wrapper suitable to wrap the end portion of the handle and the bunch of natural bristles, or artificial fibres, associated with the end portion.

[0003] In the following description, the term brush should be taken to mean an object equipped with a handle including, at the terminal end, bristles to be protected with a wrapper.

BACKGROUND OF THE INVENTION

[0004] In the state of the art, brushes are put on the market wrapped individually with a protective wrapper suitable to wrap the end portion of the handle and the bunch of bristles associated therewith.

[0005] At present, in order to accelerate the times required to apply the protective wrappers and therefore to reduce labour costs, various types of automatic making up machines have been proposed, but these have proved to be complex and costly, and not very efficient in operation.

[0006] Moreover, in many cases, the protective wrapper produced by these automatic making up machines such as are known to the state of the art has not proved to be suitable from the technical point of view, or has not satisfied the tastes of the market.

[0007] For example, the state of the art includes machines employing little bags made of plastic material, such as PVC, which are put onto the bunch of bristles and adapted to the shape of the brush by means of heat-sealing on part of the perimeter of the bag.

[0008] The adherence of the bags on the bristles of the brush is so unsatisfactory that, often, the brushes accidentally slip out of the respective bag.

[0009] As an alternative to PVC bags, it has also been proposed to use bags made of heat-shrinkable material; on the one hand, these solve the problem of the brushes accidentally slipping out of the bag, but on the other hand have the disadvantage that the heat-shrunk plastic film exerts on the bristles of the brush a force which is often such as to cause permanent deformations thereof, and therefore make the brush unusable.

[0010] Moreover, machines such as are known to the state of the art are not completely automatic and require some steps of the cycle to make up the wrappers to be carried out manually, which entails an increase in labour costs and low productivity.

[0011] To solve these problems, for some time now persons of skill have been studying to achieve making up machines suitable to perform automatically all the

steps of the cycle to make up protective wrappers.

[0012] However, these machines have not proved to be very reliable and versatile and above all, suitable to wrap different types of brushes or to achieve different types of wrapper.

[0013] The state of the art includes an automatic envelope machine wherein a continuous film fed from a roll is made to advance towards a station to insert brushes.

[0014] Before reaching this station, the film is folded substantially in half in correspondence with a median longitudinal axis, then sealed in correspondence with two lateral lines parallel and separated so as to define a shape like a bag closed on three sides and with an open front side, and then holed by means of a dinking machine in correspondence with the folding line, in a central position with respect to the two lateral lines of sealing.

[0015] The continuous film is fed to the station where the brushes are inserted with the front open side of the wrapper facing towards the brush which is to be introduced.

[0016] The brush is sent by means of an expulsion mechanism which acts orthogonally to the direction of advance of the film, on the side of the handle which is introduced through the open side of the wrapper and made to emerge through the hole made in the opposite closed side.

[0017] Then, the open side of the wrapper is sealed, the lateral sealing lines are cut and the brush, with the wrapper surrounding the bunch of bristles, is discharged from the line.

[0018] This machine has a plurality of disadvantages, including: it requires an auxiliary assembly to fold the film in half and an auxiliary assembly to achieve the hole through which the handle of the brush emerges.

[0019] Moreover, this machine allows to make only one type of wrapper, and therefore it does not allow to apply auxiliary reinforcing films, or dinking operations, or holes to hang the brush by, or opening limbs to remove the brush, which greatly limits the versatility and the possibilities of using this machine.

[0020] GB-A-2.232.950, which represents the most pertinent prior art in accordance with the preamble of claim 1, discloses a machine for packaging paint brushes in which the holders already sealed along their lateral sides are supplied in strip to a loading station where they are individually opened to receive the brush. This document does not disclose a machine suitable to feed stepwise and separately two strips towards a plane comprising at least a station where these strips are sealed each other at least along their lateral sides to obtain a wrapper partially closed and suitable to receive a brush.

[0021] The present Applicant has designed and embodied this invention to overcome these shortcomings which businessmen working in this field have long complained of, and to achieve other advantages as will be

shown hereafter.

SUMMARY OF THE INVENTION

[0022] The invention is set forth and characterised in the main claim, while the dependent claims describe variants of the idea of the main embodiment.

[0023] The purpose of the invention is to provide a machine to make up wrappers for brushes which is completely automatic, which has high productivity and which can be easily and rapidly equipped to allow a wide range of brushes, different in shape and/or in size, to be wrapped.

[0024] The machine according to the invention is suitable to provide at outlet brushes wrapped individually with substantially quadrangular wrappers which surround the end portion of the handle and the bunch of bristles associated therewith.

[0025] These wrappers are produced and applied automatically and individually on every individual brush starting from two strips of plastic film fed simultaneously above and respectively below the plane on which the brushes are fed or inserted.

[0026] The machine to wrap brushes according to the invention can be achieved in two embodiments.

[0027] In a first embodiment, the wrappers are formed starting from two strips of film, one above and one below, fed forwards parallel to each other.

[0028] The strips are automatically sealed and cut, advantageously in a single operation, around the bunch of bristles of the relative brush after the bunch of bristles has been inserted in an intermediate position between the two strips.

[0029] In the second embodiment, the wrappers are again formed starting from two strips of film fed forwards in parallel, but these are sealed at the sides before the bunch of bristles of the relative brush is inserted therein.

[0030] In this second embodiment therefore, the wrapper arrives at the station which feeds the brushes already partly closed, since only the front side where the brush is introduced is open.

[0031] When the brush has been inserted, a cutting assembly is activated which separates the formed wrapper, with the relative brush, from the continuous film pre-arranged to form the subsequent wrappers.

[0032] The machine according to the invention has a plurality of stations located in sequence which allow to produce different types of finished wrappers and particularly, but not only, wrappers stably sealed on three sides which, in order to be opened, require the plastic films to be broken, or wrappers having a re-sealable limb at the end, which allows to inspect the bristles of the brush or to remove the brush itself without breaking the plastic films.

[0033] The wrappers produced, moreover, can be reinforced in correspondence with a front side with at least a supplementary strip of plastic film or other desired material.

[0034] On the reinforced portion of the wrapper, moreover, it is possible to make through holes or eyelets which allow to hang the brushes on the display stands or similar used in the sales outlets.

[0035] The times required to equip the machine according to the invention with every change in production are very short, as it is only necessary to selectively activate particular stations according to the type of wrapper to be produced.

[0036] The machine according to the invention comprises at least a station to feed the brushes which can cooperate, in a variant of the invention, with a step advance assembly equipped with a plurality of gripper means, suitably separated from each other, which take the brushes to cooperate, one at a time, at least with a station to make up the wrappers and a station to discharge the wrapped brushes.

[0037] The step advance of the brushes is correlated to the advance of the strips of film.

[0038] According to a variant, between the making up station and the discharge station there are one or more supplementary stations which can be selectively activated.

[0039] These supplementary stations may include a station to complete the wrapper, for example used to apply to the wrapper at least a defined segment of supplementary strip, or other material, with a reinforcing function, a control station suitable to verify that the wrapper is correctly positioned and, possibly, to adapt the position, a dinking station employed to achieve through holes or eyelets which allow the brushes to hang on the display stands, a station to apply self-adhesive labels to seal the limb, if any, of the wrapper, or other stations.

[0040] In the preferential embodiment of the invention, the stations which define the machine are associated with common support means, for example a rail, which make the machine modular, thus allowing to add/remove one or more of the supplementary stations at any moment and in an extremely easy and rapid manner, so as to make the machine extremely versatile.

[0041] It is self-evident that the stations may always be included in line and can be selectively activated/deactivated according to the type of wrapper to be produced.

[0042] In the embodiment which includes the brush advance assembly, each gripper means of the advance assembly supports a single brush on the side of the handle, in such a way that the brush is cantilevered; thus the brushes are arranged orthogonally to the direction of advance with the bunch of bristles, free on all sides, suitable to cooperate with the individual stations which make up the machine.

[0043] The making up station is equipped with a feed assembly to feed two strips of plastic film, respectively upper film and lower film, which are fed respectively above and below the plane of positioning of the brushes.

[0044] The feed assembly is equipped with drawing means suitable to make the upper and lower films ad-

vance simultaneously for defined distances correlated to the transverse size of the brush to be wrapped.

[0045] The making up station comprises at least a sealing assembly consisting of two superimposed, movable elements, each supporting a respective plate element equipped with a heated element suitable to heat-seal the upper and lower films together, and at the same time to cut them in correspondence with the heat-sealed edges, as will be described in more detail hereafter.

[0046] The closure of the heated elements on the film causes the transverse cutting of the strip and the heat-sealing, two by two, of the superimposed edges of the film, on the right and on the left of the transverse cut.

[0047] As the heated elements approach each other, moreover, this causes a slight traction of the strips of film, which are held on the feed side; this allows to produce wrappers which adapt themselves perfectly to the shape of the ferrule and the bunch of bristles without compromising the quality thereof.

[0048] The wrappers produced are defined by two superimposed films which are heat-sealed by means of a first heat-seal located upstream of the brush and a second heat-seal located downstream of the same brush.

[0049] Each of the two facing heated elements has a shaping substantially mating with the lateral profile of the portion of the brush which is to be wrapped, suitable to perform simultaneously the second heat-seal of one wrapper and the first heat-seal of the subsequent wrapper.

[0050] The shape of the two heated elements, moreover, is such as to allow not only the transverse cutting and the simultaneous heat-sealing of the end to be cut, but also the elimination of the portions of excess film.

[0051] In one version of the invention, the heated elements are defined by several segments defining a particular geometric pattern.

[0052] In the preferential embodiment, these segments are specular with respect to the longitudinal axis of the heating element.

[0053] In one version of the invention, there is a first rectilinear segment suitable to cut and heat-seal the two superimposed films in correspondence with the lateral edges of the ferrule and the bunch of bristles and two other segments, sloping on opposite sides of the first segment, suitable to cut and heat-seal the two superimposed films in correspondence with the zone where the handle is attached to the ferrule and the bunch of bristles.

[0054] The heat-sealing performed by the two other segments gives the wrapper a shaping such as to prevent the brush from accidentally slipping out of the wrapper.

[0055] The machine according to the invention provides that the movable elements are interchangeable with other elements which have heated elements different in size and/or shape, which allows to wrap a wide range of types of brushes.

[0056] In another embodiment, there is a shaped

sealing element arranged upstream of the station to insert the brushes, and a cutting element arranged in correspondence with the station to insert the brushes, or immediately downstream thereof.

5 **[0057]** The sealing element is suitable to act on the two strips of film fed step by step towards the station to insert the brushes, so as to define two lateral heat-sealing lines, separated in a manner correlated to the width of the bunch of bristles of the brush.

10 **[0058]** The shaping with segments of the sealing element is such as to define, not only the said lateral lines, but also the partial closure of the rear side of the wrapper which is formed, in such a way as to keep only one aperture for the handle of the brush to pass through.

15 **[0059]** When this partly closed wrapper arrives at the station to insert the brushes, the relative brush is inserted on the side of the handle which goes in through the open front side of the wrapper and emerges from the aperture on the rear side.

20 **[0060]** According to a variant, there is an element suitable to widen the front side of the wrapper so as to facilitate the insertion of the handle of the brush.

25 **[0061]** This embodiment is particularly suitable for thick brushes, for which the heat-sealing performed after the brush has been inserted between the strips of film can sometimes cause problems.

BRIEF DESCRIPTION OF THE DRAWINGS

30 **[0062]** These and other characteristics of the invention will become clear from the following description of a preferential form of embodiment, given as a non-restrictive example, with the aid of the attached drawings wherein:

- 35 Fig. 1 is a view from above in diagram form of the machine according to the invention in a first embodiment;
- Fig. 2 is a side view of Fig. 1;
- 40 Fig. 3 is a side view of the making up station of the machine as shown in Fig. 1;
- Fig. 4 is a side view of Fig. 3;
- Figs. 5a-5f show in diagram form the making up steps performed by the making up station shown in Fig. 3;
- 45 Fig. 6 is a three-dimensional view of a detail of Fig. 3;
- Fig. 7 shows the section from A to A of Fig. 6;
- Figs. 8a-8b show a view from above of some steps in the making up of a wrapper on a brush;
- 50 Fig. 9 shows an enlarged detail of Fig. 6;
- Fig. 10 shows a variant of Fig. 9;
- Fig. 11 shows a brush wrapped with the machine according to the invention.
- 55 Figs. 12a-12f show in diagram form the making up steps of a brush in a variant of the invention;

Fig. 13 is a view from B of Fig. 12d.

DETAILED DESCRIPTION OF A PREFERRED EMBODIMENT

[0063] With reference to the attached Figures, a machine 10 according to the invention is suitable to automatically wrap brushes 18, each having a handle 22, a bunch of bristles 32 and a containing ferrule 33.

[0064] The machine 10 comprises a plurality of stations 11-17 arranged in series.

[0065] To be more exact, there is a feed station 11, a making up station 12, a control station 13, a completion station 14, a dinking station 15, a finishing station 16 and a discharge station 17.

[0066] The brushes 18 are taken, sequentially and individually, from one station to the other by means of a step advance assembly 19 on which a plurality of positioning and clamping elements 20 are arranged in an orderly fashion, separated from each other by a length equal to one step, or a multiple of one step, of the advance assembly 19.

[0067] In this case, the advance assembly 19 comprises flexible means 21, closed in a ring, for example a belt, a chain, a track or similar, on which the positioning and clamping elements 20 are arranged in an orderly fashion.

[0068] Each positioning and clamping element 20 is suitable to cooperate temporarily with the handle 22 of the brush 18 to clamp it during its movement from the feed station 11 to the discharge station 17.

[0069] The positioning and clamping elements 20 are, for example, of the gripper type and comprise elastic means which hold them usually in the clamping position.

[0070] The feed station 11 comprises a series of conveyor belts 23 cooperating with conveyor walls 24 suitable to deliver a single brush 18 at a time to the positioning and clamping elements 20.

[0071] Each positioning and clamping element 20, when it is arranged aligned with the conveyor walls 24, temporarily assumes the release position so as to allow the handle 22 to be introduced between its two clamping pincers.

[0072] The making up station 12 comprises a feed assembly 25 to feed two strips, upper 27 and lower 28, of plastic film such as PVC, polythene, ethylene copolymers or otherwise, located respectively above and below a horizontal sliding plane 29 on which the brushes 18 move.

[0073] The strips of film 27 and 28 arrive from respective rolls and slide over respective slideways 26 converging at the front towards the sliding plane 29.

[0074] The slideways 26, as can be seen in Fig. 3, are defined by jaws 30; the jaws 30 are driven by actuators 31, for example of the pneumatic type, and are equipped with alternative to-and-fro movement along the corresponding slideway 26.

[0075] The alternative movement is coordinated and

synchronised with the step of advance of the advance assembly 19.

[0076] During the advance movement, the jaws 30 are suitable to assume a position to grip the respective films 27 and 28, so as to draw them individually by a length defined and adjustable according to the size of the brush, while, during the reverse movement, they are suitable to assume a position of non-interference, where they release the respective films 27, 28.

[0077] The films 27, 28 are superimposed one above the other in correspondence with a heat-sealing assembly 34 so that between them it is possible to insert the portion of the brush 18 which is to be wrapped, that is to say, the bunch of bristles 32, the ferrule 33 and the wider part of the handle 22.

[0078] The heat-sealing assembly 34 comprises two plates, upper 35a and lower 35b, specular to each other and movable vertically in the opposite direction from an inactive position, wherein they are distanced from the strips of film 27 and 28, to a working position wherein they abut together and therefore are in contact with the two strips of film 27 and 28.

[0079] The plates 35a and 35b are assembled on respective supports 36a and 36b in such a manner as to be removable.

[0080] In this way each pair of plates 35a and 35b is interchangeable with other pairs of plates which may be different in shape and/or size.

[0081] The supports 36a and 36b are associated with respective actuators 37a and 37b, for example of the pneumatic type, supported by a pair of parallel brackets 38, in this case, C-shaped.

[0082] Each plate 35a and 35b has, on its working face, a corresponding heated blade 39, substantially shaped to mate with the lateral profile of the brush 18 to be wrapped.

[0083] The heated blade 39 consists of, or is associated with, an electric resistor fed with set values of electric tension.

[0084] The heated blade 39, as shown in Fig. 7, has a sharp profile defined by an upper peak 39a connected with two lateral segments 39b.

[0085] When the upper peaks 39a of the two opposite heated blades 39 come to abut, they cut transversely the two superimposed strips of film 27 and 28, and the lateral segments 39b heat-seal the edges of the strips 27 and 28 both on the right and on the left of the cutting line.

[0086] As shown in Fig. 8c, this allows to heat-seal the second side of the wrapper 40 downstream of the heat-sealing assembly 34 and the first side of the wrapper 40 upstream of the same assembly 34 at the same time.

[0087] In the embodiment shown in Figs. 6 and 9, each heated blade 39 is defined by several segments, in this case three: the first segment 139 is rectilinear and is suitable to cut and heat-seal the two films 27 and 28 in correspondence with the lateral edges of the ferrule

33 and the bunch of bristles 32; the second segment 239 and the third segment 339, sloping on opposite sides of the first segment 139, are suitable to cut and heat-seal the two films 27 and 28 in correspondence with the area where the handle 22 is attached to the ferrule 33 and the bunch of bristles 32.

[0088] The segments 239 and 339 give each wrapper 40 produced (Fig. 11) a shape suitable to prevent the brush from accidentally slipping out of the wrapper 40, if the brush 18 should be pulled on the side of the handle 22.

[0089] The segments 239 and 339, moreover, allow to eliminate automatically the triangular shaped scraps 41 (Fig. 8c) of the films 27 and 28.

[0090] In one version of the invention, the elimination of the scraps 41 is facilitated by blowing means which are not shown here, which encourage the removal of the discards 41 from the heat-sealing zone.

[0091] The size of the three segments 139, 239 and 339 and the angle of the segments 239 and 339 with respect to the first segment 139 are a function of the type of brush 18 to be wrapped.

[0092] In the two versions shown in Figs. 9 and 10, the heated blades 39 define a substantial Y shape and a substantial T shape, which allow to wrap respective brushes with the handle 22 connected to the ferrule 33, like those shown in the attached figures, and brushes with a much wider bunch of bristles 32.

[0093] In this case, the upper strip of film 27 is narrower than the lower strip of film 28, so that a re-sealable limb 140 is formed on the end of the wrapper 40 as it emerges from the making up station 12.

[0094] It is self-evident that the strips of film 27 and 28 may also have the same width, to allow to make wrappers which are heat-sealed also in correspondence with the third side adjacent to the end portion of the bunch of bristles 32.

[0095] We shall now see, with the help of Figs. 5a-5f, a making up cycle carried out by the making up station 12 as described above.

[0096] When the machine 10 is first activated, the strips of film, upper 27 and lower 28, are superimposed but not heat-sealed together (Fig. 5a).

[0097] The strips of film 27 and 28 are therefore made to advance by a desired length and the plates 35a and 35b are activated so that a first heat-sealing 42 is performed in correspondence with the leading end of the strips of film 27 and 28 and, at the same time, the front scrap 43 of the strips of film 27 and 28 (Figs. 5b-5c) is discarded.

[0098] At this point the machine 10 is ready to carry out - and repeat in cycles - the steps shown in Figs. 5c-5f.

[0099] When the first heat-seal 42 has been performed (Fig. 8a), the advance assembly 19 feeds forward simultaneously the brushes 18, already loaded on the positioning and clamping elements 20, so that the feed assembly 25 feeds forwards the strips of film 27

and 28 by a section correlated to the advance of the brushes 18.

[0100] The end portion of the first brush 18, which is still to be wrapped, moves along the horizontal sliding plane 29, comes between the two heat-sealed films 27 and 28 and arranges itself downstream of the plates 35a and 35b of the heat-sealing assembly 34 (Fig. 5d).

[0101] At this point, the plates 35a and 35b abut (Fig. 5e), performing the second heat-seal 44 of the wrapper 40 and at the same time the first heat-seal 42 of the subsequent wrapper 40 (Fig. 8c).

[0102] Subsequently, the advance assembly 19 is activated by one more step so that the wrapped brush 18 passes to the next station, in this case the control station 13 and, at the same time, a new brush 18 arrives at the making up station 12.

[0103] The control station 13 verifies that the wrappers 40 have been correctly positioned on the brushes 18.

[0104] In one version of the invention, the control station 13 may comprise pincer means, which are not shown in the Figures, which can grip the free end of the wrapper 40, whether it have the re-sealable limb 140 or not, and pull it in the direction opposite the handle 22 so that the wrapper 40 is perfectly adapted to the shape of the brush 18.

[0105] The correct positioning of the wrapper 40 is an indispensable condition for the correct functioning of the subsequent stations 14, 15 and 16 which, as already said, can even be optional.

[0106] The subsequent dinking station 15 is employed to make, in correspondence with the third side of the wrapper, one or more holes or eyelets which allow to hang the brushes 18 on the display stands in the sales points.

[0107] The subsequent finishing station 16 is suitable to close the limb 140, if any, and constrain it to the body of the wrapper 40 by means of a self-adhesive label, a clip, or otherwise.

[0108] After passing through the last station 16 of the machine 10, the brush 18 continues to advance step by step until it reaches the discharge station 17, where the positioning and clamping elements 20 are automatically unclamped so as to allow the wrapped brush 18 to reach a conveyor belt 46 cooperating with collection means which are not shown in the Figures.

[0109] In the variant shown in Figs. 12a-12f and 13, the brushes 18 are grouped together in the making up station 12 and cooperate with an introduction element 47 suitable to move them in a direction orthogonal to the direction of advance 48 of the strips of film 27 and 28.

[0110] Only the upper strip 27 can be seen in the Figures, as the lower strip 28 is arranged below.

[0111] In this embodiment the sealing assembly 34 is arranged upstream of the position wherein the brushes 18 are introduced and acts on the strips 27 and 28, which are fed forwards step by step by the relative feed assembly (not shown here), in such a manner as to heat-

seal the two strips 27 and 28 together, in correspondence with parallel and separate sealing lines.

[0112] To be more exact, the making up cycle provides that the strips of film 27 and 28 are fed forwards in the direction of advance 48 towards the station 12 where the brushes 18 to be wrapped are (Fig. 12a).

[0113] After the sealing assembly 34 has stopped the advance of the strips 27 and 28, it performs the heat-sealing only, while the strips 27 and 28 are flat, it does not also cut, thus defining the first heat-sealing line 42 (Fig. 12b).

[0114] The strips 27 and 28 are then fed forwards by one step corresponding to the width of a first finished wrapper 40a, then they are stopped and then heat-sealed together by the heat-sealing assembly 34 so as to define the second heat-sealing line 44 (Fig. 12c).

[0115] The shape of the heated blades 39 of the sealing assembly 34 as shown in Fig. 9 causes a hole 50 to be defined directly on the rear side of the first wrapper 40a, closed at the sides and still associated with the relative strips 27 and 28, without the need for any further operations or specific equipment.

[0116] Once the wrapper 40a is positioned in front of the first brush 18a located in the insertion position, the introduction element 47 is made to act; this pushes the brush 18a, arranged with the handle 22 facing towards the plane of advance of the strips 27, 28, inside the wrapper 40a through its front side.

[0117] In this step, a suction element 51 is activated which acts from above on the strip 27 and opens the front side of the wrapper 40a, facilitating the introduction of the brush 18a inside.

[0118] The handle 22 emerges from the rear side of the wrapper 40a through the hole 50, and the brush 18a is pushed until the bunch of bristles 32 is completely positioned inside the wrapper 40a (Fig. 12d).

[0119] At this point, the introduction element 47 is retracted, the strips 27 and 28 are fed forwards by one step, taking the second wrapper 40b into the position wherein the brushes 18 are inserted, and taking the first heat-sealing line 42 in correspondence with a cutting element 52.

[0120] The cutting element 52 is activated to cut the first side of the wrapper 40a (Fig. 12e), and this operation determines the formation of a front segment of scrap 43 which is discharged.

[0121] At the same time, a second brush 18b is taken into correspondence with the introduction element 47 and then pushed inside the relative wrapper 40b, after the suction element 51 has been activated to open the front side.

[0122] As the strips 27 and 28 advance a further step forward, this causes the second sealing line 44 to be positioned in correspondence with the cutting element 52; the cutting action of the cutting element 52 definitively separates the first wrapper 40a from the strips 27 and 28, with the relative brush 18a inside it, and, as a result, the first side of the second wrapper 40b (Fig. 12f)

is also cut.

[0123] The first wrapped brush 18a is sent to the completion station 14 where the front side is closed and possibly reinforced, and the making up cycle is then repeated for the subsequent brushes 18.

[0124] Fig. 13 is a side view of the making up station 12 and shows the action of the suction element 51 to open the front side of the wrapper 40 during the step when the brush 18 is inserted.

[0125] It is obvious that modifications and additions may be made to this invention, yet will remain within the scope thereof.

[0126] For example, the advance assembly 19, instead of advancing in a linear direction, may be of the type which has a circular advance, according to the requirements of the layout of the making up plant.

Claims

1. Machine to automatically make up wrappers for brushes (18), the wrappers having a substantially quadrangular shape defined by two superimposed strips of film, respectively upper (27) and lower (28), sealed together at least in correspondence with a first and second side parallel and facing each other, the wrapper (40) also including a front side wherein the brushes (18) are inserted and a rear side, the machine being **characterised in that** it includes in sequence at least a station (11) to stepwise feed the brushes (18) to be wrapped and insert them between the strips and a station (12) to make up the wrappers, the making up station (12) comprising a sealing assembly (34) consisting of two heated elements (39) opposite each other with respect to the plane of advance of the strips of film (27, 28) and movable one towards the other between a first inactive position, not in contact with the strips of film (27,28), and a second working position in contact with the strips of film (27,28), the heated elements (39) having a shape substantially mating with the lateral profile of the brush (18) to be wrapped, the sealing assembly (34) being suitable to heat-seal the first and second side of the wrapper (40), and **in that** a feed assembly (25) is suitable to feed the strips (27, 28) and is defined by two slideways (26) converging towards a plane (29) on which the brushes (18) advance, each of said slideways (26) being defined by jaw means (30) equipped with alternate to-and-fro movement coordinated and synchronised with the step of the advancing brushes (18), the jaw means (30) assuming, during the advance movement, a position wherein they grip and draw the respective film (27 or 28) and, during the reverse movement, a position wherein they release the respective film (27 or 28).

2. Machine as in Claim 1, **characterised in that** the

sealing assembly (34) is suitable to heat-seal and simultaneously cut the first and second side of the wrapper (40) after the brush (18) has been inserted inside.

3. Machine as in Claim 1, **characterised in that** the sealing assembly (34) is suitable only to heat-seal the first and second side of the wrapper (40) before the brush (18) has been inserted inside, there being included, downstream of the sealing element (34), a cutting element (52) suitable to cut the first and second side of the wrapper (40) after the brush (18) has been inserted.
4. Machine as in Claim 3, **characterised in that** the sealing assembly (34) is suitable to define, on the rear side of the wrapper (40), a hole (50) for the handle (22) of the brush (18) to pass through during the step when the brush (18) is inserted inside the wrapper (40).
5. Machine as in Claim 1, **characterised in that** the heated elements (39) are suitable to eliminate the scraps (41) of excess film (27,28).
6. Machine as in Claim 1, **characterised in that** each heated element (39) comprises a blade with a substantially rectilinear part (139) and two terminal elements (239, 339) specular to each other with respect to the longitudinal axis of the substantially rectilinear part (139).
7. Machine as in Claim 6, wherein each brush (18) comprises a handle (22), a bunch of bristles (32) and a containing ferrule (33), **characterised in that** the substantially rectilinear part (139) is transverse to the direction of advance of the brushes (18), and is suitable to heat-seal the films (27, 28) in correspondence with the lateral edge of the ferrule (33) and the bunch of bristles (32) of the brush (18) and that the terminal elements (239, 339), sloping on opposite sides of the first part (139), are suitable to heat-seal the films (27, 28) in correspondence with the section where the handle (22) is attached to, or connected with, the ferrule (33).
8. Machine as in Claim 6, **characterised in that** the heated element (39) is substantially Y-shaped.
9. Machine as in Claim 6, **characterised in that** the heated element (39) is substantially T-shaped.
10. Machine as in Claim 6, **characterised in that** the heated element (39) is solid with a respective plate (35a, 35b) assembled in the making up station (12) in a removable manner.
11. Machine as in Claim 10, **characterised in that** the

plates (35a, 35b) are interchangeable with other plates having heated elements (39) of different shape or size.

- 5 12. Machine as in any claim hereinbefore, **characterised in that** the superimposed films (27, 28) have different widths so as to achieve a re-sealable limb (140) on a third side of the wrappers (40).
- 10 13. Machine as in any claim hereinbefore, **characterised in that** downstream of the making up station (12) supplementary stations (13-16) can be selectively inserted and that an advance assembly (19) is suitable to move the brushes from one of the stations to another (13-16).
- 15 14. Machine as in Claim 13, **characterised in that** the supplementary stations comprise a station (13) to control the positioning of the wrappers (40) on the respective brushes (18), a station (14) to complete the wrappers (40), a dinking station (15) and a finishing station (16) to finish the wrappers (40).
- 20 15. Machine as in Claim 14, **characterised in that** the advance assembly (19) consists of flexible drawing means (21) closed in a ring, with which positioning and clamping elements (20) are made solid at defined distances one from the other, the positioning and clamping elements (20) being suitable to cooperate temporarily with the handle (22) of the brush (18).
- 25
- 30

Patentansprüche

- 35 1. Maschine zum automatischen Formen von Umhüllungen für Pinsel (18), wobei die Umhüllungen im wesentlichen eine viereckige Form aufweisen, definiert durch zwei überlagerte Streifen von Filmen, respektive eines oberen (27) und eines unteren (28), zusammengesiegelt wenigstens in Übereinstimmung mit einer ersten und zweiten parallelen Seite und gegeneinander gerichtet, wobei die Umhüllung (40) ebenfalls beinhaltet eine Frontseite, worin die Pinsel (18) eingefügt werden, und einer Rückseite, wobei die Maschine **dadurch gekennzeichnet ist, dass** sie der Reihe nach beinhaltet, wenigstens eine Station (11) für die schrittweise Zuführung der Pinsel (18), um umhüllt und anschließend eingefügt zu werden zwischen den Streifen und einer Station (12) für die Formgebung der Umhüllung, wobei die Station (12) für die Formgebung beinhaltet eine Vorrichtung (34) für die Siegelung, bestehend aus zwei beheizten Elementen (39), angeordnet gegenüber liegend voneinander in bezug auf die Ebene des Vorschubs der Streifen von Filmen (27, 28) und einer gegen den anderen hin beweglich zwischen einer ersten, inaktiven Position,
- 40
- 45
- 50
- 55

- in welcher sie nicht in Kontakt mit den Streifen der Filme (27, 28) sind, und einer zweiten, Arbeits-Position, in welcher sie in Kontakt mit den Streifen der Filme (27, 28) sind, wobei die beheizten Elemente (39) eine Form aufweisen, welche sich im Wesentlichen decken mit dem lateralen Profil der Pinsel (18), welche umhüllt werden sollen, wobei die Vorrichtung (34) für die Siegelung dazu geeignet ist, die erste und die zweite Seite der Umhüllung (40) Hitze zu siegeln und darin, dass eine Vorrichtung (25) für den Vorschub dazu geeignet ist, die Streifen (27, 28) vorzuschieben und definiert ist durch zwei Gleitwege (26), welche gegen eine Ebene (29) konvergieren, auf welcher die Pinsel (18) weitergeführt werden, wobei jeder dieser Gleitwege (26) definiert werden durch Klemm-Mittel (30), welche mit einer alternierenden Hin- und Zurückbewegung versehen ist, koordiniert und synchronisiert mit dem Schritt der vorwärts bewegten Pinsel (18), die Klemm-Mittel (30) übernehmend, während der Vorschubbewegung, eine Position, in welcher das Greifen und Ziehen des entsprechenden Filmes (27, 28) und während der rückwärts gerichteten Bewegung, eine Position, in welcher sie den entsprechenden Film (27, 28) zurück lassen.
2. Maschine nach Anspruch 1, **dadurch gekennzeichnet, dass** die Vorrichtung (34) zum Siegeln dazu geeignet ist, Hitze zu siegeln und simultan dazu die erste und die zweite Seite der Umhüllung (40) zu schneiden, nachdem der Pinsel (18) darin eingebracht wurde.
 3. Maschine nach Anspruch 1, **dadurch gekennzeichnet, dass** die Vorrichtung (34) zum Siegeln dazu geeignet ist, die erste und die zweite Seite der Umhüllung (40) lediglich Hitze zu siegeln, bevor der Pinsel (18) darin hinein zugeführt wurde, wobei ein Element (52) zum Schneiden vorhanden ist, welches stromabwärts des Elements (34) für die Siegelung angeordnet ist und dazu geeignet ist, die erste und die zweite Seite der Umhüllung (40) zu schneiden, nachdem der Pinsel (18) darin eingefügt wurde.
 4. Maschine nach Anspruch 3, **dadurch gekennzeichnet, dass** die Vorrichtung (34) für die Siegelung dazu geeignet ist, an der Rückseite der Umhüllung (40) eine Öffnung (50) für den Griff (22) des Pinsels (18) zu definieren, durch welche dieser während des Schrittes, wenn der Pinsel (18) in die Umhüllung (40) hinein zugeführt wird.
 5. Maschine wie in Anspruch 1, **dadurch gekennzeichnet, dass** die beheizten Elemente (39) dazu geeignet sind, die Stückchen (41) der überflüssigen Filme (27, 28) zu eliminieren.
 6. Maschine nach Anspruch 1, **dadurch gekennzeichnet, dass** jedes beheizte Element (39) eine Klinge beinhaltet mit einem im Wesentlichen geraden Teil (139) und zwei abschliessenden Elementen (239, 339) gespiegelt zueinander, in bezug zu der longitudinalen Achse zu dem im Wesentlichen geraden Teil (139).
 7. Maschine nach Anspruch 6, wobei jeder Pinsel (18) einschliesst einen Griff (22), ein Bündel von Borsten (32) und einen beinhalteten Ringbeschlag (33), **dadurch gekennzeichnet, dass** der im Wesentlichen geradlinige Teil (139) quer zur Richtung des Vorschubs der Pinsel (18) liegt, und dazu geeignet ist, die Filme (27, 28) in Übereinstimmung mit den lateralen Kanten des Ringbeschlages (33) und des Bündels von Borsten (32) des Pinsels (18) Hitze zu siegeln und dass die abschliessenden Elemente (239, 339), welche sich an gegenüberliegenden Seiten des ersten Teiles (139) zurück neigen, dazu geeignet sind, die Filme (27, 28) in Übereinstimmung mit der Sektion, in welcher der Griff (22) angefügt wird an oder verbunden wird mit dem Ringbeschlag (33) Hitze zu siegeln.
 8. Maschine nach Anspruch 6, **dadurch gekennzeichnet, dass** die beheizten Elemente (39) im Wesentlichen Y-förmig ausgebildet sind.
 9. Maschine nach Anspruch 6, **dadurch gekennzeichnet, dass** die beheizten Elemente (39) im Wesentlichen T-förmig ausgebildet sind.
 10. Maschine wie in Anspruch 6, **dadurch gekennzeichnet, dass** die beheizten Elemente (39) fest sind in Bezug auf eine Platte (35a, 35b), welche in der Station (12) für die Formgebung in einer verstellbaren Art und Weise angeordnet ist.
 11. Maschine nach Anspruch 10, **dadurch gekennzeichnet, dass** die Platten (35a, 35b) austauschbar mit anderen Platten sind, welche beheizte Elemente (39) mit unterschiedlicher Formgebung oder Grösse aufweisen.
 12. Maschine wie in einem der vorangehenden Ansprüche, **dadurch gekennzeichnet, dass** die überlagerten Filme (27, 28) unterschiedliche Breiten aufweisen, so dass eine wiederverschliessbare Lippe (140) an einer dritten Seite der Umhüllung (49) ausgebildet wird.
 13. Maschine wie in einem der vorangehenden Ansprüche, **dadurch gekennzeichnet, dass** stromabwärts der Station (12) für die Formgebung zusätzliche Stationen (13-16) selektiv eingefügt werden können und dass eine Vorrichtung (19) für den Vorschub dazu geeignet ist, die Pinsel von einer Stati-

on zu einer anderen (13-16) zu verbringen.

14. Machine wie in Anspruch 13, **dadurch gekennzeichnet, dass** die zusätzlichen Stationen eine Station (13) einschliessen, um die Positionierung der Umhüllung (40) des betreffenden Pinsels (18) zu überprüfen, eine Station (14) für die Vervollständigung der Umhüllung (40), eine Station (15) zum Stanzen und eine Station für den Abschluss (16), um die Umhüllung (40) abzuschliessen.
15. Maschine wie in Anspruch 14, **dadurch gekennzeichnet, dass** die Vorrichtung (19) für den Vorschub besteht aus flexiblen Zugmitteln (21), geschlossen in einem Ring, mit welchem die Positionier- und Klemmelemente (20) eines vom anderen in einem definierten Abstand festgemacht werden, wobei die Positionier- und Klemmelemente (20) dazu geeignet sind, seitlich mit den Griffen (22) der Pinsel (18) zusammen zu arbeiten.

Revendications

1. Machine pour confectionner automatiquement des enveloppes à pinceaux (18), les enveloppes ayant une forme fondamentalement quadrangulaire définie par deux bandes de pellicule superposés, respectivement supérieur (27) et inférieur (28), soudés entre eux au moins en correspondance d'un premier et d'un deuxième côté parallèles et tournés l'un vers l'autre, l'enveloppe (40) comprenant aussi un côté antérieur dans lequel les pinceaux sont insérés et un côté postérieur, la machine étant **caractérisée en ce qu'elle** comprend en séquence au moins une station (11) pour alimenter pas à pas les pinceaux (18) à envelopper et les insérer entre les rubans et une station (12) de confection des enveloppes, la station (12) de confection comprenant un groupe de soudure (34) composé de deux éléments réchauffés (39) opposés entre eux par rapport au plan d'avance des bandes de pellicule (27, 28) et mobiles l'un vers l'autre entre une première position inactive, non en contact avec les bandes de pellicule (27, 28) et une deuxième position de travail en contact avec les bandes de pellicule (27, 28), les éléments réchauffés (39) ayant une forme fondamentalement conjuguée au profil latéral du pinceau (18) à envelopper, le groupe de soudure (34) étant apte à thermosouder le premier et le deuxième côté de l'enveloppe (40), et **en ce que** un groupe d'alimentation (25) est apte à alimenter les bandes (27, 28) et est défini par deux goulottes (26) convergentes vers un plan (29) sur lequel les pinceaux (18) avancent, chacune des goulottes (26) susdites étant définie par des moyens à mâchoire (30) pourvus de mouvement alterné d'avance-recul coordonné et synchronisé avec les pas des pinceaux (18) qui

avancent, les moyens à mâchoire (30) prenant pendant le mouvement d'avance une position dans laquelle ils saisissent et traînent la pellicule (27 ou 28) respective et, pendant le mouvement de recul, une position dans laquelle ils relâchent la pellicule (27 ou 28) respective.

2. Machine selon la revendication 1, **caractérisée en ce que** le groupe de soudure (34) est apte à thermosouder et couper simultanément le premier et le deuxième côté de l'enveloppe (40) après que le pinceau (18) a été inséré à l'intérieur.
3. Machine selon la revendication 1, **caractérisée en ce que** le groupe de soudure (34) est apte seulement à thermosouder le premier et le deuxième côté de l'enveloppe (40) avant que le pinceau (18) ait été inséré à l'intérieur, un élément de découpage (52) apte à couper le premier et le deuxième côté de l'enveloppe (40) après que le pinceau (18) a été inséré étant compris en aval de l'élément de soudure (34).
4. Machine selon la revendication 3, **caractérisée en ce que** le groupe de soudure (34) est apte à définir sur le côté postérieur de l'enveloppe (40) un trou (40) pour faire passer la manche (22) du pinceau (18) pendant la phase dans laquelle le pinceau (18) est inséré à l'intérieur de l'enveloppe (40).
5. Machine selon la revendication 1, **caractérisée en ce que** les éléments réchauffés (39) sont aptes à éliminer les restes (41) de la pellicule (27, 28) excédentaire.
6. Machine selon la revendication 1, **caractérisée en ce que** chaque élément réchauffé (39) comprend une lame ayant une partie (139) fondamentalement rectiligne et deux éléments terminaux (239, 339) spéculaires entre eux par rapport à l'axe longitudinal de la partie (139) fondamentalement rectiligne.
7. Machine selon la revendication 6, dans laquelle chaque pinceau (18) comprend une manche (22), une gerbe de soies (32) et un embout conteneur (33), **caractérisée en ce que** la partie (139) fondamentalement rectiligne est transversale à la direction d'avance des pinceaux (18) et apte à thermosouder les pellicules (27, 28) en correspondance du rebord latéral de l'embout (33) et de la gerbe de soies (32) du pinceau (18), et **en ce que** les éléments terminaux (239, 339), inclinés de parties opposées par rapport à la première partie (139), sont aptes à thermosouder les pellicules (27, 28) en correspondance de la section dans laquelle la manche (22) est fixée ou reliée à l'embout (33).
8. Machine selon la revendication 6, **caractérisée en**

ce que l'élément réchauffé (39) est fondamentalement en forme de Y.

9. Machine selon la revendication 6, **caractérisée en ce que** l'élément réchauffé (39) est fondamentalement en forme de T. 5
10. Machine selon la revendication 6, **caractérisée en ce que** l'élément réchauffé (39) est solidaire d'une plaque (35a, 35b) respective, assemblée dans la station (12) de confection d'une manière amovible. 10
11. Machine selon la revendication 10, **caractérisée en ce que** les plaques (35a, 35b) sont interchangeables avec d'autres plaques ayant des éléments réchauffés (39) de forme ou dimensions différentes. 15
12. Machine selon l'une ou l'autre des revendications précédentes, **caractérisée en ce que** les pellicules (27, 28) superposées ont une largeur différente, de façon à obtenir un bord (140) cachetable sur un troisième côté des enveloppes (40). 20
13. Machine selon l'une ou l'autre des revendications précédentes, **caractérisée en ce que** des stations supplémentaires (13-16) peuvent être insérées sélectivement en aval de la station (12) de confection, et **en ce que** un groupe d'avance (19) est apte à déplacer les pinceaux d'une des stations (13-16) à l'autre. 25
30
14. Machine selon la revendication 13, **caractérisée en ce que** les stations supplémentaires comprennent une station (13) pour contrôler le positionnement des enveloppes (40) sur les pinceaux (18) respectifs, une station (14) pour compléter les enveloppes (40), une station de découpage (15) et une station de finissage (16) pour finir les enveloppes (40). 35
40
15. Machine selon la revendication 14, **caractérisée en ce que** le groupe d'avance (19) est constitué de moyens de tirage flexibles (21) fermés en anneau, desquels sont solitaires des éléments de positionnement et blocage (20) à des distances définies l'un de l'autre, les éléments de positionnement et blocage (20) étant aptes à coopérer temporairement avec la manche (22) du pinceau (18). 45
50
55

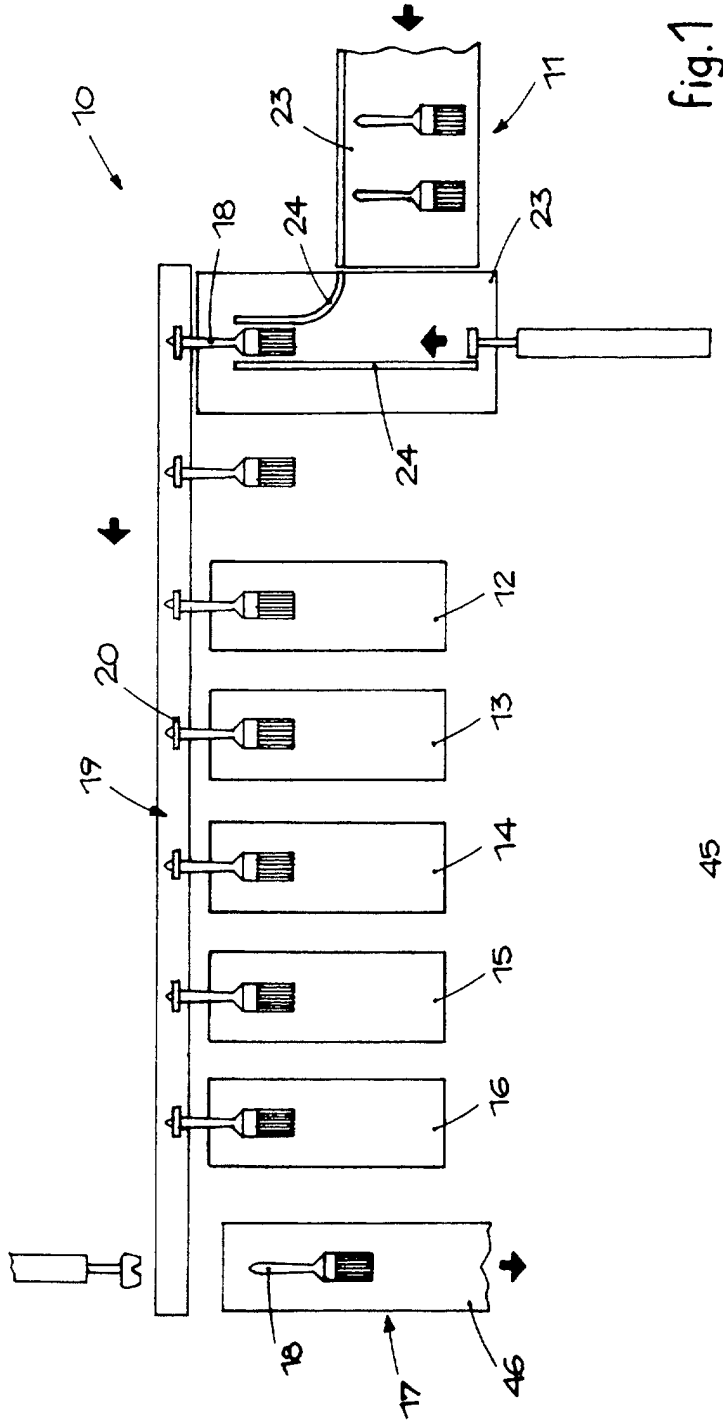

Fig. 1

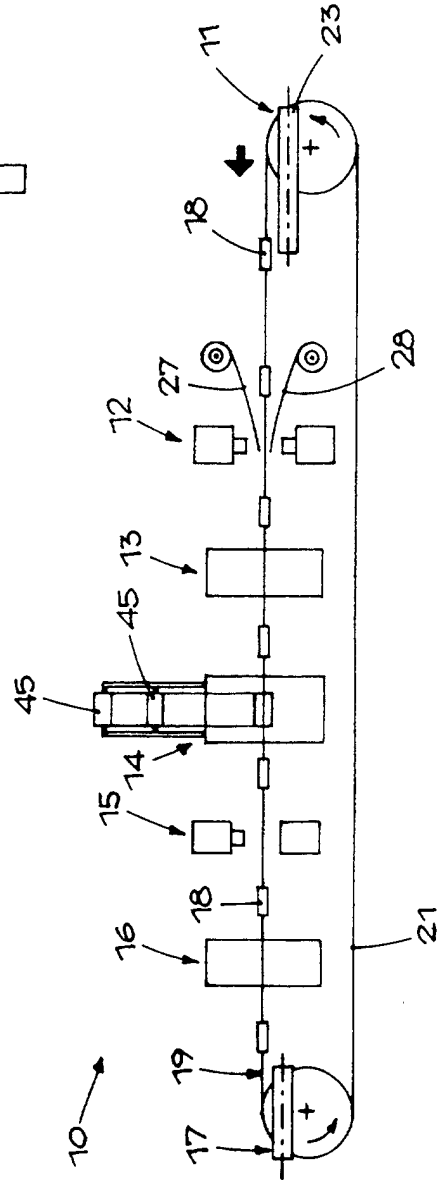

Fig. 2

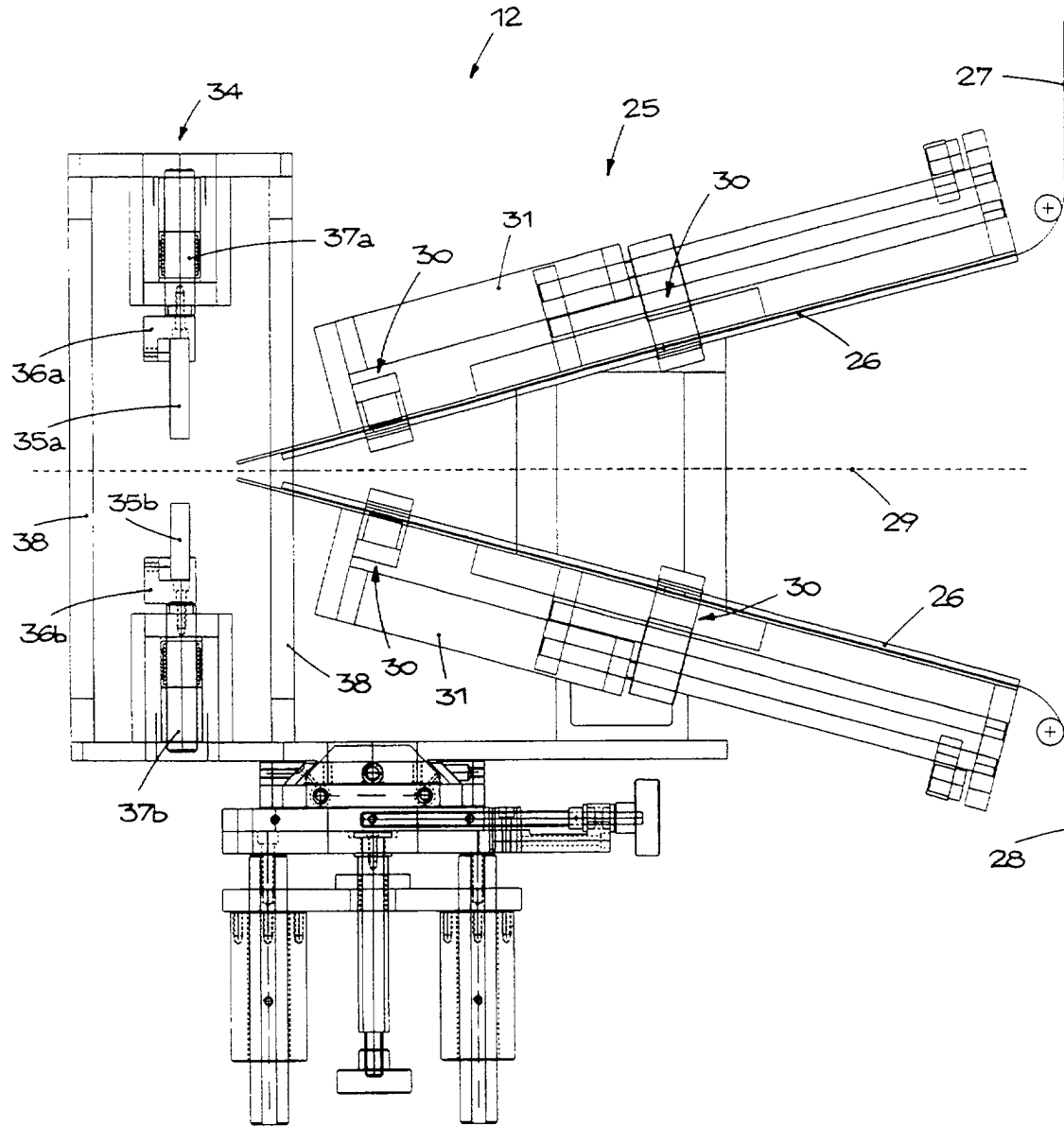

fig.3

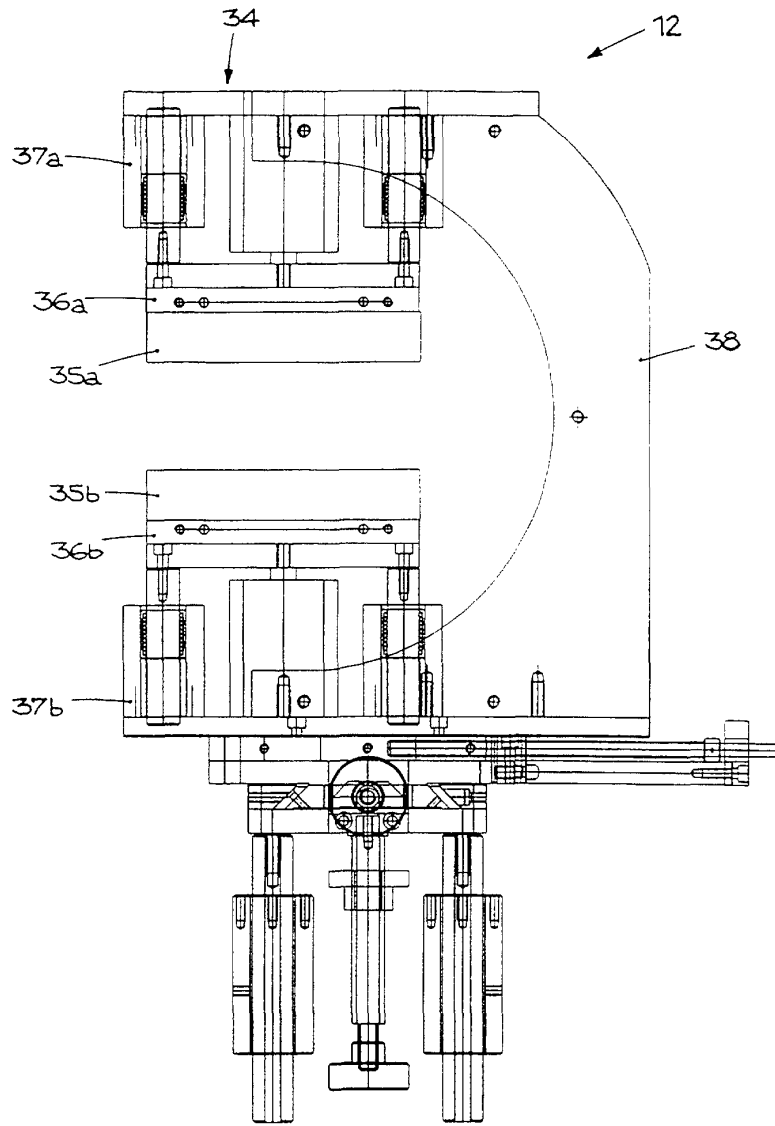

fig.4

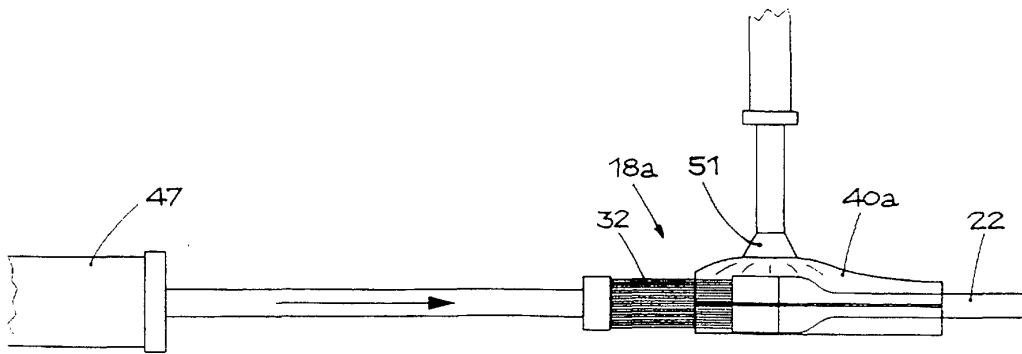

fig.13

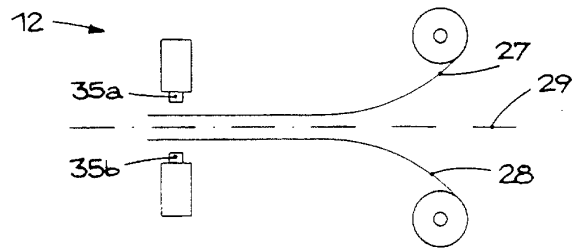

fig. 5a

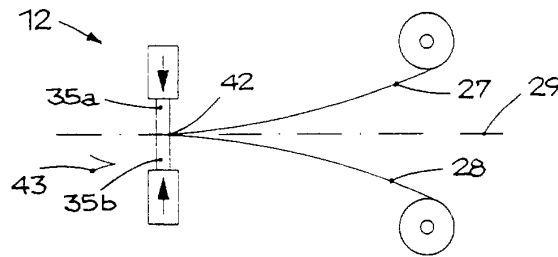

fig. 5b

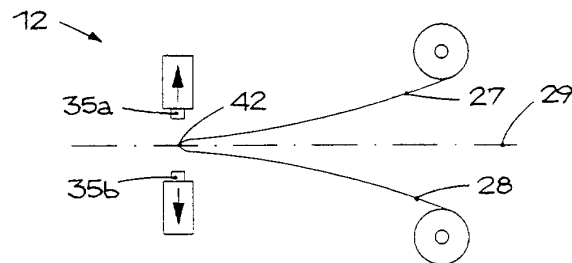

fig. 5c

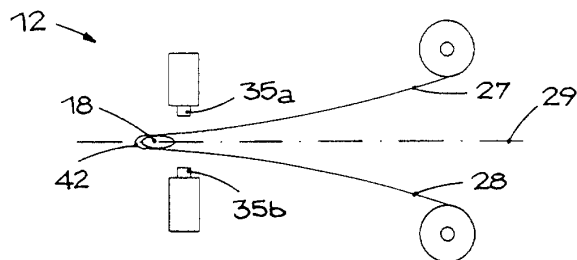

fig. 5d

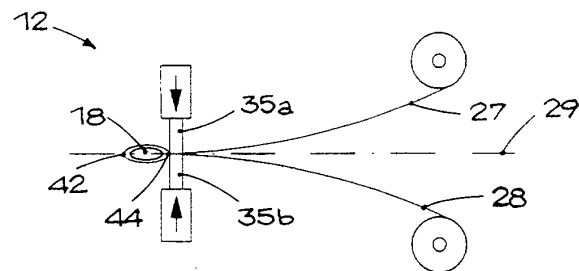

fig. 5e

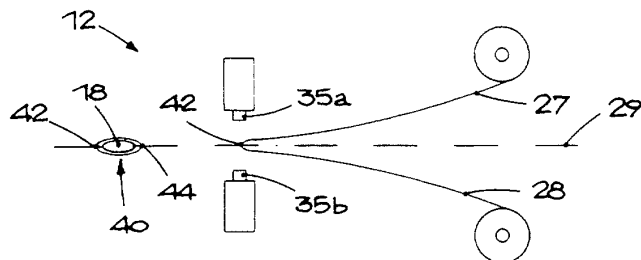

fig. 5f

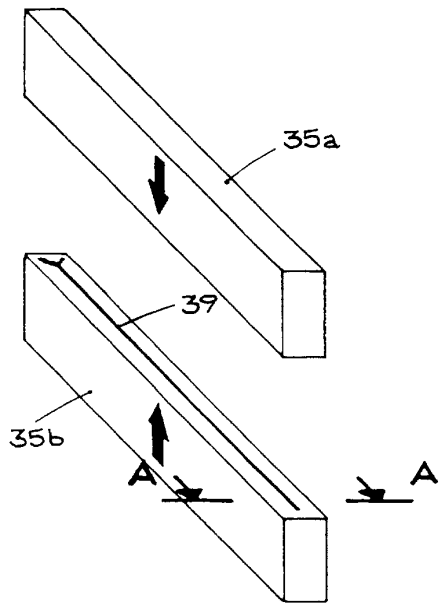

fig.6

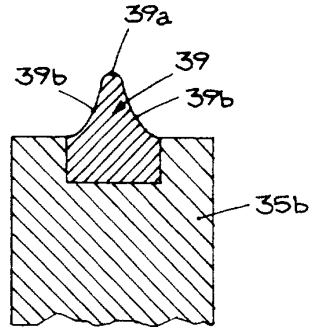

fig.7

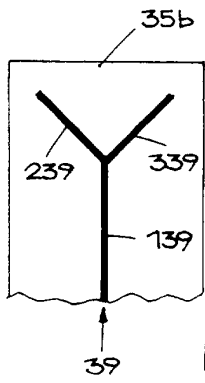

fig.9

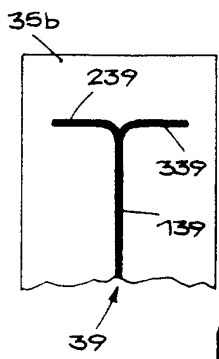

fig.10

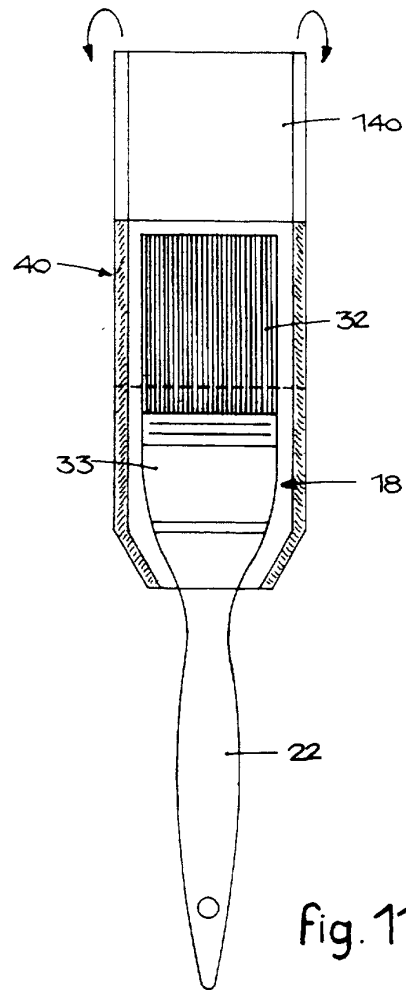

fig.11

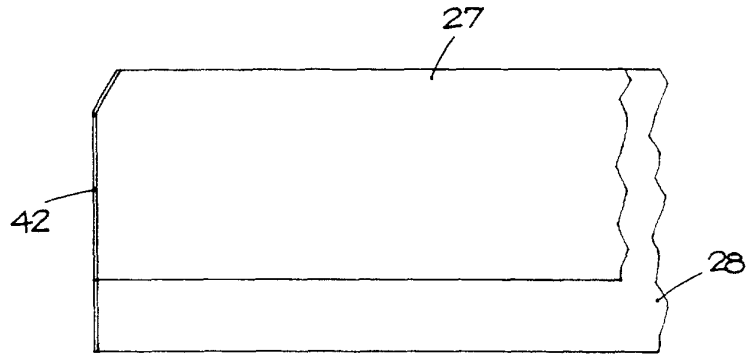

fig. 8a

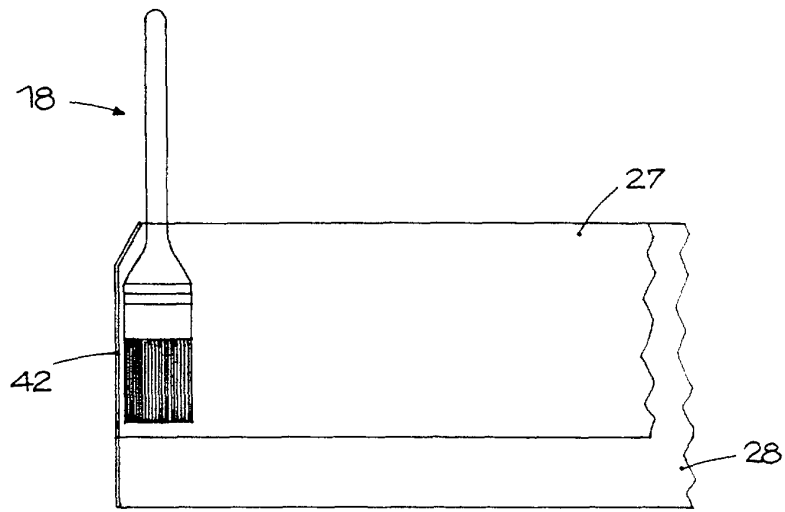

fig. 8b

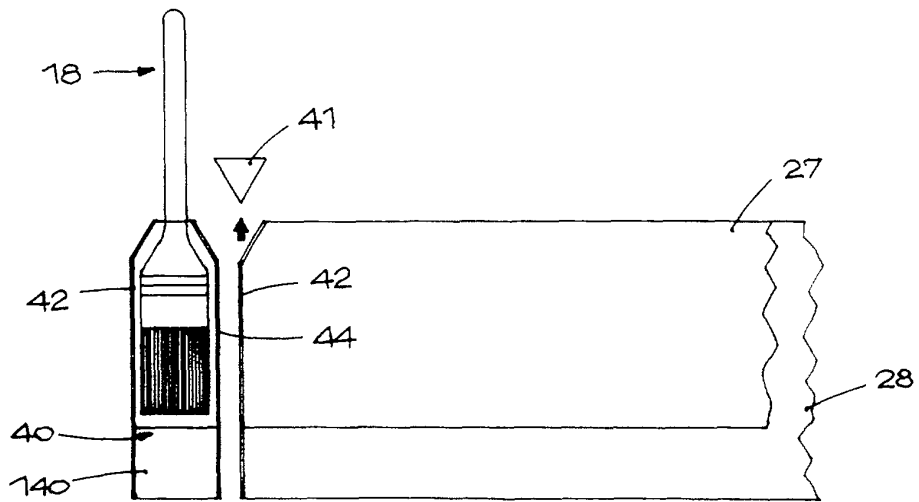

fig. 8c

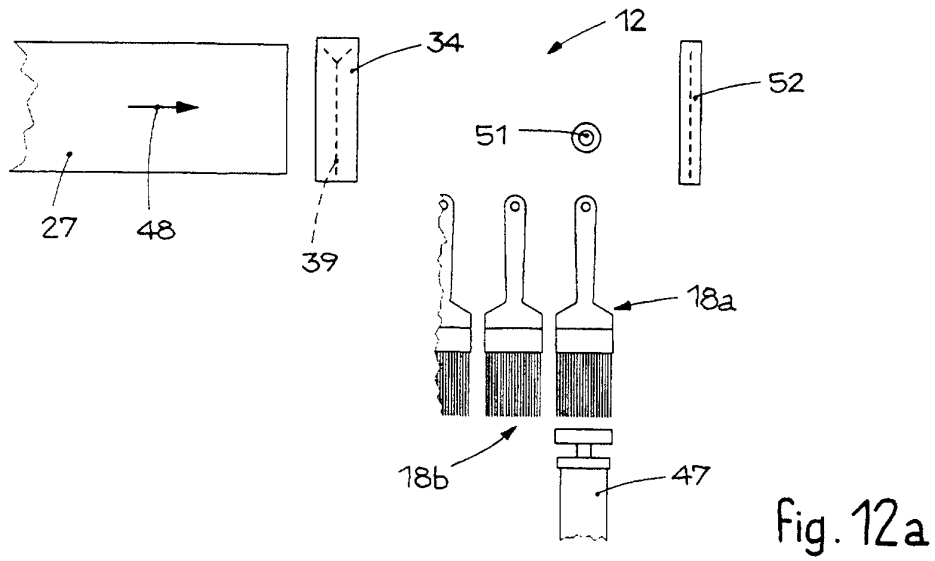

fig. 12a

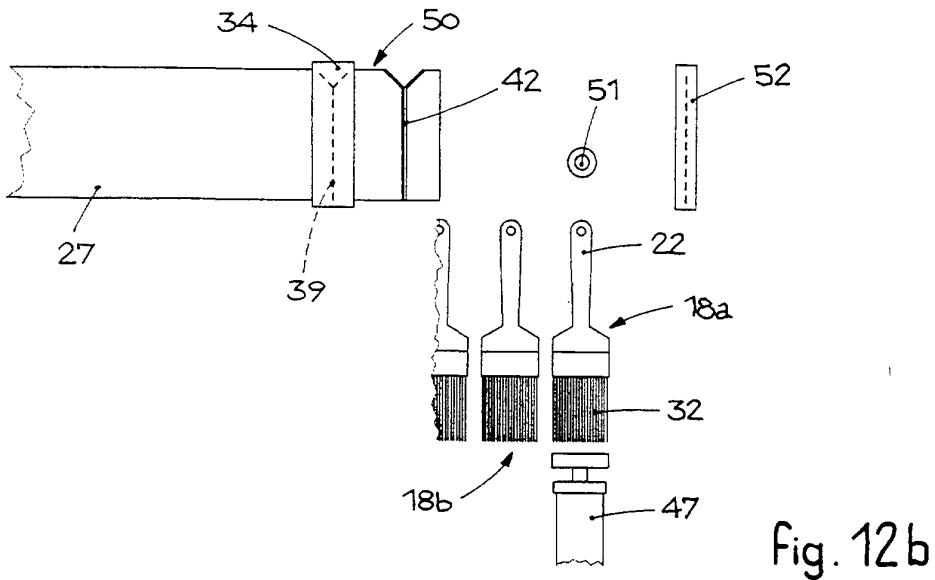

fig. 12b

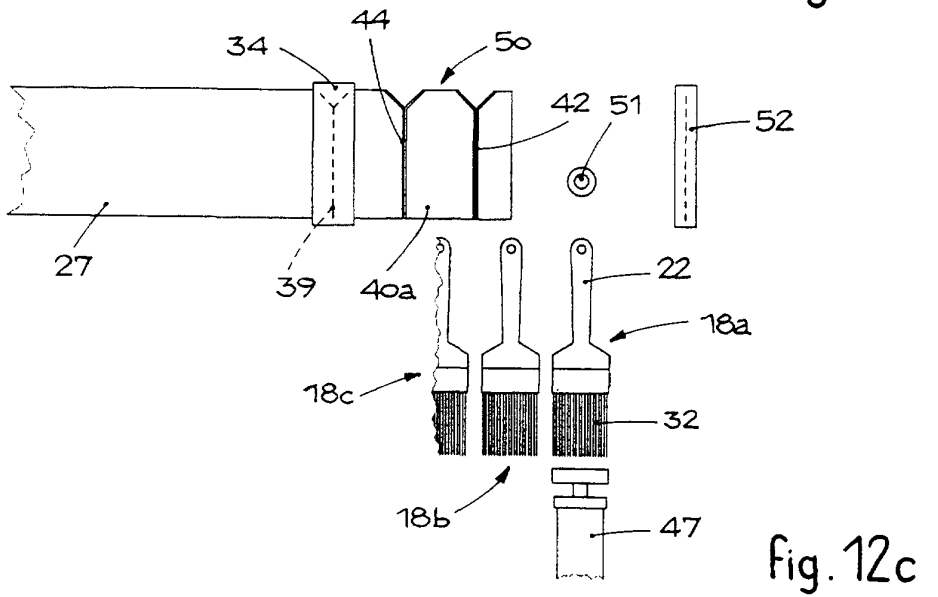

fig. 12c

