



Europäisches Patentamt
European Patent Office
Office européen des brevets



(11) **EP 0 967 152 B1**

(12) **EUROPEAN PATENT SPECIFICATION**

(45) Date of publication and mention
of the grant of the patent:
23.07.2003 Bulletin 2003/30

(51) Int Cl.7: **B65D 5/20**

(21) Application number: **99201698.0**

(22) Date of filing: **31.05.1999**

(54) **Blank for manufacturing a box and a box**

Zuschnitt zur Herstellung einer Schachtel und Schachtel

Flan destiné à la fabrication d'une boîte et boîte

(84) Designated Contracting States:
BE DE DK ES FR GB NL

(30) Priority: **23.06.1998 NL 1009469**

(43) Date of publication of application:
29.12.1999 Bulletin 1999/52

(73) Proprietor: **GSF Verpakkingen B.V.**
9665 PX Oude Pekela (NL)

(72) Inventor: **Van Eijndhoven, Peter Paul**
3771 JW Barneveld (NL)

(74) Representative: **Ferguson, Alexander et al**
Octrooibureau Vriesendorp & Gaade,
P.O. Box 266
2501 AW Den Haag (NL)

(56) References cited:
FR-A- 1 427 832 **FR-A- 2 242 872**
FR-A- 2 306 888 **FR-A- 2 691 443**
GB-A- 1 389 711 **GB-A- 2 300 179**
NL-C- 1 002 381

EP 0 967 152 B1

Note: Within nine months from the publication of the mention of the grant of the European patent, any person may give notice to the European Patent Office of opposition to the European patent granted. Notice of opposition shall be filed in a written reasoned statement. It shall not be deemed to have been filed until the opposition fee has been paid. (Art. 99(1) European Patent Convention).

Description

[0001] The present invention relates to a blank for the manufacturing of a box and to a box with one pair of hollow side walls made from such a blank.

[0002] Such a box is known from European patent application 0 731 032. As a result of the one pair of hollow side walls, which are placed at sufficient distance from each other, said box apart from a heat-insulating function also has a bearing function, so that the box is also suitable for the transport and temporary storage of perishable foodstuffs such as for instance fish. However when the insulating function is not wanted, the hollow side wall take up considerable space. The distance between the hollow side walls could then be made smaller, which however reduces the bearing ability considerably, so that a wanted strength of stacking with dynamic loads cannot be obtained.

[0003] The object of the invention is to provide a blank for manufacturing a box and a box with sufficient strength of stacking with dynamic loads at reduced distance between the hollow side walls.

[0004] To that end according to the present invention a blank is provided for manufacturing a box, the blank being provided with a bottom panel with a number of corners, with a first pair and a second pair of parallel side wall panels, each side wall panel of the first pair being connected to the bottom panel by one bottom folding line, and each side wall panel of the second pair being connected to the bottom panel by one bottom folding line, and each side wall panel having end edges which are transverse to the bottom folding line, a connection panel being connected to each of the side wall panels of the second pair via a first connection folding line, an additional side wall panel being connected to each of the connection panels via a second connection folding line, an attachment panel being connected to each of the additional side wall panels via a connection folding line, the first and second connection folding line and the attachment folding line running parallel to the bottom folding line, each additional side wall panel having an end edge formed by a first tube folding line, a first tube panel being connected to the additional side wall panel via the first tube folding line, a second tube panel being connected to the first tube panel via a second tube folding line, the first and second tube folding lines each being perpendicular to the bottom folding line, the end edge concerned of each side wall panel of the first pair being formed by a third tube folding line, via which tube folding line the side wall panel concerned of the first pair is connected to a third tube panel, a fourth tube panel being connected to the third tube panel via a fourth tube folding line, and a fifth tube panel being connected to the fourth tube panel via a fifth tube folding line, the third, fourth and fifth tube folding line each being perpendicular to the bottom folding line, the third, fourth and fifth tube panels and the third, fourth and fifth tube folding lines being arranged and designed such that after fold-

ing about the tube folding lines the tube panels form a reinforcement tube, enclosing a cavity of triangular cross-section, the fifth tube panel after folding being intended to be attached to the side wall panel of the first pair, the side wall panel of the second pair, the connection panel, the additional side wall panel and the first and second connection folding line and the attachment folding line being arranged and designed such that after folding about the attachment and connection folding lines the connection panel and the additional side wall panel form a hollow side wall, the attachment panel after folding being intended to be attached to the bottom panel, a part of the reinforcement tube with triangular cross-section extending into the hollow side wall, the first tube panel after folding being intended to be attached to the fourth tube panel and the second tube panel after folding being intended to be attached to the fifth tube panel. This blank according to the invention makes it possible to provide a box with a reinforcement tube of triangular cross-section near every corner of the box, which reinforcement tube is substantially perpendicular to the plane of the bottom. In this way, particularly because of the angle shape and the way of gluing the inner wall, the box acquires sufficient rigidity and in vertical direction sufficient strength to be stacked when filled, for instance to a stack with a height used for transport of such filled boxes in for instance a lorry or other means of transportation. Because the reinforcement tube encloses a triangular cavity, in other words an in cross-section closed figure, an extremely high strength of stacking is obtained.

[0005] An embodiment of the blank according to the invention wherein a grip panel is connected to a side wall panel concerned of the first pair via a grip folding line, the grip folding line being parallel to the bottom folding line, the grip panel after folding being intended to be attached to the side wall panel of the first pair, provides extra firmness to the side walls of the box that are intended to be provided with an opening serving as grip, as a result of which the life span of the box is increased.

[0006] A further embodiment of a blank according to the invention wherein a first tube cover flap is connected to a side wall panel concerned of the first pair via a first flap folding line, the first flap folding line being parallel to the bottom folding line, a second tube cover flap being connected to the first tube cover flap via a second flap folding line, the second flap folding line being perpendicular to the bottom folding line, the second tube cover flap after folding being intended to be attached to the side wall panel concerned of the second pair and the first tube cover flap being intended to cover the reinforcement tube, in all cases provides a sufficiently large supporting surface for a box to be stacked on a box made from the blank because of the first tube cover flap.

[0007] In order to facilitate the assembly and folding of the blank according to the invention each side wall panel of the first pair is provided with a first bevel near each corner and the fifth tube panel concerned is pro-

vided with a second bevel with a same angle as the first bevel, the first and second bevel being adjacent after folding.

[0008] The invention also relates to a box with one pair of hollow side walls made from a blank according to the invention, provided with a bottom panel with a first pair and a second pair of parallel side wall panels, each side wall panel of the first pair being connected to the bottom panel by one bottom folding line, and each side wall panel of the second pair being connected to the bottom panel by one bottom folding line, and each side wall panel having end edges which are transverse to the bottom folding line, a connection panel being connected to each of the side wall panels of the second pair via a first connection folding line, an additional side wall panel being connected to each of the connection panels via a second connection folding line, an attachment panel being connected to each of the additional side wall panels via a connection folding line, the first and second connection folding line and the attachment folding line running parallel to the bottom folding line, each additional side wall panel having an end edge formed by a first tube folding line, a first tube panel being connected to the additional side wall panel via the first tube folding line, a second tube panel being connected to the first tube panel via a second tube folding line, the first and second tube folding line each being perpendicular to the bottom folding line, the end edge concerned of each side wall panel of the first pair being formed by a third tube folding line, via which tube folding line the side wall panel concerned of the first pair is connected to a third tube panel, the fourth tube panel being connected to the third tube panel via a fourth tube folding line, and a fifth tube panel being connected to the fourth tube panel via a fifth tube folding line, the third, fourth and fifth tube folding lines each being perpendicular to the bottom folding line, the third, fourth and fifth tube panels forming a reinforcement tube, enclosing a cavity of triangular cross-section, the fifth tube panel being attached to the side wall panel of the first pair, each of the second pair of side wall panels, the connection panel, and the additional side wall panel forming a hollow side wall, the attachment panel being attached to the bottom panel, a part of the reinforcement tube with triangular cross-section extending into the hollow side wall, and the first tube panel being attached to the fourth tube panel and the second tube panel being attached to the fifth tube panel.

[0009] Some embodiments of a blank and a box according to the present invention will by way of example be elucidated on the basis of a drawing in which:

Figure 1 shows a part of the blank according to the invention;

Figure 2 shows a part of a box with one pair of hollow side walls according to the invention;

Figure 3 shows a top view of figure 2 in which the

tube cover flaps are shown in folded away position in order to elucidate the reinforcement tube.

[0010] The blank and box according to the present invention will be described on the basis of one of the corners of the blank and box respectively. It will be clear however that the other corners of the blank and box are formed analogous to the corner shown in the figures and described below.

[0011] Figure 1 shows a part, namely a corner, of a blank for the manufacturing of a box. The blank is provided with a bottom panel 1 with a number of corners 2, of which only one is shown. Furthermore the blank comprises a first pair 3 and a second pair 4 of parallel side wall panels, each side wall panel 3 of the first pair being connected to the bottom panel 1 by one bottom folding line 5. Each side wall panel 4 of the second pair is connected to the bottom panel 1 by one bottom folding line 6. Each side wall panel 3, 4 has end edges 7 and 8 respectively which are transverse to the bottom folding line 5 and 6 respectively.

[0012] A connection panel 9 is connected to each of the side wall panels 4 of the second pair via a first connection folding line 10. An additional side wall panel 11 is connected to each of the connection panels 9 via a second connection folding line 12. An attachment panel 13 is connected to each of the additional side wall panels 11 via a connection folding line 14. The first and second connection folding line 10, 12 and the attachment folding line 14 here run parallel to the bottom folding line 6.

[0013] The end edge of each additional side wall panel 11 is formed by a first tube folding line 16. A first tube panel 15 is connected to the additional side wall panel 11 via the first tube folding line 16, a second tube panel 17 being connected to the first tube panel 15 via a second tube folding line 18. The first and second tube folding lines 16, 18 each are perpendicular to the bottom folding line 6. The end edge 7 concerned of each side wall panel 3 of the first pair is formed by a third tube folding line, via which tube folding line 7 the side wall panel 3 concerned of the first pair is connected to a third tube panel 19. A fourth tube panel 20 is connected to the third tube panel 19 via a fourth tube folding line 21. Furthermore a fifth tube panel 22 is connected to the fourth tube panel 20 via a fifth tube folding line 23. The third, fourth and fifth tube folding line 7, 21, 23 each are perpendicular to the bottom folding line 5.

[0014] The third, fourth and fifth tube panels 19, 20, 22 and the third, fourth and fifth tube folding lines 7, 21, 23 are arranged and designed such that after folding about the tube folding lines 7, 21, 23 the tube panels 19, 20, 22 form a reinforcement tube, enclosing a cavity of triangular cross-section. After folding the fifth tube panel 22 is intended to be attached to the side wall panel 3 of the first pair.

[0015] Furthermore the side wall panel 4 of the second pair, the connection panel 9, the additional side wall panel 11 and the first and second connection folding line

10, 12 and the attachment folding line 14 are arranged and designed such that after folding about the attachment and connection folding lines 10, 12, 14 the connection panel 9 and the additional side wall panel 11 form a hollow side wall of the box. After folding the attachment panel 13 is intended to be attached to the bottom panel. A part of the reinforcement tube with triangular cross-section extends into the hollow side wall for the provision of additional rigidity and stackability.

[0016] After folding the first tube panel 15 is intended to be attached to the fourth tube panel 20 and after folding the second tube panel 17 is intended to be attached to the fifth tube panel 22.

[0017] In order to be able to lift the box it is common to provide a box with grips. Preferably these grips are arranged in the side walls that are not hollow. In order to provide these side walls and as a result the box itself as well, with more rigidity and bearing capacity a grip panel 24 is connected to a side wall panel 3 concerned of the first pair via a grip folding line 25. Said grip folding line 25 is parallel to the bottom folding line 5. After folding the grip panel 24 is attached to the side wall panel 3 of the first pair.

[0018] In order to prevent unwanted that material ends up in the reinforcement tube and to provide a supporting surface for a box which can be stacked on the box to be made from the blank, a first tube cover flap 26 is connected to a side wall panel 3 concerned of the first pair via a first flap folding line 27, and a second tube cover flap 28 is connected to the first tube cover flap 26 via a second flap folding line 29. The second flap folding line 29 is perpendicular to the bottom folding line 5, and the first flap folding line 27 is parallel to the bottom folding line 5. After folding the second tube cover flap 28 is attached to the side wall panel 4 concerned of the second pair and the first tube cover flap 26 covers the reinforcement tube.

[0019] In order to let the folding of the blank according to the invention into a box take place in a reproducible manner each side wall panel 3 of the first pair is provided with a first bevel 30 near each corner and the fifth tube panel 22 concerned is provided with a second bevel 31 with a same angle as the first bevel 30. When folding the first and second bevel 30, 31 have to be placed such that they are adjacent to each other.

[0020] A box is folded from the a blank according to the invention in the following manner.

[0021] First of all the side wall panel 3 of the first pair including the tube panels, the tube cover flaps and possibly the grip panel are folded about the bottom folding line until the side wall panel 3 is more or less transverse to the bottom panel 1. After that the third tube panel 19 is folded about the third folding line 7 until the third tube panel 19 is transverse to the side wall panel 3 of the first pair and situated above the bottom panel 2. Subsequently the fifth tube panel 22 is taken hold of and placed against the side wall panel 3 of the first pair and attached thereto, for instance by means of glue that was arranged

in advance on the fifth tube panel 22 and/or the side wall panel 3. In all cases accurate and reproducible placement and attachment of the fifth tube panel 22 to the side wall panel 3 of the first pair is obtained by letting the preferably provided bevels 30 and 31 be adjacent after folding. In this way the reinforcement tube enclosing a cavity of triangular cross-section, is formed as can be seen in figures 2 and 3.

[0022] When a grip panel 24 is present it is subsequently folded about the grip folding line 24 until it abuts the side wall panel 3 of the first pair. Preferably the dimensions of the fifth tube panel 22 are chosen such that in addition a part of the fifth tube panel 22 is situated in between the grip panel 24 and the side wall panel 3 of the first pair. The grip panel 24 is attached to the side wall panel 3 of the first pair and possibly to the fifth tube panel 22 by gluing.

[0023] After that the side wall panel 4 of the second pair is folded about the bottom folding line 6, until the side wall panel 4 is transverse to the bottom panel 1. Subsequently the connection panel 9 is folded about the first connection folding line 10 until the connection folding line 9 is transverse to the side wall panel 4 of the second pair. Here the connection panel 9 is situated above the bottom panel 1 and covers a part of the reinforcement tube with an end portion. Then the additional side wall panel 11 is folded about the second connection folding line 12 until the additional side wall panel 11 is parallel to the side wall panel 4 of the second pair. The attachment panel 13 is folded about the attachment folding line 14 and attached to the bottom panel 1 by means of glue. After that the first tube panel 15 is folded about the first tube folding line 16 and the second tube panel 17 is folded about the second tube folding line 18 until the first tube panel 15 is pressed against the fourth tube panel 20 and the second tube panel 17 is pressed against to the fifth tube panel 21 and attached thereto, for instance by means of glue that has been applied on them in advance.

[0024] Finally the first tube cover flap 26 is folded about the first flap folding line 27 until the first tube cover flap 26 is transverse to the side wall panel 3 of the first pair and covers the reinforcement tube, and the second tube cover flap 28 is folded about the second flap folding line 29 until the tube cover flap 28 can be attached to the side wall panel 4 of the second pair by means of glue.

Claims

1. Blank for manufacturing a box, the blank being provided with a bottom panel (1) with a number of corners (2), with a first pair (3) and a second pair (4) of parallel side wall panels, each side wall panel (3) of the first pair being connected to the bottom panel (1) by one bottom folding line (5), and each side wall panel (4) of the second pair being connected to the bottom panel (1) by one bottom folding line (6), and

each side wall panel (3, 4) having end edges (7 and 8 respectively) which are transverse to the bottom folding line (5 and 6 respectively),

a connection panel (9) being connected to each of the side wall panels (4) of the second pair via a first connection folding line (10), an additional side wall panel (11) being connected to each of the connection panels (9) via a second connection folding line (12),

an attachment panel (13) being connected to each of the additional side wall panels (11) via a connection folding line (14), the first and second connection folding line (10, 12) and the attachment folding line (14) running parallel to the bottom folding line (6), each additional side wall panel (11) having an end edge (16) formed by a first tube folding line, a first tube panel (15) being connected to the additional side wall panel (11) via the first tube folding line (16), a second tube panel (17) being connected to the first tube panel (15) via a second tube folding line (18), the first and second tube folding lines (16, 18) each being perpendicular to the bottom folding line (6),

the end edge (7) concerned of each side wall panel (3) of the first pair being formed by a third tube folding line, via which tube folding line (7) the side wall panel (3) concerned of the first pair is connected to a third tube panel (19), a fourth tube panel (20) being connected to the third tube panel (19) via a fourth tube folding line (21), and a fifth tube panel (22) being connected to the fourth tube panel (20) via a fifth tube folding line (23), the third, fourth and fifth tube folding line (7, 21, 23) each being perpendicular to the bottom folding line (5),

the third, fourth and fifth tube panels (19, 20, 22) and the third, fourth and fifth tube folding lines (7, 21, 23) being arranged and designed such that after folding about the tube folding lines (7, 21, 23) the tube panels (19, 20, 22) form a reinforcement tube, enclosing a cavity of triangular cross-section, the fifth tube panel (22) after folding being intended to be attached to the side wall panel (3) of the first pair, the side wall panel (4) of the second pair, the connection panel (9), the additional side wall panel (11) and the first and second connection folding line (10, 12) and the attachment folding line (14) being arranged and designed such that after folding about the attachment and connection folding lines (10, 12, 14) the connection panel (9) and the additional side wall panel (11) form a hollow side wall, the attachment panel (13) after folding being intended to be attached to the bottom panel, a part of the reinforcement tube with triangular cross-section extending into the hollow side wall,

the first tube panel (15) after folding being intended to be attached to the fourth tube panel (20) and the second tube panel (17) after folding being intended to be attached to the fifth tube panel (22).

2. Blank according to claim 1, wherein a grip panel (24) is connected to a side wall panel (3) concerned of the first pair via a grip folding line (25), the grip folding line (25) being parallel to the bottom folding line (5), the grip panel (24) after folding being intended to be attached to the side wall panel (3) of the first pair.

3. Blank according to claim 1 or 2, wherein a first tube cover flap (26) is connected to a side wall panel (3) concerned of the first pair via a first flap folding line (27), the first flap folding line (27) being parallel to the bottom folding line (5), a second tube cover flap (28) being connected to the first tube cover flap (26) via a second flap folding line (29), the second flap folding line (29) being perpendicular to the bottom folding line (5), the second tube cover flap (28) after folding being intended to be attached to the side wall panel (4) concerned of the second pair and the first tube cover flap (26) being intended to cover the reinforcement tube.

4. Blank according to claim 1, 2 or 3, wherein each side wall panel (3) of the first pair is provided with a first bevel (30) near each corner and the fifth tube panel (22) concerned is provided with a second bevel (31) with a same angle as the first bevel (30), the first and second bevel (30, 31) being adjacent after folding.

5. Box with one pair of hollow side walls made from a blank according to any one of the preceding claims, provided with a bottom panel (1) with a first pair (3) and a second pair (4) of parallel side wall panels, each side wall panel (3) of the first pair being connected to the bottom panel (1) by one bottom folding line (5), and each side wall panel (4) of the second pair being connected to the bottom panel (1) by one bottom folding line (6), and each side wall panel (3, 4) having end edges (7, 8) which are transverse to the bottom folding line (5 and 6 respectively), a connection panel (9) being connected to each of the side wall panels (4) of the second pair via a first connection folding line (10), an additional side wall panel (11) being connected to each of the connection panels (9) via a second connection folding line (12), an attachment panel (13) being connected to each of the additional side wall panels (11) via a connection folding line (14), the first and second connection folding line (10, 12) and the attachment folding line (14) running parallel to the bottom folding line (6), each additional side wall panel (11) having an end edge (16) formed by a first tube folding line, a first tube panel (15) being connected to the additional side wall panel (11) via the first tube folding line (16), a second tube panel (17) being connected to the first tube panel (15) via a second tube folding line

(18), the first and second tube folding line (16, 18) each being perpendicular to the bottom folding line (6),

the end edge concerned of each side wall panel (3) of the first pair being formed by a third tube folding line (7), via which tube folding line (7) the side wall panel concerned (3) of the first pair is connected to a third tube panel (19), the fourth tube panel (20) being connected to the third tube panel (19) via a fourth tube folding line (21), and a fifth tube panel (22) being connected to the fourth tube panel (20) via a fifth tube folding line (23), the third, fourth and fifth tube folding lines (7, 21, 23) each being perpendicular to the bottom folding line (5),

the third, fourth and fifth tube panels (19, 20, 22) forming a reinforcement tube, enclosing a cavity of triangular cross-section, the fifth tube panel (22) being attached to the side wall panel (3) of the first pair after folding, each of the second pair of side wall panels (4), the connection panel (9), and the additional side wall panel (11) forming a hollow side wall, the attachment panel (13) being attached to the bottom panel, a part of the reinforcement tube with triangular cross-section extending into the hollow side wall,

the first tube panel (15) being attached to the fourth tube panel (20) and the second tube panel (17) being attached to the fifth tube panel (22).

6. Box according to claim 5, wherein a grip panel (24) is connected to a side wall panel (3) concerned of the first pair via a grip folding line (25), the grip folding line (25) being parallel to the bottom folding line (5), the grip panel (24) being attached to the side wall panel (3) of the first pair.

7. Box according to claim 5 or 6, wherein the first tube cover flap (26) is connected to a side wall panel (3) concerned of the first pair via a first flap folding line (27), the first flap folding line (27) being parallel to the bottom folding line (5), a second tube cover flap (28) being connected to the first tube cover flap (26) via a second flap folding line (29), the second flap folding line (29) being perpendicular to the bottom folding line (5), the second tube cover flap (28) being attached to the side wall panel (4) concerned of the second pair and the first tube cover flap (26) covering the reinforcement tube.

8. Box according to claim 5, 6 or 7, wherein each side wall panel (3) of the first pair is provided with a first bevel (30) near each corner and the fifth tube panel (22) concerned being provided with a second bevel (31) with a same angle as the first bevel (30), the first and second bevel (30, 31) being adjacent.

Patentansprüche

1. Zuschnitt zur Herstellung einer Schachtel, wobei der Zuschnitt mit einer Bodenplatte (1) mit einer Anzahl Ecken (2), mit einem ersten Paar (3) und einem zweiten Paar (4) parallele Seitenwandplatten versehen ist, wobei jede Seitenwandplatte (3) des ersten Paares durch eine Bodenfaltlinie (5) mit der Bodenplatte (1) verbunden ist und wobei jede Seitenwandplatte (4) des zweiten Paares durch eine Bodenfaltlinie (6) mit der Bodenplatte (1) verbunden ist und jede Seitenwandplatte (3, 4) Endränder (7 beziehungsweise 8) hat, die quer auf der Bodenfaltlinie (5 beziehungsweise 6) stehen, wobei an jeder der Seitenwandplatten (4) des zweiten Paares eine Verbindungsplatte (9) über eine erste Verbindungsfaltlinie (10) verbunden ist, wobei an jeder der Verbindungsplatten (9) eine zusätzliche Seitenwandplatte (11) über eine zweite Verbindungsfaltlinie (12) verbunden ist, wobei an jeder der zusätzlichen Seitenwandplatten (11) eine Befestigungsplatte (13) über eine Befestigungsfaltlinie (14) verbunden ist, wobei die erste und zweite Verbindungsfaltlinie (10, 12) und die Befestigungsfaltlinie (14) parallel zu der Bodenfaltlinie (6) laufen, wobei jede zusätzliche Seitenwandplatte (11) einen durch eine erste Rohrfaltlinie gebildeten Endrand (16) hat, wobei eine erste Rohrplatte (15) über die erste Rohrfaltlinie (16) mit der zusätzlichen Seitenwandplatte (11) verbunden ist, wobei eine zweite Rohrplatte (17) über eine zweite Rohrfaltlinie (18) mit der ersten Rohrplatte (15) verbunden ist, wobei die ersten und zweiten Rohrfaltlinien (16, 18) jede senkrecht auf der Bodenfaltlinie (6) stehen, wobei der betreffende Endrand (7) von jeder Seitenwandplatte (3) des ersten Paares durch eine dritte Rohrfaltlinie gebildet wird, über welche Rohrfaltlinie (7) die betreffende Seitenwandplatte (3) des ersten Paares mit einer dritten Rohrplatte (19) verbunden ist, wobei eine vierte Rohrplatte (20) über eine vierte Rohrfaltlinie (21) mit der dritten Rohrplatte (22) verbunden ist, und wobei eine fünfte Rohrplatte (22) über eine fünfte Rohrfaltlinie (23) mit der vierten Rohrplatte (20) verbunden ist, wobei die dritte, vierte und fünfte Rohrfaltlinie (7, 21, 23) jede senkrecht auf der Bodenfaltlinie (5) stehen, wobei die dritten, vierten und fünften Rohrplatten (19, 20, 22) und die dritten, vierten und fünften Rohrfaltlinien (7, 21, 23) derartig angeordnet und gebildet sind, daß nach Faltung um die Rohrfaltlinien (7, 21, 23) die Rohrplatten (19, 20, 22) ein Verstärkungsrohr, das einen Hohlraum mit dreieckigem Durchschnitt umschließt, bilden, wobei die fünfte Rohrplatte (22) nach Faltung bestimmt ist an der Seitenwandplatte (3) des ersten Paares befestigt zu werden, wobei die Seitenwandplatte (4) des zweiten Paares,

- die Verbindungsplatte (9), die zusätzliche Seitenwandplatte (11) und die erste und zweite Verbindungsfaltlinie (10, 12) und die Befestigungsfaltlinie (14) derartig angeordnet und gebildet sind, daß nach Faltung um die Befestigungs- und Verbindungsfalllinien (10, 12, 14) die Verbindungsplatte (9) und die zusätzliche Seitenwandplatte (11) eine hohle Seitenwand bilden, wobei die Befestigungsplatte (13) nach Faltung bestimmt ist an der Bodenplatte befestigt zu werden, wobei ein Teil des Verstärkungsrohrs mit dreieckigem Durchschnitt sich bis in die hohle Seitenwand erstreckt, wobei die erste Rohrplatte (15) nach Faltung bestimmt ist an der vierten Hohlplatte (20) befestigt zu werden und die zweite Rohrplatte (17) nach Faltung bestimmt ist an der fünften Rohrplatte (20) befestigt zu werden.
2. Zuschnitt nach Anspruch 1, wobei eine Handgriffplatte (24) über eine Handgriffaltlinie (25) mit einer betreffenden Seitenwandplatte (3) des ersten Paares verbunden ist, wobei die Handgriffaltlinie (25) parallel zu der Bodenfalllinie (5) ist, wobei die Handgriffplatte (24) nach Faltung bestimmt ist an der Seitenwandplatte (3) des ersten Paares befestigt zu werden.
3. Zuschnitt nach Anspruch 1 oder 2, wobei eine erste Rohrbedeckungsklappe (26) über eine erste Klappenfalllinie (27) mit einer betreffenden Seitenwandplatte (3) des ersten Paares verbunden ist, wobei die erste Klappenfalllinie (27) parallel zu der Bodenfalllinie (5) ist, wobei eine zweite Rohrbedeckungsklappe (28) über eine zweite Klappenfalllinie (29) mit der ersten Rohrbedeckungsklappe (26) verbunden ist, wobei die zweite Klappenfalllinie (29) senkrecht auf der Bodenfalllinie (5) steht, wobei die zweite Rohrbedeckungsklappe (28) nach Faltung bestimmt ist an der betreffenden Seitenwandplatte (4) des zweiten Paares befestigt zu werden und die erste Rohrbedeckungsklappe (26) bestimmt ist das Verstärkungsrohr abzudecken.
4. Zuschnitt nach Anspruch 1, 2 oder 3, wobei jede Seitenwandplatte (3) des ersten Paares nahe jeder Ecke mit einer ersten Abschrägung (30) versehen ist und die betreffende fünfte Rohrplatte (22) mit einer zweiten Abschrägung (31) mit einem selben Winkel wie die erste Abschrägung (30) versehen ist, wobei nach Faltung die erste und zweite Abschrägung (30, 31) angrenzend sind.
5. Schachtel mit einem Paar hohle Seitenwände aus einem Zuschnitt nach einem der vorhergehenden Ansprüche hergestellt, mit einer Bodenplatte (1), mit einem ersten Paar (3) und einem zweiten Paar (4) parallele Seitenwandplatten versehen, wobei jede Seitenwandplatte (3) des ersten Paares durch eine Bodenfalllinie (5) mit der Bodenplatte (1) verbunden ist und wobei jede Seitenwandplatte (4) des zweiten Paares durch eine Bodenfalllinie (6) mit der Bodenplatte (1) verbunden ist und jede Seitenwandplatte (3, 4) Endränder (7,8) hat, die quer auf der Bodenfalllinie (5 beziehungsweise 6) stehen, wobei an jeder der Seitenwandplatten (4) des zweiten Paares eine Verbindungsplatte (9) über eine erste Verbindungsfaltlinie (10) verbunden ist, wobei an jeder der Verbindungsplatten (9) eine zusätzliche Seitenwandplatte (11) über eine zweite Verbindungsfaltlinie (12) verbunden ist, wobei an jeder der zusätzlichen Seitenwandplatten (11) eine Befestigungsplatte (13) über eine Befestigungsfaltlinie (14) verbunden ist, wobei die erste und zweite Verbindungsfaltlinie (10, 12) und die Befestigungsfaltlinie (14) parallel zu der Bodenfalllinie (6) laufen, wobei jede zusätzliche Seitenwandplatte (11) einen durch eine erste Rohrfaltlinie gebildeten Endrand (16) hat, wobei eine erste Rohrplatte (15) über die erste Rohrfaltlinie (16) mit der zusätzlichen Seitenwandplatte (11) verbunden ist, wobei eine zweite Rohrplatte (17) über eine zweite Rohrfaltlinie (18) mit der ersten Rohrplatte (15) verbunden ist, wobei die erste und zweite Rohrfaltlinie (16, 18) jede senkrecht auf der Bodenfalllinie (6) stehen, wobei der betreffende Endrand von jeder Seitenwandplatte (3) des ersten Paares durch eine dritte Rohrfaltlinie (7) gebildet wird, über welche Rohrfaltlinie (7) die betreffende Seitenwandplatte (3) des ersten Paares mit einer dritten Rohrplatte (19) verbunden ist, wobei eine vierte Rohrplatte (20) über eine vierte Rohrfaltlinie (21) mit der dritten Rohrplatte (19) verbunden ist, und wobei eine fünfte Rohrplatte (22) über eine fünfte Rohrfaltlinie (23) mit der vierten Rohrplatte (20) verbunden ist, wobei die dritten, vierten und fünften Rohrfaltlinien (7, 21, 23) jede senkrecht auf der Bodenfalllinie (5) stehen, wobei die dritten, vierten und fünften Rohrplatten (19, 20, 22) ein Verstärkungsrohr, das einen Hohlraum mit dreieckigem Durchschnitt umschließt, bilden, wobei die fünfte Rohrplatte (22) an der Seitenwandplatte (3) des ersten Paares befestigt ist, wobei jede des zweiten Paares Seitenwandplatten (4), die Verbindungsplatte (9), und die zusätzliche Seitenwandplatte (11) eine hohle Seitenwand bilden, wobei die Befestigungsplatte (13) an der Bodenplatte befestigt ist, wobei ein Teil des Verstärkungsrohrs mit dreieckigem Durchschnitt sich bis in die hohle Seitenwand erstreckt, wobei die erste Rohrplatte (15) an der vierten Rohrplatte (20) und die zweite Rohrplatte (17) an der fünften Rohrplatte (22) befestigt ist.
6. Schachtel nach Anspruch 5, wobei eine Handgriffplatte (24) über eine Handgriffaltlinie (25) mit einer

betreffenden Seitenwandplatte (3) des ersten Paars verbunden ist, wobei die Handgriffaltlinie (25) parallel zu der Bodenfalllinie (5) ist, wobei die Handgriffplatte (24) an der Seitenwandplatte (3) des ersten Paars befestigt ist.

7. Schachtel nach Anspruch 5 oder 6, wobei die erste Rohrbedeckungsklappe (26) über eine erste Klappenfalllinie (27) mit einer betreffenden Seitenwandplatte (3) des ersten Paars verbunden ist, wobei die erste Klappenfalllinie (27) parallel zu der Bodenfalllinie (5) ist, wobei eine zweite Rohrbedeckungsklappe (28) über eine zweite Klappenfalllinie mit der ersten Rohrbedeckungsklappe (26) verbunden ist, wobei die zweite Klappenfalllinie (29) senkrecht auf der Bodenfalllinie (5) steht, wobei die zweite Rohrbedeckungsklappe (28) an der betreffenden Seitenwandplatte (4) des zweiten Paars befestigt ist und die erste Rohrbedeckungsklappe (26) das Verstärkungsrohr abdeckt.
8. Schachtel nach Anspruch 5, 6 oder 7, wobei jede Seitenwandplatte (3) des ersten Paars nahe jeder Ecke mit einer ersten Abschrägung (30) versehen ist und die betreffende fünfte Rohrplatte (22) mit einer zweiten Abschrägung (31) mit einem selben Winkel wie die erste Abschrägung (30) versehen ist, wobei die erste und zweite Abschrägung (30, 31) angrenzend sind.

Revendications

1. Flan destiné à la fabrication d'une boîte, le flan étant proposé avec un panneau de fond (1) ayant un certain nombre de coins (2), présentant une première paire (3) et une deuxième paire (4) de panneaux latéraux parallèles, chaque panneau latéral (3) de la première paire étant relié au panneau de fond (1) par une ligne de pliage de fond (5), et chaque panneau latéral (4) de la deuxième paire étant relié au panneau de fond (1) par une ligne de pliage de fond (6), et chaque panneau latéral (3, 4) présentant des arêtes terminales (7 et 8 respectivement) qui sont transversales par rapport à la ligne de pliage de fond (5 et 6 respectivement),
- un panneau de connexion (9) étant relié à chacun des panneaux latéraux (4) de la deuxième paire par l'intermédiaire d'une première ligne de pliage de connexion (10), un panneau latéral supplémentaire (11) étant relié à chacun des panneaux de connexion (9) par l'intermédiaire d'une deuxième ligne de pliage de connexion (12),
- un panneau de fixation (13) étant relié à chacun des panneaux latéraux supplémentaires (11) par l'intermédiaire d'une ligne de pliage de connexion (14), la première et la deuxième lignes de pliage de connexion (10, 12) et la ligne de pliage de

fixation (14) courant parallèlement à la ligne de pliage de fond (6),

chaque panneau latéral supplémentaire (11) possédant une arête terminale (16) formée par une première ligne de pliage en tube, un premier panneau en tube (15) étant relié au panneau latéral supplémentaire (11) par l'intermédiaire de la première ligne de pliage en tube (16), un deuxième panneau en tube (17) étant relié au premier panneau en tube (15) par l'intermédiaire d'une deuxième ligne de pliage en tube (18), la première et la deuxième lignes de pliage en tube (16, 18) étant chacune perpendiculaire à la ligne de pliage de fond (6),

l'arête terminale (7) concernée de chaque panneau latéral (3) de la première paire étant formée par une troisième ligne de pliage en tube, par l'intermédiaire de laquelle ligne de pliage en tube (7) le panneau latéral (3) concerné de la première paire est relié à un troisième panneau en tube (19), un quatrième panneau en tube (20) étant relié au troisième panneau en tube (19) par l'intermédiaire d'une quatrième ligne de pliage en tube (21) et un cinquième panneau en tube (22) étant relié au quatrième panneau en tube (20) par l'intermédiaire d'une cinquième ligne de pliage en tube (23), les troisième, quatrième et cinquième lignes de pliage en tube (7, 21, 23) étant chacune perpendiculaires à la ligne de pliage de fond (5),

les troisième, quatrième et cinquième panneaux en tube (19, 20, 22) et les troisième, quatrième, cinquième lignes de pliage en tube (7, 21, 23) étant agencés et conçus de manière à ce qu'après le pliage autour des lignes de pliage en tube (7, 21, 23) les panneaux en tube (19, 20, 22) forment un tube de renforcement, enfermant une cavité de coupe transversale triangulaire, le cinquième panneau en tube (22) après que l'objet du pliage soit d'être fixé au panneau latéral (3) de la première paire,

le panneau latéral (4) de la deuxième paire, le panneau de connexion (9), le panneau latéral supplémentaire (11) et les première et deuxième lignes de pliage de connexion (10, 12) et la ligne de pliage de fixation (14) étant agencés et conçus de manière à ce qu'après le pliage autour des lignes de pliage de fixation et de connexion (10, 12, 14), le panneau de connexion (9) et le panneau latéral supplémentaire (11) forment un panneau latéral creux, le panneau de fixation (13) après que l'objet du pliage soit d'être fixé au panneau de fond, une partie du tube de renforcement avec la coupe transversale triangulaire s'étendant à l'intérieur de la paroi latérale creuse,

le premier panneau en tube (15) après que l'objet du pliage soit d'être fixé au quatrième panneau en tube (20) et le deuxième panneau en tube (17) après que l'objet du pliage soit d'être fixé au cinquième panneau en tube (22).

2. Flan selon la revendication 1, dans lequel un panneau de préhension (24) est relié à un panneau latéral (3) concerné de la première paire par l'intermédiaire d'une ligne de pliage de préhension (25), la ligne de pliage de préhension (25) étant parallèle à la ligne de pliage de fond (5), le panneau de préhension (24) après que l'objet du pliage soit d'être fixé au panneau latéral (3) de la première paire.
3. Flan selon la revendication 1 ou 2, dans lequel un premier rabat de couvercle de tube (26) est relié à un panneau latéral (3) concerné de la première paire par l'intermédiaire d'une première ligne de pliage à rabat (27), la première ligne de pliage à rabat (27) étant parallèle à la ligne de pliage de fond (5), un deuxième rabat de couvercle de tube (28) étant relié au premier rabat de couvercle de tube (26) par l'intermédiaire d'une deuxième ligne de pliage à rabat (29), la deuxième ligne de pliage à rabat (29) étant perpendiculaire à la ligne de pliage de fond (5), le deuxième rabat de couvercle de tube (28) après que l'objet du pliage soit d'être fixé au panneau latéral (4) concerné de la deuxième paire et le premier rabat de couvercle de tube (26) dont l'objet est de couvrir le tube de renforcement.
4. Flan selon la revendication 1, 2 ou 3, dans lequel chaque panneau latéral (3) de la première paire est proposé avec un premier biseau (30) à proximité de chaque coin et le cinquième panneau en tube (22) concerné est proposé avec un deuxième biseau (31) avec le même angle que le premier biseau (30), le premier et le deuxième biseaux (30, 31) étant adjacents après le pliage.
5. Boîte avec une paire de parois latérales creuses composées à partir d'un flan selon l'une quelconque des revendications précédentes, proposée avec un panneau de fond (1) avec une première paire (3) et une deuxième paire (4) de panneaux latéraux parallèles, chaque panneau latéral (3) de la première paire étant relié au panneau de fond (1) par une ligne de pliage de fond (5) et chaque panneau latéral (4) de la deuxième paire étant relié au panneau de fond (1) par une ligne de pliage de fond (6) et chaque panneau latéral (3, 4) possédant des arêtes terminales (7, 8) qui sont transversales par rapport à la ligne de pliage de fond (5 et 6 respectivement), un panneau de connexion (9) étant relié à chacun des panneaux latéraux (4) de la deuxième paire par l'intermédiaire d'une première ligne de pliage de connexion (10), un panneau latéral supplémentaire (11) étant relié à chacun des panneaux de connexion (9) par l'intermédiaire d'une deuxième ligne de pliage de connexion (12), un panneau de fixation (13) étant relié à chacun des panneaux latéraux supplémentaires (11) par l'intermédiaire d'une ligne de pliage de connexion (14), la première et la deuxième lignes de pliage de connexion (10, 12) et la ligne de pliage de fixation (14) courant parallèlement à la ligne de pliage de fond (6),
- chaque panneau latéral supplémentaire (11) possédant une arête terminale (16) formée par une première ligne de pliage en tube, un premier panneau en tube (15) étant relié au panneau latéral supplémentaire (11) par l'intermédiaire de la première ligne de pliage en tube (16), un deuxième panneau en tube (17) étant relié au premier panneau en tube (15) par l'intermédiaire d'une deuxième ligne de pliage en tube (18), la première et la deuxième lignes de pliage en tube (16, 18) étant chacune perpendiculaires à la ligne de pliage de fond (6),
- l'arête terminale concernée de chaque panneau latéral (3) de la première paire étant formée par une troisième ligne de pliage en tube (7), par l'intermédiaire de laquelle ligne de pliage en tube (7) le panneau latéral (3) concerné de la première paire est relié à un troisième panneau en tube (19), le quatrième panneau en tube (20) étant relié au troisième panneau en tube (19) par l'intermédiaire d'une quatrième ligne de pliage en tube (21) et un cinquième panneau en tube (22) étant relié au quatrième panneau en tube (20) par l'intermédiaire d'une cinquième ligne de pliage en tube (23), les troisième, quatrième et cinquième lignes de pliage en tube (7, 21, 23) étant chacune perpendiculaires à la ligne de pliage de fond (5),
- les troisième, quatrième et cinquième panneaux en tube (19, 20, 22) formant un tube de renforcement, enfermant une cavité de coupe transversale triangulaire, le cinquième panneau en tube (22) étant fixé au panneau latéral (3) de la première paire après le pliage, chacun de la deuxième paire de panneaux latéraux (4), le panneau de connexion (9) et le panneau latéral supplémentaire (11) formant une paroi latérale creuse, le panneau de fixation (13) étant fixé au panneau de fond, une partie du tube de renforcement avec une coupe transversale triangulaire s'étendant dans la paroi latérale creuse,
- le premier panneau en tube (15) étant fixé au quatrième panneau en tube (20) et le deuxième panneau en tube (17) étant fixé au cinquième panneau en tube (22).
6. Boîte selon la revendication 5, dans laquelle un panneau de préhension (24) est relié à un panneau latéral (3) concerné de la première paire par l'intermédiaire d'une ligne de pliage de préhension (25), la ligne de pliage de préhension (25) étant parallèle à la ligne de pliage de fond (5), le panneau de préhension (24) étant fixé au panneau latéral (3) de la première paire.

7. Boîte selon la revendication 5 ou 6, dans lequel un premier rabat de couvercle de tube (26) est relié à un panneau latéral (3) concerné de la première paire par l'intermédiaire d'une première ligne de pliage à rabat (27), la première ligne de pliage à rabat (27) étant parallèle à la ligne de pliage de fond (5), un deuxième rabat de couvercle de tube (28) étant relié au premier rabat de couvercle de tube (26) par l'intermédiaire d'une deuxième ligne de pliage à rabat (29), la deuxième ligne de pliage à rabat (29) étant perpendiculaire à la ligne de pliage de fond (5), le deuxième rabat de couvercle de tube (28) étant fixé au panneau latéral (4) concerné de la deuxième paire et le premier rabat de couvercle de tube (26) couvrant le tube de renforcement.
8. Boîte selon la revendication 5, 6 ou 7, dans lequel chaque panneau latéral (3) de la première paire est proposé avec un premier biseau (30) à proximité de chaque coin et le cinquième panneau en tube (22) concerné est proposé avec un deuxième biseau (31) avec le même angle que le premier biseau (30), le premier et le deuxième biseaux (30, 31) étant adjacents.

5

10

15

20

25

30

35

40

45

50

55

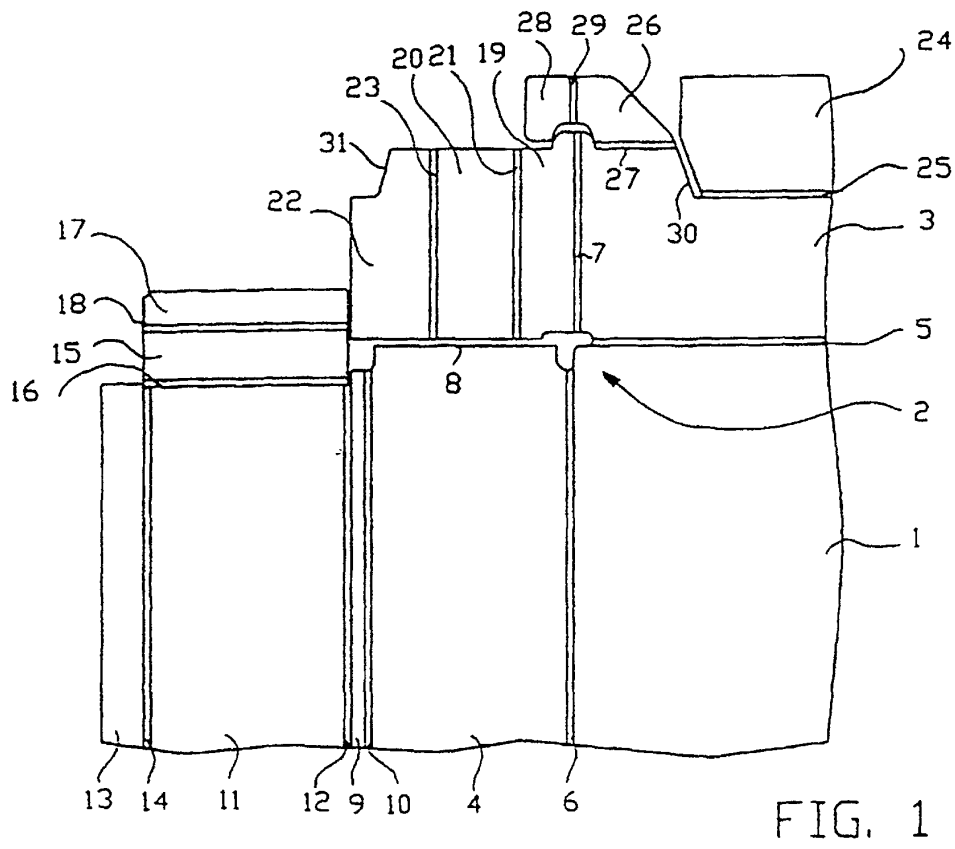
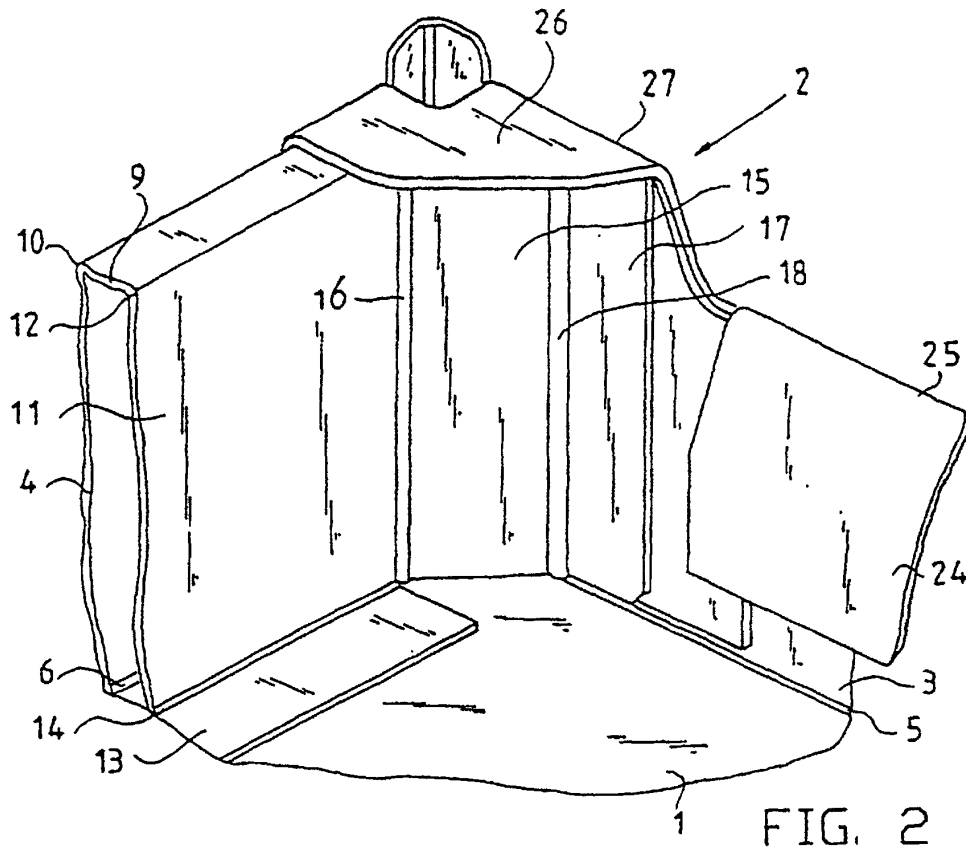

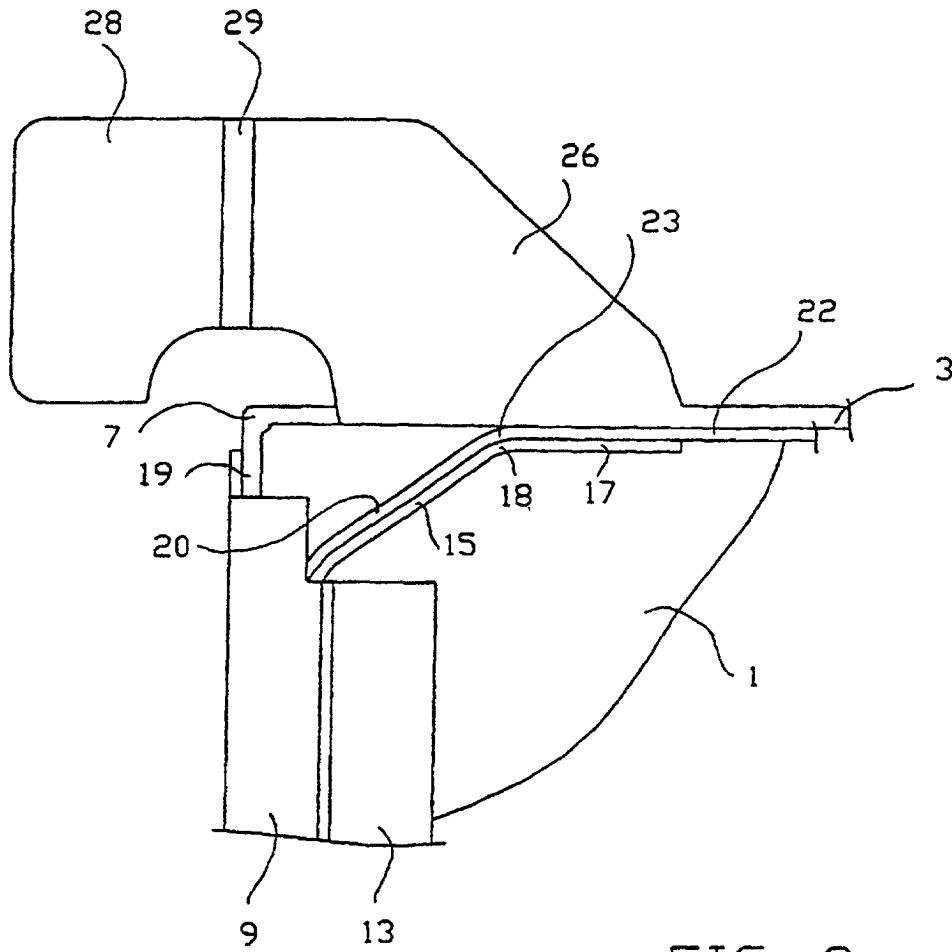

FIG. 3