



Europäisches Patentamt
European Patent Office
Office européen des brevets



(11) **EP 0 967 162 B1**

(12) **EUROPEAN PATENT SPECIFICATION**

(45) Date of publication and mention
of the grant of the patent:
07.11.2001 Bulletin 2001/45

(51) Int Cl.7: **B65F 3/00**, B65F 3/20,
B65F 3/28

(21) Application number: **98830370.7**

(22) Date of filing: **18.06.1998**

(54) **Method and apparatus for storing rubbish in a motor-vehicle intended for differentiated collection of the same**

Verfahren und Vorrichtung zum Lagern von Müll in einem für das getrennte Sammeln von Müll geeigneten Fahrzeug

Procédé et dispositif de stockage de déchets dans un véhicule destiné pour collecter séparément des déchets

(84) Designated Contracting States:
AT BE CH DE ES FR GB IT LI NL

(74) Representative: **Tansini, Elio Fabrizio et al**
c/o BUGNION S.p.A.
Viale Lancetti 17
20158 Milano (IT)

(43) Date of publication of application:
29.12.1999 Bulletin 1999/52

(56) References cited:
WO-A-97/45292 **US-A- 5 316 430**
US-A- 5 584 642

(73) Proprietor: **O.M.B. BRESCIA S.p.A.**
25135 Brescia (IT)

(72) Inventor: **Bragadina, Giovanni**
25060 Collebeato (Brescia) (IT)

EP 0 967 162 B1

Note: Within nine months from the publication of the mention of the grant of the European patent, any person may give notice to the European Patent Office of opposition to the European patent granted. Notice of opposition shall be filed in a written reasoned statement. It shall not be deemed to have been filed until the opposition fee has been paid. (Art. 99(1) European Patent Convention).

Description

[0001] The present invention relates to a method for storing rubbish on a motor vehicle intended for differentiated collection of the same, comprising the characteristics expressed in the preamble to claim 1.

[0002] The present invention also relates to an apparatus for storing rubbish on a motor vehicle intended for differentiated collection of the same, comprising the characteristics expressed in the preamble to claim 9.

[0003] As is well known, the differentiated collection of solid urban or other kinds of waste consists of collecting different types of waste, separately from each other, in such a way as to facilitate the disposal and/or recycling operations of the waste.

[0004] More specifically, waste is normally conveyed into collecting bins which are able to be periodically emptied onto motor vehicles intended for transportation of the waste itself to treatment and/or disposal locations.

[0005] For this purpose the use is known of motor vehicles provided with a holding container subdivided internal by a dividing baffle into an upper conveying chamber and a lower conveying chamber.

[0006] A hopper is fitted on the motor vehicle ahead of the holding container to convey inside the upper and lower conveying chambers, respectively, a first and a second type of waste emptied, simultaneously or in successive phases, from one or more of the aforesaid bins.

[0007] From the side opposite to the hopper, the holding container presents an outlet opening whereto is associated a closure door subdivided into an upper semi-part and a lower semi-part.

[0008] The upper semi-part of the closure door, hinged in the upper part of the holding container, can be opened independently from the lower semi-part, whereas the latter can only be opened together with the upper semi-part. The lower semi-part is opened with the aid of latching means which retain the semi-parts united together whilst lifting means act on the upper semi-part to lift the entire door.

[0009] The dividing baffle of the holding container presents a fixed portion which extends horizontally along the container itself and an orientable portion, hinged to the fixed portion on the side opposite to the hopper and presenting a terminal edge adjacent to an inner surface of the door. This inner surface develops according to an arched profile concentric to the hinge axis of the orientable portion.

[0010] Moreover, the orientable portion can be selectively placed in a position of coplanarity with the fixed portion or in a first and a second deviated position respectively opposite, wherein the orientable portion is set perpendicularly with respect to the fixed portion, thereby determining the increase in the capacity of one or the other conveying chambers.

[0011] In the coplanar position, the orientable portion divides the outlet opening into an upper portion and a lower portion communicating respectively with the up-

per semi-part and the lower semi-part of the closure door. When the orientable portion of the dividing baffle is set in the first or in the second deviated position, the outlet opening communicates only with one of the two conveying chambers, involving the entire development of the closure door.

[0012] If storage of the first and of the second type of waste is expected in roughly equal quantities, before performing the normal work shift, the orientable portion of the dividing baffle is set in the coplanar position.

[0013] Vice versa, if one type of waste is expected to be stored in larger quantity than the other, the orientable portion is set in the first or in the second deviated position.

[0014] The apparatuses for the differentiated collection of waste described above present a very reduced operating flexibility, since the choice of position of the orientable portion is limited exclusively to three different volume distributions of the holding container, corresponding for instance to percentage ratios of 50/50, 60/40 and 40/60 between the two conveying chambers, without any possibility of obtaining intermediate distributions among the three values designed by the manufacturer. It is also necessary to forecast the quantity of different waste to be stored during the work shift in order to set the orientable portion of the dividing baffle beforehand according to the correct position.

[0015] It should also be considered that the quantity of waste accumulated in the various collection points can change within a very short time span and, therefore, it is not easy to predict exactly which type of waste may be collected in greater quantity.

[0016] Another problem of considerable importance noted by the Applicant is linked to the opening of the off-loading door, whose upper portion can be opened independently from the lower one, whilst the latter can only be opened together with the upper one. Consequently, when the orientable portion of the baffle is in the coplanar position, the operator is forced to off-load first the upper conveying chamber even when he is nearer to a collecting post for the waste contained in the lower conveying chamber. When the orientable portion of the dividing baffle is in the first or in the second deviated position, the operator is forced to empty first the conveying chamber made more capacious by virtue of the position presented by the orientable portion itself.

[0017] In essence it is never possible to choose which holding chamber is to be emptied first, since the position of the orientable portion of the dividing baffle determines the order of emptying.

[0018] Document US 5,584,642 shows an apparatus for storing rubbish comprising a container divided in an upper and a lower conveying chambers by an orientable portion. An actuator is operatively engaged to the orientable portion for thrusting this latter towards the lower conveying chamber. When the degree of filling of the lower conveying chamber reaches a predetermined value, the thrust action exerted by the refuse become

greater than the thrust force exerted by the orientable portion, which is consequently pushed towards the upper conveying chamber, thus increasing the volume of the lower conveying chamber. Moreover the relative volumes of the upper and lower chambers can "self adjust" in response to the actual volumes of refuse placed into the vehicle.

[0019] Document WO 97/45292 shows an apparatus exhibiting a lower conveying chamber and at least an upper conveying chamber divided each other by a dividing baffle designed to be lowered for facilitating the expulsion of waste from the upper chamber, once the lower chamber has been already emptied. The dividing baffle is also positionable upward and downward between two extreme positions for increasing the volume of one or the other conveying chamber. The positioning operation of the baffle requires to add or remove some heavy components, and may be achieved only when the vehicle stands still in a garage.

[0020] Document US 5,316,430 shows an apparatus comprising a telescopic L-shaped dividing baffle which is movable towards one or the other conveying chamber to increase, when necessary, the volume of the one or the other conveying chamber. The volume adjustment is achieved by an operator which must visually control the degree of fullness of the conveying chambers.

[0021] The object of the present invention is essentially to solve the problems of the prior art, proposing a method and an apparatus for storing rubbish in a motor vehicle intended for differentiated collection, with which it is possible to manage in a timely fashion the volumes of the conveying chambers according to the different quantities of waste loaded, also enabling to choose according to the needs at hand the sequence whereby the conveying chambers are emptied.

[0022] This aim and others besides which shall become more readily apparent in the course of the present description, are essentially attained by a method for storing rubbish in a motor vehicle intended for differentiated collection of the same comprising the characteristics expressed in the characterising part of claim 1.

[0023] According to the present invention, the aforesaid method is embodied with a rubbish storage apparatus mounted on a motor vehicle for the differentiated collection of the same, comprising the characteristics expressed in the characterising part of claim 9.

[0024] Additional features and advantages shall become more readily available from the detailed description of a preferred, but not exclusive, embodiment of a method and of an apparatus for storing rubbish on a motor vehicle intended for differentiated collection of the same, according to the present invention. This description shall be made hereafter with reference to the accompanying drawings, provided purely by way of non limiting example, wherein:

- Figure 1 shows a motor vehicle intended for differentiated collection of rubbish with a storage appa-

ratus according to the invention shown in longitudinal section;

- Figure 2 highlights in section the storing apparatus with a first outlet door open to allow emptying a first conveying chamber;
- Figure 3 highlights in section the storing apparatus with a second closure door open for the expulsion of the rubbish contained in the second conveying chamber.

[0025] With reference to the aforesaid figures, the number 1 indicates in its entirety an apparatus for storing rubbish on a motor vehicle intended for differentiated collection of the same, operating according to a rubbish storing method in accordance with the present invention.

[0026] The storing apparatus 1 comprises at least one holding container 2 presenting internally at least one dividing baffle 3 which delimits, in the container itself, a first conveying chamber 4, for instance positioned higher, and a second conveying chamber 5 positioned lower.

[0027] As can be seen from the figures, the holding container 2 is positioned at the rear of a motor vehicle 6 intended for differentiated rubbish collection, equipped with a loading hopper 7 interposed between the container itself and a driver's cab 6a of the motor vehicle 6. The loading hopper 7 is set to receive the rubbish coming out of a bin (not shown in the figures) which, by means of a gripping and upsetting device 8 known in itself, is picked up from the ground and upset above the hopper itself causing the rubbish to fall thereinto.

[0028] In the loading hopper 7 are present first and second transfer means, only partially shown in figures 2 and 3 because they can be constructed in a known way, comprising for instance respective thrusters 9a, 9b which selectively transfer the first and the second waste respectively into the first and into the second conveying chamber 4, 5, through a first and a second inlet opening 10, 11, associated to a front wall 12 of the holding container 2. The first and the second waste are thus continually inserted in the respective conveying chambers 4, 5 until suitable sensor means detect and indicate that a pre-set degree of filling has been reached in one and/or in the other conveying chamber 4, 5.

[0029] The sensor means are not described in detail or shown since they can be made in any convenient manner by the technician versed in the art. For instance, such sensor means may comprise pressure transducers operating in a way known in itself on the hydraulic circuits actuating the transfer means 9a, 9b. The transducers are able to emit a signal when, once the pre-set degree of filling of one of the conveying chambers 4, 5 is reached, there is an increase in the pressure of the hydraulic circuit of the respective transfer means 9a, 9b due to the greater thrust which must be imparted to transfer and compact the waste in the chamber itself.

[0030] According to the present invention, the apparatus 1 further comprises driving means 13 operating on

the dividing baffle 3 to adapt selectively the volume of the conveying chambers 4, 5 to the quantity of the first and of the second waste stored.

[0031] More in particular, the driving means 13 preferably operate on an orientable portion 14 of the dividing baffle 3, positioned in the lower part of the holding container 2 and hinged according to a horizontal axis to a fixed portion 15 of the dividing baffle itself.

[0032] In the embodiment shown in the drawings, the driving means 13 comprise one or more hydraulic actuators 16 engaged externally to the holding container 2 and operating on lateral pins 17 projecting from the orientable portion 14 through respective arched slots 18 obtained on the walls of the holding container 2. The arched slots 18 present a curvilinear development concentric to the hinge axis of the orientable portion 14 of the dividing baffle 3.

[0033] The driving means 13 may be set to position the orientable portion 14 of the dividing baffle 3 in a plurality of intermediate positions "C" comprised between a first and a second limit position "A", "B", as can be seen in Figure 1. In the first limit position "A", the orientable portion 14 is inclined upward with respect to the fixed portion 15, minimising the capacity of the first conveying chamber 4. Conversely, when it is situated in the second limit position "B", the orientable portion 14 is inclined downward with respect to the fixed portion 15, thereby minimising the volume of the second conveying chamber 5.

[0034] Between the first and second limit position "A", "B" and the various intermediate positions "C", an emptying position "D" (visible in Figures 2 and 3) is further defined, wherein the orientable portion 14 is coplanar with respect to the fixed portion 15.

[0035] Moreover, support means 30 are preferably provided associated to the orientable portion 14 of the dividing baffle 3 and operatively connected to the holding container 2 to support the orientable portion itself thereby compensating at least partially for its weight.

[0036] Such support means 30 can for instance comprise torsion bars or other elastic organs, such as springs 31 engaged externally to the holding container 2 and operating on the lateral pins 17 or on auxiliary lateral pins 32 of the orientable portion 14. Such auxiliary pins are preferably guided along respective curved slots 33 obtained in proximity to the hinge axis of the orientable portion 14, for instance at a distance not exceeding 1/10 of the distance between the hinge axis itself and a terminal edge 24 of the orientable portion 14. The springs 31 are thus subjected to relatively small deformations as a result of the excursion performed by the orientable portion 14. It is thereby possible to ensure that the elastic reaction exerted by the springs 31 maintains a value suitable to balance the weight of the orientable portion 14, without undergoing subsequent changes as a result of the movements made by the latter.

[0037] Opposite to the first and the second inlet open-

ing 10, 11, on the holding container 2 are present a first and a second outlet opening 19, 20 respectively provided with a first and a second closure door 21, 22.

[0038] The first and the second outlet opening 19, 20 are preferably delimited from each other, in correspondence with a common delimiting edge, by means at least of one transverse bar 23 engaged to the rear end of the holding container 2, in coincidence with the terminal edge 24 of the orientable portion 14 when the container is in the emptying condition "D".

[0039] Both the first and the second closure door 21, 22 extend consecutively according to an arched profile concentric to the hinge axis of the orientable portion 14 of the dividing baffle 3. In the embodiment shown, the first door 21 is arched according to the description above in its lower semi-part 21a, whilst an upper semi-part 21b thereof, hinged on the upper part of the holding container 2 presents a square right angle profile which allows for greater exploitation of the volume of the holding container itself.

[0040] The second door 22 is entirely shaped according to an arched profile, and it is oscillatorily hinged below the transverse bar 23.

[0041] The arched profile of the closure doors 21, 22 ensures that the terminal edge 24 of the orientable portion 14 essentially remains in contact on the arched surfaces of the doors themselves, guaranteeing an effective mutual separation of the first and of the second waste in any operative position assumed by the orientable portion itself. It is possible to use closure doors 21, 22 with a profile differing from the description above, setting the terminal edge 24 on a bulkhead movable telescopically with respect to the orientable portion 14 and positioned as an extension thereto.

[0042] First and second opening means 25, 26 comprising for instance first and second hydraulic opening actuators 27, 28, are associated respectively to the first and to the second closure door 21, 22 to open them independently from each other.

[0043] In accordance with the storing method according to the invention, the operation of the subject apparatus 1 is the following.

[0044] During the performance of the usual work shift, the first and the second waste emptied from the bins are progressively inserted respectively into the first and into the second conveying chamber 4, 5.

[0045] In a way known in itself, the first and the second transfer means 9a, 9b are able to transfer the first and the second waste into the respective conveying chambers 4, 5 compacting them to an increasing extent, thereby progressively increasing the degree of filling of the chambers themselves even after their entire volume is occupied.

[0046] The progressive compacting of the waste in the first or, respectively, in the second conveying chamber 4, 5 determines a progressive increase of the thrust which the transfer means 9a, 9b need to impart to compact additional waste in the chamber itself, and a corre-

sponding pressure increase in the hydraulic circuit associated to the transfer means themselves.

[0047] When the pressure increase in the hydraulic circuit associated respectively to the first and to the second transfer means 9a, 9b exceeds a pre-determined threshold, the aforesaid sensor means detect and indicate that the pre-set degree of filling has been reached in the corresponding conveying chamber 4, 5.

[0048] The indication of the sensor means can be sent directly to the driver of the motor vehicle 6, or to an electronic control unit, thereby determining, respectively upon command from the driver or from the control unit, the possible intervention of the driving means 13 associated to the orientable portion 14 of the dividing baffle 3.

[0049] Upon command of the driving actuators 16, the orientable portion 14 shall be moved according to a pre-set motion step or in any other way able to increase to a pre-determined extent the capacity of the conveying chamber 4, 5 which has reached the pre-set degree of filling.

[0050] Assuming for instance that the first conveying chamber 4 has been filled, the orientable portion 14, initially placed in the emptying position "D", shall be moved downward to the next intermediate position.

[0051] The displacement of the orientable portion 14 towards the second conveying chamber 5 may be repeated, in the course of the work shift, every time the attainment of the pre-set degree of filling is detected in the first conveying chamber 4 in the way described above.

[0052] Alternatively to what has been described above, it is also possible for the driving means 13 to remain essentially inactive during waste collection, and for the orientable portion 14, balanced by the compensation means 30, to be left free to move spontaneously inside the holding chamber 2 to adapt the volume of the conveying chambers 4, 5 to the quantities of first and second waste inserted.

[0053] More specifically the orientable portion 14, adequately balanced by the compensation means 30 that cancel its weight, is subjected to the thrust imparted on its opposite sides by the first and by the second waste compacted respectively in the first and in the second conveying chamber 4, 5.

[0054] Under this circumstance, as soon as the degree of filling in one of the conveying chambers 4, 5 and thus the compaction and the thrust imparted by the respective waste, exceeds the degree of filling of the other chamber, the orientable portion 14 spontaneously moves under the effect of the thrust imparted by the waste present in the fuller chamber, increasing its volume until the thrusts imparted respectively by the first and by the second waste return to being essentially equal.

[0055] When the aforementioned sensor means detect that both the first and the second conveying chamber 4, 5 have reached the pre-set level of filling, it is necessary to empty the waste from the holding container 2

in correspondence with the locations destined to treat and/or recycle the waste itself.

[0056] To this end, the orientable portion 14 of the dividing baffle 3 is brought, upon command of the driving actuators 16, to the emptying position "D", with its own terminal edge 24 coinciding with the common delimitation edge of the outlet openings 19, 20, as shown in Figures 2 and 3.

[0057] Under this circumstance, the orientable portion 14 determines a further compaction of the waste contained in the first conveying chamber 4 or anyway in the chamber whose internal volume had previously been increased during the execution of the work shift.

[0058] The use of the orientable portion 14 as a compaction means is also made possible by the fact that the degree of compaction conferred to the waste by the transfer means decreases progressively starting from the front wall 12 of the holding container 2 towards its rear part.

[0059] The possibility is not to be excluded of providing, in association with the orientable portion 14, additional compacting means to compact the waste contained in one or the other conveying chamber 4, 5 in order to allow and/or facilitate the movement of the orientable portion itself towards the emptying position "D".

[0060] After the orientable portion 14 of the dividing baffle 3 has been placed in the emptying position "D", the operator may advantageously decide according to his needs whether to empty one or the other conveying chamber 4, 5 first.

[0061] The motor vehicle is driven to the location set to receive the waste which the operator has decided to off-load first, whereupon the closure door 21, 22 of the conveying chamber 4, 5 containing the waste to be expelled is opened. Subsequently this waste is expelled through the respective outlet opening 19, 20, for instance with the aid of an expulsion 29a, 29b known in itself, associated to the respective transfer means 9a, 9b and movable together thereto along the holding container 2.

[0062] The closure door 21, 22 is subsequently closed again, whereupon the motor vehicle 6 moves to the place destined to receive the waste still present within the holding container 2. Once this location is reached, the closure door 21, 22, not involved in the first opening phase described above and corresponding to the still full conveying chamber 4, 5, is opened. A second expulsion phase is then performed wherein the waste in the conveying chamber 4, 5 associated to the closure door 21, 22 opened in the first opening phase, is off-loaded from the holding container 2.

[0063] The apparatus 1 according to the present invention may be constructed with a single closure door associated to a single outlet opening.

[0064] In this case, between the first and the second limit position "A", "B", or to coincide thereto, a first and a second emptying position are defined wherein the terminal edge 24 of the orientable portion 14 collimates re-

spectively with a first and a second edge of the outlet opening itself respectively positioned, for instance, in the lower part and in the upper part of the holding container 2.

[0065] If for instance the operator wants initially to empty the first conveying chamber 4 positioned in the upper part of the collection container 2, the orientable portion 14 is set in the first emptying position, compacting the second waste contained in the second conveying chamber located at the bottom. Subsequently the closure door is opened and the first waste is expelled with the aid of the respective expulsion bulkhead 29a.

[0066] After the first conveying chamber 4 is emptied, the motor vehicle 6 is driven to the location set to receive the second waste, wherein the position of the orientable portion 14 of the dividing baffle 3 is switched from the first to the second emptying position. Subsequently, the closure door is opened again and the second waste is expelled from the collection container 2 through the outlet opening by means of the respective expulsion bulkhead 29b.

[0067] If the operator decides initially to empty the second conveying chamber 5, the emptying cycle of the conveying chambers just described is performed inversely.

[0068] The present invention thereby attains the proposed aims.

[0069] The invention has the advantages of allowing to empty first indifferently one or the other conveying chamber 4, 5, depending on needs.

[0070] The apparatus according to the present invention further allows to adapt in a timely manner the internal volume distribution of the collection container 2 according to the quantities of one or the other waste as the waste itself is collected.

[0071] A considerable increase in the operative flexibility of the motor vehicle intended for rubbish collection is thereby attained. Although the present description is referred to the differentiated collection of two types of waste, nothing precludes the possibility of adapting the apparatus to operate on three or more types of waste, setting a suitable number of conveying chambers, of dividing baffles and of outlet openings.

[0072] Instead of the orientable portion 14, the baffle 3 may be terminally hinged in proximity to the front wall 12 in such a way that the entire dividing baffle, possibly upon the action of the driving means 13, is involved in the displacements aimed at the volume adaptation of the conveying chambers 4, 5

Claims

1. Method for storing rubbish on a motor vehicle intended for differentiated collection of the same, comprising the phases of:

- inserting at least a first and a second waste re-

spectively in a first and a second conveying chamber (4, 5) of a holding container (2) fitted on a motor vehicle (6), said conveying chambers (4, 5) being delimited by at least one dividing baffle (3); - moving at least one orientable portion (14) of the dividing baffle (3) towards the first conveying chamber (4) by effect of a thrusting action imparted by the waste inserted into the second conveying chamber (5) to increase selectively the volume of the second conveying chamber (5) wherein a degree of filling has been reached that is greater than the degree of filling reached in the other conveying chamber, and further comprising:

- a first opening phase wherein a second closure door (22) communicating with the second conveying chamber (5) through a second outlet opening (20) of the holding container (2) is selectively opened;
- a first expulsion phase wherein the waste contained in the conveying chamber (5) associated to the open closure door (22) is off-loaded from the holding container (2);
- a second opening phase wherein a first closure door (21) communicating with the first conveying chamber (4) through a first outlet opening (19) of the holding container (2) and not involved in the first opening phase is opened;
- a second expulsion phase wherein the waste in the conveying chamber (4) associated to the closure door (21) opened in the second opening phase is off-loaded from the holding container (2)

characterised in that before said first opening phase the phase of positioning the orientable portion (14) of the dividing baffle (3) in an emptying position ("D") wherein a terminal edge (24) of the dividing baffle (3) collimates with a common delimiting edge of the first and of a second outlet opening (19,20) is achieved.

2. Method according to claim 1, wherein the movement of the movable portion (14) of the dividing baffle (3) is actuated by effect of a thrusting action imparted by the waste inserted into the conveying chamber (4, 5) presenting the greater degree of filling.

3. Method according to claim 1, further comprising the phase of detecting and indicating whether a pre-determined degree of filling has been reached selectively in one or in the other conveying chamber (4,5), the movement of said movable portion (14) being actuated in response to said indication.

4. Method according to claim 3, **characterised in that** the detection and indication phase and said movement phase of the orientable portion (14) of the dividing baffle (3) are cyclically repeated until the detection of the pre-determined degree of filling in both conveying chambers (4,5).
5. Method according to claim 4, **characterised in that** the phase wherein the orientable portion (14) of the dividing baffle (3) is moved to the emptying position ("D") is performed simultaneously with an action of compacting the waste contained in one of the conveying chambers (4,5).
6. Method according to claim 4, **characterised in that** said phase of inserting the waste into said first and second conveying chamber (4, 5) occurs through at least one inlet opening (10,11) obtained on the holding container on the side opposite to said at least first outlet opening (19,20).
7. Method according to claim 4, **characterised in that** said phase wherein said orientable portion (14) is positioned occurs selectively in a first or a second emptying position wherein a terminal edge (24) of the dividing baffle (3) collimates respectively with a first or a second edge of the first outlet opening to place selectively the first or the second conveying chamber (4, 5) in communication with the first opening.
8. Method according to claim 7, further comprising the following phases:
- opening at least one off-loading door (21, 22) associated to said at least first outlet opening (19);
 - expelling through the first outlet opening (19) the waste contained in the conveying chamber (4,5) communicating with the outlet opening itself;
 - switching the position of the orientable portion (14) of the dividing baffle (3) between the first and the second emptying position;
 - expelling through the outlet opening (19) the waste contained in the conveying chamber (4,5) communicating with the outlet opening itself.
9. Apparatus for storing rubbish on a motor vehicle intended for differentiated collection of the same, comprising:
- at least one holding container (2) presenting at least a first and a second conveying chamber (4,5) delimited by at least one dividing baffle (3);
 - first transfer means (9a) to insert a first waste into the first conveying chamber (4);
 - second transfer means (9b) to insert a second waste into the second conveying chamber (5);
- said dividing baffle (3) comprising at least one orientable portion (14) movable within the holding container (2) to increase selectively the volume of the second conveying chamber (4,5) wherein a degree of filling has been reached that is greater than the degree of filling reached in the other conveying chamber, further comprising driving means (13) operating on the dividing baffle (3) to position said orientable portion (14) in at least one emptying position ("D") wherein a terminal edge (24) of the dividing baffle (3) collimates with an edge of at least one outlet opening (19,20) of the holding container (2), **characterized in that** in the emptying position ("D") the terminal edge (24) of the dividing baffle (3) collimates with a common edge between a first and a second outlet opening (19,20) obtained on the holding container (2), provided respectively with at least a first and at least a second closure door (21,22) and communicating respectively with the first and the second conveying chamber (4,5), wherein it further comprises at least one support bar (23) engaged to the rear end of the holding container (2) and defining the common edge between the first and the second outlet opening (19,20), said second door (22) being oscillatorily engaged to said support bar (23).
10. Apparatus according to claim 9, wherein said orientable portion (14) is movable by effect of thrusting actions imparted respectively by the first and second waste inserted into the first and second conveying chamber (4,5).
11. Apparatus according to claim 9, wherein said driving means (13) are set to position the orientable portion (14) selectively in a first or a second emptying position wherein a terminal edge (24) of the dividing baffle (3) collimates respectively with a first or a second edge of the first outlet opening to place selectively the first or the second conveying chamber (4,5) in communication with the first opening itself.
12. Apparatus according to claim 9, further comprising sensor means set to detect and indicate the reaching of a pre-set degree of filling selectively in each of said conveying chambers (4,5), said driving means (13) being able to be activated in response to indications emitted by the sensor means to determine the movement of the orientable portion (14) inside the holding container (2).
13. Apparatus according to claim 12, **characterised in that** said driving means (13) are set to place the orientable portion (14) of the dividing baffle (3) in a plurality of intermediate positions ("C") comprised

between a first and a second limit position ("A", "B").

14. Apparatus according to claim 9, **characterised in that** said first and second closure door (21,22) are provided respectively with first and second opening means (25,26) which can be actuated independently from each other to allow the selective emptying of the first and of the second conveying chamber (4,5).
15. Apparatus according to claim 9, **characterised in that** at least one inlet opening (10,11) is obtained on the holding container opposite to the outlet opening (19,20), said first and second waste being inserted into the respective conveying chambers (4,5) through said at least one inlet opening (10,11).
16. Apparatus according to claim 9, further comprising compacting means operatively associated to the orientable portion (14) of the dividing baffle (3) to compact the waste contained in one or in the other conveying chamber (4,5) simultaneously with the positioning of the orientable portion itself in the emptying position.
17. Apparatus according to claim 16, **characterised in that** said compacting means comprise the same orientable portion (14) of the dividing baffle (3), the orientable portion being set to impart a thrusting action on the waste positioned in the conveying chambers (4,5).
18. Apparatus according to claim 9, **characterised in that** it further comprises compensation means (30) operatively engaged to the holding container (2) and connected to said at least one orientable portion (14) of the dividing baffle (3) to support it compensating for its weight.

Patentansprüche

1. Verfahren zum Aufbewahren von Müll an einem Müllsammelfahrzeug zum getrennten Sammeln des Mülls, umfassend die folgenden Schritte:
- Einbringen eines ersten und eines zweiten Mülls in eine erste bzw. zweite Förderkammer (4, 5) eines an einem Fahrzeug (6) angebrachten Sammelbehälters (2), wobei die Förderkammern (4, 5) durch mindestens eine Trennwand (3) begrenzt sind;
 - Verstellen mindestens eines schwenkbaren Abschnittes (14) der Trennwand (3) in Richtung der ersten Förderkammer (4) durch Einwirken eines durch den in der zweiten Förderkammer (5) eingebrachten Müll ausgeübten Schubes, um wahlweise das Volumen der zweiten För-

derkammer (5) zu erhöhen, in der ein Füllgrad erreicht wurde, der größer ist als der in der anderen Förderkammer, und umfassend überdies:

- einen ersten Öffnungsschritt, bei dem wahlweise eine zweite Schließtür (22) geöffnet wird, die mit der zweiten Förderkammer (5) über einer zweiten Austrittsöffnung (20) des Sammelbehälters (2) in Verbindung steht;
- einen ersten Ausstoßschritt, bei dem der in der, der geöffneten Schließtür (22) zugeordneten Förderkammer (5) enthaltene Müll (5) aus dem Sammelbehälter (2) ausgeleert wird;
- einen zweiten Öffnungsschritt, bei dem eine erste Schließtür ((21) geöffnet wird, die mit der ersten Förderkammer (4) über eine erste Austrittsöffnung (19) des Sammelbehälters (2) in Verbindung steht und beim ersten Öffnungsschritt nicht beansprucht wird;
- einen zweiten Ausstoßschritt, bei dem der Müll in der Förderkammer (4), die der beim ersten Öffnungsschritt geöffneten Schließtür (21) zugeordnet ist, aus dem Sammelbehälter (2) entleert wird,

dadurch gekennzeichnet, dass vor dem ersten Öffnungsschritt der Schritt des Positionierens des schwenkbaren Abschnittes (14) der Trennwand (3) in eine Entleerungsstellung ("D") durchgeführt wird, in der eine Endkante (24) der Trennwand (3) mit einer gemeinsamen Begrenzungskante der ersten und einer zweiten Austrittsöffnung (19, 20) ausgerichtet ist.

2. Verfahren nach Anspruch 1, bei dem das Verstellen des beweglichen Abschnittes (14) der Trennwand (3) durch eine Schubwirkung durchgeführt wird, die durch den Müll ausgeübt wird, der in die den größeren Füllgrad aufweisenden Förderkammer (4, 5) eingebracht wurde.
3. Verfahren nach Anspruch 1, umfassend überdies den Schritt des Erfassens und der Angabe der Erreichung eines vorgegebenen Füllgrades wahlweise in der einen oder der anderen Förderkammer (4, 5), wobei das Verstellen des beweglichen Abschnittes (14) auf Ansprechen dieser Angabe durchgeführt wird.
4. Verfahren nach Anspruch 3, **dadurch gekennzeichnet, dass** der Erfassungs- und Angabeschritt und der Verstellschritt des schwenkbaren Abschnittes (14) der Trennwand (3) taktweise wiederholt werden bis der vorgegebene Füllgrad in beiden Förderkammern (4, 5) erfasst wird.
5. Verfahren nach Anspruch 4, **dadurch gekennzeichnet, dass** der Positionierschritt des schwenk-

baren Abschnittes (14) der Trennwand (3) in der Entleerstellung ("D") in Begleitung mit einer Verdichtungswirkung des in einer der Förderkammern (4,5) enthaltenen Mülls durchgeführt wird.

6. Verfahren nach Anspruch 4, **dadurch gekennzeichnet, dass** der Einbringsschritt des Mülls in die erste und zweite Förderkammer (4, 5) über mindestens eine Eintrittsöffnung (10, 11) erfolgt, die am Sammelbehälter auf der zur mindestens ersten Austrittsöffnung (19, 29) abgewandten Seite erfolgt.

7. Verfahren nach Anspruch 4, **dadurch gekennzeichnet, dass** der Positionierschritt des schwenkbaren Abschnittes (14) wahlweise in einer ersten oder einer zweiten Entleerstellung erfolgt, in der eine Endkante (24) der Trennwand (3) jeweils mit einer ersten oder zweiten Kante der ersten Austrittsöffnung ausgerichtet ist, um die erste oder die zweite Förderkammer (4, 5) in Verbindung mit der ersten Öffnung selbst zu bringen.

8. Verfahren nach Anspruch 7, umfassend überdies die folgenden Schritte:

- Öffnen mindestens einer Entleerungstür (21, 22), die mindestens einer ersten Austrittsöffnung (19) zugeordnet ist;
- Ausstoßen über die erste Austrittsöffnung (19) des in der Förderkammer (4, 5) enthaltenen Mülls, die mit der Austrittsöffnung selbst in Verbindung steht;
- Umschalten der Positionierung des schwenkbaren Abschnittes (14) der Trennwand (3) zwischen der ersten und der zweiten Entleerstellung;
- Ausstoßen über die Austrittsöffnung (19) des in der Förderkammer (4, 5) enthaltenen Mülls, die mit der Austrittsöffnung selbst in Verbindung steht.

9. Einrichtung zum Aufbewahren von Müll an einem Müllsammelfahrzeug zum getrennten Sammeln des Mülls, umfassend:

- mindestens einen Sammelbehälter (2), der mindestens eine erste und eine zweite Förderkammer (4, 5) aufweist, die durch mindestens eine Trennwand (3) abgegrenzt sind;
- erste Übergabemittel (9a) um einen ersten Müll in die erste Förderkammer (4) einzubringen;
- zweite Übergabemittel (9b) um einen zweiten Müll in die zweite Förderkammer (5) einzubringen;
- wobei die Trennwand (3) mindestens einen schwenkbaren Abschnitt (14) umfasst, der innerhalb des Sammelbehälters (2e) verstellbar ist, um wahlweise das Volumen der zweiten

Förderkammer (4, 5) zu erhöhen, in der ein größerer Füllgrad erreicht wurde, als der Füllgrad, der in der anderen Förderkammer erreicht wurde, umfassend überdies Verstellmittel (13), die auf die Trennwand (3) wirken um den schwenkbaren Abschnitt (14) in mindestens einer Entleerstellung ("D") zu positionieren, in der eine Endkante (24) der Trennwand (3) mit einer Kante mindestens einer Austrittsöffnung (19, 20) des Sammelbehälters (2) ausgerichtet ist,

dadurch gekennzeichnet, dass in der ersten Entleerstellung ("D") die Endkante (24) der Trennwand (3) mit einer gemeinsamen Kante zwischen einer ersten und einer zweiten Austrittsöffnung (19, 20) ausgerichtet ist, die am Sammelbehälter (2) angenommen, mit jeweils mindestens einer ersten und mindestens einer zweiten Schließtür (21, 22) versehen sind und jeweils mit der ersten und der zweiten Förderkammer (4,5) in Verbindung stehen, wobei die Einrichtung überdies mindestens eine Tragstange (23) umfasst, die am hinteren Ende des Sammelbehälters (2) angreift und die gemeinsame Kante zwischen der ersten und der zweiten Austrittsöffnung (19, 20) festlegt, wobei die zweite Schließtür (22) schwenkbar an der Tragstange (23) angreift.

10. Einrichtung nach Anspruch 9, bei der der schwenkbare Abschnitt (14) durch Einwirken eines Schubs verstellbar ist, der jeweils durch den ersten und den zweiten Müll ausgeübt wird, die in die erste und zweite Förderkammer eingebracht wurden.

11. Einrichtung nach Anspruch 9, bei der die Verstellmittel (13) bereitgestellt sind, um den schwenkbaren Abschnitt (14) wahlweise in einer ersten oder zweiten Entleerstellung zu positionieren, in der eine Endkante (24) der Trennwand (3) jeweils mit einer ersten oder einer zweiten Entleerstellung ausgerichtet ist, in der eine Endkante (24) der Trennwand (3) jeweils mit einer ersten oder einer zweiten Kante der ersten Austrittsöffnung ausgerichtet ist, um die erste oder die zweite Förderkammer (4, 5) mit der ersten Öffnung selbst wahlweise in Verbindung zu setzen.

12. Einrichtung nach Anspruch 9, umfassend überdies Fühlermittel, die bereitgestellt sind, das Erreichen eines vorgegebenen Füllgrades wahlweise in einer jeden der Förderkammern (4, 5) zu erfassen und anzugeben, wobei die Verstellmittel (13) auf Ansprechen von Angaben aktivierbar sind, die von den Fühlermitteln ausgegeben werden, um die Verstellung des schwenkbaren Abschnittes (14) innerhalb des Sammelbehälters (2) zu bewirken.

13. Einrichtung nach Anspruch 9, **dadurch gekenn-**

zeichnet, dass die Verstellmittel (13) bereitgestellt sind, den schwenkbaren Abschnitt (14) der Trennwand (3) in einer Vielzahl von Zwischenstellungen ("C") zu positionieren, die zwischen einer ersten und einer zweiten Grenzstellung ("A", "B") liegen. 5

14. Einrichtung nach Anspruch 9, **dadurch gekennzeichnet, dass** die erste und die zweite Schließstür (21, 22) mit jeweils ersten und zweiten Öffnungsmitteln (25, 26) versehen sind, die unabhängig von einander betätigbar sind, um die wahlweise Entleerung der ersten und der zweiten Förderkammer (4, 5) zu erlauben. 10
15. Einrichtung nach Anspruch 9, **dadurch gekennzeichnet, dass** mindestens eine Eintrittsöffnung (10, 11) am Sammelbehälter auf der zur Austrittsöffnung abgewandten Seite ausgenommen ist. 15
16. Einrichtung nach Anspruch 9, umfassend überdies Verdichtungsmittel, die wirksam dem schwenkbaren Abschnitt (14) der Trennwand (3) zugeordnet sind, um den in der einen oder der anderen Förderkammer enthaltenen Müll (4, 5) in Begleitung mit der Positionierung des schwenkbaren Abschnittes selbst in der Entleerstellung zu kompaktieren. 20 25
17. Einrichtung nach Anspruch 16, **dadurch gekennzeichnet, dass** die Verdichtungsmittel denselben schwenkbaren Abschnitt (14) der Trennwand (3) umfassen, wobei dieser Abschnitt bereitgestellt ist, einen Schub auf den in den Förderkammern (4, 5) angeordneten Müll auszuüben. 30
18. Einrichtung nach Anspruch 9, **dadurch gekennzeichnet, dass** sie überdies Ausgleichmittel (30) umfasst, die am Sammelbehälter (2) wirksam in Eingriff stehen und mit mindestens dem einen schwenkbaren Abschnitt (14) der Trennwand (3) verbunden sind, um ihn abzustützen, indem sein Gewicht ausgeglichen wird. 35 40

Revendications

1. Procédé de stockage de déchets dans un véhicule destiné à collecter séparément des déchets, comprenant les étapes suivantes: 45
- insérer respectivement au moins des premières et des deuxièmes ordures dans un premier et un deuxième compartiments d'acheminement (4, 5) d'un récipient de collecte (2) disposé sur un véhicule (6), lesdits compartiments d'acheminement (4, 5) étant délimités par au moins une cloison de séparation (3); 50 55
 - déplacer au moins une portion orientable (14) de la cloison de séparation vers le premier com-

partiment d'acheminement (4) par effet d'une action de poussée imprimée par les ordures insérées dans le deuxième compartiment d'acheminement (5) pour augmenter sélectivement le volume du deuxième compartiment d'acheminement (5) dans lequel on a atteint un degré de remplissage supérieur au degré de remplissage atteint dans l'autre compartiment d'acheminement, et comprenant en outre:

- une première étape d'ouverture dans laquelle il y a l'ouverture sélective d'une deuxième porte de fermeture (22) en communication avec le deuxième compartiment d'acheminement (5) à travers une deuxième ouverture de sortie (20) du récipient de collecte (2);
- une première étape d'expulsion dans laquelle les ordures contenues dans le compartiment d'acheminement (5) associé à la porte de fermeture (22) ouverte sont déchargées du récipient de collecte (2);
- une deuxième étape d'ouverture dans laquelle il y a l'ouverture d'une première porte de fermeture (21) en communication avec le premier compartiment d'acheminement (4) à travers une première ouverture de sortie (19) du récipient de collecte (2) et non impliquée dans la première étape d'ouverture;
- une deuxième étape d'expulsion dans laquelle les ordures dans le compartiment d'acheminement (4) associé à la porte de fermeture (21) ouverte dans la deuxième étape d'ouverture sont déchargées du récipient de collecte (2);

caractérisé en ce que, avant ladite première étape d'ouverture, on effectue l'étape de mise en place de la portion orientable (14) de la cloison de séparation (3) à une position de vidage ("D") à laquelle un bord terminal (24) de la cloison de séparation (3) correspond exactement à un bord commun de délimitation de la première et d'une deuxième ouverture de sortie (19, 20).

2. Procédé selon la revendication 1, dans lequel le mouvement de la portion mobile (14) de la cloison de séparation (3) est réalisé par effet d'une action de poussée imprimée par les ordures insérées dans le compartiment d'acheminement (4, 5) présentant le plus haut degré de remplissage.

3. Procédé selon la revendication 1, comprenant en outre l'étape de détecter et indiquer si on a atteint un degré prédéterminé de remplissage sélectivement dans l'un ou l'autre des compartiments d'acheminement (4, 5), le mouvement de ladite portion mobile (4) étant effectué en réponse à ladite indication.

4. Procédé selon la revendication 3, **caractérisé en**

- ce que** l'étape de détection et d'indication et ladite étape de mouvement de la portion orientable (14) de la cloison de séparation (3) sont répétées de manière cyclique jusqu'à la détection d'un degré prédéterminé de remplissage dans les deux chambres d'acheminement (4, 5).
- 5
5. Procédé selon la revendication 4, **caractérisé en ce que** l'étape dans laquelle la portion orientable (14) de la cloison de séparation (3) est mue à la position de vidage ("D") est effectuée simultanément à une action de compactage des ordures contenues dans l'un des compartiments d'acheminement (4, 5).
- 10
6. Procédé selon la revendication 4, **caractérisé en ce que** ladite étape d'insérer les ordures dans lesdits premier et deuxième compartiments d'acheminement (4, 5) se produit à travers au moins une ouverture d'entrée (10, 11) obtenue sur le récipient de collecte du côté opposé par rapport à ladite au moins première ouverture de sortie (19, 20).
- 20
7. Procédé selon la revendication 4, **caractérisé en ce que** ladite étape dans laquelle ladite portion orientable (14) est mise en place se produit sélectivement à une première ou à une deuxième positions de vidage où un bord terminal (24) de la cloison de séparation (3) correspond exactement à un premier ou respectivement à un deuxième bord de la première ouverture de sortie pour mettre sélectivement le premier ou le deuxième compartiment d'acheminement (4, 5) en communication avec la première ouverture.
- 25
- 30
- 35
8. Procédé selon la revendication 7, comprenant en outre les étapes suivantes:
- ouvrir au moins une porte de déchargement (21, 22) associée à ladite au moins première ouverture de sortie (19);
 - expulser à travers la première ouverture de sortie (19) les ordures contenues dans le compartiment d'acheminement (4, 5) en communication avec l'ouverture de sortie elle-même;
 - changer la position de la portion orientable (14) de la cloison de séparation (3) entre les première et deuxième positions de vidage;
 - expulser à travers l'ouverture de sortie (19) les ordures contenues dans le compartiment d'acheminement (4, 5) en communication avec l'ouverture de sortie elle-même.
- 40
- 45
- 50
9. Dispositif de stockage de déchets dans un véhicule destiné à collecter séparément des déchets, comprenant:
- au moins un récipient de collecte (2) présentant
- 55
- au moins un premier et un deuxième compartiments d'acheminement (4, 5) délimités par au moins une cloison de séparation (3);
 - des premiers moyens de transfert (9a) pour insérer des premières ordures dans le compartiment d'acheminement (4);
 - des deuxième moyens de transfert (9b) pour insérer des deuxième ordures dans le deuxième compartiment d'acheminement (5);
 - ladite cloison de séparation (3) comprenant au moins une portion orientable (14) mobile dans le récipient de collecte (2) pour augmenter sélectivement le volume du deuxième compartiment d'acheminement (4, 5) dans lequel on a atteint un degré de remplissage qui est supérieur au degré de remplissage atteint dans l'autre compartiment d'acheminement, comprenant en outre des moyens de commande (13) agissant sur la cloison de séparation (3) pour positionner ladite portion orientable (14) à au moins une position de vidage ("D") dans laquelle un bord terminal (24) de la cloison de séparation (3) correspond exactement à un bord d'au moins une ouverture de sortie (19, 20) du récipient de collecte (2),
- caractérisé en ce que**, à la position de vidage ("D") le bord terminal (24) de la cloison de séparation (3) correspond exactement à un bord commun entre une première et une deuxième ouvertures de sortie (19, 20) obtenues sur le récipient de collecte (2), pourvues respectivement d'au moins une première et au moins une deuxième portes de fermeture (21, 22) et respectivement en communication avec les premier et deuxième compartiments d'acheminement (4, 5), où ledit dispositif comporte en outre au moins une barre de support (23) engagée à l'extrémité arrière du récipient de collecte (2) et définissant le bord commun entre les première et deuxième ouvertures de sortie (19, 20), ladite deuxième porte (22) étant engagée de manière oscillante à ladite barre de support (23).
10. Dispositif selon la revendication 9, dans lequel ladite portion orientable (14) est mobile par effet des actions de poussées exercées respectivement par les première et les deuxième ordures insérées dans les premier et deuxième compartiments d'acheminement (4, 5).
11. Dispositif selon la revendication 9, dans lequel lesdits moyens de commande (13) sont destinés à positionner sélectivement la portion orientable (14) à une première et une deuxième positions de vidage où le bord terminal (24) de la cloison de séparation (3) correspond exactement à un premier et respectivement un deuxième bord de la première ouverture de sortie pour mettre sélectivement les premier

et deuxième compartiments d'acheminement (4, 5) en communication avec la première ouverture elle-même.

12. Dispositif selon la revendication 9, comprenant en outre des moyens capteurs destinés à détecter et indiquer si on a atteint un degré prédéterminé de remplissage sélectivement dans chacun desdits compartiments d'acheminement (4, 5), lesdits moyens de commande (13) étant en mesure d'être mis en fonctionnement en réponse à des indications émises par les moyens capteurs pour déterminer le mouvement de la portion orientable (14) à l'intérieur du récipient de collecte (2). 5 10 15
13. Dispositif selon la revendication 12, **caractérisé en ce que** lesdits moyens de commande (13) sont destinés à positionner la portion orientable (14) de la cloison de séparation (3) à une pluralité de positions intermédiaires ("C") comprises entre une première et une deuxième positions limite ("A", "B"). 20
14. Dispositif selon la revendication 9, **caractérisé en ce que** lesdites première et deuxième portes de fermeture (21, 22) sont respectivement munies de premiers et deuxièmes moyens d'ouverture (25, 26) qui peuvent être mis en fonctionnement de manière indépendante l'une de l'autre pour permettre le vidage sélectif des premier et deuxième compartiments d'acheminement (4, 5). 25 30
15. Dispositif selon la revendication 9, **caractérisé en ce qu'**au moins une ouverture d'entrée (10, 11) est ménagée sur le récipient de collecte du côté opposé par rapport à l'ouverture de sortie (19, 20), lesdites premières et deuxièmes ordures étant insérées dans les compartiments d'acheminement respectifs (4, 5) à travers ladite au moins une ouverture d'entrée (10, 11). 35 40
16. Dispositif selon la revendication 9, comprenant en outre des moyens de compactage associés de manière opérationnelle à la portion orientable (14) de la cloison de séparation (3) pour compacter les ordures contenues dans l'un ou l'autre des compartiments d'acheminement (4, 5) simultanément à la mise en place de la portion orientable elle-même à la position de vidage. 45
17. Dispositif selon la revendication 16, **caractérisé en ce que** lesdits moyens de compactage comportent la même portion orientable (14) de la cloison de séparation (3), cette portion orientable étant destinée à exercer une action de poussée sur les ordures positionnées dans les compartiments d'acheminement (4, 5). 50 55
18. Dispositif selon la revendication 9, **caractérisé en**

ce qu'il comporte en outre des moyens de compensation (30) engagés de manière opérationnelle au récipient de collecte (2) et reliés à ladite au moins une portion orientable (14) de la cloison de séparation (3) pour la soutenir en équilibrant son poids.

FIG.1

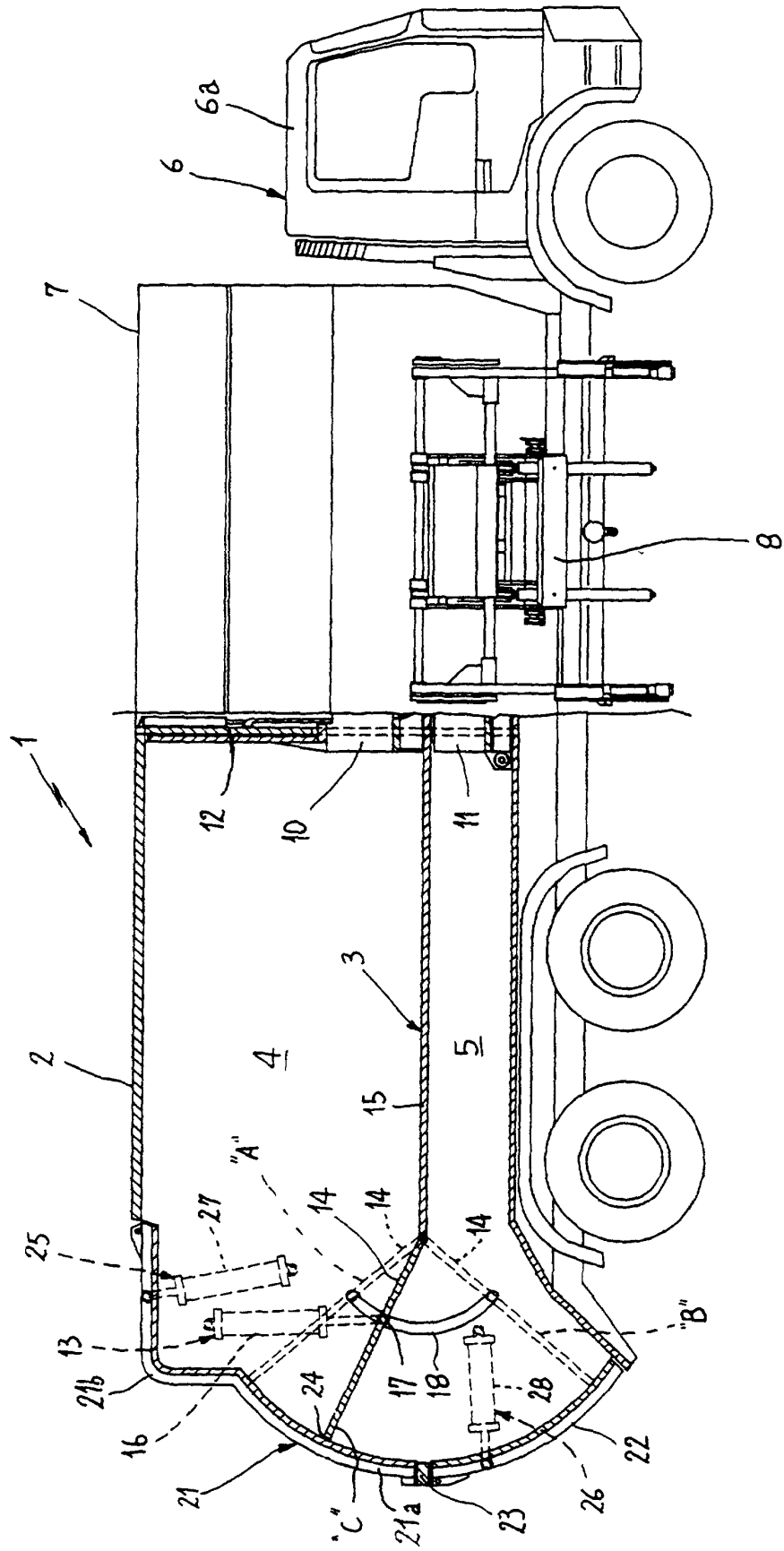

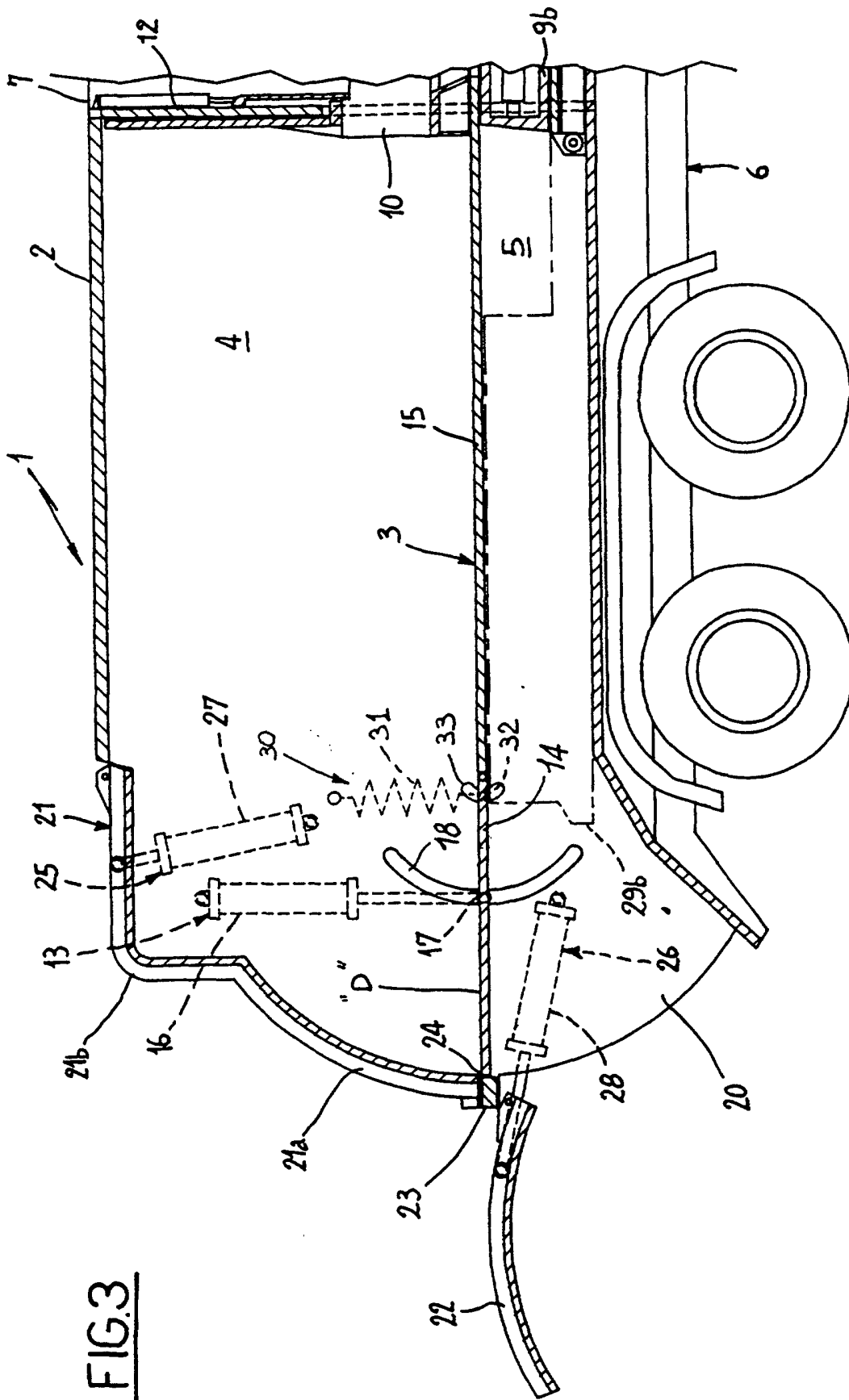

FIG. 3