



Europäisches Patentamt
European Patent Office
Office européen des brevets



(11) **EP 0 967 168 B1**

(12) **EUROPEAN PATENT SPECIFICATION**

(45) Date of publication and mention
of the grant of the patent:
27.03.2002 Bulletin 2002/13

(51) Int Cl.7: **B65H 54/28**

(21) Application number: **99109705.6**

(22) Date of filing: **17.05.1999**

(54) **Traverse apparatus having rotating wings**

Traversiervorrichtung mit rotierenden Flügeln

Dispositif de va-et-vient avec des ailes roulantes

(84) Designated Contracting States:
DE FR IT

(72) Inventor: **Kawarabashi, Tsukasa**
Kyoto-shi (JP)

(30) Priority: **25.06.1998 JP 17856898**
25.06.1998 JP 17856998

(74) Representative: **Liedl, Christine, Dipl.-Chem. et al**
Albert-Rosshaupter-Strasse 65
81369 München (DE)

(43) Date of publication of application:
29.12.1999 Bulletin 1999/52

(56) References cited:
EP-A- 0 823 393

(73) Proprietor: **MURATA KIKAI KABUSHIKI KAISHA**
Kisshoin, Minami-ku Kyoto-shi 601 (JP)

EP 0 967 168 B1

Note: Within nine months from the publication of the mention of the grant of the European patent, any person may give notice to the European Patent Office of opposition to the European patent granted. Notice of opposition shall be filed in a written reasoned statement. It shall not be deemed to have been filed until the opposition fee has been paid. (Art. 99(1) European Patent Convention).

Description

[0001] The present invention relates to a traverse apparatus according to the preamble of claim 1.

[0002] A known traverse apparatus as disclosed in EP-A-823393 defining the preamble of claim 1, having rotating wings of this kind traverses a yarn by rotating two rotating wings in opposite directions along a yarn guide that forms a yarn traverse track and that has turning points at the right and left ends, thus allowing the yarn to be transferred between the two rotating wings at the turning points.

[0003] In this conventional traverse apparatus, however, if the yarn is accidentally cut on the upstream side, causing the yarn to be free, the yarn leading to the traverse apparatus will be loose and will not be transferred appropriately between the rotating wings at the turning point, and in this case, the yarn will be rolled in the rotating wing past the turning point, and the free yarn will be wound around the rotating body at the root of the rotating wing. In addition, when the yarn is wound around the rotating body, the wound yarn must be removed. Since, however, the rotating body located at the root of the rotating wing is located in a narrow place constituting a drive device, the yarn can be removed only after the main parts of the traverse apparatus are disassembled. Accordingly, the removal operation requires much time and labor. Thus, this conventional traverse apparatus cannot preclude the yarn that is rolled in from being wound around the rotating body when a yarn cut occurred.

[0004] It is, therefore, an object of the present invention to provide a traverse apparatus having rotating wings that can reliably prevent the yarn from being wound around the rotating body on which the rotating wing is mounted.

[0005] To achieve this object, the present invention provides according to the characterizing portion of claim 1 a traverse apparatus having rotating wings comprising a cover member provided around a rotating body on which the rotating wing is mounted.

[0006] Experience shows that if the yarn is cut, the yarn that becomes free is rolled in by the upper rotating wing through the guide surface and travels to the rotating body on which the rotating wing is mounted. Due to the integral rotation of the rotating wings and the rotating body, the free yarn is further rolled in by the rotating wing and is wound around the rotating body. The present invention, however, is designed based on the principle that when the yarn is wound around a member that remains stationary, instead of rotating, or that rotates at a low speed, this member acts as a resistance force against the yarn, thus preventing the rotating wing from rolling in the yarn. In other words, the yarn rolled in by the rotating wing when the yarn is cut is contacted with the cover member so as to be subjected to a resistance force. This configuration prevents the yarn from being wound around the fixed or slowly-rotating cover mem-

ber.

[0007] Additionally, the present invention is a traverse apparatus wherein part of the top surface of an upper rotating wing may be located above the lower end of the cover member.

[0008] The yarn rolled in by the upper rotating wing travels to the rotating body along the top surface of the tip side of the rotating wing. Thus, by locating part of the top surface of the upper rotating wing above the cover member, the yarn is reliably guided to the cover member and is not guided to a position separate from the cover member.

[0009] Furthermore the present invention is a traverse apparatus wherein a yarn hooking section may be provided at the tip of the upper rotating wing.

[0010] When the yarn is accidentally cut, the yarn slides from the tip of the upper rotating wing toward the rotating body. During this movement, the yarn stops at the yarn hooking section so that the tip of the rotating wing guides the yarn that contacts the cover member. Thus, the yarn is reliably guided to the cover member.

[0011] The present invention is also a traverse apparatus wherein the cover member may have a yarn stopping section provided for preventing the yarn being wound around the cover member from falling onto the rotating body.

[0012] The yarn stopping section precludes the yarn contacting the cover member from slipping down from the cover member.

[0013] In addition to the cover member, a resistance force application means is preferably provided between the guide surface and the cover member to apply a resistance to the yarn drawn by the rotating wing from the guide surface toward the rotational center of the rotating wing. The resistance force application means helps form a wedge between an elastic member and the yarn guide. This action allows the yarn to enter the wedge, thereby increasing the resistance force.

[0014] When the resistance force application member is used to apply resistance force against the yarn, the number of times that the yarn travels toward the cover member decreases. This configuration almost completely prevents the yarn from being wound around the rotating body. In claims, "upper" and "lower" means the upper and lower positions relative to the yarn travelling direction, respectively.

Brief Description of the Drawing

[0015]

Figure 1 is a perspective view of the traverse apparatus having rotating wings according to the present invention.

Figure 2 is a side view showing the transfer of yarn at a left turning point in a traverse track.

Figure 3 is a side view showing the transfer of a yarn at a right turning point in the traverse track.

Figure 4 is a view of Figure 1 as seen from the top of this figure, mainly showing a yarn guide and rotating wings.

Figure 5 is a vertical sectional view of a traverse apparatus having rotating wings showing an example of the arrangement of another yarn cutting apparatus.

Figure 6 is a view of Figure 5 as seen from the A direction, mainly showing a drive mechanism.

Figure 7 is a view of Figure 5 as seen in the VII-VII direction, showing a traverse apparatus having rotating wings according to the present invention.

Detailed Description of the Preferred Embodiments

[0016] An embodiment of the present invention will be described with reference to the drawings. Figure 1 is a perspective view of a traverse apparatus having rotating wings according to the present invention, Figure 2 shows yarn being transferred at a turning point A, and Figure 3 shows yarn being transferred at a turning point B.

[0017] In a take-up winder, a plurality of traverse apparatuses having rotating wings U1, U2, U3... are normally arranged in a horizontal line. Figure 1 shows a traverse apparatus having rotating wing U1.

[0018] 1 is a yarn guide having a guide surface 1a that forms a traverse track, 2 is a rotating wing located above the yarn travelling direction so as to rotate counterclockwise around a traverse center 01 as seen from above, 3 is a rotating wing located below the yarn travelling direction so as to rotate clockwise around a center 02 located to the right of the traverse center 01 as seen from above, 4 is an auxiliary guide for the turning point A, 5 is an auxiliary guide for the turning point B, 41 is a plate spring stuck to the bottom surface of the yarn guide 1 near the turning point B and acting as a resistance force application means, and 51 is a fixed or stationary cover member provided around a rotating body 25 on which the upper rotating wing 2 is mounted.

[0019] In addition, 11 is a touch roller or a friction roller, 12 is a bobbin holder, 35 is a bobbin installed on the bobbin holder 12, and P is a package comprising a bobbin 35 with a yarn wound around it. 15 is a bracket supporting the auxiliary guide 4 via a block 16, and 17 is a bracket supporting the auxiliary guide 5 via the block 16.

[0020] A detailed structure of the traverse apparatus having rotating wings that transfers a yarn between the upper and lower rotating wings 2 and 3 will be described with reference to Figure 4.

[0021] In Figure 4, the upper rotating wing 2 has a slightly smaller diameter than the lower rotating wing 3 so that the tips of the rotating wings 2 and 3 are arranged along a vertical yarn path Y despite the diagonal arrangement of the rotating wings 2 and 3 shown in Figure 5. The upper rotating wing 2 has two tips 2a and 2b that are point-symmetrical around the center 01 and that are separate through an angle of 180° , while the lower ro-

tating wing 3 has two tips 3a and 3b that are point-symmetrical around the center 02 and that are separated by 180° . The center 01 of the upper rotating wing 2 and the center 02 of the lower rotating wing 3 are located on a reference line 13 and are mutually offset by a certain distance ϵ . A traverse centerline 14 is perpendicular to the reference line 13 and passes through the center 01 of the upper rotating wing 2.

[0022] Due to the offset between the centers 01 and 02, the yarn is transferred from the upper tip 2a to the lower tip 3a at the turning point B, and both the lower and upper tips 3a and 2b arrive at the turning point A. Consequently, while the rotating wings 2 and 3 rotate one turn in opposite directions, the tips 2a, 2b, 3a and 3b reciprocate the yarn once along a traverse track determined by the yarn guide 1 and the auxiliary guides 4 and 5. The number of tips of the rotating wings 2 and 3 is not limited to two, as the rotating wings 2 and 3 may have three tips that are separated by 120° . Furthermore, one of the rotating wings may have two tips, while the other has three tips, and their rotational angular velocities may be different with inverse rates of the number of the tips.

[0023] The auxiliary guides 4 and 5 assisting the transfer of the yarn via the brackets attached to the yarn guide 1 are disposed below the rotating wings 2 and 3 so that the yarn guide 1 and the auxiliary guides 4 and 5 sandwich the rotating wings 2 and 3 in the vertical direction. The auxiliary guide 4 has an outer guide surface 4a and the auxiliary guide 5 has an inner guide surface 5a that faces toward the traverse center 01. The bracket 15 in Figure 1 has a guide surface 15a that is offset from the traverse track along the yarn guide 1. In a take-up winder, the guide surface 15a holds the yarn removed from the rotating wings 2 and 3 by the operations of a yarn removal guide and a yarn moving guide (not shown in the drawings) when a bobbin is changed by means of the rotation of a turret.

[0024] A drive mechanism for rotating the rotating wings 2 and 3 in the opposite direction will be described with reference to Figures 5 and 6.

[0025] In Figure 5, a central shaft 23 is rotatably supported on a base plate 21 via a bearing 22. In addition, a hollow rotating body 25 is supported on the base plate 21 via a bearing 24 in such a way that it is free to rotate. The lower rotating wing 3 is attached to the lower end of the central shaft 23 via a bolt, and the upper rotating wing 2 is attached to the lower end of the rotating body 25 via a bolt. Furthermore, a drive shaft 27 is supported on the base plate 21 via a bearing 26 in such a way that it is free to rotate. A pulley 28 causes the drive shaft 27 to rotate. A timing pulley 29 is provided on the pulley 28 side of the drive shaft 27, with a gear 30 mounted opposite to the pulley 28. Another timing pulley 32 that meshes with a timing belt 31 passed across the timing pulley 29 is mounted on the central shaft 23, and the central shaft 23, that is, the lower rotating wing 3, rotates in the same direction as the drive shaft 27. A gear 33

that meshes with the gear 30 is mounted on the hollow rotating body 25, and the rotating body 25, that is, the upper rotating wing 2, rotates in the direction opposite to the direction of rotation of the drive shaft 27.

[0026] In Figure 6, when the engagement ratio between the gear 30 and the gear 33 is the same as the gear tooth ratio between the timing pulley 29 and the timing pulley 32, the upper and lower rotating wings 2 and 3 rotate at the same angular velocity in opposite directions. 34 is an idle pulley that applies tension to the timing belt 31.

[0027] Next, the conditions of the yarn at the turning points A and B will be described.

[0028] As in Figure 2 which shows the conditions at the turning point A, the yarn guide 1 is located above the upper and lower rotating wings 2 and 3, and the auxiliary guide 4 protruding outward from the side of a touch roller 11 is located below the upper and lower rotating wings 2 and 3. In other words, the auxiliary guide 4 is located only on the side of the traverse track in which the traverse center is located. The entire auxiliary guide 4 is located in such a way as to diagonally cross the vertical yarn path of the yarn Y along the touch roller 11. At the turning point A, the lower rotating wing 3 transfers the yarn to the upper rotating wing 2. At a point C, the rotating wing 2 is traversing the yarn towards the right, as viewed from Figure 1, along the yarn guide 1. The yarn guide 1 serves to put the yarn on the upper rotating wing 2, and not only determines the traverse track but also assists in the transfer of the yarn. The auxiliary guide 4, which assists the transfer of the yarn together with the yarn guide 1, only removes the yarn from the lower rotating wing 3, thereby minimizing the bending of the yarn at the auxiliary guide 4 so as not to obstruct the transfer of the yarn.

[0029] As in Figure 2, the structure in Figure 3 showing the conditions of turning point B includes the yarn guide 1 arranged on the upper and lower rotating wings 2 and 3, despite the difference in the extent of the protrusion of the yarn guide between Figure 2 and Figure 3. The auxiliary guide 5 located below the rotating wings 2 and 3, however, is situated in such a way as to protrude inward from opposite the touch roller 11. That is, the auxiliary guide 5 is located only opposite to the side of the traverse track in which the traverse center is located. At turning point B, the upper rotating wing 2 transfers the yarn to the lower rotating wing 3. At a point D, the rotating wing 3 is traversing the yarn towards the left, as viewed from Figure 1, along the yarn guide 1. The yarn guide 1 serves to remove the yarn from the upper rotating wing 2, and not only determines the traverse track but also assists in the transfer of the yarn. The auxiliary guide 5 bends the yarn to a larger degree than the auxiliary guide 4 in order to put the yarn on the lower rotating wing 3.

[0030] As shown in Figure 1, based on the above structure and operations, the traverse apparatus having rotating wings traverses the yarn by rotating the two ro-

tating wings 2 and 3 in opposite directions along the yarn guide 1 that forms the track of yarn traversing, and transfers the yarn between the rotating wings 2 and 3 at the turning points A and B.

[0031] This traverse apparatus having rotating wings is incorporated in, for example, a revolving type take-up winder for winding filament yarns from a spinning machine. If a yarn cut sensor should detect that the yarn has cut, the yarns leading to all traverse apparatuses U1, U2, U3... are cut on the upstream side of the take-up winder, and the yarns from the spinning machine are sucked. That is, if a yarn cut occurs, an about 4 to 5 meters of the yarn leading to the take-up winder becomes free. Then, the yarn leading to the traverse apparatus having rotating wings is loosened, and the upper rotating wing 2 rolls in the yarn past the turning point B to lead the free yarn to be wound around the outer circumference of the rotating body 25 on which the upper rotating wing 2 is mounted. This condition is shown by the yarn Y2 in Figure 1. Since the upper rotating wing 2 and the rotating body 25 rotate integrally, once the about 4 to 5 meters yarn starts to be wound around the rotating body 25, it does not stop until all the yarn has been wound around it.

[0032] The cover member 51 is provided to prevent the yarn from being wound around the rotating body when the yarn is cut, and the resistance force application member 41 is provided to reduce the number of times that the yarn travels toward the cover member 51.

[0033] The details of the cover member 51 will be described with reference to Figure 5.

[0034] The upper rotating wing 2 is attached to the lower end of the rotating body 25. Thus, a gap necessarily occurs between the lower end of a housing 21a and the upper rotating wing 2. The yarn rolled in by the upper rotating wing 2 enters the rotating body 25 through this gap and is wound around it.

[0035] Thus, the cover member 51 is provided under the housing 21a integrally therewith or separately therefrom so that the yarn rolled in by the upper rotating wing 2 comes in contact with the cover member 51. Since the housing 21a is formed in the base plate 21 that serves as a fixing member covering the drive mechanism, the cover member 51 is also fixed and stationary. When the yarn rolled in by the upper rotating wing 2 to move from the guide surface 1a toward the rotating body 25 contacts the fixed cover member 51, the cover member 51 acts as a resistance force against the yarn because it has a negative velocity relative to the travelling speed of the yarn rolled in by the upper rotating wing 2. This configuration prevents the yarn from being wound around the rotating body or stops the yarn from sliding over the cover member 51 after several rotations of winding at most, thereby allowing the yarn to be removed or cut from the upper rotating wing 2, which is rotating at a high speed.

[0036] The cover member 51 providing this function is shaped like a ring located around the rotating body

25. The yarn, which is rolled in after entering the yarn hooking section 2c from the tip of the upper rotating wing 2, travels to the cover member 51 in a line parallel with the top surface of the tip of the upper rotating wing 2.

[0037] Thus, the root portion of the upper rotating wing 2 which is closer to the rotating body 25 has a folded portion 2d so that the top surface of the tip of the upper rotating wing 2 is located above the top surface of the root portion. Thus, the top surface of the tip of the upper rotating wing 2 is located above the bottom of the cover member 51. Instead of the folded portion 2d, a step may be provided on the top surface of the upper rotating wing 2 by changing the thickness of the upper rotating wing 2. The step in the top surface is preferably provided at the root portion.

[0038] In addition, a flange-like yarn stopping section 52 is provided at the lower end of the cover member 51 on which the yarn is wound. The yarn stopping section 52 precludes the yarn contacting the circumference of the cover member 51 from falling down. The yarn stopping section 52 is not limited to a flange but may also be a groove. Where the yarn stopping section 52 is provided, the upper surface of the tip side of the folded portion 2d of the upper rotating wing 2 is positioned upper than the yarn stopping section 52.

[0039] In addition, as shown in Figure 1, the yarn hooking section 2c is provided at the tip of the upper rotating wing 2 that rolls in the yarn when the yarn is accidentally cut. The yarn rolled in by the upper rotating wing 2 slides from the tip to its root portion side, but is stopped upon entering the yarn hooking section 2c. Then, as shown in Figure 1, the yarn hooking section 2c guides the yarn being wound around the fixed cover member 51 by the upper rotating wing 2. Accordingly, the yarn hooking section 2c is preferably provided closer to tip than the step on the top surface.

[0040] To almost completely prevent the yarn from being wound around the rotating body upon a yarn cut, the resistance force application member 41 is provided in addition to the cover member 51. The details of the resistance force application member 41 will be explained with reference to Figure 4.

[0041] The resistance force application member 41 is provided near the turning point B and on the bottom surface of the yarn guide 1. This is because the yarn is likely to be rolled in from the turning point B. The resistance force application member 41 forms a wedge 43 between a plate spring 42 and the bottom surface of the yarn guide 1. The plate spring 42 has an elongated shape having at one end a short oblique edge 42a, a long oblique edge 42b, and a tip 42c at which both oblique edges intersect each other. The other end of the plate spring 42 that is further from the turning point B is pressed against and fixed to the bottom surface of the yarn guide 1 using a bolt 44.

[0042] A triangle part including the oblique edge 42b is folded upward at a edge 45 so that the tip 42c of the long oblique edge 42b and its opposite end 42d abut on

the bottom surface of the yarn guide 1. The area near the end 42d is folded back to surface-contact the bottom surface of the yarn guide 1. As a result, the tip 42c rises from the bottom surface of the yarn guide 1, and the size of the gap between the slope 42b and the bottom surface of the yarn guide 1 gradually decreases until it becomes zero at the end 42d due to the surface contact, thereby forming the wedge 43.

[0043] As shown in Figure 1, the wedge 43 formed by the long oblique edge 42b is disposed in the direction in which the yarn Y2 rolled in by the upper rotating wing 2 crosses a track 46 leading to the rotating body 25 along the bottom surface of the yarn guide 1. In addition, the tip 42c is located so as to catch the yarn moving along the track 46.

[0044] The resistance force application member 41 is not limited to the wedge formed between the plate spring 42 and the bottom surface of the yarn guide 1, but a separate wedge may be located on the yarn track formed upon a yarn cut. In summary, the resistance force application member 41 must only have a function for gradually applying resistance force against the yarn. In this sense, the plate spring 42 may be rigid, but is preferably an elastic member such as a plate spring in order to facilitate the encroaching of the yarn into the wedge 43 and allow the yarn encroached into the wedge to be released easily. A plate spring can be placed in a small area between the yarn guide 1 and the upper rotating wing 2. The yarn hooking section 2c also serves to guide the yarn to the resistance force application member 41.

[0045] Next, the operation of the traverse apparatus having rotating wings in the case of an accidental yarn cut will be described with reference to Figure 7. This figure corresponds to Figure 4 as seen from the VII-VII direction, that is, it shows the upper rotating wing 2 as seen from below. Thus, the bottom surface of the yarn guide 1 can be seen.

[0046] When the yarn is accidentally cut, the about 4 to 5 meters portion of the yarn becomes free on the upstream side, which corresponds to the far side in the paper. Since the free yarn is loose, the upper rotating wing 2 fails to transfer the yarn to the lower rotating wing 3 at point B. The yarn Y2 is continuously supplied from the far side in the paper, the upper rotating wing 2 rolls in the yarn to move it toward the outer circumferential surface of the rotating body 25 via the guide surface 1a of the yarn guide 1, as shown in Figure 7. First, the yarn Y2 slides from the tip 2a or 2b of the upper rotating wing 2 to its root portion side and enters the yarn hooking section 2c. Subsequently, the yarn Y2 is guided by the yarn hooking section 2c and is rolled in by following the track 46, as shown in Figure 7.

[0047] The track 46 leads from the turning point B via the rotating wing 2 to the rotating body 25 so that the yarn Y2 moves along the track 46. At the initial stage of this track 46, the yarn Y2 is sandwiched between the tip 42c of the plate spring 42 and the bottom surface of the

paper side of the yarn guide 1. In the middle of the track 46, the yarn Y2 enters the wedge 43 and gradually encroaches into the wedge 43 as it moves along the track 46. Then, a gradually increasing resistance force against the rolled-in yarn Y2 is applied. This resistance force prevents the yarn Y2 from following the upper rotating wing 2 and causes it to be released therefrom. When the resistance exceeds the tensile strength of the yarn Y2, the yarn Y2 may cut at, for example, the point E, but in either case, the yarn Y2 is released from the upper rotating wing 2 and is prevented from being wound around the rotating body 25. The yarn end encroaching into the wedge 43 between the plate spring 42 and the yarn guide 1 can be easily released by pushing up the plate spring 42 using an appropriate jig. Thus, a through-hole 1b through which a jig is passed to push up the plate spring 42 is formed in the yarn guide 1.

[0048] The plate spring 42 functioning as the resistance force application member 41 reduces the probability that the yarn travels toward the rotating body 25 upon a yarn cut. Even if the yarn Y2 travels toward the rotating body 25 due to its failure to be sandwiched by the plate spring 42, it contacts the fixed cover member 51 located along the outer circumference of the rotating body 25. The yarn hooking section 2c of the upper rotating wing 2 guides the yarn Y2 to ensure that it contacts the cover member 51. The yarn contacting the cover member 51 initially simply slides over the surface, but as the contact length (contact angle) increases, the resistance force increases to prevent it from sliding. Then, a braking force is applied to the yarn carried by the yarn hooking section 2c of the upper rotating wing 2, which is rotating at a high speed. This force releases the yarn from the yarn hooking section 2c without causing it to wind around the cover member 51, or before the yarn is wound around the member 51 at most several times.

[0049] The resistance force application member 41 releases the yarn from the upper rotating wing 2 in advance, thereby reducing the probability that the yarn will contact the cover member 51. If the yarn contacts the cover member 51 and is wound around it, it can be simply released from the cover member 51 as it will only have been wound around it a few times. The resistance force application member 41 merely assists in the operation, as the fixed cover member 51 alone can function sufficiently.

[0050] As described above, if the yarn cut, the present invention contacts the yarn with the cover member located around the rotating body so as to subject it to a resistance force and then release it from the rotating wing. Thus, whenever a yarn cut accidentally occurs, the present invention can reliably prevent the yarn from being wound around the rotating body on which the rotating wing is mounted.

[0051] The present invention ensures that the yarn contacts the cover member so as to prevent the yarn from traveling to the rotating body from the lower end of the cover member.

[0052] The present invention uses the yarn hooking section of the rotating wing to guide the yarn to the cover member more reliably upon a yarn cut.

[0053] The present invention precludes the yarn from falling from the cover member to prevent the yarn from travelling to the rotating body via the lower end of the cover member.

10 Claims

1. A traverse apparatus having rotating wings comprising;

a yarn guide (1) having a guide surface for forming a traverse track;

two rotating wings (2, 3) disposed at upper and lower positions in the yarn travelling direction that rotate in opposite directions along said yarn guide (1) to transfer the yarn to each other at a turning point (A, B) of said traverse track;

characterized by

a cover member (51) provided around a rotating body (25) on which said rotating wings (2, 3) are mounted whereby said cover member (51) is provided under a housing (21a) integrally therewith or separately therefrom so that the yarn rolled in by the upper rotating wing (2) comes in contact with the cover member (51) so as to be subjected to a resistance force.

2. A traverse apparatus having rotating wings according to Claim 1 **characterized in that** part of the top surface of the upper rotating wing (2) is located above the lower end of the cover member (51).

3. A traverse apparatus having rotating wings according to Claim 2 **characterized in that** a yarn hooking section (2c) is provided at the tip of said upper rotating wing (2).

4. A traverse apparatus having rotating wings according to any one of Claims 1 to 3 **characterized in that** said cover member (51) has a yarn stopping section (52) provided around said cover member (51) to prevent the yarn being wound around the cover member (51) from falling onto said rotating body (25).

5. A traverse apparatus having rotating wings according to any one of Claims 1 to 3 **characterized in that** a resistance force application means (41) to apply resistance against the yarn drawn by said rotating wing (2) from said guide surface toward the rotational center of the rotating wing is provided between said guide surface and said cover member.

6. A traverse apparatus having rotating wings accord-

ing to Claim 5 **characterized in that** said resistance force application means (41) forms a wedge (43) between an elastic member (42) and said yarn guide to allow the yarn to encroach into said wedge in order to increase the resistance force.

Patentansprüche

1. Traversiervorrichtung mit Drehflügeln, bestehend aus:

einer Fadenführung (1) mit einer Führungsfläche zur Bildung einer Traversierbahn, zwei Drehflügeln (2, 3), die in einer oberen und unteren Position in der Fadenlaufrichtung angeordnet sind und sich in entgegengesetzten Richtungen längs der Fadenführung (1) drehen, um den Faden an einem Umkehrpunkt (A, B) der Traversierbahn aufeinander zu transferieren,

gekennzeichnet durch,

ein Abdeckelement (51), das um einen Drehkörper (25) angeordnet ist, auf dem die Drehflügel (2, 3) befestigt sind, wobei das Abdeckelement (51) unter einem Gehäuse (21a) integral damit oder von diesem getrennt angeordnet ist, so daß der von dem oberen Drehflügel (2) eingerollte Faden mit dem Abdeckelement (51) in Kontakt kommt, um einer Widerstandskraft ausgesetzt zu werden.

2. Traversiervorrichtung mit Drehflügeln nach Anspruch 1, **dadurch gekennzeichnet, daß** ein Teil der oberen Oberfläche des oberen Drehflügels (2) über dem unteren Ende des Abdeckelements (51) liegt.
3. Traversiervorrichtung mit Drehflügeln nach Anspruch 2, **dadurch gekennzeichnet, daß** ein Fadenfangabschnitt (2c) an der Spitze des oberen Drehflügels (2) angeordnet ist.
4. Traversiervorrichtung mit Drehflügeln nach einem der Ansprüche 1 bis 3 **dadurch gekennzeichnet, daß** das Abdeckelement (51) einen Fadenstopabschnitt (52) hat, der um das Abdeckelement (51) vorgesehen ist, um zu Verhindern, daß der um das Abdeckelement (51) gewickelte Faden auf den Drehkörper (25) fällt.
5. Traversiervorrichtung mit Drehflügeln nach einem der Ansprüche 1 bis 3, **dadurch gekennzeichnet, daß** eine Widerstandskraft-Beaufschlagungseinrichtung (41) zwischen der Führungsfläche und dem Abdeckelement vorgesehen ist, um gegen den vom Drehflügel (2) von der Führungsfläche zur Drehmitte des Drehflügels gezogenen Faden einen

Widerstand auszuüben.

6. Traversiervorrichtung mit Drehflügeln nach Anspruch 5, **dadurch gekennzeichnet, daß** die Widerstandskraft-Beaufschlagungseinrichtung (41) einen Keil (43) zwischen einem elastischen Element (42) und der Fadenführung bildet, damit der Faden in den Keil eingreifen kann, um die Widerstandskraft zu erhöhen.

Revendications

1. Dispositif de déplacement avec des ailes rotatives comprenant :

un guichet-fil (1) ayant une surface de guidage pour former une voie de déplacement ;

deux ailes rotatives (2, 3) disposées à des positions inférieures et extérieures dans la direction de déplacement du fil qui tournent dans les directions opposées le long dudit guichet-fil (1) pour transférer le fil de l'une à l'autre à un point de rotation (A, B) de ladite voie de déplacement; **caractérisé par** :

un organe de couverture (51) prévu autour d'un corps rotatif (25) sur lequel sont montées lesdites ailes rotatives (2, 3), ledit organe de couverture (51) étant prévu sous un carter (21a) intégré ou séparé de sorte que le fil enroulé par l'aile rotative supérieure (2) vient en contact avec l'organe de couverture (51) de manière à subir une force de résistance.

2. Dispositif de déplacement avec des ailes rotatives selon la revendication 1 **caractérisé en ce qu'**une partie de la surface de dessus de l'aile rotative supérieure (2) est logée au-dessus de l'extrémité inférieure de l'organe de couverture (51).
3. Dispositif de déplacement avec des ailes rotatives selon la revendication 2, **caractérisé en ce qu'**une section d'accrochage de fil (2c) est prévue à la pointe de ladite aile rotative supérieure (2).
4. Dispositif de déplacement avec des ailes rotatives selon l'une des revendications 1 à 3, **caractérisé en ce que** ledit organe de couverture possède une section d'arrêt de fil (52) disposé autour dudit organe de couverture (51) pour empêcher le fil enroulé autour de l'organe de couverture de tomber sur ledit corps rotatif (25).
5. Dispositif de déplacement avec des ailes rotatives selon l'une des revendications 1 à 3, **caractérisé**

en ce qu'un moyen (41) pour l'application d'une force de résistance à l'encontre du fil tiré par lesdites ailes rotatives (2) de ladite surface de guidage à travers le centre de rotation de l'aile rotative est prévu entre ladite surface de guidage et ledit organe de couverture. 5

6. Dispositif de déplacement avec des ailes rotatives selon la revendication 5, **caractérisé en ce que** ledit moyen (41) d'application d'une force de résistance forme une cale (43) entre un organe élastique (42) et ledit guichet-fil pour permettre au fil d'entrer dans ladite cale afin d'augmenter la force de résistance. 10

15

20

25

30

35

40

45

50

55

FIG. 1

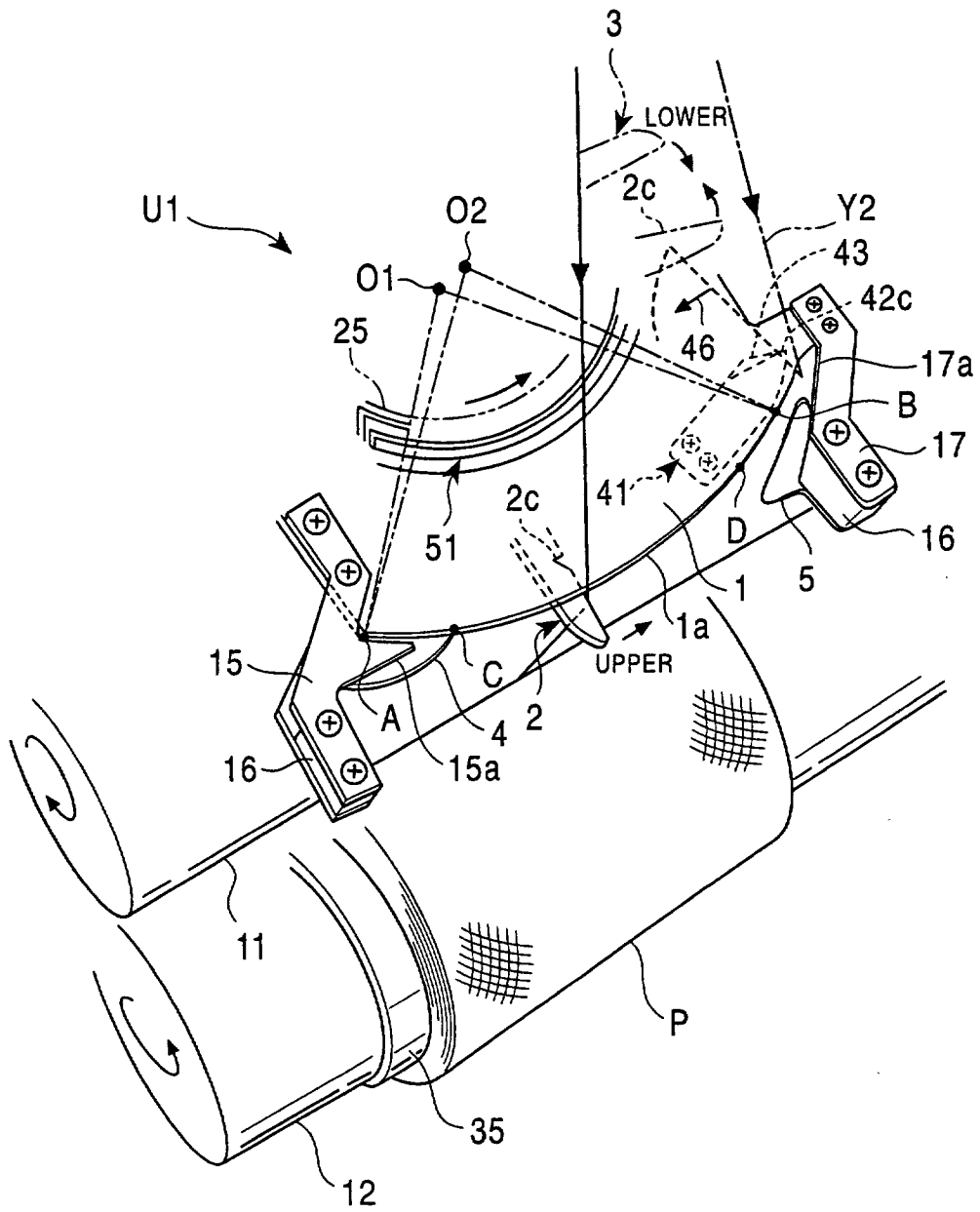

FIG. 2

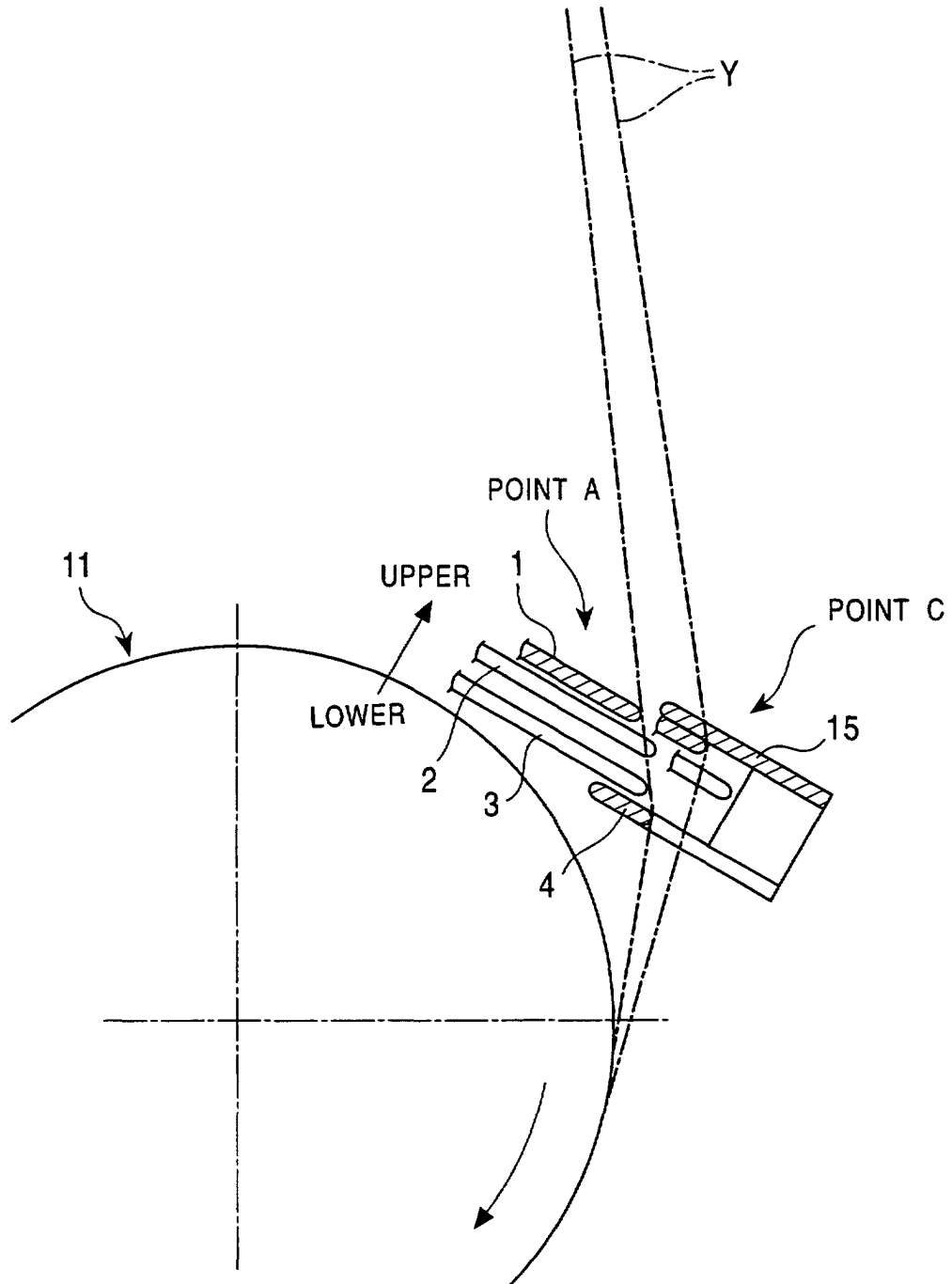

FIG. 3

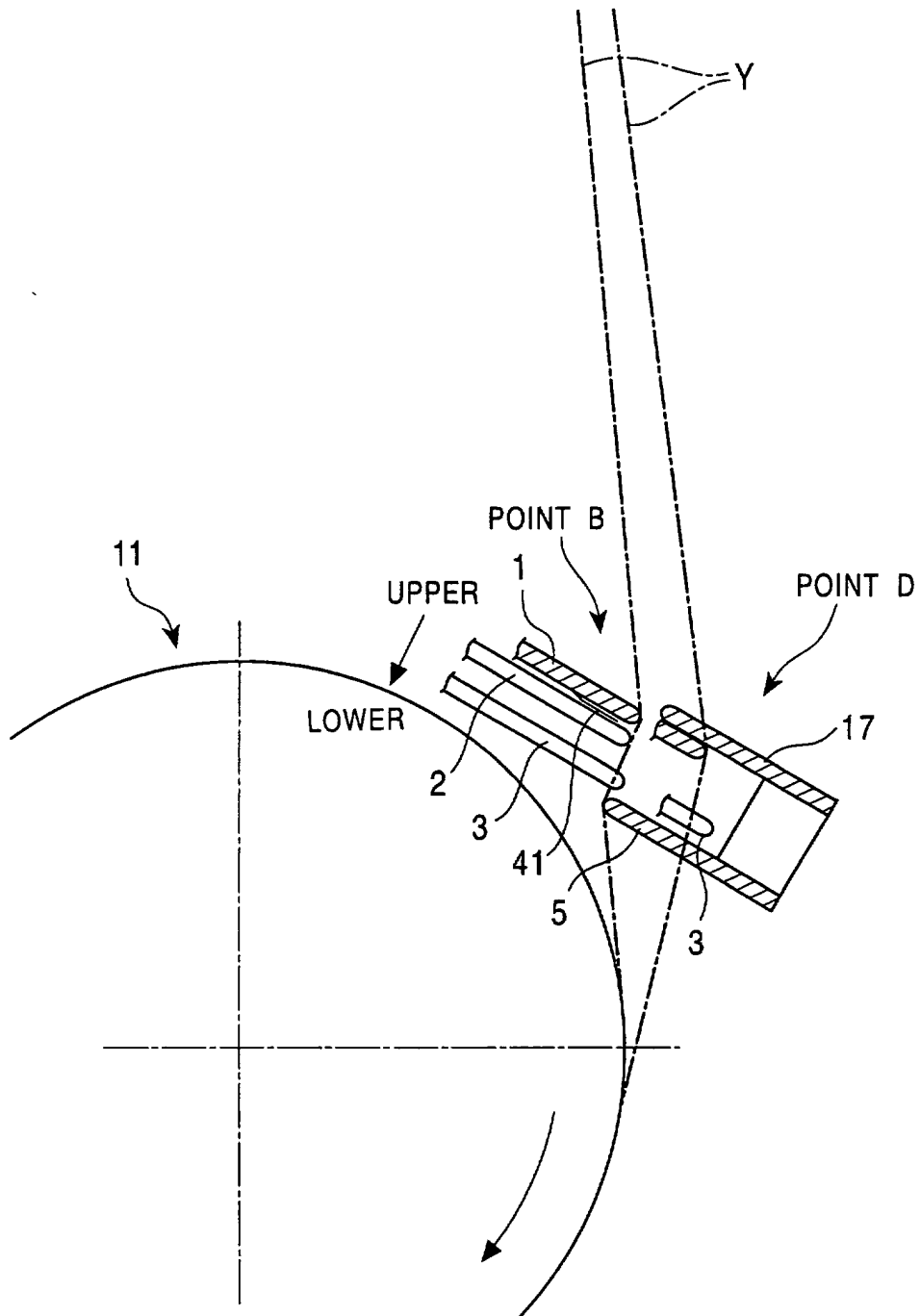

FIG. 4

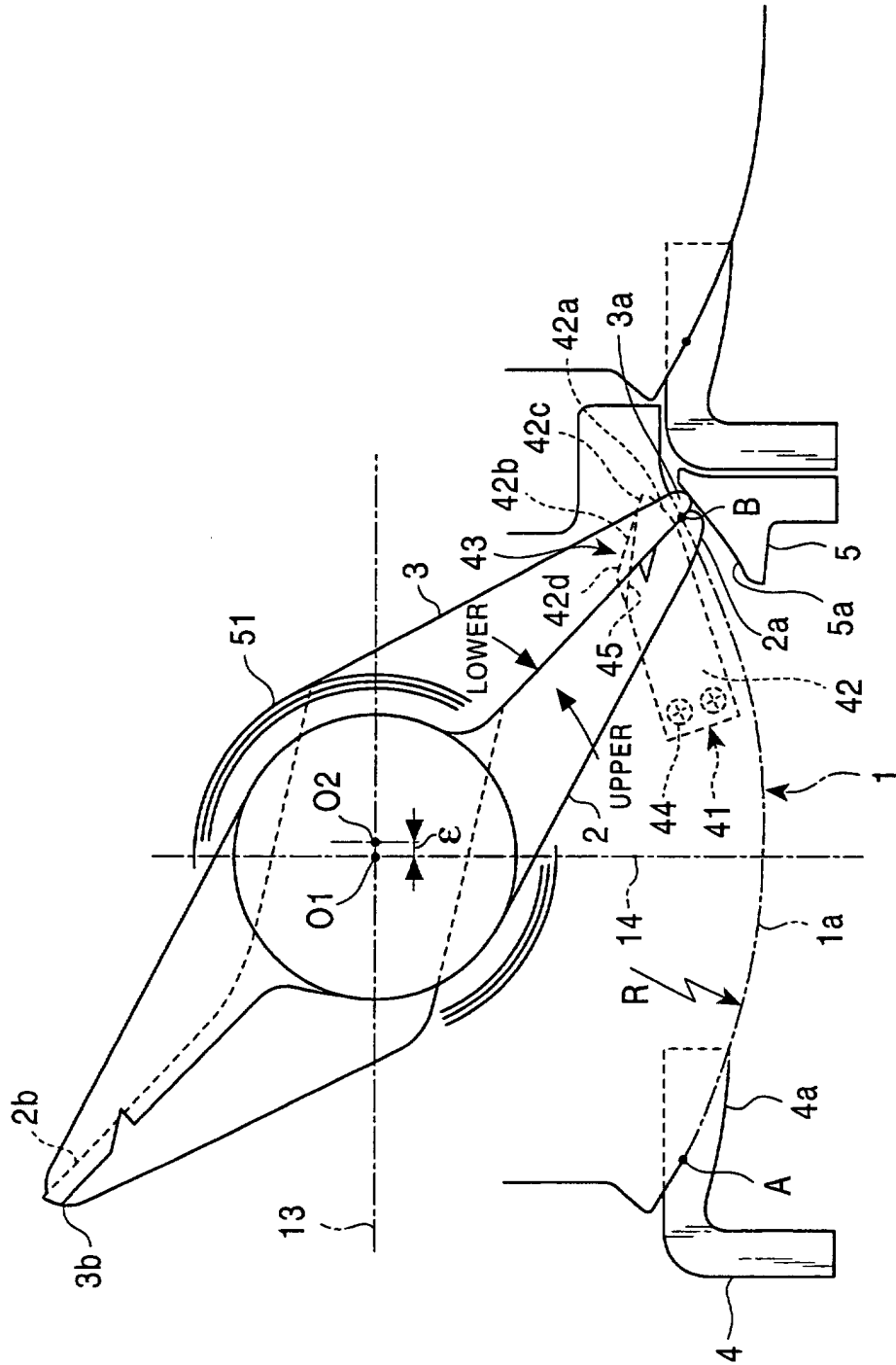

FIG. 5

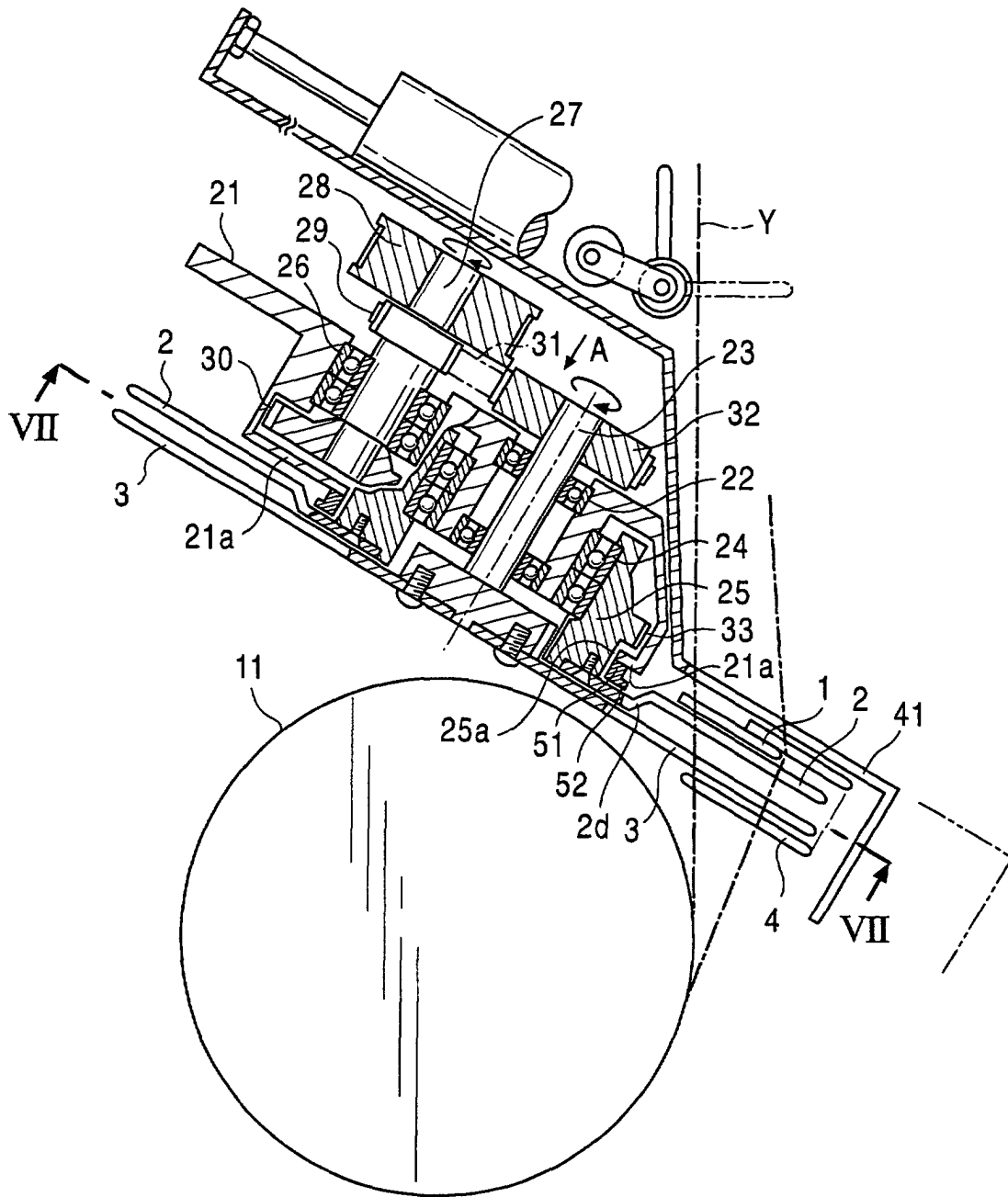

FIG. 6

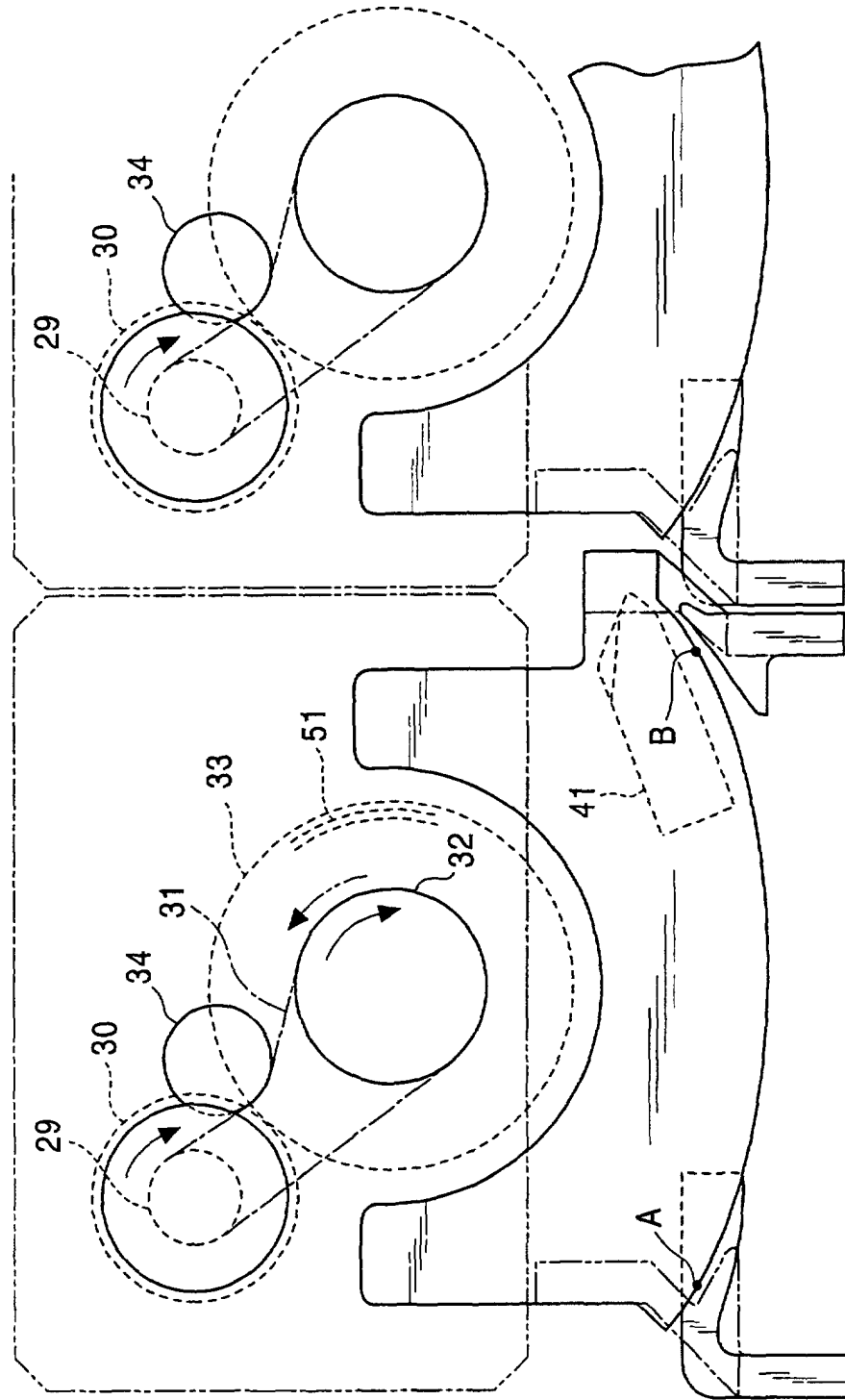

FIG. 7

