



Europäisches Patentamt
European Patent Office
Office européen des brevets



(11) **EP 0 969 177 B1**

(12) **EUROPEAN PATENT SPECIFICATION**

(45) Date of publication and mention
of the grant of the patent:
27.10.2004 Bulletin 2004/44

(51) Int Cl.7: **E06B 3/30**

(21) Application number: **99202020.6**

(22) Date of filing: **23.06.1999**

(54) **Connecting element for a composite section and composite section comprising the said connecting element**

Verbindungselement für ein Verbundprofil und mit diesem Verbindungselement versehenes Verbundprofil

Elément de raccord pour un profilé composite ainsi qu'un profilé composite pourvu d'un tel raccord

(84) Designated Contracting States:
**AT BE CH CY DE DK ES FI FR GB GR IE IT LI LU
MC NL PT SE**
Designated Extension States:
AL LT LV MK RO SI

(72) Inventor: **Zanoni, Edoardo**
20124 Milano (IT)

(30) Priority: **30.06.1998 IT MI981495**

(74) Representative: **Marchi, Massimo et al**
c/o Marchi & Partners s.r.l.,
Via Pirelli, 19
20124 Milano (IT)

(43) Date of publication of application:
05.01.2000 Bulletin 2000/01

(56) References cited:
EP-A- 0 546 800 WO-A-93/04256
DE-A- 2 906 340 DE-U- 8 531 078

(73) Proprietor: **HYDRO BUILDING SYSTEMS S.p.A.**
20060 Ornago (Milan) (IT)

EP 0 969 177 B1

Note: Within nine months from the publication of the mention of the grant of the European patent, any person may give notice to the European Patent Office of opposition to the European patent granted. Notice of opposition shall be filed in a written reasoned statement. It shall not be deemed to have been filed until the opposition fee has been paid. (Art. 99(1) European Patent Convention).

Description

[0001] The present invention relates to a connecting element for a composite section and a composite section comprising the said connecting element. Preferably, it relates to a metal-wood composite element for window and door frames.

[0002] Window and door frames formed from metal-wood composite sections are increasingly widely used both for aesthetic reasons and because of their properties of thermal and acoustic insulation.

[0003] Generally, a composite section comprises an outer metal section, an inner wooden facing element and one or more elements for connection between the section and the facing element.

[0004] In some composite sections, such as those described in EP-0 695 847, filed in the name of the present applicant, a connecting element consisting of a plastic strip provided with projections and tabs for fastening to the metal section and to the wooden facing element is used. The strip acts as a connection between the section and the wooden facing element and provides a seal and complete thermal insulation between them.

[0005] In the aforesaid composite sections, it is rather difficult to remove the wooden facing element if it becomes damaged and has to be replaced, owing to the fact that the strip is fixed securely to the section and to the facing element.

[0006] In other composite sections, the metal section and the wooden facing element are connected by a plurality of connecting elements consisting of shaped plastic blocks capable of being engaged in channels in the section and in the facing element. Rubber sealing gaskets are interposed between the section and the facing element, and these gaskets, together with the connecting blocks, also provide a thermally insulating action.

[0007] The shaped plastic blocks are basically of two types. The first type consists of two substantially rectangular plates, one lower and one upper, having mirror symmetry and in alignment, joined by a solid pin which is integral with a lever. The lever is disposed orthogonally with respect to the plates. A second type consists of two plates of substantially oval shape having mirror symmetry and in alignment with each other, made integral by means of a pin provided with a through hole.

[0008] To assemble a composite section by means of the lever blocks of the first type, the blocks are arranged in the channel of the metal section at predetermined distances from each other. Each block is positioned in the channel with the lower and upper plates disposed longitudinally and the lever disposed transversely. The wooden facing element is then mounted on the blocks, the upper plates of the blocks being inserted into its channel. At this point, the lever of each block is rotated through 90° so that it is disposed longitudinally with respect to the channels of the metal section and the facing element. When this is done, the upper and lower plates of the block are disposed transversely in the two chan-

nels and the metal section and the facing element are fixed to each other. The sealing gaskets are then inserted between them.

[0009] The composite sections using blocks of the second type are assembled in a similar way. Each block is positioned in the channel of the wooden facing element with the plates disposed longitudinally and is fixed to the facing element by means of a screw which passes into its perforated pin. After all the blocks have been mounted at a predetermined distance from each other, the metal section is mounted on the upper plates of the blocks. Each block is then rotated through 90° so that its plates are disposed transversely in the two channels of the metal section and of the wooden facing element.

This procedure is carried out by means of a special spanner which is inserted in the gap between the metal section and the facing element and which can grip the pin integral with the plates and turn it. The operation must be repeated for all the blocks, so that the wooden facing element and the metal section are fixed to each other.

[0010] The use of connecting blocks of the two types described above has a number of disadvantages, both during the assembly of a composite section and during the dismantling of the section, for example in order to replace a damaged wooden facing element.

[0011] During assembly, the blocks of the first type remain loose in the channel of the metal section when they are disposed longitudinally, and it is possible for them to be accidentally displaced from the positions in which they were placed, when the wooden facing element is placed against them. The spacing between the blocks may therefore be changed in a random way.

[0012] This disadvantage is not present with the blocks of the second type which are fixed in the channel of the wooden facing element by means of screws. However, a correct spacing between the blocks is achieved by a series of operations which increase the assembly time.

[0013] When a composite section comprising connecting blocks of one or the other type is dismantled, it is necessary to remove the sealing gaskets and then to rotate the blocks through 90° in the opposite direction to the direction of assembly. In this way, the plates of the blocks are disposed longitudinally in the channels of the metal section and of the facing element, and it is possible to separate the facing element from the metal section.

[0014] In the case of sections provided with blocks of the first type, the operation of rotating the blocks is carried out by inserting a tool with a hooked point into the gap between the metal section and the facing element in such a way as to grip the lever disposed longitudinally with respect to the channels. When force is applied with the tool, the lever is made to rotate until it is disposed transversely with respect to the channels, so that the plates of the block are disposed longitudinally with respect to the channels. This operation must be repeated

for all the blocks of the composite section. After this it is possible to remove the damaged facing element. The procedure entails a series of laborious operations which take up a great deal of time and push up the costs of the replacement of the wooden facing element.

[0015] Similar problems are encountered in the dismantling of composite sections provided with connecting blocks of the second type. In this case, in order to turn them 90° in the opposite direction to that of assembly, use is made of the same spanner that was used during assembly. The manipulation of the spanner in the gap between the facing element and the metal section is rather difficult, and it has to be repeated for all the blocks before the wooden facing element can be removed.

[0016] WO 93/04256 describes a coupling for compound profile members for doors or windows. Several keys are spaced along the profile, having opposite flanges, which are connected to the profiles by rotation. There is a key-shaped flange on one side and a disc-shaped flange on the other, connected by a neck with an intermediate rotation key. Said disc-shaped flange has a modified disc-shaped form with elastic interference protrusions on two orthogonal axes respectively coinciding one or the other with the plane passing on the longitudinal axis of said key-shaped flange. After having inserted the disc-shaped flange of the key inside the same first profile and having rotated it 45 degrees with respect to the interference axis in the first profile, said keys can scroll freely inside the respective groove of the first profile.

[0017] The objects of the present invention are a connecting element for a composite section and a composite section comprising the said connecting element which are free of the disadvantages of those described above.

[0018] A first aspect of the invention is a connecting element for a composite section comprising a first section having a first channel and a second section having a second channel, the said connecting element comprising a block consisting of two plates, one lower and one upper, each having a central axis, joined by a joining element, and a lever integral with the said joining element, the said lower plate being capable of being housed in the said first channel of the said first section and the said upper plate being capable of being housed in the said second channel of the said second section, characterized in that the said plates have central axes which are not in the same plane and are inclined at a predetermined angle to each other, the said lower plate assuming a first inclined position of engagement and a second inclined position of engagement with the said first channel to retain the said block at a predetermined point of the said first channel, while the said upper plate assumes a longitudinal position and a transverse position respectively with respect to the said second channel to fix, in the said transverse position, the said second section to the said first section.

[0019] According to a preferred embodiment of the invention, the said lever has a stop element which engages with a check means of the said first section to assume a first and a second limit position in which the said lower plate assumes the said first inclined position and the said second inclined position respectively, while the said upper plate assumes the said longitudinal position and the said transverse position respectively.

[0020] According to another preferred embodiment of the invention, the said plates are rotated with respect to the other through an angle ranging from approximately 10° to approximately 50°, and preferably through an angle of approximately 30°.

[0021] According to a further preferred embodiment of the invention, the said lever is inclined with respect to the said upper plate at an angle ranging from approximately 30° to approximately 60°, and preferably at an angle of approximately 45°.

[0022] A second aspect of the invention consists of a composite section comprising a first section having a first channel, a second section having a second channel and at least one connecting element, the said connecting element comprising a block consisting of two plates, one lower and one upper, each having a central axis, joined by a joining element, and a lever integral with the said joining element, the said lower plate being capable of being housed in the said first channel of the first section and the said upper plate being capable of being housed in the said second channel of the said second section, characterized in that the said plates have central axes which are not in the same plane and are inclined at a predetermined angle to each other, the said lower plate assuming a first inclined position of engagement and a second inclined position of engagement with the said first channel to retain the said block at a predetermined point of the said first channel, while the said upper plate assumes a longitudinal position and a transverse position respectively with respect to the said second channel to fix, in the said transverse position, the said second section to the said first section.

[0023] According to a preferred embodiment, a check means is associated with the said first channel of the said first section and the said lever is provided with a stop element which engages with the said check means to assume a first and a second limit position in which the said lower plate assumes the said first inclined position and the said second inclined position respectively, while the said upper plate assumes the said longitudinal position and the said transverse position respectively.

[0024] Preferably, the said check means consists of a rib on the said first section.

[0025] According to another preferred embodiment, the said first section comprises a tubular body having an inner face, an outer face and two lateral faces, the said inner face having the said first channel and the said check rib.

[0026] The connecting element according to the invention has numerous advantages.

[0027] The block with the two plates can be placed in the channel of a metal section in a very precise position, without the possibility of its accidental displacement. This is due to the fact that, when the upper plate is disposed longitudinally with respect to the channel, the lower plate, being out of alignment and rotated with respect to the upper plate, assumes an inclined position with respect to the longitudinal axis of the channel which causes it to interact partially with the edges of the channel. Thus the lower plate prevents the accidental extraction of the connecting element from the channel. Additionally, the stop element of the lever bears on the check of the metal section which acts as the limit stop, and prevents accidental sliding of the connecting element along the channel.

[0028] Another advantage of the connecting element according to the invention consists in the inclined disposition of the lever with respect to the upper plate, which makes the lever easily accessible from the outside both when locking and unlocking the connecting element.

[0029] Characteristics and advantages of the invention will now be explained with reference to an embodiment illustrated by way of non-restrictive example in the attached drawings, in which

Figs. 1 and 2 are views from above and below, respectively, of a connecting element for composite sections, made according to the invention;

Fig. 3 is a view from above of a metal section in which the connecting element shown in Figs. 1 and 2 is fitted;

Fig. 4 is a front view of the metal section shown in Fig. 3, of the connecting element shown in Figs. 1 and 2, and of a wooden facing element;

Fig. 5 is a front view of an assembled composite section, consisting of the metal section, the connecting element and the wooden facing element shown in Fig. 4.

[0030] Figs. 1 and 2 show a connecting element 1 comprising a block 2 consisting of two plates, 3 and 4, being the lower and upper plates respectively, joined by a joining pin 5. The pin 5 is integral with a lever 6. The lever 6 has a peg 7 projecting below which acts as a limit stop. The lever 6 also has an operating tab 8 projecting above.

[0031] The plates 3 and 4 have a substantially rectangular shape in plan with two opposite corners rounded. The plates 3 and 4 have longitudinal central axes 103 and 104 which are not in the same plane and are inclined at an angle of approximately 30° to each other. In other words, the plates 3 and 4 are out of alignment, being rotated with respect to each other through a predetermined angle about a longitudinal central axis of the pin 5. The angle of rotation between the plates 3 and 4 may range from approximately 10° to approximately 50°.

[0032] The lever 6 is inclined at an angle of approximately 45° to the plate 4. In other words, a longitudinal

central axis 106 of the lever 6 forms the said angle with the longitudinal central axis 104 of the plate 4. The angle of inclination of the lever 6 with respect to the plate 4 may range from approximately 30° to approximately 60°.

[0033] The connecting element 1 is used to assemble in a dismountable way a composite section 100 (Fig. 5) consisting of an aluminium section 10 and a wooden facing block 30. The composite metal-wood section 100 is suitable for the construction of a frame such as a window or door frame (not shown).

[0034] The aluminium section 10 (Figs. 3-5) comprises a tubular body 11 having a substantially rectangular cross-section. The tubular body 11 has an inner face 12, an outer face 13 and two lateral faces 14 and 15. The inner face 12 has a longitudinal channel 16 having inwardly projecting edges 116 and 216. The channel 16 is capable of housing the lower plate 3 of the connecting element 1, as will be explained subsequently. The face 12 also has a longitudinal rib 18 which acts as a check for the peg 7 of the lever 6. The outer face 13 has a stop fin 19 having a C-shaped seat 20 for a sealing gasket which is not shown. The lateral face 14 has a C-shaped seat 21 capable of housing a glazing retention section which is not shown. The lateral face 15 has a C-shaped seat 22 for another sealing gasket, which again is not shown, and a projecting fin 23 having a substantially Z-shaped cross-section.

[0035] The block 30 has a longitudinal channel 31 and two undercuts 32 and 33 (Fig. 4). The channel 31 is capable of housing the upper plate 4 of the connecting element 1 (Fig. 5), as will be explained subsequently. The fin 23 of the section 10 comes to bear on the undercut 32.

[0036] Fig. 3 shows the connecting element 1 in the positions assumed in the phases of assembly in the channel 16 of the section 10. Initially, the lower plate 3 of the connecting element 1 is inserted into the channel 16 in the longitudinal position (condition a)). The lever 6 is then rotated in the anti-clockwise direction, as shown by the arrow 25, until it brings the peg 7 to bear on the rib 18 (condition b)). In this condition, the lower plate 3 assumes a first position inclined at approximately 40° in the anti-clockwise direction to the longitudinal axis of the channel 16, and two of its corners are positioned under the edges 116 and 216 of the channel 16. In this way, the connecting element 1 remains locked to the channel and cannot be accidentally displaced. The upper plate 4, in turn, assumes a longitudinal position, aligned with the channel 16 and, therefore, also with the channel 31 of the block 30 (Fig. 4). At this point, the block 30 can be mounted on the connecting element by fitting the plate 4 into its channel 31. The lever 6 is then rotated through 90° in the anti-clockwise direction, as shown by the arrow 26, until the peg 7 is again made to bear against the rib 18 (condition c)). In this condition, the lower plate 3 assumes a second position inclined at approximately 40° in the clockwise direction to the longi-

tudinal axis of the channel 16 in which its other two corners are positioned under the edges 116 and 216 of the channel 16, while the upper plate 4 assumes a transverse position and is wedged into the channel 31 (Figs. 3 and 5) to join the block 30 and the section 10. Numerous connecting elements 1 are mounted in the channel 16 at predetermined distances, according to the procedure described above. In this way, the block 30 is fixed securely to the section 10.

[0037] If it is necessary to remove the block 30, the connecting element 1 can be displaced easily from condition c) to condition b) by a simple rotation of the lever 6 in the opposite direction to that of assembly. It is worth noting that the rotation of the connecting elements 1 does not alter their longitudinal positioning in the channel 16. This makes it unnecessary to re-adjust their spacing in the channel 16.

Claims

1. Connecting element (1) for a composite section (100), said composite section (100) comprising
 - a first section (10) having a first channel (16) and
 - a second section (30) having a second channel (31), the said connecting element (1) comprising
 - a block (2) consisting of two plates (3, 4), one lower plate (3) and one upper plate (4), each of the plates having a central axis (103, 104), the said lower plate (3) being capable of being housed in the said first channel (16) of the said first section (10) and the said upper plate (4) being capable of being housed in the said second channel (31) of the said second section (30),
 - a joining element (5) joining the upper and lower plates (3, 4), and
 - a lever (6) integral with the said joining element (5),

characterized in that the said plates (3, 4) have central axes (103, 104) which are not in the same plane and are inclined at a predetermined angle to each other, the said lower plate (3) able to take a first inclined position of engagement and a second inclined position of engagement with the said first channel (16) to retain the said block (2) at a predetermined point of the said first channel (16), while the said upper plate (4) is able to take a longitudinal position and a transverse position respectively with respect to the said second channel (31) to fix, in the said transverse position, the said second section (30) to the said first section (10).

2. Connecting element according to claim 1 wherein

said first section (10) has a check means (18), **characterized in that** the said lever (6) has a stop element (7) which engages with said check means (18) to assume a first and a second limit position in which the said lower plate (3) assumes the said first inclined position and the said second inclined position respectively, while the said upper plate (4) assumes the said longitudinal position and the said transverse position respectively.

3. Connecting element according to claim 1, **characterized in that** the central axes of said plates (3, 4) are rotated with respect to each other through an angle ranging from approximately 10° to approximately 50°, preferably approximately 30°.
4. Connecting element (1) according to claim 1, **characterized in that** the said lever (6) is inclined at an angle ranging from approximately 30° to approximately 60°, preferably approximately 45°, to the said upper plate (4).
5. Composite section (100) comprising a first section (10) having a first channel (16), a second section (30) having a second channel (31) and at least one connecting element (1) according to any of claims 1 to 4.
6. Composite section (100) according to claim 5, **characterized in that** the said check means (18) consists of a rib on the said first section (10).
7. Composite section (100) according to claim 5, **characterized in that** the said first section (10) comprises a tubular body (11) having an inner face (12), an outer face (13) and two lateral faces (14, 15), the said inner face (12) the said first channel (16) and the said check means (18).

Patentansprüche

1. Verbindungselement (1) für einen Verbundquerschnitt (100), wobei der Verbundquerschnitt (100) aufweist:
 - einen ersten Abschnitt (10), der einen ersten Kanal (16) aufweist, und
 - einen zweiten Abschnitt (30), der einen zweiten Kanal (31) aufweist,

wobei das Verbindungselement (1) aufweist

 - einen Block (2), der aus zwei Platten (3, 4) besteht, einer unteren Platte (3) und einer oberen Platte (4), wobei jede der Platten eine zentrale Achse (103, 104) aufweist, die untere Platte (3)

in dem ersten Kanal (16) des ersten Abschnitts (10) aufgenommen werden kann, und die obere Platte (4) in dem zweiten Kanal (31) des zweiten Abschnitts (30) aufgenommen werden kann,

- eine Verbindungselement (5), welches die obere und die untere Platte (3, 4) verbindet, und
- einen Hebel (6), der vereinigt mit dem Verbindungselement (5) ausgebildet ist,

dadurch gekennzeichnet, dass die Platten (3, 4) zentrale Achsen (103, 104) aufweisen, die nicht in derselben Ebene liegen, und in einem vorbestimmten Winkel schräg zueinander verlaufen, wobei die untere Platte (3) eine erste Schrägposition des Eingriffs mit dem ersten Kanal (16) einnehmen kann, um den Block (2) an einem vorbestimmten Punkt des ersten Kanals (16) zu halten, während die obere Platte (4) eine Längsposition und eine Querposition in Bezug auf den zweiten Kanal (31) einnehmen kann, um in der Querposition den zweiten Abschnitt (30) an dem ersten Abschnitt (10) zu befestigen.

2. Verbindungselement nach Anspruch 1, bei welchem der erste Abschnitt (10) eine Sperrvorrichtung (18) aufweist, **dadurch gekennzeichnet, dass** der Hebel (6) ein Anschlagenelement (7) aufweist, das in Eingriff mit der Sperrvorrichtung (18) gelangt, um eine erste und zweite Grenzlage einzunehmen, in welcher die untere Platte (3) die erste Schrägposition bzw. die zweite Schrägposition einnimmt, während die obere Platte (4) die Längsposition bzw. die Querposition einnimmt.

3. Verbindungselement nach Anspruch 1, **dadurch gekennzeichnet, dass** die zentralen Achsen der Platten (3, 4) in Bezug aufeinander über einen Winkel gedreht sind, der im Bereich zwischen etwa 10 ° und etwa 50 ° liegt, vorzugsweise um etwa 30 °.

4. Verbindungselement (1) nach Anspruch 1, **dadurch gekennzeichnet, dass** der Hebel (6) schräg in einem Winkel im Bereich von etwa 30 ° bis etwa 60 °, vorzugsweise etwa 45 °, zu der oberen Platte (4) angeordnet ist.

5. Verbundquerschnitt (100), der einen ersten Abschnitt (10) aufweist, der mit einem ersten Kanal (16) versehen ist, einen zweiten Abschnitt (30), der mit einem zweiten Kanal (31) versehen ist, und zumindest ein Verbindungselement (1) nach einem der Ansprüche 1 bis 4.

6. Verbundquerschnitt (100) nach Anspruch 5, **dadurch gekennzeichnet, dass** die Sperrvorrichtung

(18) aus einer Rippe auf dem ersten Abschnitt (10) besteht.

7. Verbundquerschnitt, (100) nach Anspruch 5, **dadurch gekennzeichnet, dass** der erste Abschnitt (10) einen rohrförmigen Körper (11) aufweist, der eine innere Oberfläche (12), eine äußere Oberfläche (13), und zwei Queroberflächen (14, 15) aufweist, wobei die innere Oberfläche (12) den ersten Kanal (16) und die Sperrvorrichtung (18) aufweist.

Revendications

1. Élément de raccordement (1) pour une section composite (100),
ladite section composite (100) comprenant :

- une première section (10) comportant un premier canal (16) et
- une deuxième section (30) comportant un deuxième canal (31),

ledit élément de raccordement (1) comprenant :

- un bloc (2) consistant en deux plaques (3, 4), une plaque inférieure (3) et une plaque supérieure (4), chacune des plaques ayant un axe central (103, 104), ladite plaque inférieure (3) pouvant être logée dans ledit premier canal (16) de ladite première section (10) et ladite plaque supérieure (4) pouvant être logée dans ledit deuxième canal (31) de ladite deuxième section (30),
- un élément de liaison (5) reliant les plaques supérieure et inférieure (3, 4), et
- un levier (6) d'un seul tenant avec ledit élément de liaison (5),

caractérisé en ce que lesdites plaques (3, 4) ont des axes centraux (103, 104) qui ne sont pas dans le même plan et qui sont inclinés selon un angle prédéterminé l'un par rapport à l'autre, ladite plaque inférieure (3) étant capable d'adopter une première position inclinée de mise en prise et une deuxième position inclinée de mise en prise avec ledit premier canal (16) afin de retenir ledit bloc (2) au niveau d'un point prédéterminé dudit premier canal (16), tandis que ladite plaque supérieure (4) est capable d'adopter une position longitudinale et une position transversale respectivement par rapport audit deuxième canal (31) afin de fixer, dans ladite position transversale, ladite deuxième section (30) à ladite première section (10).

2. Élément de raccordement selon la revendication 1, dans lequel ladite première section (10) comporte

des moyens de contrôle (18), **caractérisé en ce que** ledit levier (6) comporte un élément d'arrêt (7) qui vient en prise avec lesdits moyens de contrôle (18) afin d'adopter une première et une deuxième positions limites dans lesquelles ladite plaque inférieure (3) adopte ladite première position inclinée et ladite deuxième position inclinée respectivement, tandis que ladite plaque supérieure (4) adopte ladite position longitudinale et ladite position transversale respectivement.

5

10

3. Élément de raccordement selon la revendication 1, **caractérisé en ce que** les axes centraux desdites plaques (3, 4) sont tournés l'un par rapport à l'autre d'un angle allant d'environ 10° à environ 50°, de préférence d'environ 30°.
4. Élément de raccordement (1) selon la revendication 1, **caractérisé en ce que** ledit levier (6) est incliné d'un angle allant d'environ 30° à environ 60°, de préférence d'environ 45°, par rapport à ladite plaque supérieure (4).
5. Section composite (100) comprenant une première section (10) comportant un premier canal (16), une deuxième section (30) comportant un deuxième canal (31) et au moins un élément de raccordement (1) selon l'une quelconque des revendications 1 à 4.
6. Section composite (100) selon la revendication 5, **caractérisée en ce que** lesdits moyens de contrôle (18) consistent en une nervure sur ladite première section (10).
7. Section composite (100) selon la revendication 5, **caractérisée en ce que** ladite première section (10) comprend un corps tubulaire (11) comportant une face intérieure (12), une face extérieure (13) et deux faces latérales (14, 15), ladite face intérieure (12) comportant ledit premier canal (16) et lesdits moyens de contrôle (18).

15

20

25

30

35

40

45

50

55

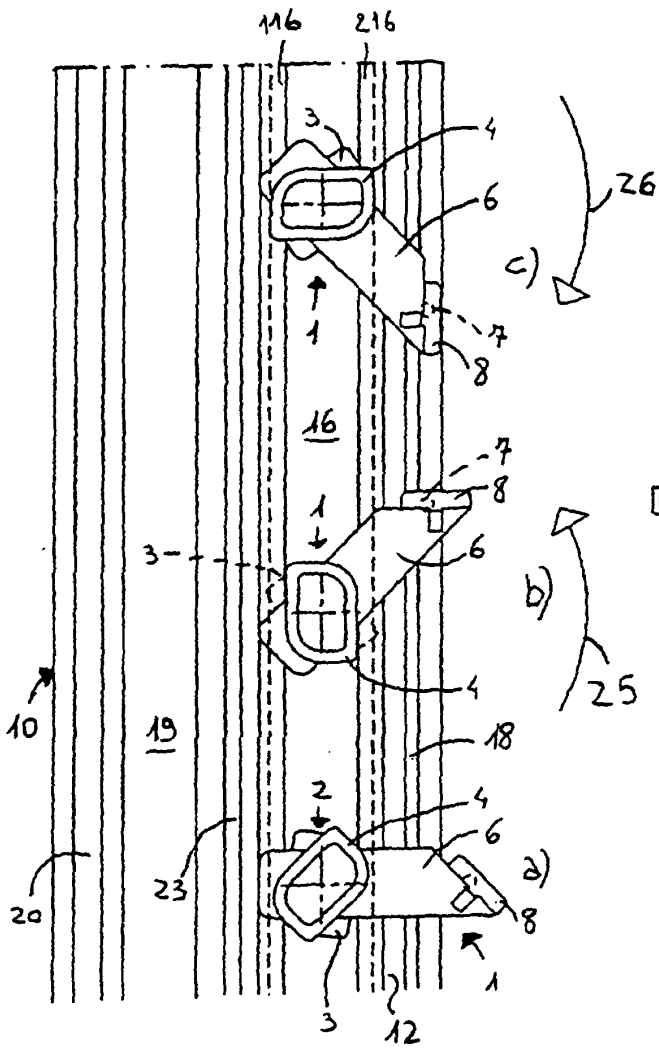

FIG. 3

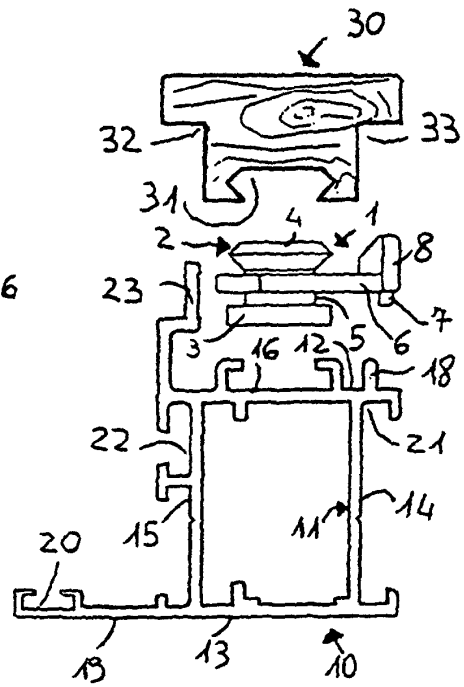

FIG. 4

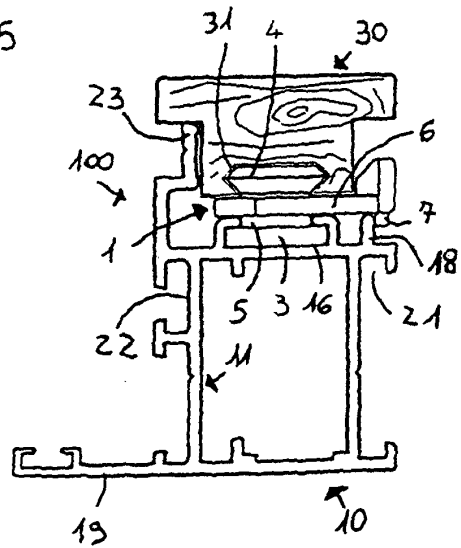

FIG. 5

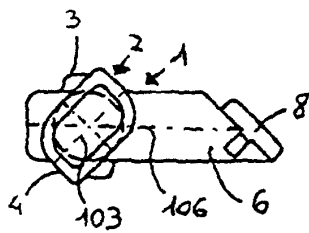

FIG. 1

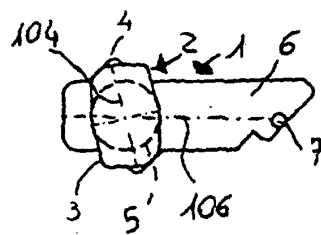

FIG. 2