



Europäisches Patentamt
European Patent Office
Office européen des brevets



(11) **EP 0 969 244 B1**

(12) **EUROPEAN PATENT SPECIFICATION**

(45) Date of publication and mention
of the grant of the patent:
01.12.2004 Bulletin 2004/49

(51) Int Cl.7: **F21S 8/04**

(21) Application number: **99202086.7**

(22) Date of filing: **29.06.1999**

(54) **Lighting system in particular for use in a tennis hall**

Beleuchtungseinrichtung, insbesondere für eine Tennishalle

Système d'éclairage, notamment pour une salle de tennis

(84) Designated Contracting States:
AT BE CH DE DK FR GB LI LU NL SE

• **Lie, A.B.K.**
7559 JM Hengelo (NL)

(30) Priority: **01.07.1998 NL 1009535**

(74) Representative: **Lips, Hendrik Jan George, Ir.**
HAAGSCH OCTROOIBUREAU
Breitnerlaan 146
2596 HG Den Haag (NL)

(43) Date of publication of application:
05.01.2000 Bulletin 2000/01

(73) Proprietor: **Aerolux International B.V.**
7759 JM Hengelo (NL)

(56) References cited:
DE-A- 2 242 309 **DE-A- 3 008 339**
DE-A- 4 410 898

(72) Inventors:
• **De Goeij, G.P.J.**
7573 AZ Oldenzaal (NL)

EP 0 969 244 B1

Note: Within nine months from the publication of the mention of the grant of the European patent, any person may give notice to the European Patent Office of opposition to the European patent granted. Notice of opposition shall be filed in a written reasoned statement. It shall not be deemed to have been filed until the opposition fee has been paid. (Art. 99(1) European Patent Convention).

Description

[0001] The invention relates to a lighting system for a tennis court, in particular for use in a tennis hall, employing lighting armatures each comprising at least one lamp mounted within a reflector, said lighting armatures being arranged in two parallel rows in longitudinal direction of a court.

[0002] Such a lighting system is known from DE-A-2242309. There, the lighting armatures are directed to the inner wall of the hall so that the rays of light emitted by the lighting armatures are reflected towards the court by the wall.

[0003] By applying such an indirect lighting system, the energy absorbed by it will not be used efficiently. Furthermore, it is still possible to look in the reflectors, so that it is desirable to cover them by means of a grid. This further reduces the efficiency of the system.

[0004] It will be obvious that when playing tennis it is not only desirable to obtain a proper illumination of the court, but it should also be possible to follow the path of the ball during the game. The movements of the opponents should also be clearly visible. All this requires a certain light intensity and in particular a uniform lighting across the entire space above the court.

[0005] The object of the invention is to design the lighting system in such a way, that an optimum efficiency is achieved and that a suitable light distribution across the entire space above the court is obtained.

[0006] According to the invention, this is achieved in that at least eight lighting armatures are employed, being arranged alongside the court in two rows spaced apart and each comprising at least four armatures in such a way, that at least four primary lighting armatures are situated at a horizontally measured distance between 3.75 m and 4.75 m from the net and at a height between 6 m and 8 m above the court and that at least four secondary lighting armatures are situated at a distance between 12 m and 13.5 m from the net and at a height between 5 m and 6 m, said lighting armatures being provided with high-pressure discharge lamps.

[0007] The primary lighting armatures will be positioned in particular at a distance of 4.25 m from the net and at a height of 7 m, whereas the secondary lighting armatures will be positioned at a distance of 12.75 m from the net and at a height of 5.5 m.

[0008] The two rows each comprising at least four lighting armatures will be preferably be mounted almost above the sidelines of a court. There, the rays of light from the armatures are aimed directly at the tennis court.

[0009] Since the secondary lighting armatures are required to cover a less large part of the space above the court, it will be provided for, that the primary lighting armatures can diffuse almost twice as much light as the secondary lighting armatures.

[0010] In order to achieve this in a simple way, it can be provided for, that the primary lighting armatures hold two high-pressure discharge lamps of almost 400 Watt

each and the secondary lighting armatures hold one such lamp.

[0011] Switching means can be provided, by means of which one of the two lamps present in the primary lighting armatures can be switched off. This can be done when playing for leisure. Thus, energy can be saved.

[0012] In particular, the lighting armatures will be designed in such a way, that they have a diffuse, flat, asymmetrical light distribution both in longitudinal direction and transverse direction. Thus, there is no need for using so-called grids for covering the reflector against looking in.

[0013] It has turned out that the lighting system according to the invention, at a relatively low power consumption, comes up to the standards and guidelines valid in Europe for the illumination of tennis halls.

[0014] It has also been found that the nuisance which players might experience from the lighting system is within highly acceptable limits.

[0015] The lighting level across 45° at 1.5 m above the court was measured. With a uniformity of approximately 0.6 between the minimum and the average lighting level, the lighting level at a height of 1.5 m proved to be approximately 85 % of the level on the court.

[0016] The invention is further explained by way of an embodiment, shown in the drawing, in which:

Fig. 1 shows schematically a plan view of a lighting system according to the invention above a court;

Fig. 2 shows schematically a cross-section across a tennis hall containing the lighting system according to Fig. 1 on a smaller scale;

Fig. 3 shows schematically a plan view of the hall according to Fig. 2 in which two courts have been provided;

Fig. 4 shows schematically a side view of a lighting armature applied with the lighting system according to the Figs. 1, 2 and 3;

Fig. 5 shows schematically a rear view of the lighting armature of Fig. 4; and

Fig. 6 shows schematically a cross-section across the lighting armature according to the line VI - VI of Fig. 4.

[0017] Figures 1 and 2 show a tennis hall 1 containing the court 2. The position of the net is indicated by 3, the position of the baselines by 4, and the position of the longitudinal lines by 5. As shown in Fig. 3, it is also possible that two courts 2 have been provided in one single hall.

[0018] Four primary lighting armatures 6 have been mounted at a distance P from the net 3, with P equalling 4.25 m in particular. The height HP above the court 2 is 7 m in particular.

[0019] Four secondary lighting armatures 7 have been mounted at a distance S from the net 3, with S equalling 12.75 m in particular. The height HS above the court 2 is 5,5 m in particular.

[0020] The lighting armatures 6 and 7 will be situated almost above the longitudinal lines 5.

[0021] Figures 4, 5 and 6 show the lighting armatures 6 and 7 in more detail, each consisting of a reflector 8 having fittings 9 mounted thereon for receiving high-pressure discharge lamps 10. The secondary lighting armatures 7 need only contain one single lamp 10. Said lamp will then preferably be situated at the largest distance to the net.

[0022] The lighting armatures 6 and 7 can be suspended on chains 11 from the roof 12 of the hall or be fastened in another way.

[0023] When playing for leisure, one of the two lamps 10 in the primary armatures 6 can be switched off. To that end, switching means not further indicated can be provided.

[0024] It will be obvious, that only one possible embodiment of a lighting system according to the invention has been illustrated in the drawing and described above and that many changes can be made without leaving the inventive idea, as it is indicated in the claims.

Claims

1. Lighting system for a tennis court, in particular for use in a tennis hall (1), comprising lighting armatures (6, 7) each comprising at least one high pressure discharging lamp (10) mounted within a reflector (8), said lighting armatures being arranged in two parallel, spaced apart rows in longitudinal direction alongside a court, each row comprising at least four lighting armatures (6,7), **characterized in that**, the armatures are asymmetrical in longitudinal direction, and two primary armatures (6) from each row, respectively are positioned at a horizontally measured distance (P) between 3.75 m and 4.75 m from the net (3) and at a height (HP) between 6 m and 8 m essentially above the sidelines of the court (2), two secondary armatures (7) from each row, respectively are positioned at a horizontally measured distance (S) between 12 m and 13.5 m from the net (3) and at a height (HS) between 5 m and 6 m essentially above the sidelines of the court (2), the primary lighting armatures of 400 Watt (6) having each two high-pressure discharge lamps (10) and the secondary lighting armatures (7) having each one such high-pressure discharge lamp (10), and that the light outlet openings of the armatures are lying approximately in a horizontal plane facing downward.
2. Lighting system according to claim 1, **characterized in that** the primary lighting armatures (6) are positioned at a horizontally measured distance (P) of 4.25 m from the net and at a height (HP) of 7 m essentially above the sidelines of the court (2),

four secondary lighting armatures (7) are positioned at a horizontally measured distance (S) of 12.75 m from the net and at a height (HS) of 5.5 m essentially above the sidelines of the court (2).

3. Lighting system according to claim 1-2, **characterized in that** switching means are provided, by means of which one of the two lamps in the primary armatures can be switched off.

Patentansprüche

1. Beleuchtungssystem für einen Tennisplatz, insbesondere für die Verwendung in einer Tennishalle (1), enthaltend Beleuchtungsarmaturen (6,7) welche jeweils wenigstens eine Hochdruck-Entladungslampe (10) enthalten, die innerhalb eines Reflektors (8) angeordnet ist, wobei besagte Beleuchtungsarmaturen in zwei parallelen, beabstandeten Reihen in Längsrichtung entlang des Platzes angeordnet sind, wobei jede Reihe jeweils vier Beleuchtungsarmaturen (6,7) umfasst, **dadurch gekennzeichnet, daß** die Armaturen in Längsrichtung asymmetrisch sind und zwei Hauptarmaturen (6) aus jeder Reihe jeweils in einem horizontal gemessenen Abstand (P) zwischen 3,75 m und 4,75 m vom Netz (3) und in einer Höhe (HP) zwischen 6 m und 8 m im wesentlichen oberhalb der Seitenlinien des Platzes (2) positioniert sind, zwei Nebenarmaturen (7) aus jeder Reihe jeweils in einem horizontal gemessenen Abstand (S) zwischen 12 m und 13,5 m vom Netz (3) und in einer Höhe (HS) zwischen 5 m und 6 m im wesentlichen oberhalb der Seitenlinie des Platzes (2) positioniert sind, die Hauptbeleuchtungsarmaturen (6) mit 400 Watt jede zwei Hochdruck-Entladungslampen (10) aufweisen und die Nebenbeleuchtungsarmaturen (7) jede eine solche Hochdruck-Entladungslampe (10) aufweisen, und daß die Lichtaustrittsöffnungen der Armaturen ungefähr in einer Ebene liegen und nach unten gerichtet sind.
2. Beleuchtungssystem nach Anspruch 1, **dadurch gekennzeichnet, daß** die Hauptbeleuchtungsarmaturen (6) in einem horizontal gemessenen Abstand (P) von 4,25 m vom Netz und in einer Höhe (HP) 7 m im wesentlichen oberhalb der Seitenlinien des Platzes (2) positioniert sind, vier Nebenbeleuchtungsarmaturen (7) in einem horizontal gemessenen Abstand (S) von 12,75 m vom Netz und in einer Höhe (HS) von 5,5 m im wesentlichen oberhalb der Seitenlinien des Platzes (2) positioniert sind.
3. Beleuchtungssystem nach einem der Ansprüche

1-2, **dadurch gekennzeichnet, daß** Schaltermittel vorgesehen sind, durch welche eine der beiden Lampen der Hauptarmaturen abgeschaltet werden können.

5

Revendications

1. Système d'éclairage pour un court de tennis, en particulier pour l'utilisation dans une salle de tennis (1), comprenant des blocs d'éclairage (6,7) comportant chacun au moins une lampe à décharge à haute pression (10) montée à l'intérieur d'un réflecteur (8), lesdits blocs d'éclairage étant disposés en deux rangées parallèles espacées l'une de l'autre dans le sens longitudinal le long d'un court, chaque rangée comprenant chacune quatre blocs d'éclairage (6,7), **caractérisé en ce que** les blocs sont asymétriques dans le sens longitudinal et **en ce que** les deux blocs primaires (6) de chaque rangée, respectivement, sont positionnés à une distance (P) mesurée horizontalement comprise entre 3,75 m et 4,75 m depuis le filet (3) et à une hauteur (HP) comprise entre 6 m et 8 m essentiellement au-dessus des lignes de côté du court (2), **en ce que** les deux blocs secondaires (7) de chaque rangée, respectivement, sont positionnés à une distance (S) mesurée horizontalement comprise entre 12 m et 13,5 m depuis le filet (3) et à une hauteur (HS) comprise entre 5 m et 6 m essentiellement au-dessus des lignes de côté du court (2), les blocs d'éclairage primaires de 400 watts (6) ayant chacun deux lampes à décharge à haute pression (10) et les blocs d'éclairage secondaires (7) ayant chacun une lampe à décharge à haute pression (10) du même genre, et **en ce que** les ouvertures de sortie de lumière des blocs se situent approximativement dans un plan horizontal dirigé vers le bas.

10
15
20
25
30
35
2. Système d'éclairage selon la revendication 1, **caractérisé en ce que** les blocs d'éclairage primaires (6) sont positionnés à une distance (P) mesurée horizontalement de 4,25 m depuis de filet et à une hauteur (HP) de 7 m essentiellement au-dessus des lignes de côté du court (2), **en ce que** quatre blocs d'éclairage secondaires sont positionnés à une distance (S) mesurée horizontalement de 12,75 m depuis le filet et à une hauteur (HS) de 5,5 m essentiellement au-dessus des lignes de côté du court (2).

40
45
50
3. Système d'éclairage selon la revendication 1 ou la revendication 2, **caractérisé en ce qu'il** est prévu des moyens de commutation au moyen desquels une des deux lampes dans les blocs primaires peut être éteinte.

55

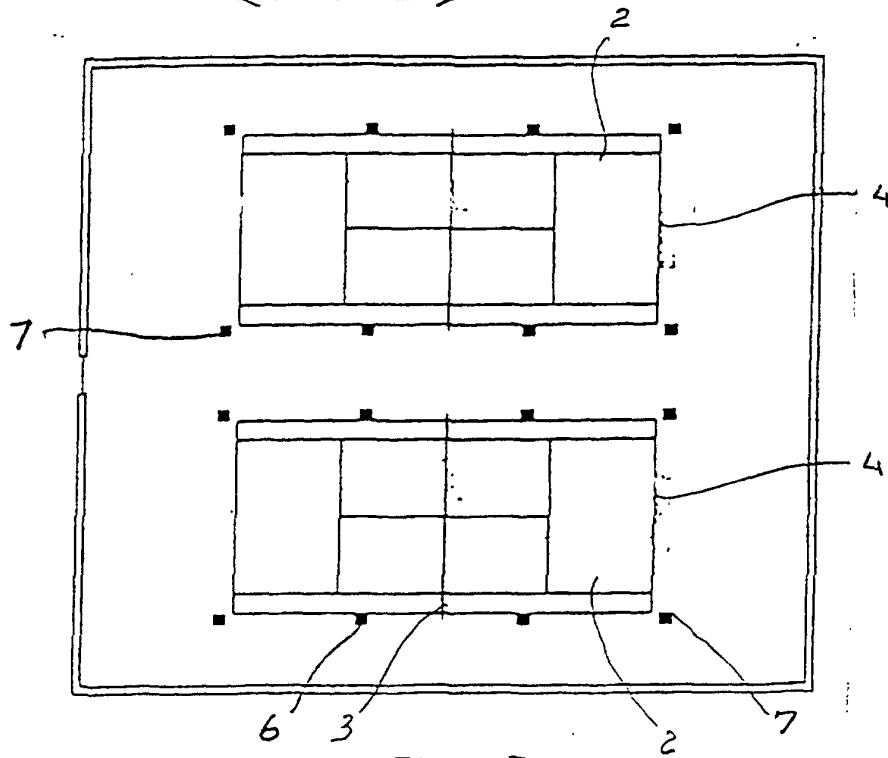
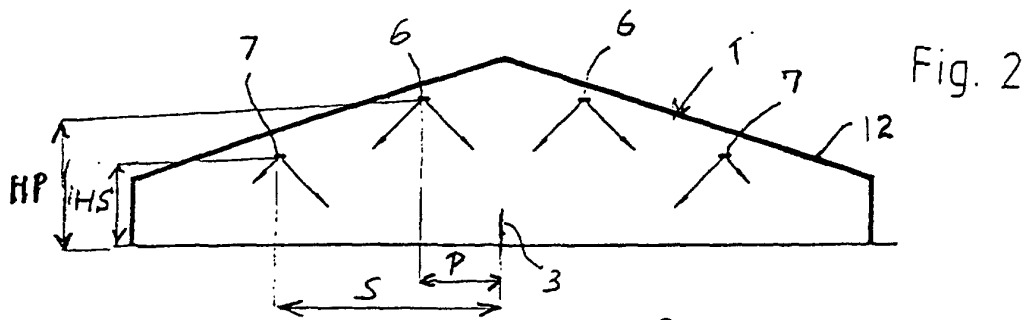
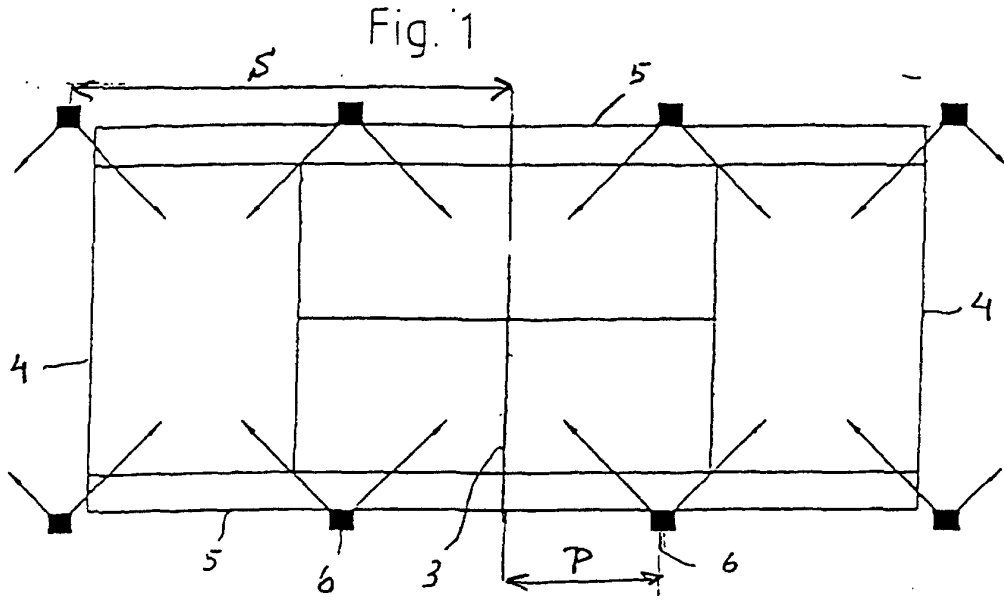

Fig. 3

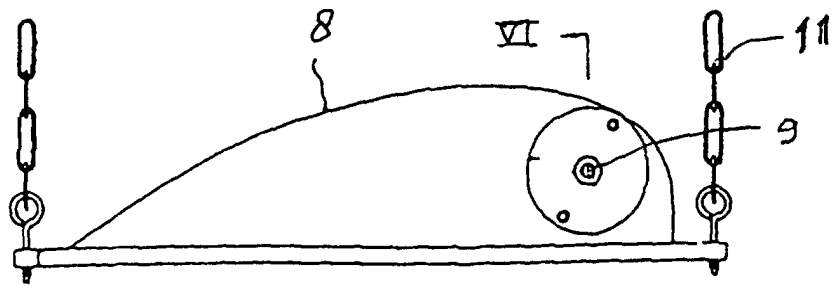

Fig. 4

VI

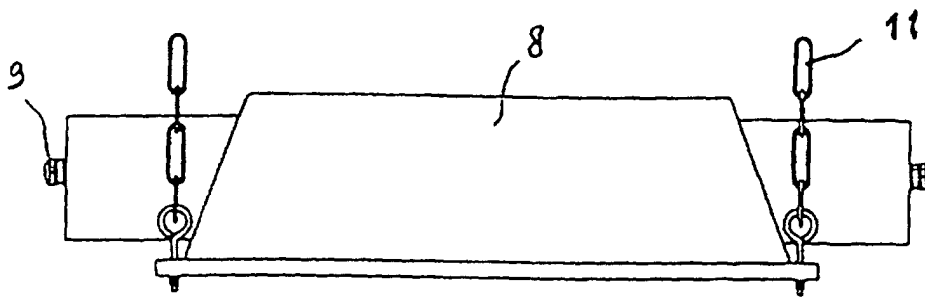

Fig. 5

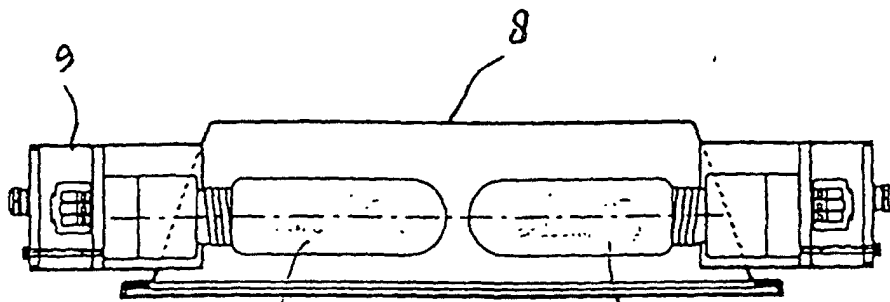

Fig. 6