



Europäisches Patentamt
European Patent Office
Office européen des brevets



(11) **EP 0 971 181 B1**

(12) **EUROPEAN PATENT SPECIFICATION**

(45) Date of publication and mention
of the grant of the patent:
25.08.2004 Bulletin 2004/35

(51) Int Cl.7: **F24H 9/20**

(21) Application number: **99500106.2**

(22) Date of filing: **23.06.1999**

(54) **A control system for heating boilers**

Kontrollsystem für Heizkessel

Système de contrôle pour chaudières

(84) Designated Contracting States:
**AT BE CH CY DE DK ES FI FR GB GR IE IT LI LU
MC NL PT SE**

(30) Priority: **07.07.1998 ES 9801427**

(43) Date of publication of application:
12.01.2000 Bulletin 2000/02

(73) Proprietor: **Sanchez Navarro, Alfredo
31500 Tudela (Navarra) (ES)**

(72) Inventor: **Sanchez Navarro, Alfredo
31500 Tudela (Navarra) (ES)**

(74) Representative: **Aragones Forner, Rafael Angel
Pastells & Aragones, S.L.
Pau Claris, 138
08009 Barcelona (ES)**

(56) References cited:
DE-A- 19 624 016 FR-A- 2 708 722

EP 0 971 181 B1

Note: Within nine months from the publication of the mention of the grant of the European patent, any person may give notice to the European Patent Office of opposition to the European patent granted. Notice of opposition shall be filed in a written reasoned statement. It shall not be deemed to have been filed until the opposition fee has been paid. (Art. 99(1) European Patent Convention).

Description

[0001] The present invention has as its object a control system for heating boilers.

[0002] The heating boilers specially contemplated by the present invention are of the type of those using liquid or gaseous fuels, feeding in the combustion air by means of using a blower or without using such a feeding means, and being apt to provide heating or both heating and sanitary hot water supply.

[0003] Conventionally in order to control and/or regulate the operation of the heating boilers the user has had to go to the place where the heating boiler is located in order to ascertain the boiler's condition and/or to modify its operating conditions through the controls provided for such a purpose.

[0004] More recently and in particular for the case of those boilers that are located outdoors there is the possibility of removing from the boiler a unit allowing to control and/or regulate the boiler from a given distance from it.

[0005] Those are nevertheless systems that limit to a great extent the installation possibilities thereby offering a very limited or null versatility and preventing the user from having a series of options in order to select one being best suited for the characteristics of each facility and to his or her preferences as for the control and/or regulation of the boiler.

[0006] Patent FR 2 708 722 of Bosch Siemens Hausgeraete consists in a panel for apparatus, particularly for heating boilers of hot water. This panel allows the control and regulation of the apparatus by the user positioned close or far of it, by means of a control and regulation unit. This panel comprises a fixed part coupled to the apparatus having a recess forming a housing. The control and regulation unit handled by user, may be coupled to the cited housing at the apparatus or separated providing a distant control.

[0007] The control system being the object of this invention obviates the above-mentioned drawbacks thereby allowing the user on the one hand to ascertain the boiler's condition and/or to modify its operating conditions by going to the location of the boiler itself, and on the other hand allowing the user to have configured as per the user's wishes in such a way that on the one hand the communication between the distant control unit and the boiler can be established through two wires or via radio waves, and on the other hand this distant control unit can be conceived as a simple control and regulation unit, as a unit allowing besides to display the temperature of the ambient where said unit is located, or as a unit allowing besides to regulate the operation of the boiler in order to be in a position to keep essentially constant the temperature of the room where the unit is located, to be in a position to programme the boiler's operating and stoppage periods, etc., all this by means of a very simple equipment and through operations that can be carried out in a quick and unmistakable

way by unskilled personnel.

[0008] According to what has been set forth above, the control system for heating boilers using liquid or gaseous fuels, wherein combustion air feeding is made using a blower or not, and are apt to provide heating or both heating and sanitary hot water supply, is characterized in that it comprises a series of electronic elements comprising: a fixed part that is fitted to the boiler, receives the electric supply, and has the different active components of the boiler to be regulated connected to it; a movable part that can be removably coupled to the fixed part and comprises at least one keyset and one display screen allowing to ascertain the several parameters defining the boiler's condition at all times and to enter the desired set points in order to regulate and control the boiler; an independent socket to which can be removably coupled the movable part when the latter is removed from the fixed part, both said elements, i.e. the movable part and the socket, forming when coupled together an ambient unit for the remote control and regulation of the heating boiler in question, said socket being provided with a electronic means allowing the above-mentioned ambient unit to bidirectionally communicate with the boiler; and a module provided with a electronic means allowing the fixed part of the boiler to bidirectionally communicate with the ambient unit, said module being apt to be coupled into the housing provided in the fixed part when the movable part is removed from said fixed part and is coupled to the socket thus forming the ambient unit; said arrangement allowing to regulate and control the heating boiler *in situ* from the boiler itself when the movable part is coupled to the fixed part, and from a distance when the movable part is coupled to the socket thus forming the ambient unit, and when the module is coupled to the fixed part.

[0009] According to the present invention, the socket of the ambient unit can incorporate a temperature probe allowing to besides display through the display screen of the ambient unit the temperature of the room where said unit is located; the electronic means apt to additionally form an ambient thermostat; a display screen for displaying information additional to that displayed on the movable part; a keyset, a display screen and the electronic means apt to form a programmable control and regulation ambient unit; a temperature probe to form a programmable control and regulation ambient unit with the possibility of displaying the temperature of the room where said ambient unit is located; and the electronic means apt to form a programmable ambient thermostat.

[0010] According to the invention the movable part can be coupled to an area of the boiler which is separated from the fixed part but is electrically connected to it, and which is besides easily accessible for the user.

[0011] The bidirectional communication between the module provided to be coupled to the fixed part of the boiler and the socket receiving the movable part thus forming the ambient unit can be established through two wires.

[0012] The bidirectional communication between the module provided to be coupled to the fixed part of the boiler and the socket receiving the movable part thus forming an ambient unit is also established via radio waves, the module and the socket incorporating in this case the corresponding antennas for the correct communication. The antenna of the boiler can be placed near said boiler instead of directly on it, and a series of repeaters can be arranged between the boiler and the ambient unit.

[0013] These and other characteristics will be best made apparent by the following detailed description whose understanding will be made easier by the accompanying two sheets of drawings showing a practical embodiment cited only by way of an example which does not limit the scope of the present invention.

[0014] In the drawings:

Fig. 1 is an elevational view of the system of the invention fitted to a boiler in order to carry out the control *in situ* at the boiler itself;

Fig. 2 is an elevational view of the movable part separated from the fixed part fitted to the boiler;

Fig. 3 is an elevational view illustrating the elements that remain fitted to the boiler, such as the fixed part and the module replacing the movable part after its having been separated from the fixed part;

Fig. 3a is an elevational view illustrating the elements forming the ambient unit with additional display screen and keyset allowing to use the programming function and acting as a distant control as per the system of the invention;

Fig. 3b is an elevational view illustrating the elements forming the ambient unit with additional display screen which acts as a distant control;

Fig. 3c is an elevational view illustrating the elements forming the ambient unit without additional keyset and display screen, acting as a distant control.

[0015] According to the drawings, the control system for heating boilers being the object of the present invention allows to control and regulate (not illustrated) heating boilers that use liquid or gaseous fuels, feed in the combustion air by means of using a blower or without using such a feeding means, and are apt to provide heating or both heating and sanitary hot water supply.

[0016] The control system of the present invention comprises a series of electronic elements that can be subdivided into those being fitted to the boiler in order to carry out the control and regulation of the boiler *in situ* at the boiler itself, and those forming a distant control allowing to remotely carry out said control and regulation and also being optionally programmable.

[0017] As has been said above, Fig. 1 illustrates the control system for heating boilers as per the present invention generally indicated at 1 which corresponds to the control system that is fitted to the boiler for the user

him- or herself to control and regulate said boiler *in situ*.

[0018] Arrangement 1 comprises a fixed part 2 that is integrally and hence permanently fitted to the boiler itself, said fixed part 2 receiving the supply from the mains or from an equivalent power supply, and having connected to it the different active components of the boiler (not illustrated) to be regulated, such as the burner, the circulators, etc. The fixed part 2 is provided with indicators 2a, 2b, 2c and 2d indicating, for example, if the boiler is in operation, if the flame is extinguished, if the pressure is the correct one, or if there is a trouble condition, respectively, said indicators possibly consisting in LEDs or the like.

[0019] Arrangement 1 comprises a movable part 3 which in a removably, couplably and extractably way can be plugged into the fixed part 2, said movable part 3 comprising several keysets 3a in a longitudinal half and a display screen 3b in the other longitudinal half, said keysets 3a of a longitudinal half allowing to regulate and control the boiler *in situ*, since they allow to ascertain the values of the boiler, and to enter the desired reference values and/or the limitations for entering said values. Said keysets 3a comprise, for example, a key 3a1 to ascertain the boiler pressure value, a key 3a2 to ascertain and/or modify the sanitary water temperature reference values, a key 3a3 to ascertain and/or modify the heating circuit temperature, two antagonistic keys 3a4 and 3a4' to increase or reduce the desired reference values, and a pushbutton 4 which depending on the number of times it is actuated instructs the boiler to operate in the sanitary hot water supply mode as illustrated at 4a, in the heating and sanitary hot water supply mode as illustrated at 4b, or in the standby mode as illustrated at 4c.

[0020] Display screen 3b of the left-hand half shows a scale 3b1 which depending on the actuated key, such as, for example, key 3a1, 3a2 or 3a3, shows in said scale a pressure in bars or a temperature in °C, respectively, while at the top side is symbolically shown 3b2, to what parameter type the scale 3b1 is referring to.

[0021] Fig. 2 illustrates the movable part 3 separated from the fixed part 2 fitted to the boiler, said separation being facilitated by means of grabbing recesses 5 which are facing each other and provided in the fixed part 2 (see Fig. 1).

[0022] Whereas Fig. 1 illustrates the system for the user to control and regulate the boiler *in situ*, Figs. 3 and 3a in combination illustrate the remote control and regulation of the boiler on the user's part. Fig. 3 illustrates moreover the control system for heating boilers as per the present invention comprising the fixed part 2 which remains fitted to the boiler itself PCC and from which has been separated the movable part 3, whereupon module 6 has been coupled in its place. As can be seen, the arrangement illustrated in Fig. 3 comprises the following elements: the fixed part 2 already described with reference to Fig. 1 and provided with indicators 2a, 2b, 2c and 2d, and the module 6 having been besides in-

corporated.

[0023] Fig. 3a illustrates moreover the movable part 3 already described with reference to Fig. 1, said movable part having been removed from the fixed part 2 and having been coupled to an independent socket 7. In the place having been vacated by the movable part 3 removed from the housing provided in the fixed part 2 has been coupled module 6 as has been illustrated (Fig. 3) and described. Independent socket 7 (Fig. 3a) comprises a keyset 7a, 7b, 7c, 7'b, 7'c and 7'd and a display screen 7'a, and can also incorporate a temperature probe to indicate the ambient temperature or to form with the adequate electronic means a programmable ambient thermostat. The ambient temperature is shown on the same scale 3b1 of the movable part 3 coupled to the socket 7. Both elements, i.e. the socket 7 and the movable part 3, coupled together as per the arrangement illustrated in Fig. 3a form a remotely programmable control and regulation ambient unit for the heating boiler, thereby forming a distant control MD in combination with the arrangement PCC illustrated in Fig. 3.

[0024] As has been indicated, Fig. 3 illustrates the arrangement that remains in the heating boiler PCC, comprising the fixed part 2 already described and the module 6 which is coupled to said fixed part 2 of the boiler when the movable part 3 has been removed. Module 6 has the same dimensions as the movable part 3 and is provided with an electronic means allowing the fixed part 2 of the boiler to communicate with the ambient unit or distant control MD illustrated in Fig. 3a.

[0025] The assembly of the arrangements PCC of Fig. 3 and MD of Fig. 3a allows to remotely regulate and control the heating boiler as per the user's wishes thereby programming the operation of the heating boiler by means of the controls 7'b to activate the programming function, 7'c to select the day of the week, and 7'd to set the clock time, and by means of the keyset 7a, 7b and 7c to enter the corresponding programme, this latter being displayed through the display screen 7'a.

[0026] Figs. 3 and 3b illustrate two arrangements of another distant control similar to those of Figs. 3 and 3a defining an assembly comprising the arrangement PCC illustrated in Fig. 3 and the ambient unit or distant control MD illustrated in Fig. 3b. The arrangement PCC remaining in the boiler and corresponding exactly to that illustrated in Fig. 3 consists of the fixed part 2 and the module 6 coupled to it. The arrangement of Fig. 3b corresponds on its part to an ambient unit or distant control MD comprising and independent socket 7' similar to but simpler than socket 7 of Fig. 3a, said socket 7' incorporating a display screen 7'a which can display faulty conditions of the system similar to those displayed by means of LEDs 2b, 2c and 2d of the fixed part 2. The same movable part 3 illustrated in Figs. 1 and 3a is coupled to said socket 7'.

[0027] In one aspect of the present invention, the socket of ambient unit MD can be a programmable distant control that can comprise an ambient thermostat such as that illustrated at 7, can be programmable with

out an ambient thermostat, or can be a simple distant control comprising an ambient thermostat. According to the invention and as illustrated in Fig. 3c, socket 7" can have no keyset and no display screen while acting in combination with arrangement PCC of Fig. 3.

[0028] In another aspect of the invention, the movable part 3 can be directly coupled to the fixed part 2 of the boiler, as illustrated in Fig. 1, or to an area of the boiler which is separated from the fixed part 2 but electrically connected to it, in order to facilitate the access for the user.

[0029] The communication between module 6 which is coupled to the fixed part 2 of the boiler thus forming that part which remains in the boiler PCC, and the socket 7, 7', 7" of the ambient unit or distant control MD, is a bidirectional communication established via radio waves or by means of two electric wires, for which purpose the module and the socket incorporate the corresponding antennas for a correct communication in the first case, and a series of repeaters can be arranged between them in order to improve said communication. The antenna of the boiler can on its side be placed directly on or near said boiler in order to eliminate possible interferences.

[0030] In an aspect of the system of the invention the reference value VC (see Fig. 2) for any chosen service is indicated by a blinking or intermittent light, whereas the real value VR is indicated by means of a solid display column.

Claims

1. A control system for heating boilers using liquid or gaseous fuels, feeding in the combustion air by means of using a blower or without using such a feeding means, being apt to provide heating or both heating and sanitary hot water supply, and having a control panel assembled at the heating boiler comprising a fixed part having a housing in which is coupled a control and regulation unit; **characterized in that** it comprises a series of electronic elements comprising:

a fixed part (2), having a housing, is fitted to the boiler, receives the electric supply, and has the different active components of the boiler to be regulated connected to it;

a movable part (3), forming the control and regulation unit, that can be removably coupled to the fixed part (2) and comprises at least one keyset (3a) and one display screen (3b) allowing to ascertain the several parameters defining the boiler's condition at all times and to enter the desired reference values (VC) in order to regulate and control the boiler;

an independent socket (7, 7', 7") to which can be removably coupled the movable part (3)

when the latter is removed from the housing of the fixed part (2), both said elements, i.e. the movable part (3) and the socket (7, 7', 7''), forming when coupled together an ambient unit (MD) for the remote control and regulation of the heating boiler in question, said socket (7, 7', 7'') being provided with a electronic means allowing the above-mentioned ambient unit (MD) to bidirectionally communicate with the boiler;

and a module (6) provided with a electronic means allowing the fixed part (2) of the boiler to bidirectionally communicate with the ambient unit (MD), said module being apt to be coupled into the housing provided in the fixed part (2) when the movable part (3) is removed from said fixed part (2) and is coupled to the socket (7, 7', 7'') thus forming the ambient unit (MD);

said arrangement allowing to regulate and control the heating boiler *in situ* from the boiler itself when the movable part (3) is coupled to the housing of the fixed part (2), and from a distance when the movable part (3) is coupled to the socket (7, 7', 7'') forming the ambient unit (MD), and the module (6) is coupled to the fixed part (2).

2. A control system for heating boilers as per claim 1, **characterized in that** the socket (7) of the ambient unit incorporates a temperature probe allowing to besides display through the display screen (7a) of the ambient unit (MD) the temperature of the room where said unit is located.
3. A system as per claim 2, **characterized in that** the socket (7) of the ambient unit (MD) incorporates besides the electronic means apt to additionally form an ambient thermostat.
4. A system as per claims 1, 2 or 3, **characterized in that** the socket (7, 7') of the ambient unit (MD) is provided with a display screen (7'a) for displaying informations additional to that displayed on the movable part (3).
5. A system as per claim 1, **characterized in that** the socket (7) of the ambient unit (MD) incorporates besides a keyset (7a, 7b, 7c, 7'b, 7'c, 7'd), a display screen (7'a) and the electronic means apt to form a programmable control and regulation ambient unit (MD).
6. A system as per claim 5, **characterized in that** it includes besides a temperature probe to form a programmable control and regulation ambient unit (MD) with the possibility of displaying the temperature of the room where said ambient unit (MD) is located.

7. A system as per claim 6, **characterized in that** the socket (7) of the ambient unit incorporates besides the electronic means apt to additionally form a programmable ambient thermostat.
8. A control system for heating boilers as per the preceding claims, **characterized in that** the movable part (3) is coupled to an area of the boiler which is separated from the housing of the fixed part (2) but is electrically connected to it, and which is besides easily accessible for the user.
9. A system as per the preceding claims, **characterized in that** the bidirectional communication between the module (6) provided to be coupled to the housing of the fixed part (2) of the boiler and the socket (7, 7', 7'') receiving the movable part thus forming the ambient unit is established through two wires.
10. A control system for heating boilers as per the preceding claims, **characterized in that** the bidirectional communication between the module (6) provided to be coupled to the housing of the fixed part (2) of the boiler and the socket (7, 7', 7'') receiving the movable part (3) thus forming the ambient unit (MD) is established via radio waves, the module (6) and the socket (7, 7', 7'') incorporating in this case the corresponding antennas for the correct communication.
11. A control system for heating boilers as per claim 10, **characterized in that** the antenna of the boiler can be placed near said boiler instead of directly on it.
12. A control system for heating boilers as per claims 10 and 11, **characterized in that** it comprises the placing of a series of repeaters arranged between the boiler and the ambient unit (MD).
13. A control system for heating boilers as per claims 1 to 7, **characterized in that** the display screen (3b) of the movable part (3) can display the different variables characterizing the operating conditions of the boiler (temperatures (3a3) and pressure (3a1)), as well as the ambient temperature, on a graduated scale (3b1) whose numerical values defining its amplitude are variable depending on the displayed variable, after having actuated the key corresponding to each variable.
14. A control system for heating boilers as per claim 13, **characterized in that** two values can be displayed at the same time on the graduated scale (3b1), said values being on the one hand the real value (VR) of the selected variable, displayed as a solid display column, and on the other hand the reference values or values (VC) of the same variable, displayed

in form of one or two segments of intermittent light.

Patentansprüche

1. Steuersystem für Heizungskessel die mit flüssigen bzw. gasförmigen Brennstoffen beheizt werden, mit Verbrennungsluft durch Einsatz eines Gebläses bzw. ohne den Einsatz eines solchen Beschikungsmittels beschickt werden, als Heizungskessel oder als Heizungs- und Warmwasserkessel betrieben werden können und ein Steuerfeld haben, das auf dem Heizungskessel angebracht ist und einen ortsfesten Teil umfaßt der eine Aufnahme hat wo die Steuer- und Regeleinheit gekoppelt ist; **dadurch gekennzeichnet, daß** es eine Reihe elektronischer Bestandteile umfaßt, die folgendes umfassen:

einen ortsfesten Teil (2) der eine Aufnahme hat, auf dem Kessel angebracht ist, die Stromversorgung einnimmt und mit den verschiedenen Aktivbestandteilen des zu regelnden Kessels verbunden ist;

einen beweglichen Teil (3) der die Steuer- und Regeleinheit bildet, zum ortsfesten Teil (2) trennbar gekoppelt werden kann und mindestens eine Tastatur (3a) und einen Anzeigebildschirm (3b) umfaßt, die es erlauben, die verschiedenen den Betriebszustand des Kessels definierenden Parameter zu jeder Zeit festzustellen und die gewünschten Sollwerte (VC) zwecks Regelung und Steuerung des Kessels einzugeben;

einen unabhängigen Sockel (7, 7', 7'') zu welchem der bewegliche Teil (3) nach seiner Herausnahme aus der Aufnahme des ortsfesten Teils (2) trennbar gekoppelt werden kann, wobei beide obengenannten Bestandteile, d.h. der bewegliche Teil (3) und der Sockel (7, 7', 7''), nach ihrer Zusammenkopplung eine Raumeinheit (MD) zur Fernsteuerung und -regelung des in Frage kommenden Kessels bilden, wobei der obengenannte Sockel (7, 7', 7'') mit einer Elektronik versehen ist, die die gegenseitige Verbindung der obengenannten Raumeinheit (MD) mit dem Kessel erlaubt;

und einen Baustein (6) der mit einer Elektronik versehen ist, die die gegenseitige Verbindung des ortsfesten Teils (2) des Kessels mit der Raumeinheit (MD) erlaubt, wobei der obengenannte Baustein nach der Herausnahme des beweglichen Teils (3) aus dem obengenannten ortsfesten Teil (2) und nach seiner Kopplung zum Sockel (7, 7', 7'') unter Bildung der Raumeinheit (MD) in die Aufnahme des ortsfesten Teils (2) koplebar ist;

wobei die obengenannte Anordnung es erlaubt, bei in der Aufnahme des ortsfesten Teils (2) gekoppeltem beweglichem Teil (3) aus dem eigentlichen Kessel den Heizungskessel *in situ* zu regeln und zu steuern, und bei zum Sockel (7, 7', 7'') unter Bildung der Raumeinheit (MD) gekoppletem beweglichem Teil (3) und bei zum ortsfesten Teil (2) gekoppletem Baustein (6) den Heizungskessel fernzuregeln und -zusteuern.

2. Steuersystem für Heizungskessel nach Anspruch 1, **dadurch gekennzeichnet, daß** der Sockel (7) der Raumeinheit einen Temperaturfühler umfaßt der es erlaubt, auf dem Anzeigebildschirm (7a) der Raumeinheit (MD) die Temperatur des Raums wo sich die obengenannte Raumeinheit befindet zusätzlich anzuzeigen.
3. System nach Anspruch 2, **dadurch gekennzeichnet, daß** der Sockel (7) der Raumeinheit (MD) ausserdem die zur zusätzlichen Bildung eines Raumthermostats geeignete Elektronik umfaßt.
4. System nach Anspruch 1, 2 bzw. 3, **dadurch gekennzeichnet, daß** der Sockel (7, 7') der Raumeinheit (MD) mit einem Anzeigebildschirm (7'a) zur Anzeige von über die beim beweglichen Teil (3) angezeigte Information hinausgehenden Informationen versehen ist.
5. System nach Anspruch 1, **dadurch gekennzeichnet, daß** der Sockel (7) der Raumeinheit (MD) zusätzlich eine Tastatur (7a, 7b, 7c, 7'b, 7'c, 7'd), einen Anzeigebildschirm (7'a) und die zur Bildung einer zur programmierbaren Steuerung und Regelung einsetzbaren Raumeinheit (MD) geeignete Elektronik umfaßt.
6. System nach Anspruch 5, **dadurch gekennzeichnet, daß** es ausserdem einen eine zur programmierbaren Steuerung und Regelung einsetzbare Raumeinheit (MD) bildenden Temperaturfühler umfaßt, der die Anzeige der Temperatur des Raums wo sich die obengenannte Raumeinheit (MD) befindet erlaubt.
7. System nach Anspruch 6, **dadurch gekennzeichnet, daß** der Sockel (7) der Raumeinheit ausserdem die zur zusätzlichen Bildung eines programmierbaren Raumthermostats geeignete Elektronik umfaßt.
8. Steuersystem für Heizungskessel nach den vorhergehenden Ansprüchen, **dadurch gekennzeichnet, daß** der bewegliche Teil (3) in einem von der Aufnahme des ortsfesten Teils (2) getrennten aber mit ihr elektrisch verbundenen, dem Benutzer leicht zugänglichen Bereich des Kessels gekoppelt wird.

9. System nach den vorhergehenden Ansprüchen, **dadurch gekennzeichnet, daß** die gegenseitige Verbindung zwischen dem zur Aufnahme des ortsfesten Teils (2) des Kessels zu koppelnde Baustein (6) und dem den beweglichen Teil unter Bildung der Raumeinheit aufnehmenden Sockel (7, 7', 7'') durch zwei Leitungsdrähte hergestellt wird. 5
10. Steuersystem für Heizungskessel nach den vorhergehenden Ansprüchen, **dadurch gekennzeichnet, daß** die gegenseitige Verbindung zwischen dem zur Aufnahme des ortsfesten Teils (2) des Kessels zu koppelnde Baustein (6) und dem den beweglichen Teil (3) unter Bildung der Raumeinheit (MD) aufnehmenden Sockel (7, 7', 7'') als Funkverbindung hergestellt wird, wobei der Baustein (6) und der Sockel (7, 7', 7'') in diesem Fall die entsprechende Antennen zur richtigen Verbindung umfassen. 10
11. Steuersystem für Heizungskessel nach Anspruch 10, **dadurch gekennzeichnet, daß** die Kesselantenne in der Nähe des Kessels an Stelle von direkt auf dem Kessel untergebracht werden kann. 20
12. Steuersystem für Heizungskessel nach Anspruch 10 und 11, **dadurch gekennzeichnet, daß** es die Aufstellung einer Reihe von zwischen dem Kessel und der Raumeinheit (MD) angeordneten Zwischenverstärkern umfaßt. 25
13. Steuersystem für Heizungskessel nach Anspruch 1 bis 7, **dadurch gekennzeichnet, daß** die verschiedenen den Betriebszustand des Kessels kennzeichnenden Variablen (Temperaturen (3a3) und Druck (3a1)) sowie die Raumtemperatur auf dem Anzeigebildschirm (3b) des beweglichen Teils (3) auf einer Messkala (3b1) angezeigt werden können, wobei die die Messkalenamplitude definierenden Messkalenwerte in Abhängigkeit von der nach Betätigung der jeweils entsprechenden Taste gezeigten Variable veränderbar sind. 30
14. Steuersystem für Heizungskessel nach Anspruch 13, **dadurch gekennzeichnet, daß** zwei sind die Werte die auf der Messkala (3b1) gleichzeitig gezeigt werden können, und zwar einerseits der als ununterbrochener Balken gezeigte Istwert der ausgewählten Variable, und andererseits der bzw. die derselben Variable zugehörte(n), als ein bzw. zwei intermittierend aufleuchtendes bzw. aufleuchtenden Segment bzw. Segmente gezeigte(n) Sollwert bzw. -werte (VC). 35

Revendications 55

1. Système de contrôle pour les chaudières de chauffage qui utilisent des combustibles liquides ou ga-

zeux, l'apport d'air de combustion dans celles-ci s'effectuant avec ou sans ventilateur, ces chaudières étant prévues pour fournir le service de chauffage ou celui combiné de chauffage et eau chaude sanitaire et étant équipées d'un panneau de contrôle monté sur la chaudière de chauffage et comportant une partie fixe où se trouve un logement dans lequel est accouplé un groupe de contrôle et réglage, ce système de contrôle étant **caractérisé par le fait qu'il** comporte une série d'éléments électroniques comprenant les éléments suivants :

une partie fixe (2) ayant un logement, qui est montée sur la chaudière, reçoit l'alimentation électrique, avec la connexion à celle-ci des différents composant actifs de la chaudière objet du réglage ;

une partie mobile (3) qui constitue le groupe de contrôle et réglage, peut être accouplée de manière amovible à la partie fixe (2) et comporte au moins un clavier (3a) et un écran d'affichage (3b) qui permettent de connaître les différents paramètres définissant la situation de la chaudière à tout moment et d'introduire les valeurs de consigne (VC) désirées, afin de régler et contrôler la chaudière ;

un socle indépendant (7, 7', 7'') auquel on peut accoupler de manière amovible la partie mobile (3) lorsque cette dernière est retirée du logement de la partie fixe (2), ces deux éléments accouplés, c'est-à-dire la partie mobile (3) et le socle (7, 7', 7'') formant une unité ambiante (MD) de contrôle et réglage à distance de la chaudière de chauffage en question, dont le socle (7, 7', 7'') est muni d'une partie électronique permettant une communication bilatérale avec la chaudière de l'unité ambiante (MD) déjà mentionnée ;

et un module (6) muni d'une partie électronique permettant la communication bidirectionnelle de la partie fixe (2) de la chaudière avec l'unité ambiante (MD), qui peut être accouplée au logement de la partie fixe (2) lorsqu'on retire la partie mobile (3) de cette partie fixe (2) et qui est accouplée au socle (7, 7', 7'') de manière à former l'unité ambiante (MD) ;

dont la disposition permet de régler et contrôler la chaudière de chauffage sur place depuis la chaudière même, la partie mobile (3) étant accouplée au logement de la partie fixe (2), et la partie mobile (3) étant accouplée à distance au socle (7, 7', 7'') de manière à former l'unité ambiante (MD) et le module (6) étant accouplé à la partie fixe (2).

2. Système de contrôle pour chaudières de chauffage conformément à la revendication 1, **caractérisé par le fait que** le socle (7) de l'unité ambiante com-

- porte un capteur de température grâce auquel on peut afficher en outre à l'écran d'affichage (7a) de l'unité ambiante (MD) la température du local où se trouve cette unité.
3. Système conforme à la revendication 2, **caractérisé par le fait que** le socle (7) de l'unité ambiante (MD) comporte en outre une partie électronique permettant de constituer en plus un thermostat d'ambiance. 5
 4. Système conforme aux revendications 1, 2 ou 3, **caractérisé par le fait que** le socle (7, 7') de l'unité ambiante (MD) est muni d'un écran affichant (7'a) des informations complétant celles affichées sur la partie mobile. 10
 5. Système conforme à la revendication 1, **caractérisé par le fait que** le socle (7) de l'unité ambiante (MD) comporte en outre un clavier (7a, 7b, 7c, 7'b, 7'c, 7'd), un écran d'affichage (7'a) et une partie électronique permettant de former une unité ambiante (MD) de contrôle et réglage programmable. 15
 6. Système conforme à la revendication 5, **caractérisé par le fait qu'il** comprend en outre un capteur de température permettant de former une unité ambiante (MD) de contrôle et réglage programmable, avec la possibilité d'afficher la température du local où se trouve cette unité ambiante (MD). 20
 7. Système conforme à la revendication 6, **caractérisé par le fait que** le socle (7) de l'unité ambiante comporte en outre une partie électronique permettant de former de plus un thermostat d'ambiance programmable. 25
 8. Système de contrôle pour chaudières de chauffage conforme aux revendications précédentes, **caractérisé par le fait que** la partie mobile (3) s'accouple à une partie de la chaudière séparée mais électriquement connectée au logement de la partie fixe (2), d'accès facile pour l'utilisateur. 30
 9. Système conforme aux revendications précédentes, **caractérisé par le fait que** la communication bidirectionnelle entre le module (6) qui s'accouple au logement de la partie fixe (2) de la chaudière et le socle (7, 7', 7'') qui reçoit la partie mobile formant l'unité ambiante se fait grâce à deux fils. 35
 10. Système de contrôle pour chaudières de chauffage conforme aux revendications précédentes, **caractérisé par le fait que** la communication bidirectionnelle entre le module (6) qui s'accouple au logement de la partie fixe (2) de la chaudière et le socle (7, 7', 7'') qui reçoit la partie mobile (3) formant l'unité ambiante (MD) se fait par radio, et que dans ce cas 40
 11. Système de contrôle pour chaudières de chauffage, conforme à la revendication 10, **caractérisé par le fait que** l'antenne de la chaudière peut être placée à côté de celle-ci au lieu d'être placée directement sur celle-ci. 45
 12. Système de contrôle pour chaudières de chauffage conformément aux revendications 10 et 11, **caractérisé par le fait qu'il** comporte la pose d'une série de répéteurs placés entre la chaudière et l'unité ambiante (MD). 50
 13. Système de contrôle pour chaudières de chauffage conformément aux revendications 1 à 7, **caractérisé par le fait que** sur l'écran d'affichage (3b) de la partie mobile (3) peuvent s'afficher les différentes variables qui caractérisent l'état de la chaudière (températures (3a3) et pression (3a1), ainsi que la température ambiante, sur une échelle graduée (3b1), dont les valeurs numériques définissant leur ampleur sont variables en fonction de la variable affichée, après actionnement de la touche correspondant à chaque variable. ' 55
 14. Système de contrôle pour chaudières de chauffage conformément à la revendication 13, **caractérisé par le fait que** sur l'échelle graduée (3b1) deux valeurs peuvent s'afficher simultanément, d'un côté la valeur réelle (VR) de la variable sélectionnée, sous forme d'une colonne continue, et de l'autre la valeur ou les valeurs de consigne (VC) de la même variable sous forme d'un ou deux segments à allumage intermittent.

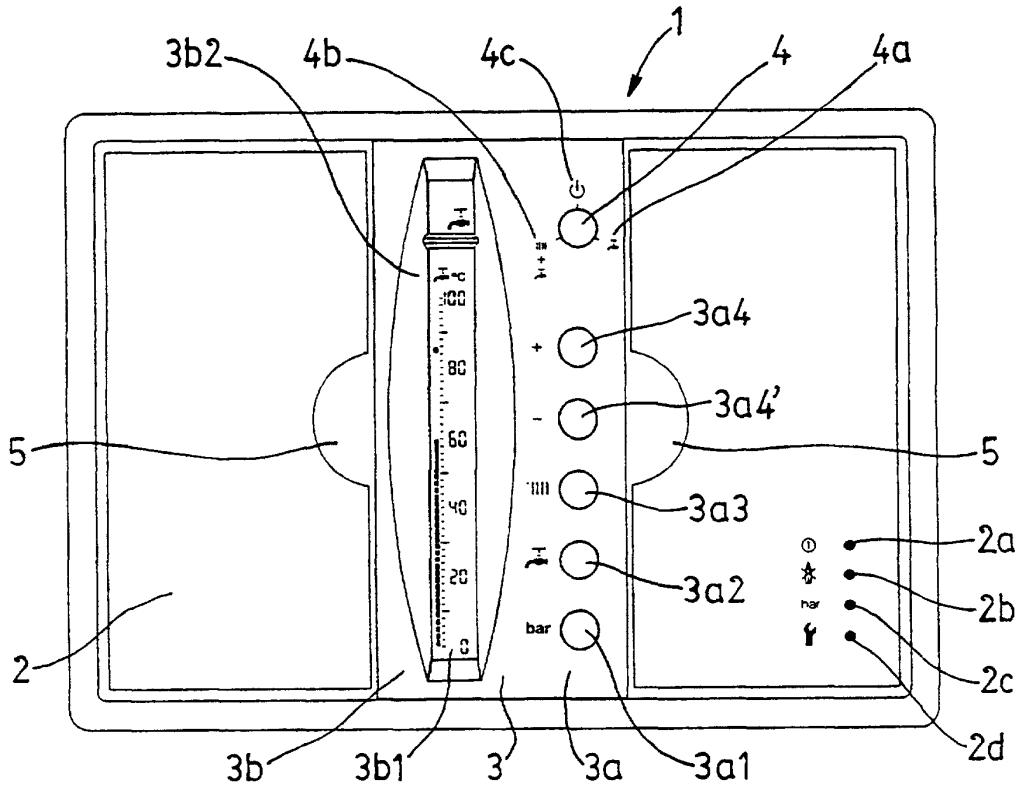

Fig. 1

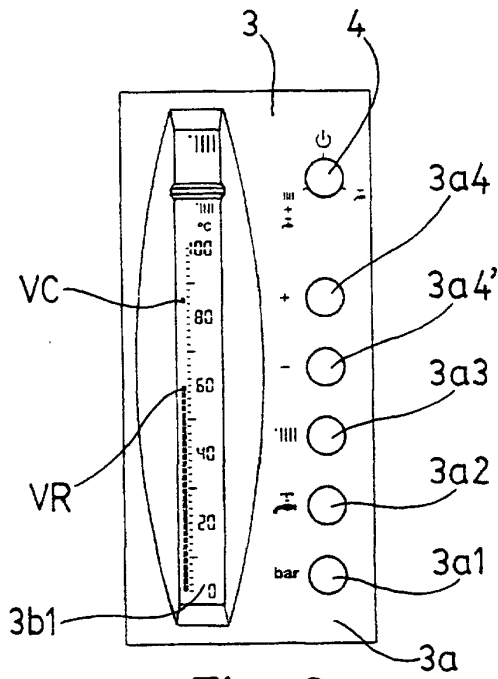

Fig. 2

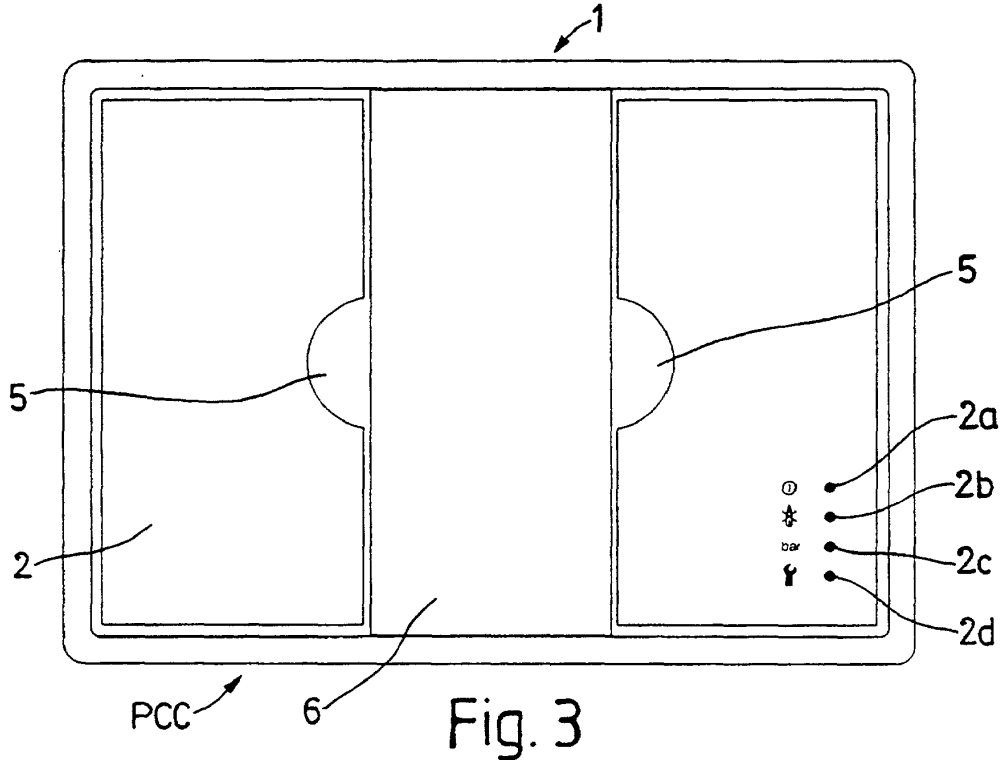

Fig. 3

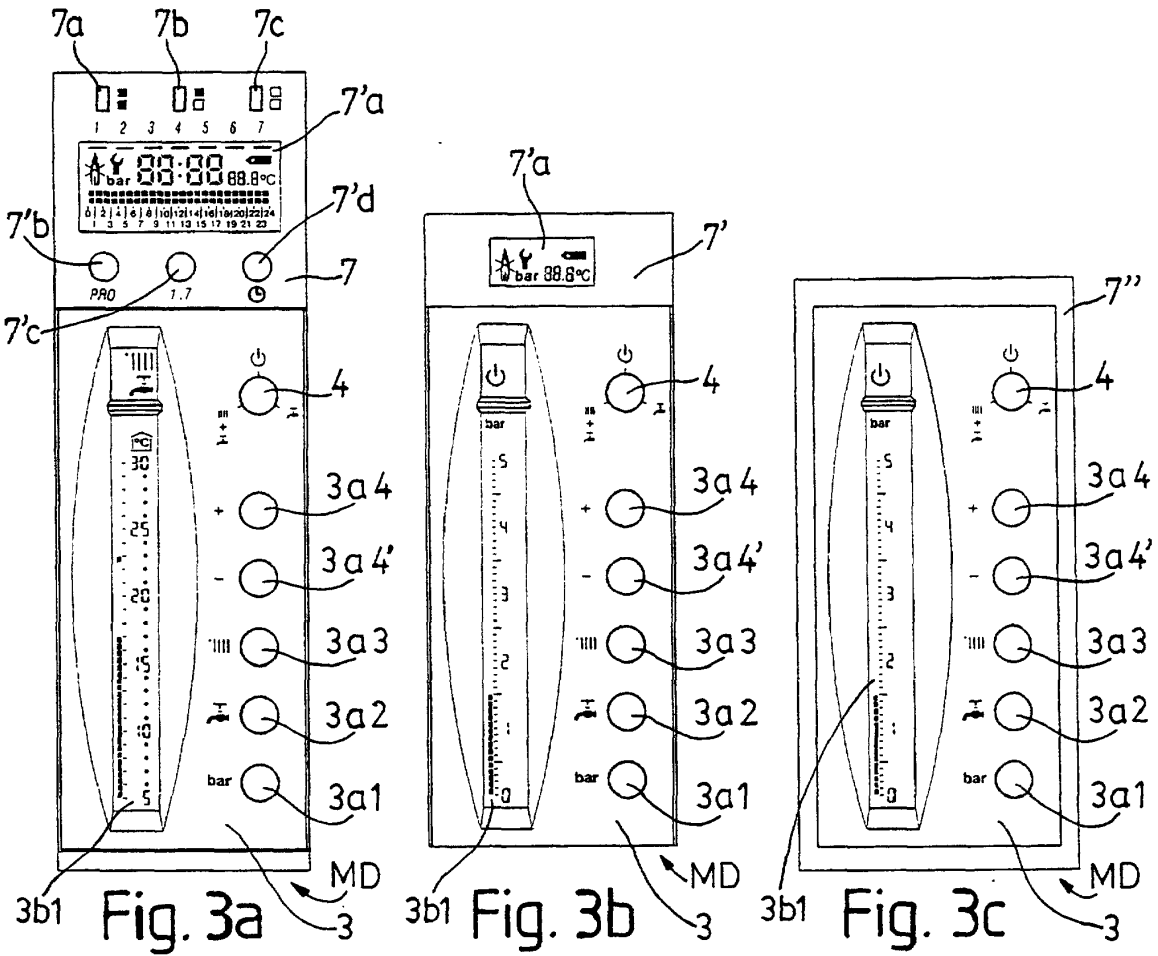

Fig. 3a

Fig. 3b

Fig. 3c