



Europäisches Patentamt  
 European Patent Office  
 Office européen des brevets



(11) **EP 0 974 284 A1**

(12) **EUROPEAN PATENT APPLICATION**

(43) Date of publication:  
**26.01.2000 Bulletin 2000/04**

(51) Int. Cl.<sup>7</sup>: **A44C 5/12**, A44C 7/00,  
 A44C 9/00

(21) Application number: **99106859.4**

(22) Date of filing: **07.04.1999**

(84) Designated Contracting States:  
**AT BE CH CY DE DK ES FI FR GB GR IE IT LI LU  
 MC NL PT SE**  
 Designated Extension States:  
**AL LT LV MK RO SI**

(72) Inventor: **Pasavento, Marino**  
**36100 Vicenza VI (IT)**

(74) Representative:  
**La Ciura, Salvatore**  
**Via Francesco Sforza 3**  
**20122 Milano (IT)**

(30) Priority: **20.07.1998 IT VI980060**

(71) Applicant: **PESAVENTO S.r.l.**  
**36100 Vicenza VI (IT)**

(54) **Piece of jewellery, in particular bracelet, with improved spring locking device**

(57) A jewel comprising two arms being hinged at one of their ends, and spring means for tightening said arms, an end of said spring means being applied to one of said arms and the other end of said spring means engaging the second arm, characterized in that the

ends of said spring means are placed respectively inside one and the other arm, from which they get out at the hinge area.

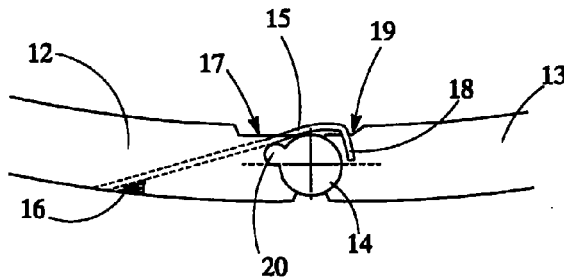

Fig. 3

**EP 0 974 284 A1**

## Description

**[0001]** The present invention provides a piece of jewellery, such as a bracelet, a necklace or the like, consisting of two hinged arms or bars and spring means keeping the jewels in their locking position.

**[0002]** The jewel is characterized by the particular configuration of these spring locking devices, which, besides being aesthetically preferable to the ones known in the art, have the considerable advantage of preventing the skin from being pinched or pricked when locking the jewel.

**[0003]** More particularly, the bracelet of the invention is provided with a spring member which, at one of its ends, is welded to the inside of one of the bars forming the bracelet, gets out of this bar a little before the hinge area and has the second end bent inwards and getting into a corresponding opening in the second bar.

**[0004]** In the hinge area a cam member is integral with one of the bars, said cam member having such a configuration that, when the bracelet is opened, the spring acts on this cam member to return the bracelet into its locking position.

**[0005]** The assembly has such dimensions that the bent end portion of the spring acts as a stop means to limit the excessive opening of the arms forming the jewel.

**[0006]** Several kinds of jewels are known, in particular bracelets, necklaces, earrings or the like, comprising two folded arms or bars being hinged with each other at one end and being subject to the action of elastic means which keep them in their locking position, by tightening each against the other.

**[0007]** The use of spring devices provides several advantages both for the manufacturer, who no longer needs clips or the like which imply functional problems and higher production costs, and for the user, for whom the jewel is much more practical since, to put it on or off, it is sufficient to open wide the arms which then are closed again due to the force from the spring.

**[0008]** A known embodiment, shown in figure 1, utilizes a spring located inside the arms, which are indicated with numerals 1 and 2 in figure 1.

**[0009]** The arms are joined by a hinge 3 and a spring 4 is placed inside, said spring 4 tightening the arms each against the other.

**[0010]** A further known embodiment is provided with a spring member, an end of which is fastened, by means of rivets or the like, to the outer surface of one of the arms.

**[0011]** This spring member is then passed inside the bar, from which it gets out near the hinge to contact the second arm.

**[0012]** However, both known embodiments have several drawbacks.

**[0013]** The embodiment with the inner spring has the drawback that the two hinged arm ends tend to pinch the user's skin when the jewel is closed and they do not

keep opened wide when the user opens the jewel to put it on.

**[0014]** The second embodiment, with the spring getting out of one of the bars to contact the second arm, is considerably complicated to assemble and it also has some drawbacks since, when the arms are opened, the spring end tends to move slightly away from the arm on which it rests, with the risk, when the jewel gets closed, of pinching or pricking the user's skin.

**[0015]** The present invention falls within this field by providing a jewel with improved spring locking devices which can overcome the above mentioned drawbacks.

**[0016]** In particular, according to the invention, a spring is used an end of which is welded inside one of the bars and gets out a little before the hinge, up to the other arm where the second, bent spring end gets into an opening in the arm wall.

**[0017]** In the hinge area a cam is provided which engages the spring whereby, when opening the arms, the spring, by acting on the cam, tends to close the jewel.

**[0018]** These and other features of the present invention will become more apparent from the following detailed description, provided by way of non restrictive example, with reference to the accompanying drawings in which:

- figure 2 schematically shows a bracelet according to the invention;
- figure 3 shows a detail of a partial cross-sectional view of the closed bracelet;
- figure 4 shows a detail of a partial cross-sectional view of the opened bracelet;
- figure 5 is a schematic perspective view of the two disassembled bars forming the bracelet.

**[0019]** With reference to figure 2, numeral 10 shows a jewel, specifically a bracelet, comprising a pair of arms or bars 12 and 13 joined by a hinge 14.

**[0020]** According to the invention, a spring member 15 acts on the arms 12 and 13 to keep them in their locking position.

**[0021]** In particular an end of the spring member 15 is welded at numeral 16 to the inside of the two bars, it goes on inside the bar for a certain length and it gets out of the bar at an opening 17 near the hinge 14, to pass on said hinge and contact the second arm 13.

**[0022]** Here the spring end 18 is bent inwards and it gets into a corresponding opening 19 in the wall of the bar 13.

**[0023]** A cam member 20 being engaged by the spring 15 is integral with the bar 13.

**[0024]** The cam member 20 has an outline with two oppositely sloping inclinations on which the the spring acts respectively in the opening and closing position, so that the force from the spring tends to keep the bracelet respectively open or closed.

**[0025]** When the arms 12 and 13 are rotated to open

or close the bracelet, the cam lifts the spring during the first motion part, until the dead centre is passed, after which the force from the spring helps the arm motion to bring the bracelet in the open or closed position.

**[0026]** Substantially, owing to the cam 20, the spring tends to keep the bracelet in the opening or closing position by opposing the rotation of the arms 12 and 13 until the dead centre is passed, after which the spring opposes the motion in the opposite direction.

**[0027]** This configuration has several advantages with respect to the known embodiments, both from an aesthetic point of view, since only a part of the spring gets out of the arms, and only in the hinge area, and because the risk of skin pinching is considerably reduced, since the spring no longer moves away from the bracelet with the risk of pinching the user's skin when closing the bracelet.

**[0028]** The invention has been described with specific reference to a bracelet, but clearly the same solution may be effectively applied to other jewels such as necklaces, ear-rings and the like. The same invention may then be carried out in several different ways.

**[0029]** For instance, with jewels comprising a plurality of bars placed side by side a single pin may be provided which joins several bars, one or more of them receiving the springs which act on cams being integral with the pin and the second bar.

**[0030]** Likewise, the dimensions, as well as the materials being used, may change according to the needs.

### Claims

1. A jewel comprising two arms being hinged at one of their ends, and spring means for tightening said arms, an end of said spring means being attached to one of said arms and the other end of said spring means engaging the second arm, characterized in that the ends of said spring means are placed respectively inside one and the other arm, from which they get out at the hinge area.
2. The jewel of claim 1, characterized in that said spring means comprise a spring member an end of which is welded inside one of said arms, said spring member getting out of said arm at the hinge area and going beyond said hinge, the second end of said spring member being bent and getting into a corresponding opening in the second arm.
3. The jewel of claim 1 or 2, characterized in that it is provided with a cam member being integral with one of said arms, said cam member engaging said spring member to deform it when rotating the arms to open or close the jewel, the outline of said cam member having two opposedly sloping sides, whereby, when the bracelet is in the opening or closing position, said spring engages either side, keeping said arms in said opening or closing posi-

tion.

4. A jewel being characterized in that it comprises:
  - a pair of hinged arms;
  - a spring member an end of which is welded inside one of said arms, whereas the second end is bent towards said arms and is inserted into a corresponding opening in the second arm, a cam being integral with said second arm, said cam engaging and deforming said spring member when the arms are rotated to bring the jewel from its opening position to its closing position or vice versa.
5. The jewel of claim 4, in which the bent end of the spring member engages the cam when the jewel is opened, acting as a travel end means to limit the arm opening out.

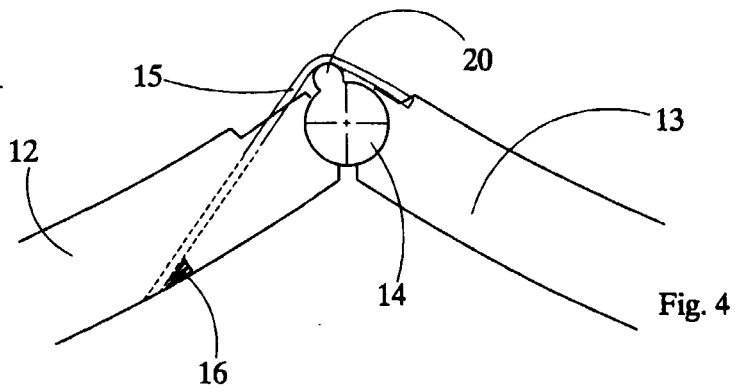
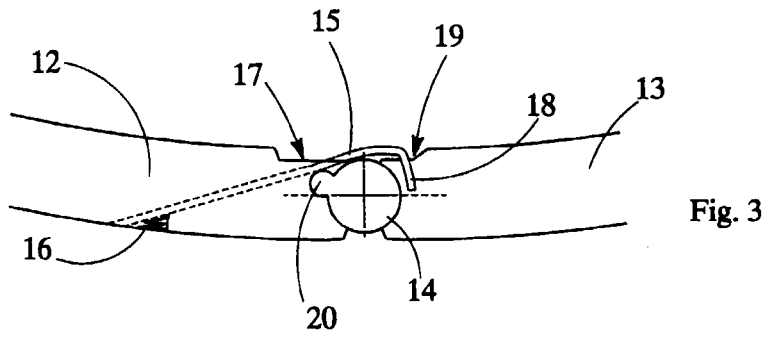
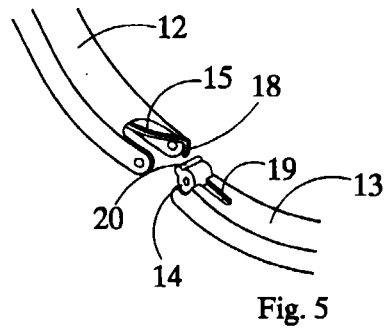
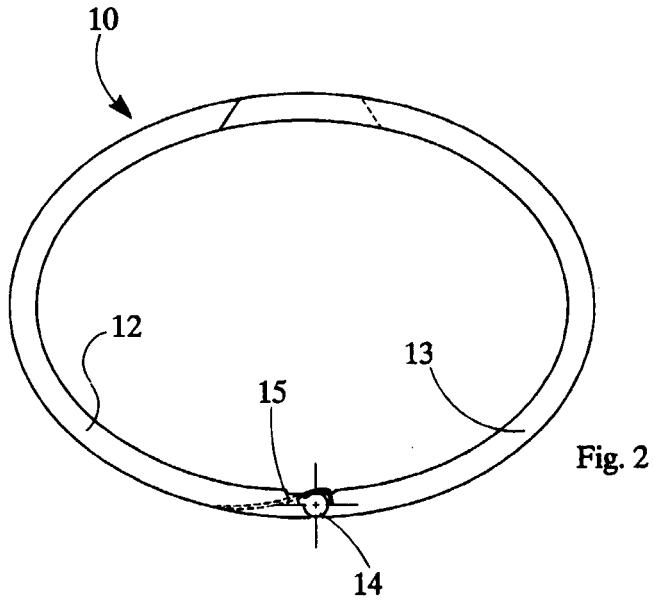
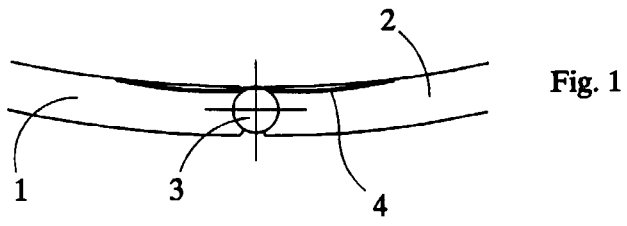



European Patent  
Office

EUROPEAN SEARCH REPORT

Application Number  
EP 99 10 6859

DOCUMENTS CONSIDERED TO BE RELEVANT			
Category	Citation of document with indication, where appropriate, of relevant passages	Relevant to claim	CLASSIFICATION OF THE APPLICATION (Int.Cl.7)
X	EP 0 375 565 A (CREATES ALLAN B ;BREQUE JEAN (FR)) 27 June 1990 (1990-06-27) * column 1, line 38 - column 2, line 5 * * column 5, line 51 - column 6, line 9 * * figures 1-7 *	1,3	A44C5/12 A44C7/00 A44C9/00
X	US 2 713 863 A (HANDERSON PHILIP C.) 26 July 1955 (1955-07-26) * column 2, line 13-20; figures 1,3 *	1	
A	US 3 805 548 A (MATWIJCOW J) 23 April 1974 (1974-04-23) * abstract; figures *	1-4	
P,X	US 5 816 073 A (BARDISBANYAN VAHRAN) 6 October 1998 (1998-10-06) * the whole document *	1,3	
			TECHNICAL FIELDS SEARCHED (Int.Cl.7)
			A44C
The present search report has been drawn up for all claims			
Place of search MUNICH		Date of completion of the search 1 October 1999	Examiner Kock, S
<p>CATEGORY OF CITED DOCUMENTS</p> <p>X : particularly relevant if taken alone                      Y : particularly relevant if combined with another document of the same category                      A : technological background                      O : non-written disclosure                      P : intermediate document</p> <p>T : theory or principle underlying the invention                      E : earlier patent document, but published on, or after the filing date                      D : document cited in the application                      L : document cited for other reasons</p> <p>&amp; : member of the same patent family, corresponding document</p>			

EPO FORM 1503 03.92 (P04C01)

**ANNEX TO THE EUROPEAN SEARCH REPORT  
ON EUROPEAN PATENT APPLICATION NO.**

EP 99 10 6859

This annex lists the patent family members relating to the patent documents cited in the above-mentioned European search report. The members are as contained in the European Patent Office EDP file on  
The European Patent Office is in no way liable for these particulars which are merely given for the purpose of information.

01-10-1999

Patent document cited in search report		Publication date	Patent family member(s)	Publication date
EP 0375565	A	27-06-1990	AT 97556 T	15-12-1993
			CA 2003175 A	23-06-1990
			DE 68910951 D	05-01-1994
			DE 68910951 T	17-03-1994
			US 4991409 A	12-02-1991
-----				
US 2713863	A	26-07-1955	NONE	
-----				
US 3805548	A	23-04-1974	NONE	
-----				
US 5816073	A	06-10-1998	NONE	
-----				