



Europäisches Patentamt  
European Patent Office  
Office européen des brevets



(11) **EP 0 987 183 B1**

(12) **EUROPEAN PATENT SPECIFICATION**

(45) Date of publication and mention  
of the grant of the patent:  
**23.06.2004 Bulletin 2004/26**

(51) Int Cl.7: **B65D 5/52, B65D 5/50**

(21) Application number: **99117939.1**

(22) Date of filing: **14.09.1999**

(54) **Shipping and display package**

Transport- und Schaustellungsbehälter  
Récipient de transport et de présentation

(84) Designated Contracting States:  
**AT BE CH CY DE DK ES FI FR GB GR IE IT LI LU  
MC NL PT SE**

(30) Priority: **14.09.1998 EP 98117364**

(43) Date of publication of application:  
**22.03.2000 Bulletin 2000/12**

(73) Proprietor: **Kraft Foods R & D, Inc.  
Zweigniederlassung München  
81737 München (DE)**

(72) Inventors:  
• **Maier, Hans  
79669 Zell (DE)**

- **Dagestadt, Olav  
1067 Oslo (NO)**
- **Frigstad, Olav  
1433 Vinterbro (NO)**
- **Hoivik, Truls  
1335 Snarøia (NO)**

(74) Representative: **HOFFMANN - EITLÉ  
Patent- und Rechtsanwälte  
Arabellastrasse 4  
81925 München (DE)**

(56) References cited:  
**DE-C- 3 835 359**                      **FR-A- 2 675 774**  
**US-A- 2 132 604**                      **US-A- 2 260 428**

**EP 0 987 183 B1**

Note: Within nine months from the publication of the mention of the grant of the European patent, any person may give notice to the European Patent Office of opposition to the European patent granted. Notice of opposition shall be filed in a written reasoned statement. It shall not be deemed to have been filed until the opposition fee has been paid. (Art. 99(1) European Patent Convention).

## Description

### TECHNICAL FIELD

**[0001]** The present invention relates generally to containers and particularly to packages which are folded from a single package blank in accordance with the preamble of claims 1 and 17 and to package blanks as such in accordance with the preamble of claim 10. These packages comprise at least one inclined wall and can conveniently be used for storing, shipping and for shop presentation, especially in connection with foodstuff, in particular square or rectangular packages of cheese, breakfast cereals, bars of confectionery, such as chocolate bars, etc.

### BACKGROUND ART

**[0002]** Numerous packages which are foldable from a single package blank are known in the art. Such packages are required to be stacked on shelves and to display the products in a manner so that a customer standing in front of the display shelf has a full view of the displayed product and can easily reach same.

**[0003]** Conventionally, such packages comprised two separate pieces, a bottom piece with an inclined wall and a separate lid. In the bottom piece, the inclined wall, typically the back wall of the package, was formed by providing a double layered wall. The outer layer of this double layered back wall was oriented perpendicularly to the bottom wall, and the inner layer of this double layered back wall extended between the upper edge of the outer layer and a base line on the bottom wall. Depending on the distance between the base line and the line of contact between the outer back wall and the bottom wall, the angle of inclination of the inner layer could be pre-selected.

**[0004]** With these conventional packages, problems arise as to the amount of waste material in the production of the corresponding package blank and as to possible misplacement of the separate lid as well as the necessity of manual packing operations on account of the separate lid.

**[0005]** US 2,132,604 discloses a display package in accordance with the preamble of claims 1 and 17, which is manufactured from a single package blank. The package comprises a multi-layered side wall at the back side of the display package. Several layers facing the inside of the package are inclined and form an obtuse angle with the bottom wall. These inclined layers of the back-side wall support the contents of the box during shipping and display. An automatized folding of the package blank and packing operation are not contemplated.

### SUMMARY OF THE INVENTION

**[0006]** Under consideration of the known packages, it is an underlying technical problem of the present inven-

tion to provide a package which is manufactured from a single blank and to reduce waste material in its manufacture. Further, it is an underlying technical problem of the present invention to provide a package blank for producing such a package in an automatized way.

**[0007]** According to one aspect of the present invention, this problem is solved by a package in accordance with claim 1. Advantageous embodiments of this package are described in the dependent claims 2 to 6.

**[0008]** In another aspect according to the invention, there is provided a foldable package blank in accordance with claim 10. Advantageous embodiments of this package blank are defined in the dependent claims 11 to 16.

**[0009]** In another aspect according to the invention, the preferred use of the inventive package is claimed in claims 7 to 9.

**[0010]** Finally, a second embodiment of the invention is described in claim 17. A preferred variant thereof is derivable from claim 18.

**[0011]** The invention provides significant advantages over previously known packages and blanks therefor. The design is such that the packages comprise a plurality of side walls, at least one of which is at least partially a single-layered support side wall. This support side wall provides support for the products to be packaged, i.e. these products typically rest with a point or line of contact with the bottom wall against at least part of the support side wall. In order to obtain an optimal display of the packaged goods to the customer, this part of the support side wall forms an obtuse angle with the bottom wall. It is also contemplated that substantially the entire support side wall is formed into this obtuse angle. In addition to the plurality of side walls or side wall segments, which may define any chosen cross-sectional shape, i.e. triangular, square, hexagonal or other polygonal shapes, circular or arc-shaped segments, and/or a combination thereof, a bottom wall and a top are provided so as to enclose a package space. This package space does not necessarily need to be enclosed by contiguous wall segments without any gaps and/or openings. Rather, the configuration in this respect should be designed to fulfill requirements as regards preventing loss of the package contents, providing the required ventilation as well as sufficient surface area to provide the outside of the package with the desired imprints, such as expiration dates, logos, etc. Erection of the package from the blank and the package's stability is ensured in accordance with the invention by the necessary flaps and tabs so as to permit, by folding and attaching, formation of the package from the blank. A further side wall of the inventive package, this side wall being located opposite the support side wall, is at least partially removable. Additionally, at least part of the top can be removable. Removal of the removable part of the support side wall and, if applicable, that of the top, provides access to the package space.

**[0012]** Such removal can be enabled by suitable de-

sign measures such as weakening lines. At present, perforations are preferred.

**[0013]** The support side wall is at least partially single-layered. This opens up the possibility to automatize the folding and packaging operation. The support side wall forms in a single-layered portion an obtuse angle with the bottom wall and supports the contents of the box during shipping and display. In the single-layered portion of the support wall, a protrusion towards the inside of the display package is formed. This protrusion can be pushed in from the outside of the folded package which opens up the possibility for an easy automatization of the production and packaging process.

**[0014]** A preferred embodiment of the invention suggests, in combination with at least one product to be packed, that the obtuse angle is selected so that a perpendicular which is dropped from the center of gravity of the product to the plane of the bottom wall, passes through the support side wall. For selecting this angle, this product should be directly adjacent to the support side wall. This feature advantageously ensures that even without any further action of locking the package contents, the package securely rests against the obtusely inclined side wall and the bottom wall.

**[0015]** A further preferred feature of the inventive solution contributes to the locking of the package contents. Accordingly, the further side wall opposite the support side wall is single-layered and at least part thereof forms an acute angle with the bottom wall. Hence, this further side wall is, relative to the bottom wall, at least partially inclined in the same direction as the support side wall. Again, it is also contemplated that substantially the entire further side wall is formed into this acute angle. Packaging and transport of stackable goods is considerably enhanced, since the goods are form-locked between the obtusely and the acutely inclined portions of the respective walls. Naturally, it is also possible to extend this feature to walls adjacent to the respective side walls such as top wall segments and/or bottom wall segments.

**[0016]** Preferably, the degree of acuteness of the acute angle is higher than the degree of obtuseness of the obtuse angle. Hence, the difference between the acute angle and the perpendicular to the bottom wall is greater than the difference between the obtuse angle and a perpendicular to the bottom wall.

**[0017]** This feature facilitates ease of manufacture since it enables a line of contact of the acute portion with the packaged product rather than surface area contact and, therefore, permits the enlarging of the tolerances for the wall and/or wall segment dimensions. Although this preferred embodiment clearly defines the two walls to be non-parallel, it is in accordance with the broader aspects of the invention also possible to make use of opposite side walls that are inclined and parallel to one another.

**[0018]** Generally, the obtuse and/or acute side walls can be formed by various means and methods known

to persons having skill in the art. However, it is preferred that the obtuse angle of the single-layered support side wall and the acute angle of the further single-layered side wall are formed by parts thereof projecting to the inside of the package. It is at present preferred to provide the side walls or additionally the adjacent top and bottom wall of the package with elongate openings, typically cuts, so that the portion of the respective walls between the cuts can be folded inwardly so as to form the angled walls. This folding can advantageously take place in-line during formation of the package from the blank.

**[0019]** The inventive package is particularly useful for packaging planar goods. In this context, planar goods are to be understood as two dimensional goods or three-dimensional goods with a thickness that is small in comparison to the length and the breadth.

**[0020]** The most efficient use of the package space provided by a package that is easy to form is made by using the inventive package for packing foodstuff, in particular square or rectangular packages of cheese, breakfast cereals, bars of confectionery, such as chocolate bars, etc.

**[0021]** The inventive package blank referred to above, preferably provides that at least part of the support side wall segment is arrangeable, in the folded disposition of the blank, so as to form an obtuse angle with the bottom wall segment. By utilising the side wall segment for formation of the outer wall of the package as well as the inclined support wall, waste of material in the production of blanks is advantageously reduced. Further, at least part of at least one further side wall segment or additionally of the at least one top segment is or are removable to provide, by removal in the folded disposition of the blank, access to the package space.

**[0022]** Hence, ease of access is improved without adversely affecting the stackability of the finished packages. Further, this design permits the production of the inventive package blank in a one-step operation.

**[0023]** Automatic manufacturing of the blank and the package from the blank requires a high speed operation. To meet this requirement, the present invention advantageously further provides that the inventive blank is punched from one piece. Preferably, filling of the inventive package takes place in-line upon formation of the package from the blank.

**[0024]** Those skilled in the art will be familiar with the methods of manufacture of the blanks of this invention, whether the blanks are made of plastic, paper or other suitable materials. They will also be able to select suitable methods of folding the blanks, as already mentioned, preferably already about the product items to be packaged, and suitable ways of fixing the blank to form a package, which might be by means of adhesive if not welding or hot-melt gluing.

### BRIEF DESCRIPTION OF THE DRAWINGS

**[0025]** The invention is described in greater detail in the following, by way of purely exemplary embodiments represented schematically in the following drawings, in which:

- Fig. 1 shows a plan view of a package blank in accordance with a first embodiment of the present invention;
- Figs. 2 to 4 show perspective views of the inventive package blank of the first embodiment in sequential manufacturing steps;
- Fig. 5 shows a plan view of a package blank in accordance with a second embodiment of the present invention;
- Figs. 6 to 8 show perspective views of the inventive package blank in accordance with the second embodiment in sequential manufacturing steps;
- Figs. 9 to 10 show a plan view of a part of a blank and a perspective view of the package according to a further embodiment not covered by the appended claims; and
- Fig. 11 and 12 show a plan view of a part of a blank and a perspective view of the package according to a further embodiment of the invention.

### DESCRIPTION OF THE PREFERRED EMBODIMENTS

**[0026]** In the following detailed description of preferred embodiments, similar reference signs are used throughout for the same or corresponding parts of the inventive package and the inventive package blank.

**[0027]** A shipping and display package according to a first embodiment of the present invention is shown in Fig. 1 in plan view in its configuration after manufacture of the blank.

**[0028]** It comprises, in the centre of Fig. 1 from the left to the right, a front wall attachment flap 12, a front wall segment 14 which forms, in the folded disposition of the blank, an inclined front wall, a top wall segment 16, rear wall segments 20 and 22, a bottom wall segment 26, an outer front wall segment 40 and, finally, an inner front wall segment 38. Top wall segment 16 extends in Fig. 1 to the top and bottom into outer side wall segments 18. These outer side wall segments 18 are provided with inclined edges 19, the function of which will be discussed in greater detail below.

**[0029]** Rear wall segment 20 extends, in Fig. 1 to the top and bottom, into side wall enforcement flaps 24.

**[0030]** Bottom wall segment 26, in turn, extends to the top and bottom into inner side wall segments 28 which are provided with inclined edges 29, the function of which will also be discussed in greater detail below. To the left and right of the respective inner side wall segments 28 are rear wall locking flaps 30 with tongues 32 and front wall enforcement flaps 36, respectively.

**[0031]** In this connection, it is to be noted that terminology such as "front" and "rear" as well as "top" and "bottom", etc. are used for the sake of simplification of the description and is not intended to limit the scope of the present invention, unless explicitly stated.

**[0032]** If applicable, crease lines or fold lines are located within the various wall segments and are adapted to enable folding of adjacent segments along these lines, substantially without deformation of the respective segments. A skilled person will be aware as to how to best embody this function.

**[0033]** Referring again to Fig. 1, it is evident that side wall segments 18 and 28 are of approximately equal size. Similarly, the dimensions of front attachment flap 12 substantially correspond to the dimensions of the front wall segments 38,40. Upon manufacture of the package from the blank in accordance with the first embodiment of the present invention, these segments come to overly one another, so that this dimensioning maintains ease of fabrication.

**[0034]** Turning now to Fig. 2, in which the blank of Fig. 1 is depicted in a perspective view, several arrows indicate the first steps of forming the inventive blank into the inventive package. Accordingly, arrow A indicates how the rear wall portion 22 is folded away from the rear wall segment 20. This infolding of segments 22 and 23 into what will become the interior of the package in the folded disposition of the blank, does not necessarily need to be the first step in the formation of the package. However, this step as indicated by arrow A should be carried out before the respective side wall segments are folded and provide the blank with initial stability. Foldable wall segment 22 is foldable on account of cut 27 (compare Fig. 1). Further, recesses between the wall segments 22, 23 maintain a precise definition of fold lines.

**[0035]** Arrow B indicates a subsequent folding step during which side wall enforcement flaps 24 are folded upwards along their respective crease or fold lines. In a following step, rear wall segment 20 together with top wall segment 16, side wall segment 18 and the inclined front wall segment 14 are folded upwards so that the side wall reinforcement flaps 24 are located adjacent to the fold lines between inner side wall segments 28 and the bottom wall segment 26. This folding step also causes the foldable portion 23 of the bottom wall segment 26 to approach the non-foldable portion of the latter and to assume a position substantially parallel thereto. Accordingly, the obtuse angle of the folded rear wall portion

22 relative to the bottom wall segment 26 in the folded disposition of the blank is achieved, as will be noted in connection with Fig. 3.

**[0036]** Hereafter, the inner side wall segments 28 are folded upwardly and the rear wall locking flaps 30 are folded so that they reach around the unfolded portion 20 of the rear wall that is not folded inwardly. Subsequently, tongues 32 of the rear wall locking flap are inserted into their corresponding recesses 34. During or after this folding step, the front wall enforcement flaps 36 are also folded upwardly, as indicated by arrow C.

**[0037]** In order to complete the formation of the lower parts of the inventive package, the inner front wall segment 38 is folded upwardly, over the front wall enforcement flaps and again downwardly until the front wall locking tabs 42 are insertable into their corresponding recesses 44. Hence, the front wall enforcement flaps 36 come to lie between the inner front wall segment 38 and the outer segment 40 and formation of the lower part of the package is completed, as depicted in Fig. 3.

**[0038]** It will certainly be noted, in particular from Fig. 3, that the folded rear wall portion 22 forms an angle together with the bottom wall 26 that is obtuse, i.e. an angle greater than 90 degrees. Hence, the folded wall portion 22 serves as a support for product to be inserted into the pre-formed package, as will be described in more detail below.

**[0039]** Substantially planar products P, preferably chocolate bars, are inserted into the pre-formed package as a stack, following arrow E in Fig. 3.

**[0040]** Each Product P of the stack rests with one of its narrow sides on the bottom wall 26 and leans simultaneously against the rear wall segment 22 which is folded at an obtuse angle  $\alpha$ . As will surely be noted, this infolding provides a simple, yet effective means to produce an inclined side wall without the necessity to provide an extra wall segment on the blank. Sparing this extra wall segment results in a substantial reduction of blank waste material and, hence, in a substantial reduction of material costs.

**[0041]** The obtuse angle  $\alpha$  is selected so that each Product P will securely rest against an adjacent product or, eventually, against the support walls 22.

**[0042]** To this end, the obtuse angle  $\alpha$  is selected such that the centre of gravity lies beyond the line of contact between support walls 22 and bottom walls 26, beyond as seen from bottom wall segment 26. In other words, if a perpendicular is dropped from the centre of gravity of the Product P at adjacent support wall 22 to the bottom wall 26, it will pass through support wall 22. After packing a stack of products P into the pre-packed package, the top of the package is closed so as to complete formation of the package. This is done by following arrows F and G. Arrow F denotes how the top wall 16 and the inclined front wall 14 are lowered until the front wall attachment flap 12 can engage behind the inner front wall 38. Further engagement takes place between the front wall 14 and the inclined edges 19 and 29 of the

outer and inner side walls, respectively. As can be taken from Fig. 3, the angle of inclination is determined by the angle  $\alpha$  between the edges 19,29 and the bottom wall 26. This angle  $\alpha$  can be selected so that the inclined front wall 14 in a closed disposition of the package (compare Fig. 4) is parallel to the support wall 22.

**[0043]** This design will guarantee that each of the stack of products P is secured within the closed package and that any movement of any of the products in the package is prevented. Hence, breaking open of the package during transport is advantageously inhibited.

**[0044]** In order to improve this effect, the preferred variation of this embodiment provides that the angle of inclination of the inclined front wall 14 is greater than that of the support wall 22. Accordingly, the front wall 14 in combination with the support wall 22 will engage with a stack of products along a line of contact in the upper region of the package and tolerance requirements during manufacture of the blank and package are reduced.

**[0045]** Manufacture of the package from the blank in accordance with this first embodiment of the invention is facilitated since the tolerances required in order to arrange front wall 14 and the back wall 22 in parallel are not as tight.

**[0046]** The package is closed by applying strips of adhesive tape to the inclining front wall 14 and the side walls 18 as well as the side walls 18 and the bottom walls 26, as indicated in Fig. 4.

**[0047]** With reference again to Figs. 3 and 4, it will be noted that the top wall of the package in accordance with the first embodiment of the present invention is provided with stacking recesses 48 and stacking tabs 50. If desired, the stacking tabs 50 can be folded upwardly from the top wall 16, as depicted in Fig. 4, so as to mate with corresponding stacking recesses 28 of a package stacked on top. Mating engagement between these stacking tabs 50 and stacking recesses 48 will ensure proper alignment and stability of a stack of inventive packages and, therefore, improve transport conditions and/or display.

**[0048]** Turning now, initially with reference to Fig. 5, to the second embodiment of the present invention, it is to be noted that, for the sake of brevity of this specification, parts and functions similar to the first embodiment of the present invention will only be briefly referred to. Naturally, although some features of the invention are only explained with reference to one of the embodiments, it is within the scope of this invention also possible to combine such features in a further embodiment.

**[0049]** In the central part of Fig. 5 are depicted, as seen from left to right, a side wall segment 118, rear wall segments 120,122, a further side wall segment 118, front wall segments 113,114, and finally a package attachment flap 112.

**[0050]** Extending from the various segments just described, downwardly in Fig. 5, are various top wall segments 116. Located opposite to the top wall segment and integrally joined to the side, front and rear wall seg-

ments are upper wall segments 126. As can be taken from Fig. 5, two pairs of top 116 and bottom 126 wall segments are provided with clearance recesses 119, the function of which will be discussed in greater detail below.

**[0051]** As is also evident from Fig. 5, the foldable support rear wall portion 122 is separated from the rear wall portion 120 by elongate openings 127. Similarly, the foldable front wall portion 114 is separated from front wall portion 113 by elongate openings 129. These elongate openings 127, 129 are to be understood as alternatives to the cuts 27 described in connection with the first embodiment of the present invention. Although both of these embodiments enable the present invention to be carried out, the elongate openings are preferred since in-line filling of the package upon formation of the package from the blank is facilitated.

**[0052]** The elongate openings 127, 129 extend into the wall segments adjacent to the respective rear wall portion 122 and front wall portion 114, and define a foldable bottom wall portion 123 and a foldable top wall portion 115, respectively.

**[0053]** Still with reference to Fig. 5, perforations 146 are depicted which, in the folded disposition of the blank, are joined to form a substantially continuous weakening line.

**[0054]** Turning now to Fig. 6, a stack of products P to be disposed in the package, in accordance with the second embodiment of the present invention, is depicted.

**[0055]** Fig. 6 denotes the starting position for fully automated filling and package-formation. Initially, the stack of products P is disposed on the rear wall portions 120, 122. Subsequently, side wall segments 118 are folded upwards and their adjacent top and bottom wall segments 116, 126 inwardly, so that they abut the stack of products P. In a folding step, the top and bottom wall segments 116 and 126 adjacent to the rear wall portions 120 and 122 are folded upwardly and attached to the corresponding top and bottom wall segments adjacent to the side wall segments 118.

**[0056]** Hereafter, the foldable rear wall portion 122 is pushed toward the interior of the pre-formed package until the disposition depicted in Fig. 7 results. It will surely be noted that the stack of products is tilted or inclined relative to the top wall edges visible in Fig. 7. The degree of this tilting inclination corresponds to the obtuse angle preselected by positioning and dimensioning the foldable rear wall portion 122 and the foldable bottom wall portion 123 to one another and to the unfolded portion 120 of the rear wall. However, it is noted that the uppermost point of the stack of products P in Fig. 7 is to be flush with the upper edge of side wall segments 118.

**[0057]** In order to proceed with the in-line packaging and package-forming process, the foldable front wall portion 114 is folded towards the interior of the package so as to lock the products P into place. As is to be noted, the innermost top and bottom wall segments are provided with clearance recesses 119 for the following rea-

sons:

**[0058]** As there is a considerable overlap between the various top wall segments 116, which are attached to one another, the top and bottom wall segments extending from the side wall segments 118 would interfere with the folding in of the locking front wall 114 and the support wall portion 122. In order to avoid such interference, recesses 119 are provided, as can be taken from Figs. 5 and 6.

**[0059]** A further step in the in-line filling and packaging process relates to closing the pre-formed package and defining a package space therein. This is achieved by folding over the front wall segments 113 and 114 in the direction of arrow H in Fig. 7. After folding over the front wall segments 113, 114, the respective top wall segments 116, 126 adjacent thereto are folded downwards and suitably attached in their contact region with abutting top and bottom wall segments. Further, the package attachment flap 112 is attached to the neighbouring side wall segments 118 in order to close the package and to provide it with stability. Preferably, this further step just described is carried out simultaneous to the step of folding the front wall portion 114 inwardly; as previously mentioned, this in-folding in connection with closing the package achieves the advantageous locking effect.

**[0060]** Finally, with reference to Fig. 8, the completely folded blank and the final disposition of the package is depicted. Similar to the first embodiment described with reference to Figs. 1 through 4, the inwardly projecting front wall portion 114 forms an acute angle  $\alpha$  relative to the bottom wall 126. As the support and the locking effect of the wall portions 122 and 114, respectively, correspond to that described in connection with the first embodiment of the present invention, reference is made thereto.

**[0061]** In order to display the packed products P on a shelf, the complete package as depicted in Fig. 8 is to be turned by 90 degrees, so that the top wall 116 faces upwards. On account of the inwardly projecting inclined walls of 114, 122, a secure support and reliable locking of the product is achieved and, simultaneously, substantially planar and symmetric outer limits of the package are obtained. Hence, the package is easy to stack and, therefore, safe transport is ensured.

**[0062]** In order to open the inventive package, part of the front wall, part of the side walls and, additionally, part of the top wall is removed by separating along the perforation 146. To facilitate the gripping of the parts to be separated, a semi-circular opening is provided, as depicted in the drawings.

**[0063]** Fig. 9 and 10 show another embodiment not covered by the appended claims. Fig. 9 and 10 are closely related to Fig. 1 and 3 and, therefore, for the same or corresponding parts of the inventive package and the inventive package blank the same reference signs are used.

**[0064]** Fig. 9 shows only a part of the package blank including the bottom wall segment 26, side wall seg-

ments 28 with a locking flap 30 and a tongue 32, respectively, and a rear wall segment 20 with side wall enforcement flaps 24 and recesses 34 for receiving the tongues 32. There are two cuts 56 which are perpendicular to the fold line between the bottom wall segment 26 and the side wall segments 28 in a region near to the crossing 60 of the fold line between the rear wall segment 20 and bottom wall segment 26 on the one hand and on the other hand, the bottom wall segment 26 and the side wall segments 28, respectively. The crossing 60 forms the corner of the folded package. Moreover, there are fold lines 58 connecting the crossing 60 with the respective ends of the cuts 56, as can be seen from Fig. 9.

**[0065]** During the folding operation or in the already folded state, the regions bounded by the cut 56, the fold lines 58 and the crossing 60 can be pushed to the inside of the package which leads to protrusions 55 as indicated in Fig. 10. These protrusions 55 serve as a stop against which the lower portions of the rear most product come into an abutting engagement. This ensures that the lower edge of the rear most product is always spaced a predetermined distance from the lower edge between the bottom wall 26 and the rearward side wall 20 of the display package. This allows the products P to be packaged to be stored in the desired, inclined position.

**[0066]** Additionally, there is a certain pattern of surface regions of the bottom wall which are treated in a way to enhance the friction between the products P and the inner surface of the bottom wall 26. This higher friction can be achieved by different surface treatments. A preferred possibility is the application of an adhesive on certain regions of the inner bottom wall which serve to prevent the sliding of the products in the display package. Preferably, the adhesive is a hot-melt adhesive and applied in one or more, preferably two, longitudinal tracks 62 between the rearward side surface 20 and the front surface of the display package.

**[0067]** Fig. 11 and 12 show yet another embodiment of the invention. The shipping and display package 210 shown in Fig. 12 is formed from a blank 201 which is shown in Fig. 11. The blank has a bottom wall segment 226, side wall segments 228 and a rear wall segment 220 integrally formed with a top wall segment 216. Additionally, rear wall segments 230 are contiguous to the side wall segments 228, leaving in the folded state a space of thickness d, the effect of which together with the rear wall segment 220 will be explained later.

**[0068]** As can be seen from a comparison of the height H1 of the side wall segments 228 and the height H2 of the rear wall segment 220, H2 is higher than H1. This allows the rear wall segment 220 to be folded towards the inside of the display package. To this end, fold lines 222 which are parallel to the fold line between the bottom segment 226 and the rear wall segment 220 extend over the rear wall segment and can be used to fold part of the rear wall segment 220, namely the portions 220a and 220b into the interior of the display package.

The remaining portion of the rear wall segment has a height of H3 corresponding to the height H3 of the rear wall segments 230. Therefore, the blank 210 can be folded so that the upper edges 229 of the side wall segments and 231 of the bottom wall segments have the same height over the bottom wall segment 226 as the fold line 221 between the rear wall segment 220 and the top wall segment 216.

**[0069]** After folding the blank 201 shown in Fig. 11 into a three dimensional display package, the rear wall portion of the display package looks like that given in Fig. 12. The portions 220a (not to be seen in Fig. 12) and 220b project into the interior of the package 210 and serve as a stop which allows the products to be shipped and displayed to lie angularly to the direction perpendicular to the bottom wall 226. In this embodiment, as well as all the other embodiment described in this application, again measures can be taken to increase the friction between the bottom wall 226 and the products to be displayed. In the present embodiment, two tracks 262 of a hot-melt adhesive are applied to the bottom surface 226.

**[0070]** All embodiments discussed herein have in common that protrusions are formed which project into the interior of the display packages. These protrusions are formed from the material available to build up the display packages. Moreover, all protrusions are placed into regions of one of the side walls, where these side walls are single-layered. This makes it possible to form the protrusions simply by pushing in the respective portions from the outside of the package into the inside thereof. Therefore, optimum use is made of the material for forming the single-piece blanks and, moreover, the forming of the protrusions can easily be automatized because it is not necessary to perform complicated folding operations within the interior of the packages.

**[0071]** Further embodiments and advantages of the inventive package and the inventive package blank are defined in and by the various combinations of the following claims.

## Claims

1. Shipping and display package (10;110;210), foldable from a single package blank (1;101;201) and comprising:
  - a bottom wall (26;126;226) providing a base for the package during shipping and display,
  - a plurality of side walls (14,18,20,22,28,38,40; 113,114,118,120,122;220,228) and
  - at least one of the sidewalls (14, 28, 38; 113; 228) comprising plural flaps and tabs (12, 30, 42; 112; 230) which are foldable and attachable to other sidewalls (20, 38; 118; 220) so as to form a closed package from the blank,

the package being **characterized by**

- at least one of the side walls (20,22;120,122; 220) being at least partially a single-layered support side wall, at least part of the single-layered portion of the support side wall being folded inwardly so as to project to the inside of the package (10, 110; 210), forming an obtuse angle (o) with the bottom wall so as to support the contents of the box during shipping and display, 5
  - a top (16,116;216) which encloses a package space together with the bottom walls and the plurality of side walls, and 10
  - at least part of at least one further side wall opposite the support side wall or additionally of the top being removable to provide, by removal, access to the package space. 15
2. Package as claimed in claim 1, in combination with at least one product (P) to be packed and **characterized in that** the obtuse angle (o) is selected so that a perpendicular dropped from the centre of gravity of that of the at least one product directly adjacent to the support side wall (22;122;220) to the plane of the bottom wall (26;126;226) passes through the support side wall. 20 25
3. Package as claimed in any of the preceding claims, **characterized in that** the further side wall (14; 113,114) opposite the support side wall is single-layered and at least part thereof forms an acute angle ( $\square$ ) with the bottom wall (26;126,220b). 30
4. Package as claimed in claim 3, **characterized in that** the degree of acuteness of the acute angle ( $\square$ ) is higher than the degree of obtuseness of the obtuse angle ( $\square$ ). 35
5. Package as claimed in any of claims 3 or 4, **characterized in that** the acute angle ( $\square$ ) of the further single-layered side wall (113,114) is formed by an inwardly projecting part (114) thereof. 40
6. Package as claimed in any of claims 3 or 4, further comprising at least partially a friction-enhancing layer (62) on the inner surface of the bottom wall (2b; 12b; 22b), the friction-enhancing layer (62) being preferably formed of hot-melt adhesive. 45
7. Use of the package as claimed in any of the preceding claims for packing planar goods (P). 50
8. Use as claimed in claim 7, **characterized in that** the planar goods are substantially rectangular. 55
9. Use as claimed in claim 7 or 8, **characterized in that** the goods are bars of confectionary, cheese packages, and/or breakfast cereals.

10. Blank (1;101;201), foldable into a package (10;110; 210) and comprising:

- at least one bottom wall segment (26;126; 226);
- a plurality of side wall segments (14,18,20,22,28,38, 40;113,114,118,120,122; 220,228) and
- at least one of the sidewall segments (14, 28, 38; 113; 228) comprising plural flaps and tabs (12, 30, 42; 112; 230) which are foldable and attachable to other sidewalls (20, 38; 118; 220) so as to permit the formation of a closed package from the blank,

the blank being **characterized by**

- at least one of the sidewall segments (20, 22; 120, 122; 220) being at least partially a single-layered support sidewall, at least part of the single-layered portion of the support sidewall being foldable inwardly so as to project to the inside of the package (10, 110; 210) forming an obtuse angle with the bottom wall in the final package (10; 110; 220) so as to support the contents of the box during shipping and display,
- at least one top segment (16;116;216) for enclosing a package space, in the folded disposition of the blank and together with the at least one bottom wall segment and the plurality of side wall segments,
- at least part of at least one further side wall segment or additionally of the at least one top segment being removable to provide, by removal in the folded disposition of the blank, access to the package space.

11. Blank as claimed in claim 10, **characterized in that** at least the support side wall segment (20,22; 120,122) or additionally a top segment or a bottom wall segment is or are provided with elongate openings (27;127) so as to enable said arrangement into said obtuse angle ( $\square$ ).

12. Blank as claimed in claim 10 or 11, **characterized in that** at least part of the further side wall segment (14;114) is arrangeable, in the folded disposition of the blank, so as to form an acute angle ( $\square$ ) with the bottom wall segment (26;126).

13. Blank as claimed in claim 12, **characterized in that** at least the further support side wall segment (114) or additionally a top segment (115) or a bottom wall segment (23;123) is or are provided with elongate openings (27;127,129) so as to enable said arrangement into said acute angle ( $\square$ ).

14. Blank as claimed in claim 12 or 13, **characterized in that**, in the folded disposition of the blank, the

degree of acuteness of the acute angle ( $\square$ ) is higher than the degree of obtuseness of the obtuse angle ( $\square$ ).

15. Blank as claimed in any of claims 10 to 14, **characterized in that** the acute angle ( $\square$ ) of the further side wall segment (113,114) in the folded disposition of the blank is formed by an inwardly projecting part (114) of the further side wall segment.

16. Blank as claimed in any of claims 10 to 15, further comprising at least partially a friction-enhancing layer (62) on the bottom wall segment (26;126;226); the friction-enhancing layer being preferably formed of hot-melt adhesive.

17. Shipping and display package (10), foldable from a single package blank and comprising:

- a bottom wall (26) providing a base for the package during shipping and display,
- a rear wall (20),
- a plurality of side walls (14,18,20,28), at least two of which (28) are opposed to each other, and
- at least one of the sidewalls (14, 28) comprising plural flaps and tabs (12) which are foldable and attachable to other sidewalls so as to form a closed package from the blank,

the package being **characterized by**

- at least one of the side walls (28) being at least partially a single-layered support side wall comprising two cuts (56), which are approximately perpendicular to the fold line between the bottom wall (26) and the side walls (28) and are formed in a region near to the crossing (60) of the fold line between the rear wall (20) and the bottom wall (26) on the one hand and on the other hand, the bottom wall (26) and the side walls (28), respectively, each cut extending on both sides of the fold line between the bottom wall (26) and the side walls (28) at least part of the single-layered portion of the support side wall adjacent the cut (56) being folded inwardly so as to project to the inside of the package (10) and so as to form a stop (55) supporting the contents of the box during shipping and display,
- a top (16) which encloses a package space together with the bottom walls and the plurality of side walls, and
- at least part of at least one further side wall opposite the support side wall or additionally of the top being removable to provide, by removal, access to the package space.

18. Package as claimed in claim 17, **characterized in**

**that** the cut (56) is formed in a region near a corner of the package.

## 5 Patentansprüche

1. Transport- und Ausstellverpackung (10;110;210), die aus einem einzigen Verpackungszuschnitt (1; 101;201) faltbar ist und Folgendes aufweist:

- eine Bodenwand (26;126;226), die eine Basis für die Verpackung während des Transports und des Ausstellens schafft,
- mehrere Seitenwände (14,18,20,22,28,38,40; 113,114,118,120,122;220,228) und
- wobei wenigstens eine der Seitenwände (14, 28, 38; 113; 228) mehrere Klappen und Laschen (12, 30, 42; 112; 230) aufweist, die faltbar und an andere Seitenwände (20, 38; 118; 220) derart anbringbar sind, dass aus dem Zuschnitt eine geschlossene Verpackung gebildet wird,

wobei die Verpackung **dadurch gekennzeichnet ist, dass**

- wenigstens eine der Seitenwände (20,22; 120,122;220) wenigstens teilweise eine einschichtige Stütz-Seitenwand ist, wobei wenigstens ein Teil des einschichtigen Abschnitts der Stütz-Seitenwand derart nach innen faltbar ist, dass er zu der Innenseite der Verpackung (10, 110; 210) vorsteht, wobei ein stumpfer Winkel ( $\square$ ) mit der Bodenwand derart gebildet wird, dass die Inhalte der Box während des Transports und des Ausstellens gestützt werden,
- ferner durch eine Oberseite (16,116;216), welche zusammen mit den Bodenwänden und den mehreren Seitenwänden einen Verpackungsraum umschließt, und
- dadurch, dass wenigstens ein Teil der wenigstens einen weiteren Seitenwand entgegengesetzt zu der Stütz-Seitenwand oder zusätzlich der Oberseite entfernbar ist, um durch die Entfernung einen Zugang zu dem Verpackungsraum zu ermöglichen.

2. Verpackung nach Anspruch 1 in Kombination mit wenigstens einem Produkt (P), das zu verpacken ist, und **dadurch gekennzeichnet, dass** der stumpfe Winkel ( $\square$ ) derart gewählt ist, dass eine Senkrechte, die von dem Schwerpunkt desjenigen des wenigstens einen Produkts, das unmittelbar an die Stütz-Seitenwand (22;122;220) benachbart ist, zu der Ebene der Bodenwand (26;126;226) herabgelassen wird, durch die Stütz-Seitenwand tritt.

3. Verpackung nach einem der vorangehenden An-

sprüche,

**dadurch gekennzeichnet, dass**

die weitere Seitenwand (14;113,114) entgegengesetzt zu der Stütz-Seitenwand einschichtig ist und wenigstens ein Teil derselben einen spitzen Winkel (□) mit der Bodenwand (26;126;220b) bildet.

4. Verpackung nach Anspruch 3,

**dadurch gekennzeichnet, dass**

das Ausmaß der Spitzwinkligkeit des spitzen Winkels (□) höher ist als das Ausmaß der Stumpfwinkligkeit des stumpfen Winkels (□).

5. Verpackung nach einem der Ansprüche 3 oder 4,

**dadurch gekennzeichnet, dass**

der spitze Winkel (□) der weiteren einschichtigen Seitenwand (113, 114) durch einen nach innen vorstehenden Teil (114) derselben gebildet wird.

6. Verpackung nach einem der Ansprüche 3 oder 4,

ferner mit wenigstens teilweise einer reibungsverstärkenden Schicht (62) an der Innenfläche der Bodenwand (2b;12b;22b), wobei die reibungsverstärkende Schicht (62) vorzugsweise aus einem Heißschmelz-Haftmittel gebildet wird.

7. Verwendung der Verpackung nach einem der vorangehenden Ansprüche zum Verpacken ebener Güter (P).

8. Verwendung nach Anspruch 7,

**dadurch gekennzeichnet, dass**

die ebenen Güter im Wesentlichen rechtwinklig sind.

9. Verwendung nach Anspruch 7 oder 8,

**dadurch gekennzeichnet, dass**

die Güter Riegel von Süßwaren, Käseverpackungen, und/oder Frühstückscerealien sind.

10. Zuschnitt (1;101;201), der in eine Verpackung (10; 110;210) faltbar ist, und Folgendes aufweist:

- wenigstens ein Bodenwandsegment (26;126; 226),;
- mehrere Seitenwandsegmente (14, 18, 20, 22, 28, 38, 40; 113, 114, 118, 120, 122; 220, 228) und
- wobei wenigstens eines der Seitenwandsegmente (14, 28, 38; 113; 228) mehrere Klappen und Laschen (12, 30, 42; 112; 230) aufweist, die derart faltbar und an andere Seitenwände (20, 38; 118; 220) anbringbar sind, dass die Bildung einer geschlossenen Verpackung aus dem Zuschnitt ermöglicht wird,

wobei der Zuschnitt **dadurch gekennzeichnet ist, dass**

- wenigstens eines der Seitenwandsegmente (20, 22; 120, 122; 220) wenigstens teilweise eine einschichtige Stütz-Seitenwand ist, wobei wenigstens ein Teil des einschichtigen Abschnitts der Stütz-Seitenwand derart nach innen faltbar ist, dass er zu der Innenseite der Verpackung (10, 110; 210) vorsteht, wobei er mit der Bodenwand in der letztendlichen Verpackung (10; 110; 220) derart einen stumpfen Winkel bildet, dass die Inhalte der Box während des Transports und des Ausstellens gestützt werden,
- ferner durch wenigstens ein Oberseitensegment (16;116;216) zum Umschließen eines Verpackungsraumes in dem gefalteten Zustand des Zuschnitts und zusammen mit dem wenigstens einen Bodenwandsegment und den mehreren Seitenwandsegmenten,
- wobei wenigstens ein Teil des wenigstens einen weiteren Seitenwandsegments oder zusätzlich des wenigstens einen Oberseitensegments entfernbar ist, um durch die Entfernung bei dem gefalteten Zustand des Zuschnitts einen Zugang zu dem Verpackungsraum zu ermöglichen.

11. Zuschnitt nach Anspruch 10,

**dadurch gekennzeichnet, dass**

wenigstens das Stützseitenwandsegment (20,22; 120,122) oder zusätzlich ein Oberseitensegment oder ein Bodenwandsegment mit länglichen Öffnungen (27;127) derart versehen sind, dass die Anordnung in den stumpfen Winkel (□) ermöglicht wird.

12. Zuschnitt nach Anspruch 10 oder 11,

**dadurch gekennzeichnet, dass** wenigstens ein Teil des weiteren Seitenwandsegments (14;114) in dem gefalteten Zustand des Zuschnitts derart anordenbar ist, dass ein spitzer Winkel (□) mit dem Bodenwandsegment (26;126) gebildet wird.

13. Zuschnitt nach Anspruch 12,

**dadurch gekennzeichnet, dass**

wenigstens ein weiteres Stützseitenwandsegment (114) oder zusätzlich ein Oberseitensegment (115) oder ein Bodenwandsegment (23;123) mit länglichen Öffnungen (27;127,129) versehen ist oder sind, so dass die Anordnung in den spitzen Winkel (□) ermöglicht wird.

14. Zuschnitt nach Anspruch 12 oder 13,

**dadurch gekennzeichnet, dass** in dem gefalteten Zustand des Zuschnitts das Ausmaß der Spitzwinkligkeit des spitzen Winkels (□) höher ist als das Ausmaß der Stumpfwinkligkeit des stumpfen Winkels (□).

15. Zuschnitt nach einem der Ansprüche 10 bis 14, **dadurch gekennzeichnet, dass** der spitze Winkel ( $\square$ ) des weiteren Seitenwandsegments (113,114) im gefalteten Zustand des Zuschnitts durch einen nach innen vorstehenden Teil (114) des weiteren Seitenwandsegments gebildet wird.

16. Zuschnitt nach einem der Ansprüche 10 bis 15, ferner wenigstens teilweise mit einer reibungsverstärkenden Schicht (62) an dem Bodenwandsegment (26;126;226); wobei die reibungsverstärkende Schicht vorzugsweise aus Heißschmelz-Haftmittel gebildet wird.

### Revendications

1. Emballage de transport et de présentation (10; 110; 210), pouvant être replié à partir d'une seule ébauche d'emballage (1; 101; 102; 201) et comprenant:

- une paroi inférieure (26; 126; 226) formant une base pour l'emballage pendant le transport et la présentation,
- une pluralité de parois latérales (14, 18, 20, 22, 28, 38, 40; 113, 114, 118, 120, 122; 220, 228), et
- au moins l'une des parois latérales (14, 28, 38; 113; 228) comprenant une pluralité de rabats et de languettes (12, 30, 42; 112; 230), qui peuvent être repliées et fixées aux autres parois latérales (20, 38; 118; 220) de manière à former un emballage fermé à partir de l'ébauche,
- l'emballage étant **caractérisé par**
- au moins l'une des parois latérales (20, 22; 120, 122; 220) sont au moins partiellement une paroi latérale de support à une seule couche, qu'au moins une portion de la partie à une seule couche de la paroi latérale de support est repliée vers l'intérieur de manière à faire saillie à l'intérieur de l'emballage (10, 110; 210), et fait un angle obtus (o) avec la paroi inférieure de manière à supporter le contenu de la boîte pendant le transport et la présentation,
- une partie supérieure (16, 116; 216) qui renferme un espace d'emballage, conjointement avec les parois inférieures et la pluralité de parois latérales, et
- une partie d'au moins une autre paroi latérale opposée à la paroi latérale de support ou en supplément la paroi supérieure étant amovible pour fournir, lors de son retrait, un accès à l'espace d'emballage.

2. Emballage selon la revendication 1, en combinaison avec au moins un produit (P) devant être emballé, et **caractérisé en ce que** l'angle obtus (O)

est choisi de telle sorte qu'une perpendiculaire abaissée du centre de gravité du au moins un produit directement adjacent à la paroi latérale du support (22; 122; 220) sur le plan de la paroi inférieure (26; 126; 226) traverse la paroi latérale de support.

3. Emballage selon l'une quelconque des revendications précédentes, **caractérisé en ce que** l'autre paroi latérale (14; 113, 114) est à l'opposé de la paroi latérale de support et est formée d'une seule couche et qu'au moins une partie de cette paroi fait un angle aigu (O) avec la paroi inférieure (26; 126; 220b).

4. Emballage selon la revendication 3, **caractérisé en ce que** la valeur de l'angle aigu (O) est inférieure à la valeur de l'angle obtus (O).

5. Emballage selon l'une quelconque des revendications 3 ou 4, **caractérisé en ce que** l'angle aigu (O) de l'autre paroi latérale à une seule couche (113, 114) est formée par une partie (114) de cette paroi, qui fait saillie vers l'intérieur.

6. Emballage selon l'une quelconque des revendications 3 ou 4, comprenant en outre au moins en partie une couche (62) améliorant le frottement, situé sur la surface inférieure de la paroi inférieure (12b; 22b), la couche (62) améliorant le frottement étant formée de préférence d'un adhésif fusible à chaud.

7. Utilisation de l'emballage selon l'une quelconque des revendications précédentes, pour l'emballage de marchandises plates (P).

8. Utilisation selon la revendication 7, **caractérisée en ce que** les marchandises plates sont essentiellement rectangulaires.

9. Utilisation selon la revendication 7 ou 8, **caractérisée en ce que** les marchandises sont des barres de confiserie, des emballages de fromages et/ou des céréales pour le petit déjeuner.

10. Ebauche (1; 101; 201) pouvant être repliée pour former un emballage (10; 110; 210) et comprenant:

- au moins un segment de paroi inférieure (26; 126; 226),
- une pluralité de parois latérales (14, 18, 20, 22, 28, 38, 40; 113, 114, 118, 120, 122; 220, 228), et
- au moins l'une des parois latérales (14, 28, 38; 113; 228) comprenant une pluralité de rabats et de languettes (12, 30, 42; 112; 230), qui peuvent être repliées et fixées à d'autres parois latérales (20, 38; 110; 220) de manière à former un emballage fermé à partir de l'ébauche,

- l'ébauche étant **caractérisée par**
  - au moins l'un des segments de parois latérales (20, 22; 120, 122; 220) au moins partiellement une paroi latérale de support à une seule couche, au moins une portion de la partie à une seule couche de la paroi latérale de support repliée vers l'intérieur de manière à faire saillie à l'intérieur de l'emballage (10; 110; 210), et faisant un angle obtus avec la paroi inférieure de manière à supporter le contenu de la boîte pendant le transport et la présentation, 5
  - au moins un segment supérieur (16; 116; 216) pour entourer un espace d'emballage, lorsque l'ébauche est dans la position repliée, et conjointement avec le au moins un segment de paroi inférieure et la pluralité de segments de parois latérales, et 10
  - au moins une partie d'au moins un autre segment de paroi latérale ou, en supplément, du au moins un segment de paroi latérale étant amovible pour fournir, par retrait, lorsque l'ébauche est dans la position repliée, un accès à l'espace d'emballage. 20
11. Ebauche selon la revendication 10, **caractérisée en ce qu'**au moins le segment de paroi latérale de support (20, 22; 120, 122) ou en outre un segment supérieur ou un segment de paroi inférieure et ou sont équipé(s) d'ouvertures allongées (27; 127) de manière à permettre ledit agencement dans ledit angle obtus (O). 25 30
12. Ebauche selon la revendication 10 ou 11, **caractérisée en ce qu'**au moins une partie de l'autre segment de paroi latérale (14; 114) peut être agencée, lorsque l'ébauche est dans la position repliée, de manière à faire un angle aigu (O) avec le segment de paroi inférieure (26; 126). 35
13. Ebauche selon la revendication 12, **caractérisée en ce que** l'autre segment de paroi latérale de support (124) ou, en supplément, un segment supérieur (115) ou un segment de paroi inférieure (23; 123) est ou sont pourvu(s) d'ouvertures allongées (27; 127, 129) de manière à permettre ladite disposition sous ledit angle aigu (O). 40 45
14. Ebauche selon la revendication 12 ou 13, **caractérisée en ce que** lorsque l'ébauche est dans la position repliée, la valeur de l'angle aigu (O) est supérieure à la valeur de l'angle obtus (O). 50
15. Ebauche selon l'une des revendications 10 à 14, **caractérisée en ce que** l'angle aigu (O) de l'autre segment de paroi latérale (113, 114) lorsque l'ébauche est dans la position repliée, est formé par une partie saillante intérieure (114) de l'autre segment de paroi latérale. 55
16. Ebauche selon l'une des revendications 10 à 15, comprenant en outre au moins partiellement une couche (62) améliorant le frottement et le segment de paroi inférieure (26; 126; 226); la couche améliorant le frottement étant formée de préférence d'un adhésif fusible à chaud.



Fig. 2

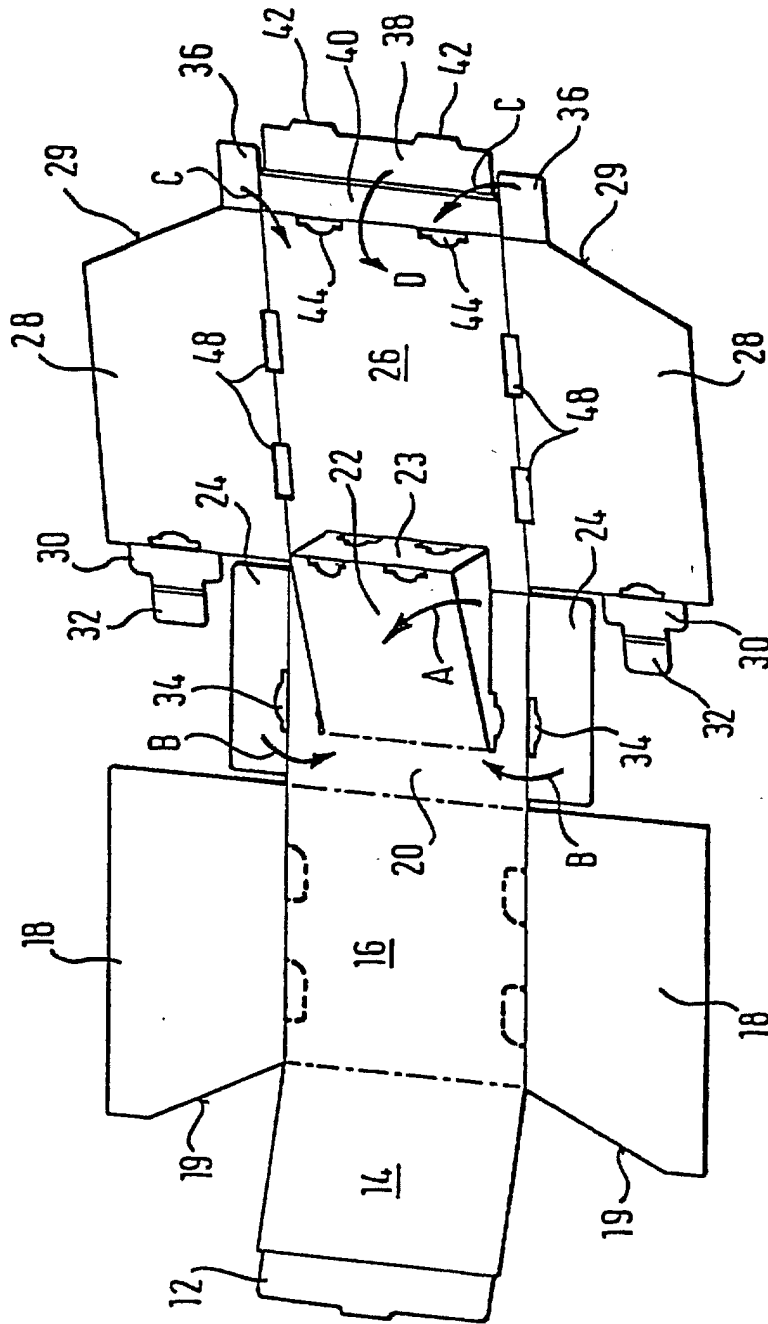
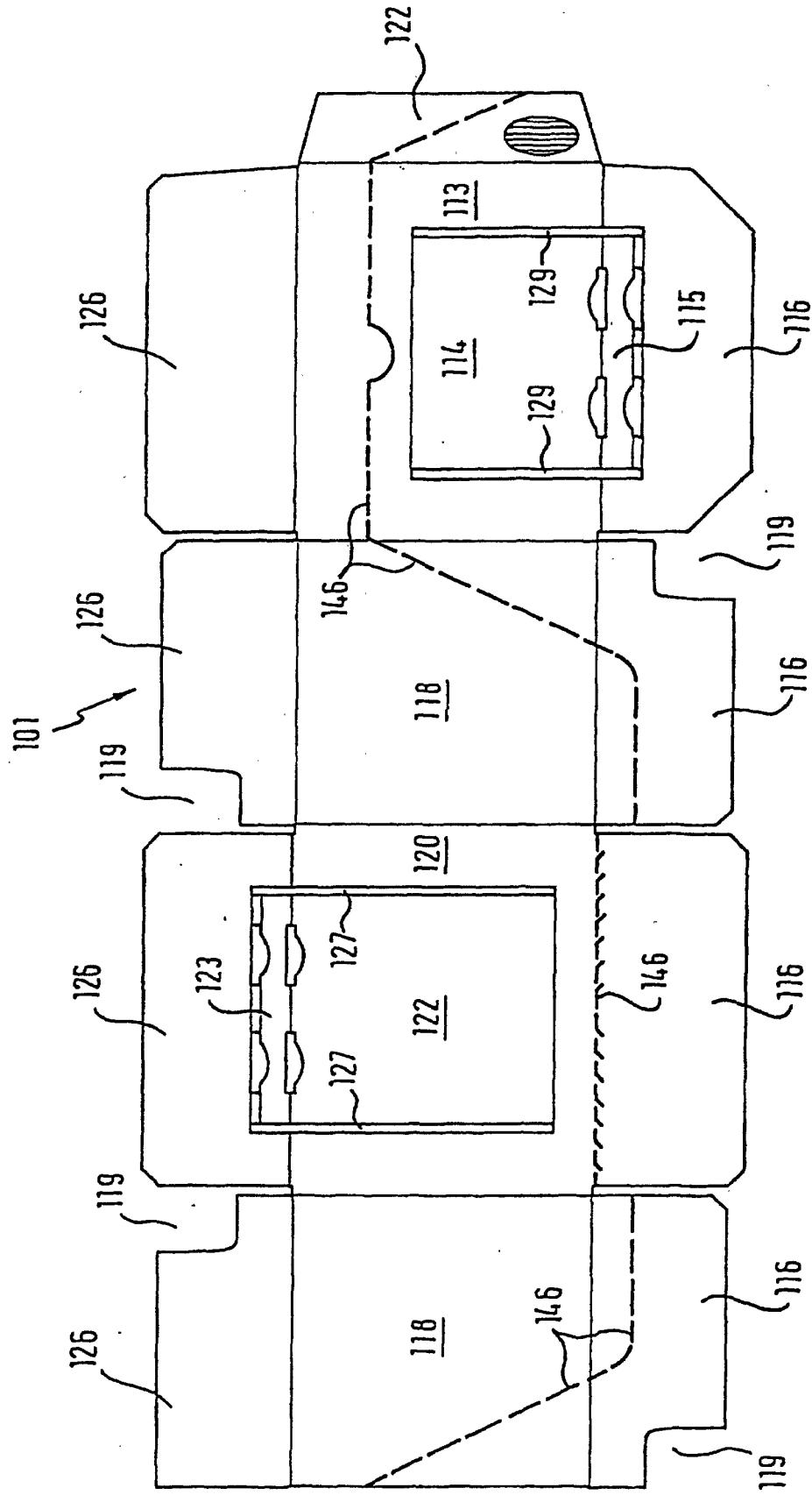



Fig. 5



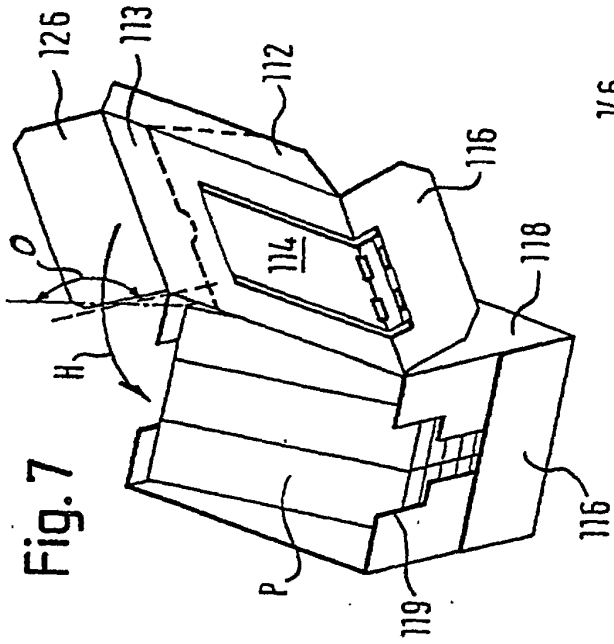

Fig. 7

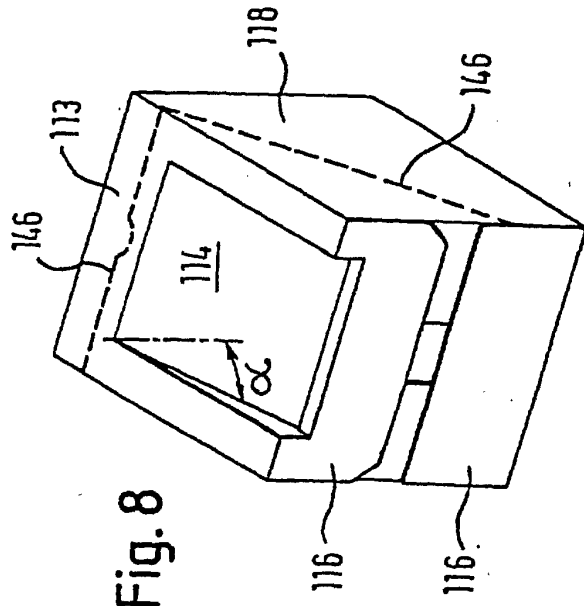
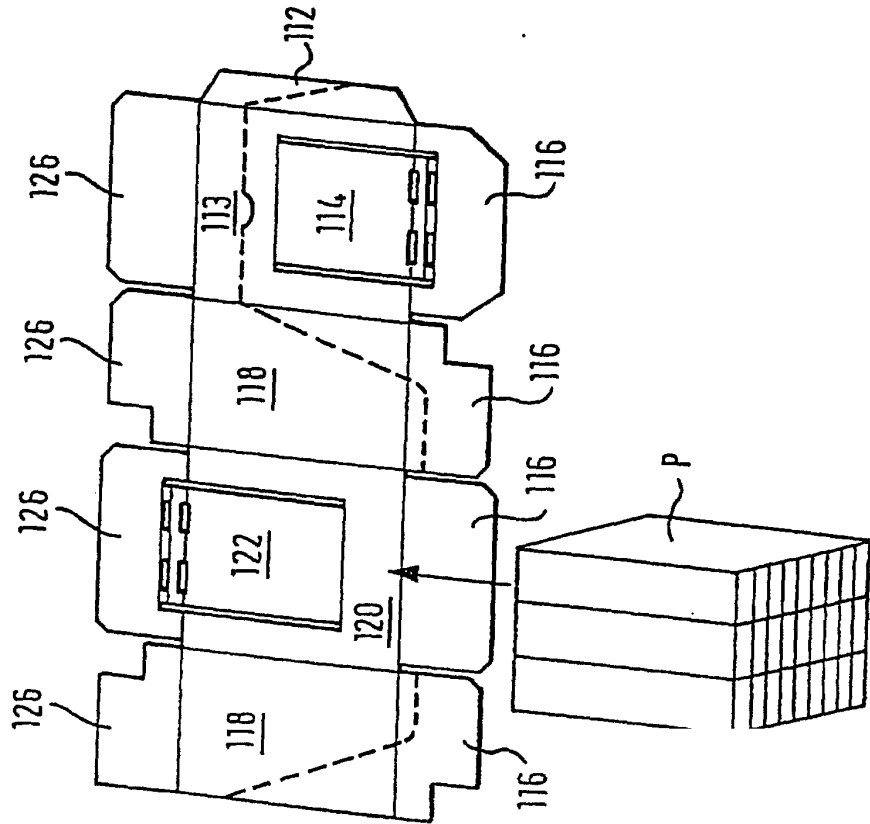

Fig. 8

Fig. 6



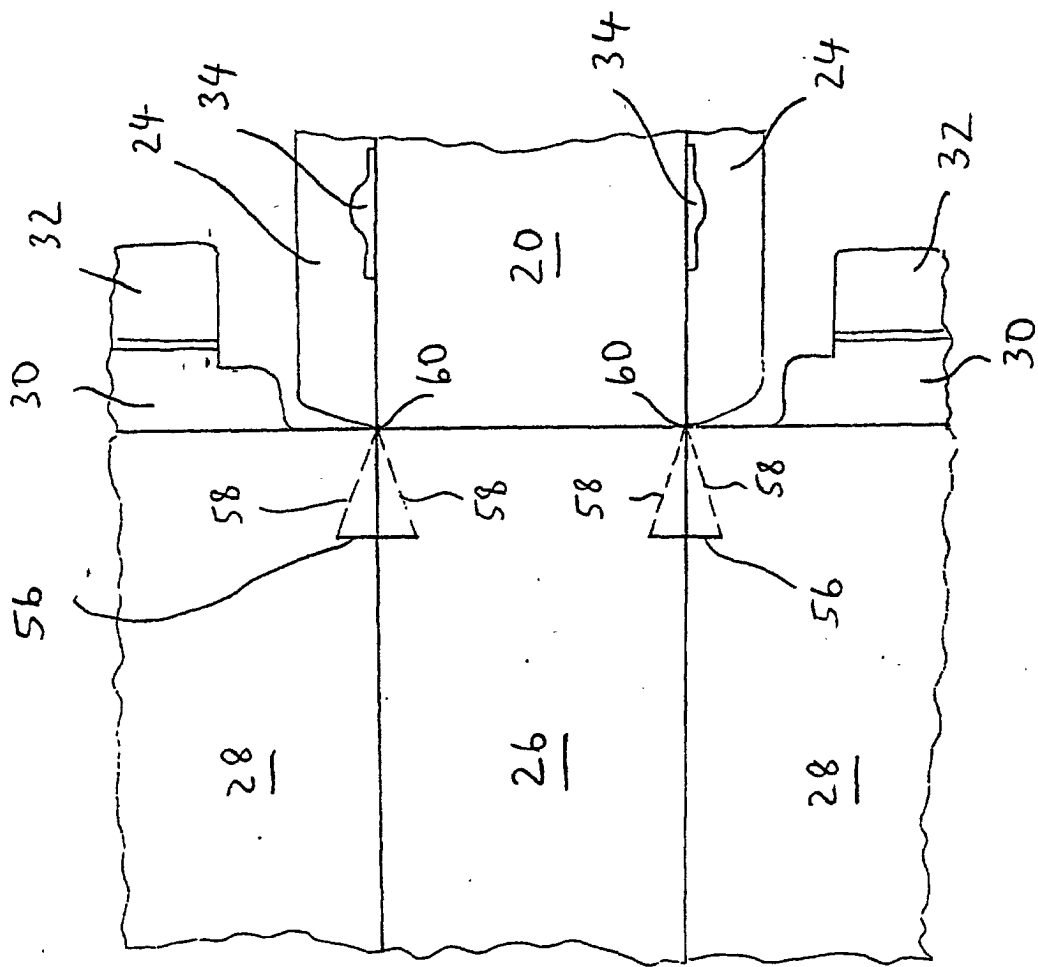

Fig. 9

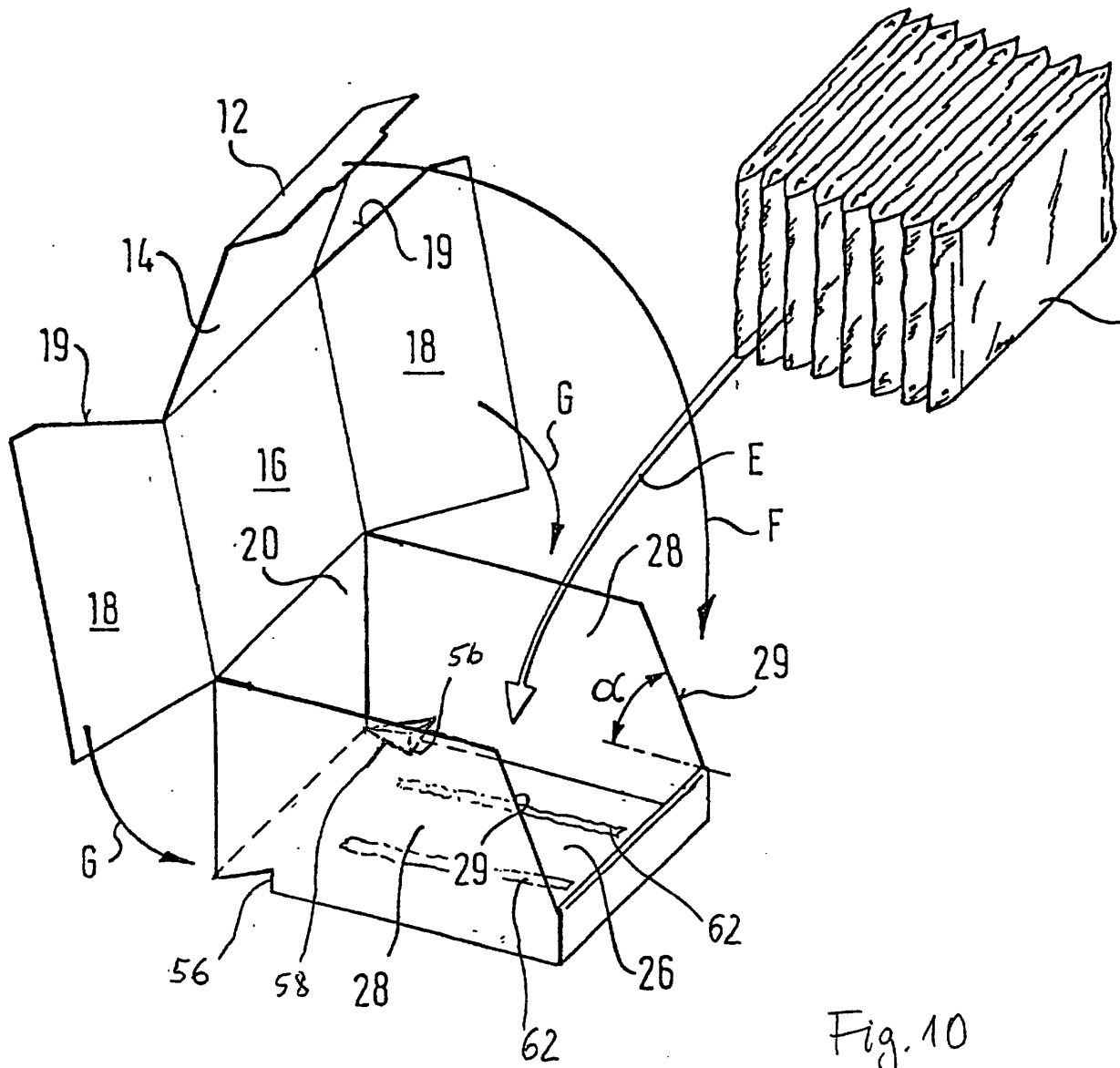

Fig. 10

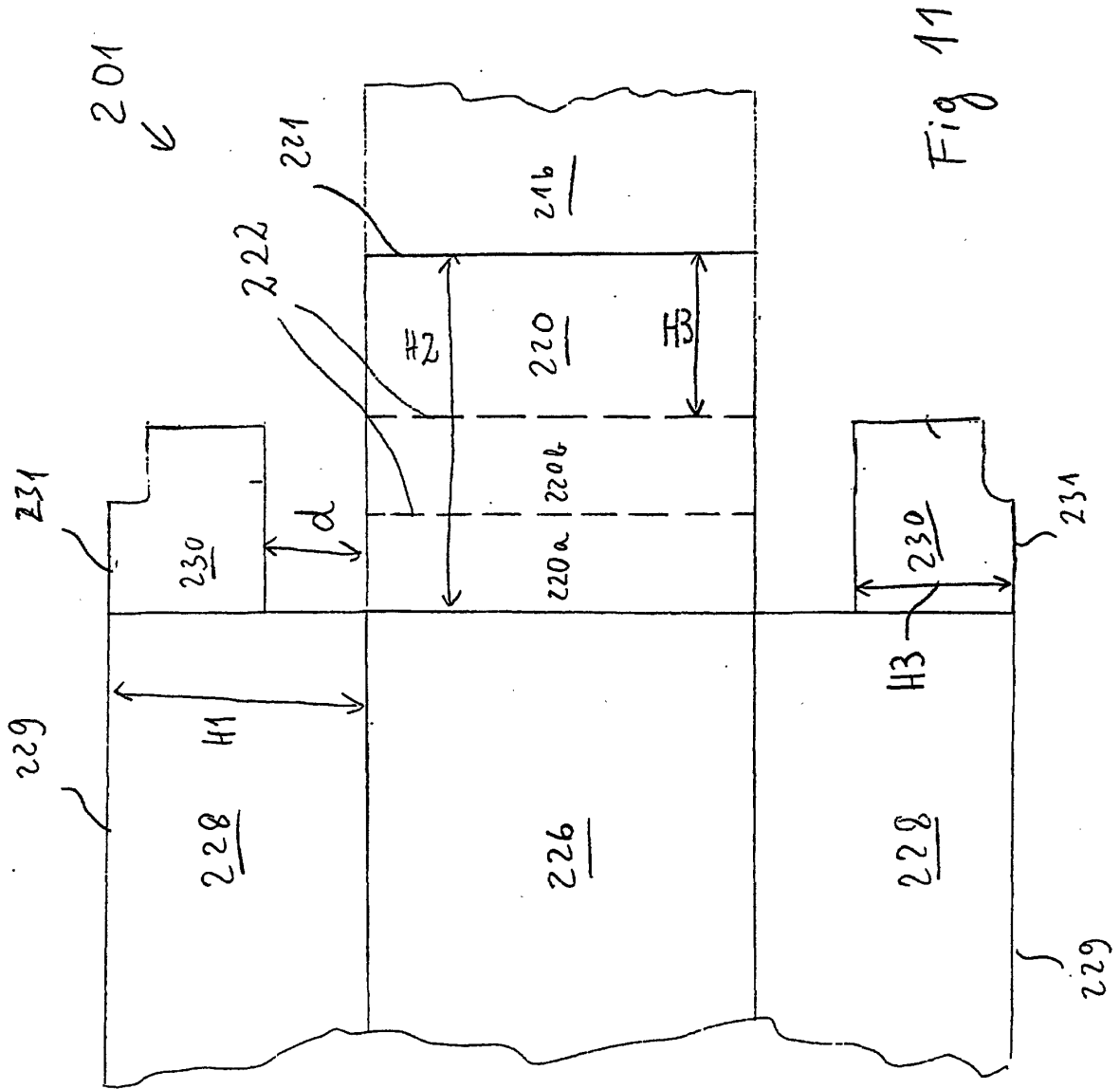

Fig 11

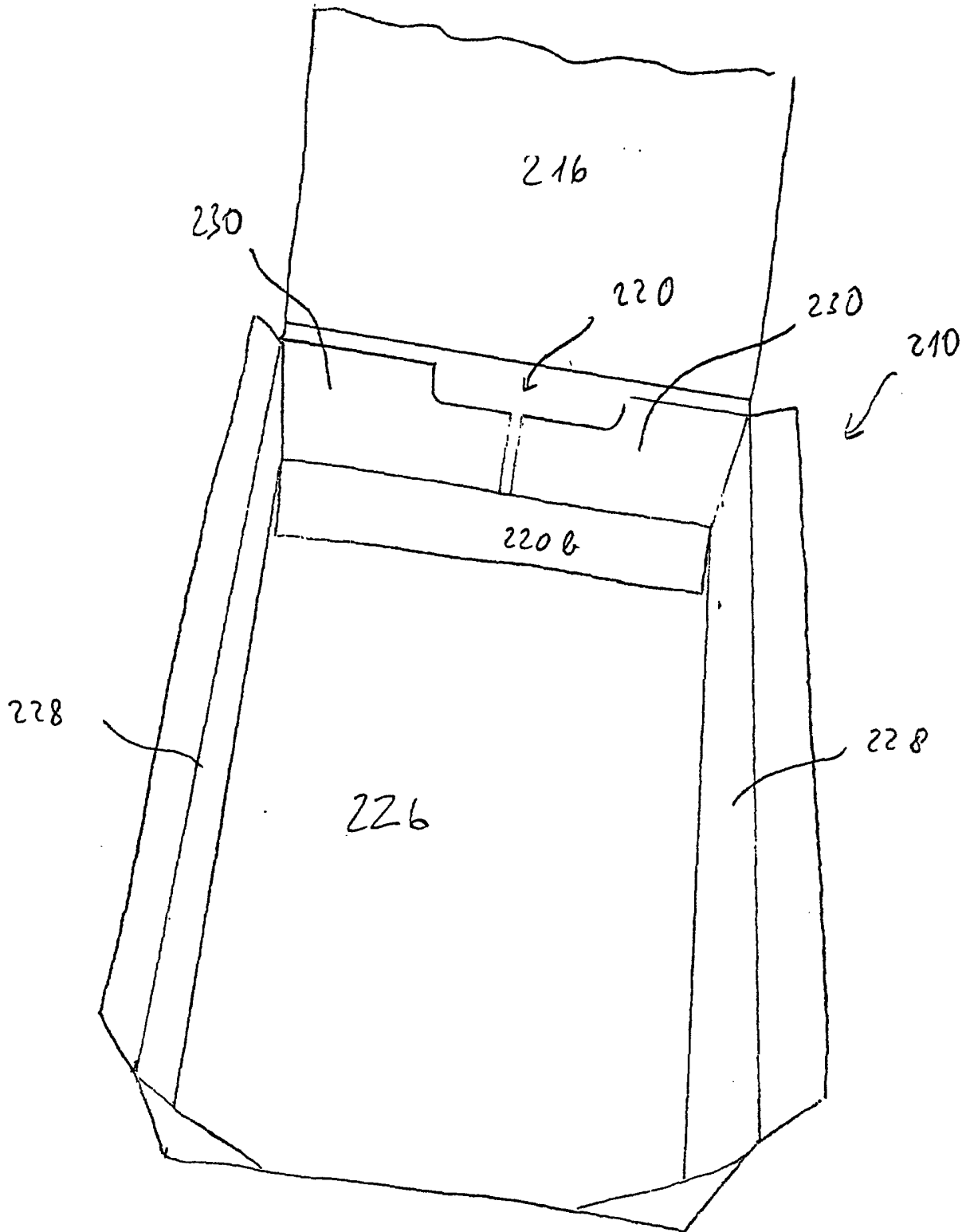

Fig 12