



Europäisches Patentamt  
European Patent Office  
Office européen des brevets



(11) **EP 1 003 187 A3**

(12) **EUROPEAN PATENT APPLICATION**

(88) Date of publication A3:  
**25.09.2002 Bulletin 2002/39**

(51) Int Cl.7: **H01H 13/06, H01H 13/70**

(43) Date of publication A2:  
**24.05.2000 Bulletin 2000/21**

(21) Application number: **99117356.8**

(22) Date of filing: **03.09.1999**

(84) Designated Contracting States:  
**AT BE CH CY DE DK ES FI FR GB GR IE IT LI LU  
MC NL PT SE**  
Designated Extension States:  
**AL LT LV MK RO SI**

(72) Inventor: **Roggero, Gianfranco**  
**15023 Felizzano (Alessandria) (IT)**

(74) Representative: **Cicogna, Franco**  
**Ufficio Internazionale Brevetti**  
**Dott.Prof. Franco Cicogna**  
**Via Visconti di Modrone, 14/A**  
**20122 Milano (IT)**

(30) Priority: **17.11.1998 IT MI980741 U**

(71) Applicant: **Sylea Italia S.r.l.**  
**15023 Felizzano (Alessandria) (IT)**

(54) **Switch template for control switches, in particular for operating electric devices in motor vehicles**

(57) The invention relates to a switch template for control switches, in particular for operating electric devices in motor vehicles, the template comprising a plurality of push-buttons which are operatively coupled to an actuator holding bodies holding therein a plurality of actuators controlled by said push-buttons. The main feature of the invention is that the push-buttons and holding body comprise a single piece made by molding.

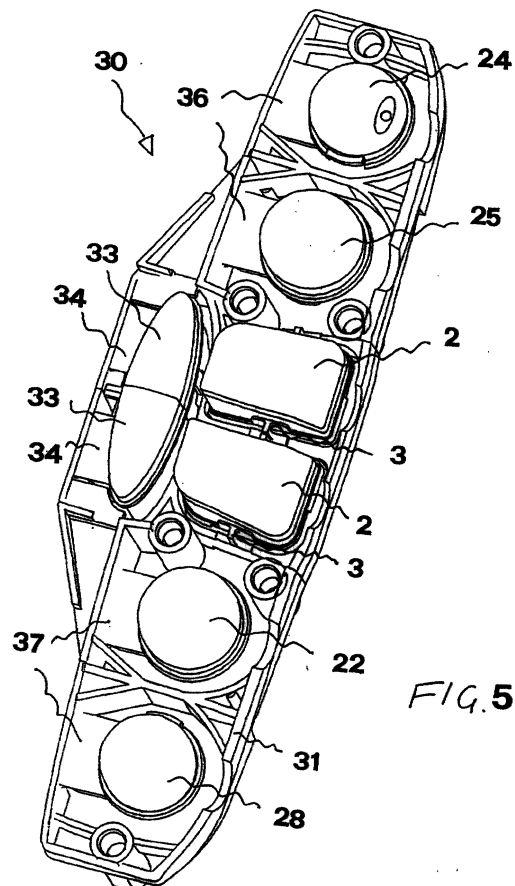

FIG. 5

EP 1 003 187 A3



European Patent  
Office

EUROPEAN SEARCH REPORT

Application Number  
EP 99 11 7356

DOCUMENTS CONSIDERED TO BE RELEVANT			
Category	Citation of document with indication, where appropriate, of relevant passages	Relevant to claim	CLASSIFICATION OF THE APPLICATION (Int.Cl.7)
X	DE 94 02 643 U (MEYRA WILHELM MEYER GMBH & CO) 7 April 1994 (1994-04-07)	1,2	H01H13/06 H01H13/70
A	* the whole document *	3-7	
X	US 4 032 729 A (KOISTINEN CLAYTON W) 28 June 1977 (1977-06-28) * abstract; claims; figures *	1,2	
A	US 4 160 886 A (WRIGHT DECEASED DUANE H ET AL) 10 July 1979 (1979-07-10) * abstract; claims; figure 9 *	1-7	
A	WO 97 50104 A (NATSUDA YOSHIHIRO ; TOKAI RIKA CO LTD (JP); NAGAYA MASAMI (JP); SUZ) 31 December 1997 (1997-12-31) * abstract; figures *	1-7	
A	US 4 323 740 A (BALASH FREDERICK A) 6 April 1982 (1982-04-06) * abstract; claims; figures *	1-7	
The present search report has been drawn up for all claims			TECHNICAL FIELDS SEARCHED (Int.Cl.7)
			H01H
Place of search	Date of completion of the search	Examiner	
THE HAGUE	1 August 2002	Durand, F	
CATEGORY OF CITED DOCUMENTS			
X : particularly relevant if taken alone Y : particularly relevant if combined with another document of the same category A : technological background O : non-written disclosure P : intermediate document		T : theory or principle underlying the invention E : earlier patent document, but published on, or after the filing date D : document cited in the application L : document cited for other reasons & : member of the same patent family, corresponding document	

EPO FORM 1503 03/82 (F04C01)

**ANNEX TO THE EUROPEAN SEARCH REPORT  
ON EUROPEAN PATENT APPLICATION NO.**

EP 99 11 7356

This annex lists the patent family members relating to the patent documents cited in the above-mentioned European search report. The members are as contained in the European Patent Office EDP file on  
The European Patent Office is in no way liable for these particulars which are merely given for the purpose of information.

01-08-2002

Patent document cited in search report	Publication date	Patent family member(s)	Publication date
DE 9402643 U	07-04-1994	DE 9402643 U1	07-04-1994
US 4032729 A	28-06-1977	NONE	
US 4160886 A	10-07-1979	NONE	
WO 9750104 A	31-12-1997	JP 10012089 A WO 9750104 A1	16-01-1998 31-12-1997
US 4323740 A	06-04-1982	BE 887349 A1 CA 1179749 A1 DE 3103768 A1 FR 2475288 A1 GB 2068643 A ,B JP 56123629 A	01-06-1981 18-12-1984 28-01-1982 07-08-1981 12-08-1981 28-09-1981