



Europäisches Patentamt  
European Patent Office  
Office européen des brevets



(11) **EP 1 006 846 B1**

(12) **EUROPEAN PATENT SPECIFICATION**

(45) Date of publication and mention  
of the grant of the patent:

**16.04.2003 Bulletin 2003/16**

(21) Application number: **97911541.7**

(22) Date of filing: **20.10.1997**

(51) Int Cl.7: **A47F 5/11, B65D 5/52**

(86) International application number:  
**PCT/SE97/01751**

(87) International publication number:  
**WO 98/018368 (07.05.1998 Gazette 1998/18)**

(54) **PROTECTIVE COVER WITH INTEGRALLY FORMED DISPLAY STAND**

EINEN EINHEITLICHEN BLOCK MIT EINER PRÄSENTATIONSVORRICHTUNG BILDENDE  
SCHUTZHÜLLE

ENVELOPPE PROTECTRICE FORMANT UN SEUL BLOC AVEC UN PRESENTOIR

(84) Designated Contracting States:  
**AT BE CH DE DK ES FI FR GB GR IE IT LI LU MC  
NL PT SE**

(30) Priority: **29.10.1996 SE 9603939**

(43) Date of publication of application:  
**14.06.2000 Bulletin 2000/24**

(73) Proprietor: **Sca Packaging Display Ab  
601 17 Norrköping (SE)**

(72) Inventor: **ALDEN, Kurt  
S-614 34 Söderköping (SE)**

(74) Representative: **Willquist, Bo  
Willquist & Partners Patentbyrå AB,  
Platensgatan 9 C  
582 20 Linköping (SE)**

(56) References cited:  
**EP-A- 0 327 529 SE-C- 503 957  
US-A- 2 827 162 US-A- 3 190 439  
US-A- 3 240 325 US-A- 4 694 955**

- **MODERN PACKAGING, Sept. 1978, NICHOLAS  
LISTER MOORE, "The Battle of the Shippers",  
page 32.**

**EP 1 006 846 B1**

Note: Within nine months from the publication of the mention of the grant of the European patent, any person may give notice to the European Patent Office of opposition to the European patent granted. Notice of opposition shall be filed in a written reasoned statement. It shall not be deemed to have been filed until the opposition fee has been paid. (Art. 99(1) European Patent Convention).

**Description**

**[0001]** The present invention relates to a protective cover for protecting goods during transport on a loading pallet, the protective cover being manufactured from a stiff, foldable material, preferably corrugated cardboard, as indicated in the precharacterising clause of claim 1.

**[0002]** Conventional protective covers, as disclosed in US 3 240 325 A or US 4 694 955 A, are intended to be used as display stands after transport are often constructed from a number of parts which require time-consuming assembly in order to produce a useable display stand. Display stands of corrugated cardboard produced in this way generally have a very low strength, which makes them unfit to support a load. These have therefore often had to be provided with a framework in order to be able to withstand loading. Protective covers are also known, which are simply provided with a part delineated by a perforation which can be removed in order to display the goods. This type of protective cover is often unsatisfactory, however, both from an aesthetic and from a display point of view. Protective covers of this type are mainly used as display stands in shops, cinemas and showrooms etc.

**[0003]** The object of the present invention is to produce an entirely new type of protective cover, in order to protect goods during transport on a loading pallet, the protective cover having an integrally formed display stand which is easily prepared when opening the protective cover.

**[0004]** The invention is characterised by the specifications given in the characterising parts of the claims.

**[0005]** The protective cover according to the invention has several advantages. The invention produces a protective cover which can easily be converted into a functional display stand suitable for displaying different types of products. The protective cover with integrally formed display stand according to the invention brings savings in both packaging and display material, and in time spent unpacking and getting the display stand ready, and thus ensures low costs for both transport and display of goods. The protective cover with integrally formed display stand according to the invention also leads to reduced quantities of waste, since the same material is used for both the protective cover for transport and the display stand for displaying the goods.

**[0006]** The invention will be explained in more detail below with the aid of examples of preferred embodiments and with reference to the drawings attached, in which:

Fig. 1a shows a first embodiment of the protective cover according to the invention in a transport position.

Fig. 1b shows how the protective cover in fig. 1a is provided with a part which can be folded up for accessing and displaying the goods.

Fig. 1c shows the transport cover according to the invention in fig. 1a converted to a display stand with a very stable, level shelf.

5 Fig. 1d shows how a part of the front of the protective cover in fig. 1a is made to assume an upright position above the display stand shelf which is advantageous from the display point of view.

10 Fig. 2a shows a second embodiment of a protective cover according to the invention in a transport position.

15 Fig. 2b shows how the protective cover in fig. 2a is provided with a part which can be folded up for accessing and displaying the goods.

20 Fig. 2c shows how the flap in 2a, which forms an integral part of the top and is folded in from the front upper edge, is prepared for folding into an edged shelf.

25 Fig. 2d shows the transport cover according to the invention in fig. 2a converted to a display stand with an edged shelf.

30 Fig. 2e shows how a part of the front of the protective cover in fig. 2a is made to assume an upright position above the display stand shelf which is advantageous from the display point of view.

35 **[0007]** For identical or similar details the same reference designations are used in describing both embodiments.

40 **[0008]** Fig. 1a shows a first embodiment of a protective cover 1 according to the invention in a transport position. In this position it is intended to protect the goods during transport on a loading pallet. The protective cover 1 is manufactured from a stiff, foldable material, preferably corrugated cardboard. It has a front face, a rear face, two opposing sides and a top formed from flaps folded in from the upper edges of the front and rear face and the sides respectively. The protective cover 1 may be provided with printed advertising matter and/or trade mark of the contents (not shown). This printed advertising matter/trademark may, for example, be given on the front face of the protective cover.

50 **[0009]** For accessing and displaying the goods, the protective cover 1, as shown in fig. 1b, is provided with a part 4 which can be folded up about a first score/groove 11. This part is delineated partly by the first score/groove 11, which runs between the top edges facing the sides and essentially parallel with the top front-facing edge, and partly by a first perforation 2, which connects the respective ends of the first score/groove and runs over the sides towards their front-facing edges

and from these on over the front face.

**[0010]** There is a second score/groove 12 essentially parallel to the first score/groove 11. These scores/grooves are arranged at a distance from one another which exceeds the thickness of the material and preferably in the order of 1-5 cm. The ends of the scores/grooves converge on one another at each side respectively, and specifically within an area of 2 to 10 cm from each side, preferably 5 cm.

**[0011]** That part 4 of the protective covering which can be folded up is also provided with a second perforation 3, which begins and ends at an imaginary line opposite its front face parallel with its edge facing the top. This second perforation 3 together with the imaginary line delineates a surface towards the top of its front face. This surface is especially suited for the printed advertising matter/trademark. Seventh scores/grooves 17, which round the corners to the sides and continue at the same height to the first perforation 2, run along the imaginary line from the start and end of the second perforation and out towards the front side-facing edges. On each side there is a further eighth score/groove 18, which runs between the respective points of intersection of the seventh scores/grooves with the side front-facing edges and form angles with the seventh score/groove 17 and run on down to the first perforation 2.

**[0012]** The front of the protective cover is provided, in connection with the first perforation 2, with at least one notch 5, designed to allow the first perforation 2 to be broken and the foldable part 4 of the protective cover to be folded up.

**[0013]** Fig. 1c shows the first embodiment of the protective cover 1 according to the invention converted to a display stand with a very stable, flat shelf 6. In order to perform this conversion, the first perforation 2 is first broken by grasping the foldable part 4 of the protective cover with the aid of the notch 5 (fig. 1a), The foldable part 4 is then folded upwards about the first and second scores/grooves 11, 12 as shown in fig. 1b, so that the top front-facing edge rests against the top in the area of its rear-facing edge. Because the first and second scores/grooves 11, 12 are arranged at a distance from one another which exceeds the thickness of the material and their ends converge on one another at each side, the display stand thereby produced has a very stable level shelf 6 formed by the top. This shelf 6 is very suitable for displaying goods. Even relatively heavy goods can be displayed on this shelf 6 without undesirable sagging or deformation thereof.

**[0014]** The printed advertising matter/trademark located, for example, on the front of the protective cover during transport, will now be found inverted in the folded-up part 4 at the top of the rear of the protective cover. Because the advertising matter/trademark has been placed on the surface which is delineated by the second perforation 3 and the imaginary line, which constitutes a continuation of the seventh scores/grooves 17, this can now be made to assume a position as in fig. 1d,

advantageous from a display point of view, upright above the shelf of the display stand 6, by breaking the second perforation 3 and folding the upper part of the display stand forward essentially 180° about the seventh scores/grooves 17. The eighth scores/grooves 18 then prevent the display stand from being unaesthetically deformed whilst at the same time permitting this folding operation.

**[0015]** Fig. 2a shows a second embodiment of a protective cover 1' according to the invention in the transport position. In this position this protective cover 1' is intended to protect goods during transport on a loading pallet in the same way as the protective cover 1 according to the first embodiment. The protective cover 1' is likewise manufactured from a stiff, foldable material, preferably corrugated cardboard. This protective cover 1' also has a front face, a rear face, two opposing sides and a top formed from flaps folded in from the upper edges of front and rear faces and the sides respectively. The protective cover 1' according to this embodiment can also be provided with printed advertising matter and/or the trademark of the contents (not shown), for example on the front face of the protective cover.

**[0016]** For accessing and displaying the goods, the protective cover 1' as shown in fig. 2b is provided with a part 4 which can be folded up about a first score/groove 11. This part is delineated in the same way as for the first embodiment. The first score/groove 11, however, about which the material on one side of the score/groove is designed to be folded, so as to rest against the material on the second side of the score/groove, is executed as two parallel scores/grooves, their distance from one another being essentially equal to the thickness of the material.

**[0017]** As can be seen from fig. 2c, the flap 7, forming an integral part of the top and folded in from the front upper edge has a free edge 8, which is essentially parallel to the top front-facing edge, and two opposing side edges, which are essentially parallel to the top side-facing edges. The flap 7 is also provided with third and fourth scores/grooves 13, 14 parallel to on another, which run parallel to its free edge 8 and with essentially the same distance between this edge and the third score/groove 13 as between the third and fourth scores/grooves 13, 14. The side edges of the flap are each provided with folding flaps 19. These are delineated at the side edges of the flap by fifth scores/grooves 15 and each have sixth scores/grooves 16 which extend the fourth scores/grooves 14 out on the folding flaps 19. The folding flaps 19 are cut free along the side edges of the flap from the fourth score/groove 14 and out to the free edge 8 of the flap. At its free edge 8 the flap 7 has at least one projecting section 20, which corresponds to a first notch 21 made in connection with the fourth score/groove 14.

**[0018]** In the same way as the protective cover 1 according to the first embodiment, the foldable part 4 of the protective cover is provided with a second perfora-

tion 3, seventh scores/grooves 17 along the imaginary line and a further eighth score/groove 18 on each side.

[0019] Fig. 2d shows the second embodiment of the protective cover 1' according to the invention converted to a display stand with an edged shelf 6. In order to perform this conversion, the first perforation 2 is first broken by grasping the foldable part 4 of the protective cover with the aid of the notch 5 (fig. 1). The foldable part 4 is then folded up about the first score/groove 11 as shown in fig. 2b, so that the associated part of the top rests against the remaining part of the top. Because the first score/groove 11, about which the material on one side of the score/groove is designed to be folded so as to rest against the material on the second side of the score/groove, is executed as two parallel scores/grooves, their distance from one another being essentially equal to the thickness of the material, this reduces the tendency of the material to try to return to the original unfolded position.

[0020] The flap 7, forming an integral part of the top and folded in from the front upper edge, can be converted to an edged shelf 6 as shown in fig. 2d. This is done in the proper order by first folding the folding flaps 19 about the fifth scores/grooves 15, so that these essentially form a right angle with the flap 7, and then folding the free-cut sections of the folding flaps about the respective seventh score/groove 16, so that these point towards one another along the fourth score/groove 14, and then folding the free end about the third and fourth scores/grooves 13, 14, so that this part of the flap 7 encloses the free-cut sections of the folding flaps and the projecting section 20 is brought into engagement with the first notch 21. This shelf 6 is very suitable for the display of goods. Even goods which tend to roll or can otherwise be easily made to move on the shelf 6 can, because of the edge, be displayed on this shelf 6 without the risk of accidentally falling off it. Because the third score/groove 13, about which the material is designed to be folded so that it encloses the free-cut sections of the folding flaps, is executed as two parallel scores/grooves, their distance from one another being essentially equal to the thickness of the intermediate material, this reduces the tendency of the material to try to return to its original unfolded position.

[0021] The trademark (not shown) located, for example, on the front of the protective cover during transport, will now, as shown in fig. 2d, be found inverted on the folded-up part 4 at the top of the rear of the protective cover. Because the printed advertising matter/trademark has been paced on the surface which is delineated by the second perforation 3 and the imaginary line, which constitutes a continuation of the seventh scores/grooves 17, this can now be made to assume the position as in fig. 2e, advantageous from a display point of view, in the same way as for the first embodiment.

[0022] Further scores/grooves, about which the material on one side of the score/groove is designed to be folded so as to rest against the material on the second

side of the score/groove, are also preferably executed as two parallel scores/grooves, the distance from one another being essentially equal to the thickness of the material.

[0023] It will be obvious to a person skilled in the art that the invention is not confined to the embodiments described above, but rather lends itself to modifications within the framework of the idea of the invention defined in the claims below.

## Claims

1. Protective cover (1, 1') for protecting goods during transport on a loading pallet, the protective cover (1, 1') being manufactured from a stiff, foldable material, preferably corrugated cardboard and having a front face, a rear face, two opposing sides and a top formed from flaps folded in from the upper edges of the front and rear face and the sides respectively, in which for accessing and displaying the goods the protective cover (1, 1') is provided with a part (4) which can be folded up about a first score/groove (11) and is delineated partly by the first score/groove (11), which runs between the top side-facing edges and essentially parallel with the top front-facing edge, and partly by a first perforation 2, which connects the respective ends of the first score/groove and runs over the sides towards their front-facing edges and from these on over the front face, **characterised in that** the foldable part (4) of the protective cover is provided with a second perforation (3) which begins and ends at an imaginary line opposite its front face parallel with its top-facing edge and which second perforation (3) together with the imaginary line delineates a surface towards the top of its front face, and that seventh scores/grooves (17), which round the corners to the sides and continue at the same height to the first perforation (2), run along the imaginary line from the start and end of the second perforation and out towards the front side-facing edges, and that on each side there is a further eighth score/groove (18), which runs between the respective points of intersection of the seventh scores/grooves with the front-facing edges of the sides and form angles with the seventh score/groove (17) and run on down to the first perforation (2).
2. Protective cover (1, 1') according to claim 1, **characterised in that** there is a second score/groove (12) essentially parallel to the first score/groove (11), the scores/grooves being arranged at a distance from one another which exceeds the thickness of the material and their ends converging on one another at each side respectively.
3. Protective cover (1, 1') according to claim 1, **char-**

**acterised in that** the flap (7), forming an integral part of the top and folded in from the front upper edge has a free edge (8), which is essentially parallel to the top front-facing edge, and two opposing side edges, which are essentially parallel to the top side-facing edges, the flap (7) being provided with third and fourth parallel scores/grooves (13, 14) which run parallel to the free edge (8) of the flap and with essentially the same distance between this edge and the third score/groove (13) as between the third and fourth scores/grooves (13, 14) and that the side edges of the flap are each provided with folding flaps (19), which are delineated at the side edges of the flap by fifth scores/grooves (15) and each have sixth scores/grooves (16) which extend the fourth score/groove (14) out on the folding flaps (19), which folding flaps (19) are cut free along the side edges of the flap from the fourth score/groove (14) and out to the free edge (8) of the flap, and that at its free edge (8) the flap (7) has at least one projecting section (20), which corresponds to a first notch (21) made in connection with the fourth score/groove (14).

4. Protective cover (1, 1') according to any of claims 1 to 3, **characterised in that** the scores/grooves, about which the material on one side of the score/groove is designed to be folded so as to rest against the material on the second side of the score/groove, is executed as two parallel scores/grooves, the distance from one another being essentially equal to the thickness of the material.
5. Protective cover (1, 1') according to any of claims 1 to 4, **characterised in that** the front in connection with the first perforation (2) is provided with at least one notch (5), designed to allow the first perforation (2) to be broken and the foldable part (4) of the protective cover to be folded up.

#### Patentansprüche

1. Schutzabdeckung (1, 1') zum Schützen von Waren während des Transports auf einer Ladepalette, wobei die Schutzabdeckung (1, 1') aus einem steifen faltbaren Material, vorzugsweise Wellpappe, hergestellt ist und eine Vorderseite, eine Rückseite, zwei gegenüberliegende Seiten und ein aus Klappen gebildetes Oberteil aufweist, das nach innen von den oberen Rändern der Vorder- und Rückseiten und den Seiten jeweils eingefaltet ist, in denen für den Zugriff auf und der Anzeige von Waren die Schutzabdeckung (1, 1') mit einem Teil (4) versehen ist, das nach oben um eine erste Kerbe/Rille (11) gefaltet werden kann, und teilweise durch die erste Kerbe/Rille (11), die zwischen den der oberen Seite gegenüberliegenden Rändern und im wesentlichen

parallel mit dem oberen, der Vorderseite gegenüberliegenden Rand läuft, und teilweise durch eine erste Perforation (2), die die jeweiligen Enden der ersten Kerbe/Rille verbindet und über die Seiten zu ihren der Vorderseite gegenüberliegenden Rändern und von diesen weiter über die Vorderseite läuft, festgelegt wird, **dadurch gekennzeichnet, dass** der faltbare Teil (4) der Schutzabdeckung mit einer zweiten Perforation (3) versehen ist, die an einer imaginären Linie beginnt und endet, die entgegengesetzt ihrer Vorderseite parallel mit ihrer dem Oberteil gegenüberliegenden Rand läuft, und wobei die zweite Perforation (3) zusammen mit der imaginären Linie eine Oberfläche nach oben zu ihrer Vorderseite hin festlegt, und dass siebente Kerben/Rillen (17), die um die Ecken an den Seiten gehen und auf der gleichen Höhe zu der ersten Perforation (2) weitergehen, entlang der imaginären Linie vom Anfang und Ende der zweiten Perforation und zu den der Vorderseite gegenüberliegenden Rändern hin laufen, und dass an jeder Seite es eine weitere achte Kerbe/Rille (18) gibt, die zwischen den jeweiligen Punkten der Kreuzung der siebenten Kerben/Rillen mit den der Vorderseite gegenüberliegenden Rändern der Seiten läuft und Winkel mit der siebten Kerbe/Rille (17) bildet und weiter zu der ersten Perforation (2) hinunter läuft.

2. Schutzabdeckung (1, 1') gemäß Anspruch 1, **dadurch gekennzeichnet, dass** es eine zweite Kerbe/Rille (12) gibt, die im wesentlichen zu der ersten Kerbe/Rille (11) parallel ist, wobei die Kerben/Rillen an einem Abstand voneinander angeordnet sind, der die Dicke des Materials überschreitet, und ihre Enden an jeder Seite jeweils aufeinander zusammenlaufen.
3. Schutzabdeckung (1, 1') gemäß Anspruch 1, **dadurch gekennzeichnet, dass** die Klappe (7), die ein integrales Bestandteil des Oberteils bildet und von dem vorderen oberen Rand nach innen gefaltet ist, einen freien Rand (8), der mit dem oberen, der Vorderseite gegenüberliegenden Rand im wesentlichen parallel ist, und zwei entgegengesetzte Seitenränder, die im wesentlichen mit den oberen den Seiten gegenüberliegenden Rändern parallel sind, aufweist, wobei die Klappe (7) mit dritten und vierten parallelen Kerben/Rillen (13, 14) versehen ist, die zu dem freien Rand (8) der Klappe parallel und mit im wesentlichen dem gleichen Abstand zwischen diesem Rand und der dritten Kerbe/Rille (13) wie zwischen den dritten und vierten Kerben/Rillen (13, 14) laufen, und dass die Seitenränder der Klappe jeweils mit Faltklappen (19) versehen sind, die an den Seitenrändern der Klappe durch fünfte Kerben/Rillen (15) festgelegt werden und jeweils sechste Kerben/Rillen (16) aufweisen, die die vierte Kerbe/Rille (14) hinaus zu den Faltklappen (19) verlän-

gern, wobei die Faltklappen (19) entlang den Seitenrändern der Klappe von der vierten Kerbe/Rille (14) und hinaus zu dem freien Rand (8) der Klappe freigeschnitten sind, und dass die Klappe (7) an ihrem freien Rand (8) mindestens eine hervorstehende Aussparung (20) aufweist, die einer ersten Kerbe (21) entspricht, die in Verbindung mit der vierten Kerbe/Rille (14) ausgeführt wurde.

4. Schutzabdeckung (1, 1') gemäß einem der Ansprüche 1 bis 3, **dadurch gekennzeichnet, dass** die Kerben/Rillen, um die das Material an einer Seite der Kerbe/Rille ausgestaltet ist, um gefaltet zu werden, um gegen das Material an der zweiten Seite der Kerbe/Rille anzuliegen, als zwei parallele Kerben/Rillen ausgeführt sind, wobei der Abstand voneinander im wesentlichen gleich der Dicke des Materials ist.
5. Schutzabdeckung (1, 1') gemäß einem der Ansprüche 1 bis 4, **dadurch gekennzeichnet, dass** die Vorderseite in Verbindung mit der ersten Perforation (2) mit mindestens einer Aussparung (5) versehen ist, die ausgestaltet ist, um zu ermöglichen, dass die erste Perforation (2) gebrochen und dass der faltbare Teil (4) der Schutzabdeckung nach oben gefaltet werden kann.

#### Revendications

1. Enveloppe protectrice (1, 1') pour protéger des marchandises pendant le transport sur une palette de chargement, l'enveloppe protectrice (1, 1') étant fabriquée en une matière rigide pliable, de préférence du carton ondulé, et ayant une face avant, une face arrière, deux côtés opposés et un sommet constitué de rabats pliés vers l'intérieur à partir des bords supérieurs des faces avant et arrière et des côtés respectivement, dans laquelle, pour accéder aux marchandises et les présenter, l'enveloppe protectrice (1, 1') comprend une partie (4) qui peut être rabattue vers le haut autour d'une première marque / rainure (11) et qui est délimitée en partie par la première marque / rainure (11), qui s'étend entre les bords latéraux supérieurs et sensiblement parallèlement au bord supérieur avant, et en partie par une première entaille (2) qui relie les extrémités respectives de la première marque / rainure et s'étend sur les côtés vers leurs bords avant et, à partir de ces derniers, sur toute la face avant, **caractérisée en ce que** la partie rabattable (4) de l'enveloppe protectrice comporte une deuxième entaille (3) qui commence et se termine sur une ligne imaginaire située du côté opposé de sa face avant et parallèle à son bord supérieur et cette deuxième entaille (3), en combinaison avec la ligne imaginaire, délimite une surface vers le sommet de sa face avant, et **en ce que** des septièmes marques / rainures (17), qui contournent les angles vers les côtés et se poursuivent à la même hauteur jusqu'à la première entaille (2), s'étendent le long de la ligne imaginaire à partir du début et de la fin de la deuxième entaille et vers les bords latéraux avant, et **en ce que**, de chaque côté, une huitième marque / rainure (18) s'étend entre les points respectifs d'intersection des septièmes marques / rainures avec les bords avant des côtés, et forme un angle avec la septième marque / rainure (17) et s'étend ensuite vers le bas jusqu'à la première entaille (2).
2. Enveloppe protectrice (1, 1') selon la revendication 1, **caractérisée en ce qu'**une deuxième marque / rainure (12) sensiblement parallèle à la première marque / rainure (11) est prévue, les marques / rainures étant disposées à une distance l'une de l'autre qui est supérieure à l'épaisseur de la matière, et leurs extrémités convergent respectivement l'une vers l'autre de chaque côté.
3. Enveloppe protectrice (1, 1') selon la revendication 1, **caractérisée en ce que** le rabat (7), faisant partie intégrante du sommet et plié vers l'intérieur à partir du bord supérieur avant, présente un bord libre (8) qui est sensiblement parallèle au bord supérieur avant et deux bords latéraux opposés qui sont sensiblement parallèles aux bords latéraux supérieurs, le rabat (7) comportant une troisième et une quatrième marques / rainures parallèles (13, 14) qui s'étendent parallèlement au bord libre (8) du rabat et la distance entre ce bord et la troisième marque / rainure (13) est sensiblement la même qu'entre les troisième et quatrième marques / rainures (13, 14), **en ce que** les bords latéraux du rabat comportent chacun des rabats pliés (19) qui sont délimités à l'endroit des bords latéraux du rabat par des cinquièmes marques / rainures (15) et comportant chacun des sixièmes marques / rainures (16) qui prolongent la quatrième marque / rainure (14) à l'extérieur sur les rabats pliés (19), ces rabats pliés (19) étant incisés le long des bords latéraux du rabat à partir de la quatrième marque / rainure (14) et vers l'extérieur jusqu'au bord libre (8) du rabat, et **en ce que**, à son bord libre (8), le rabat (7) comporte au moins une partie en saillie (20) qui correspond à une première encoche (21) effectuée en relation avec la quatrième marque / rainure (14).
4. Enveloppe protectrice (1, 1') selon une quelconque des revendications 1 à 3, **caractérisée en ce que** les marques / rainures, autour desquelles la matière située sur un premier côté de la marque / rainure doit être pliée de façon à reposer contre la matière située du deuxième côté de la marque / rainure, se présentent sous la forme de deux marques / rainures parallèles, la distance de l'une à l'autre étant

sensiblement égale à l'épaisseur de la matière.

5. Enveloppe protectrice (1, 1') selon une quelconque des revendications 1 à 4, **caractérisée en ce que** sa face avant, en relation avec la première ligne de perforations (2), comporte au moins une encoche (5), conçue pour permettre de briser la première entaille (2) et de rabattre vers le haut la partie pliable (4) de l'enveloppe protectrice.

10

15

20

25

30

35

40

45

50

55

Fig. 1a

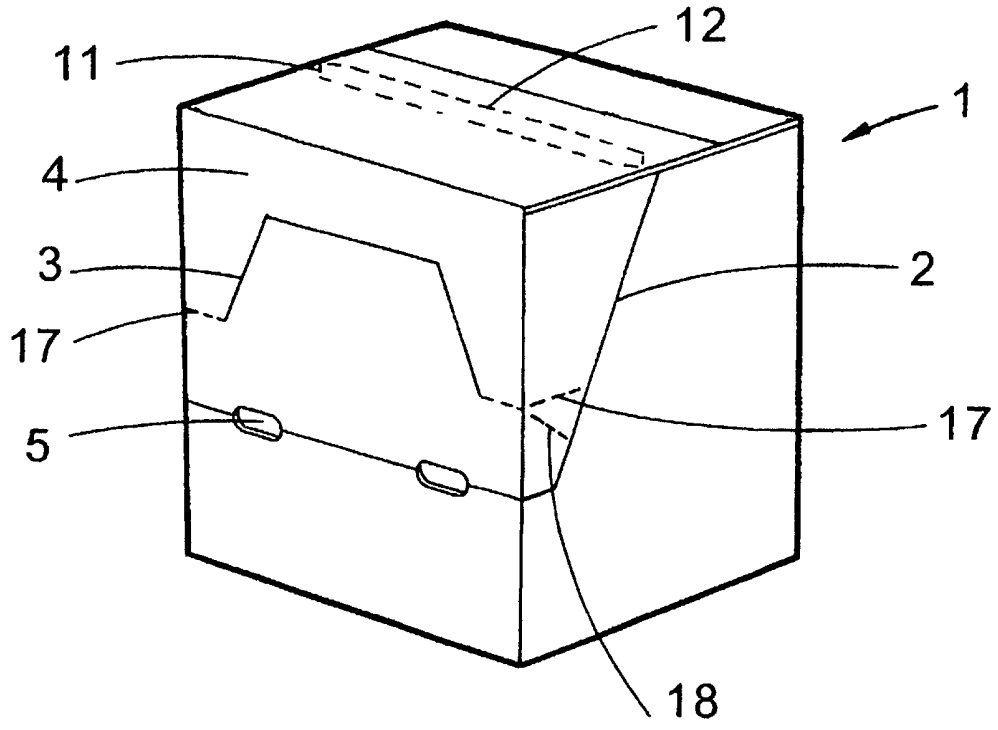

Fig. 1b

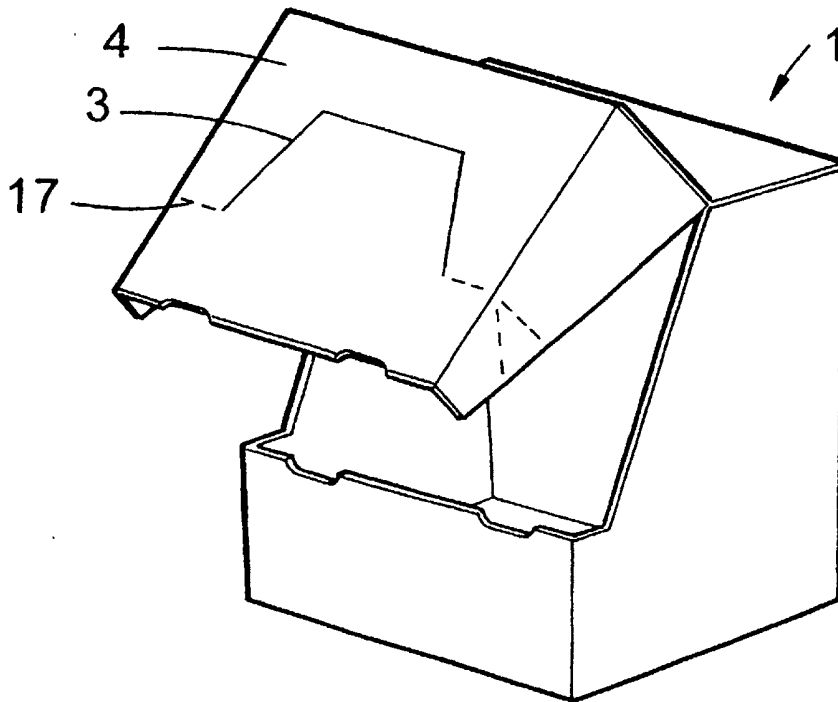



Fig. 1c

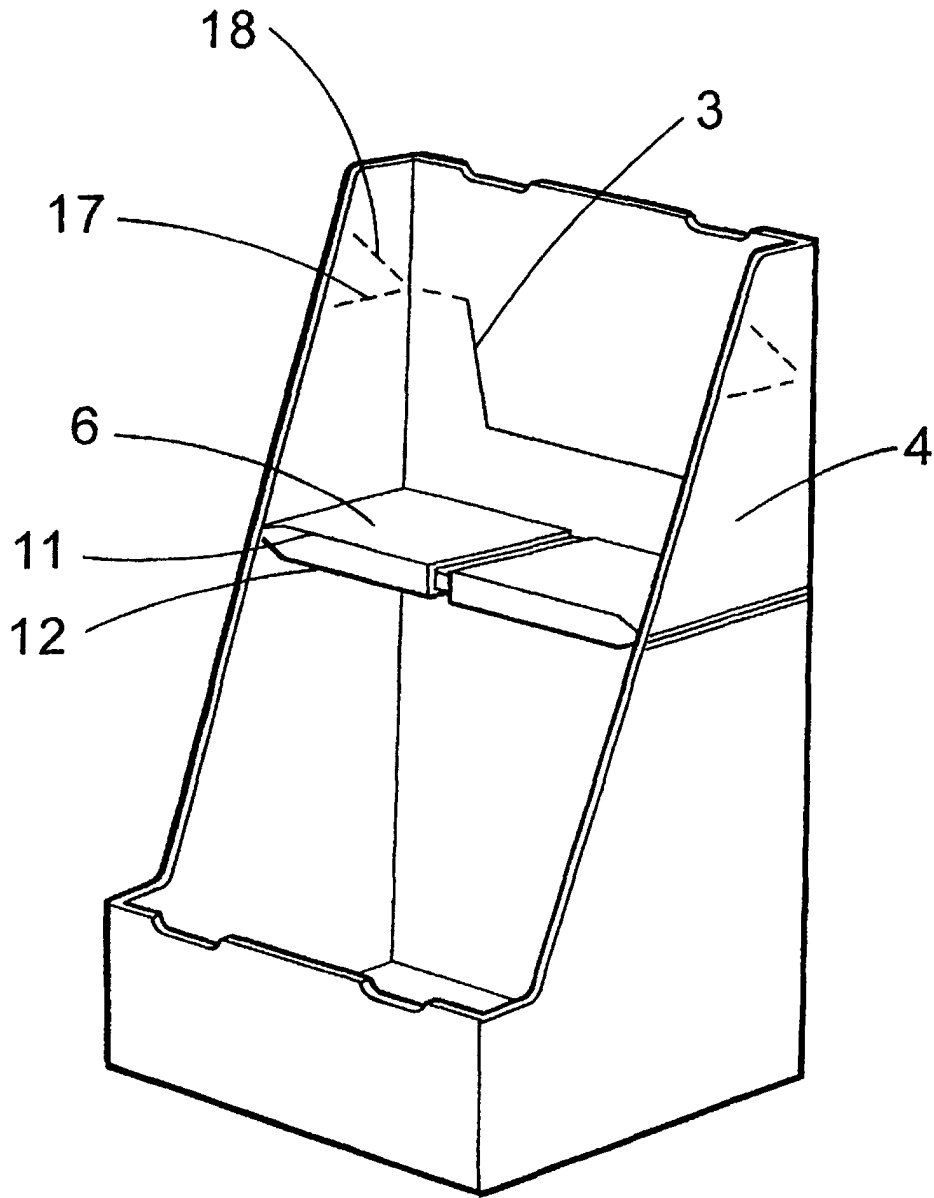

Fig.1d

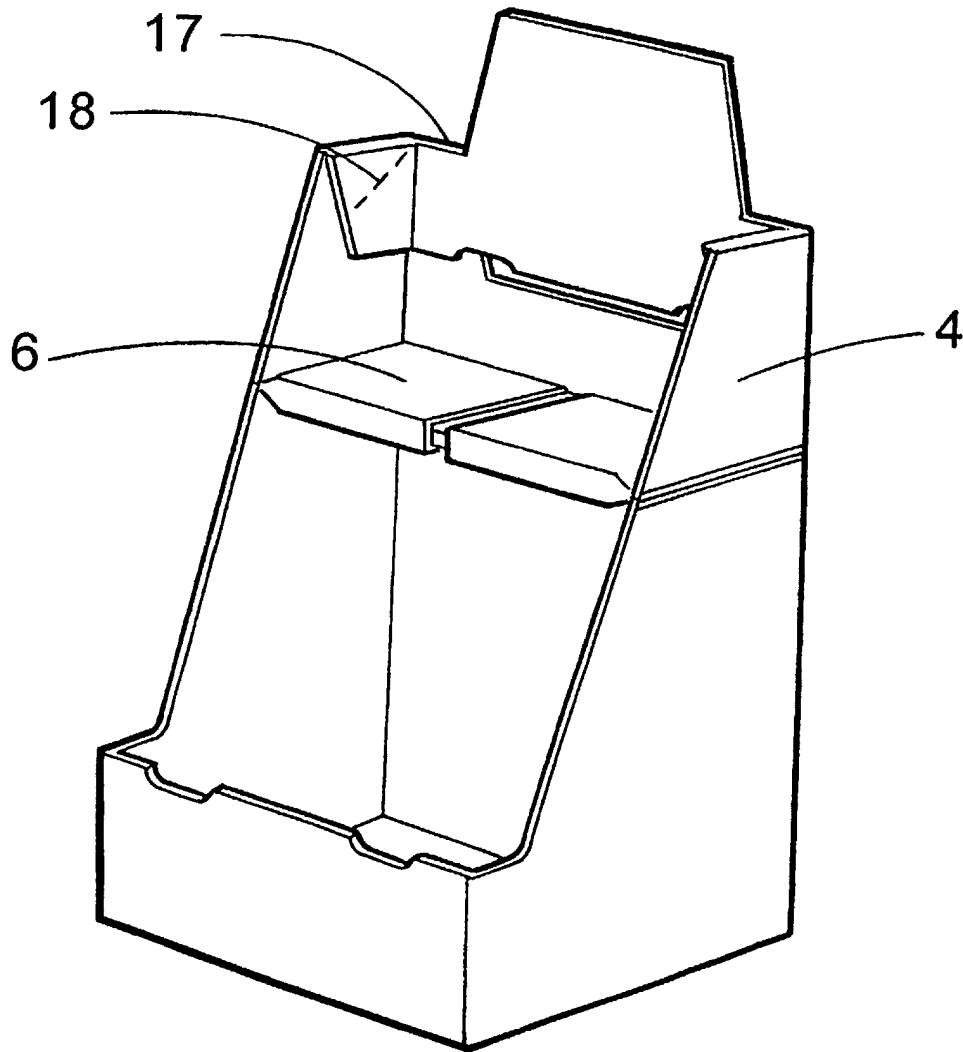

Fig.2a

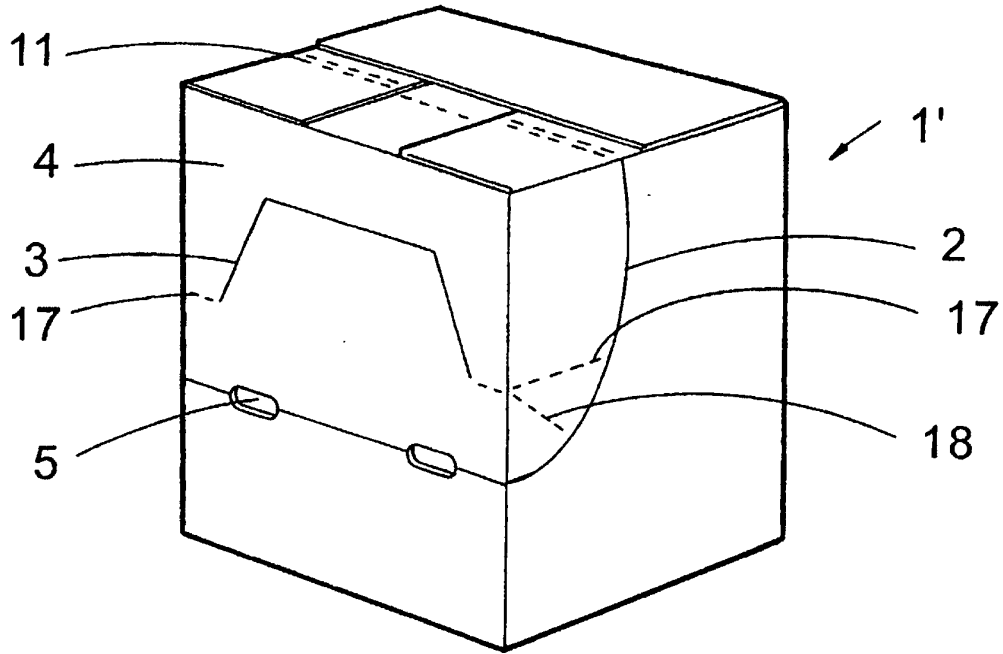

Fig.2b

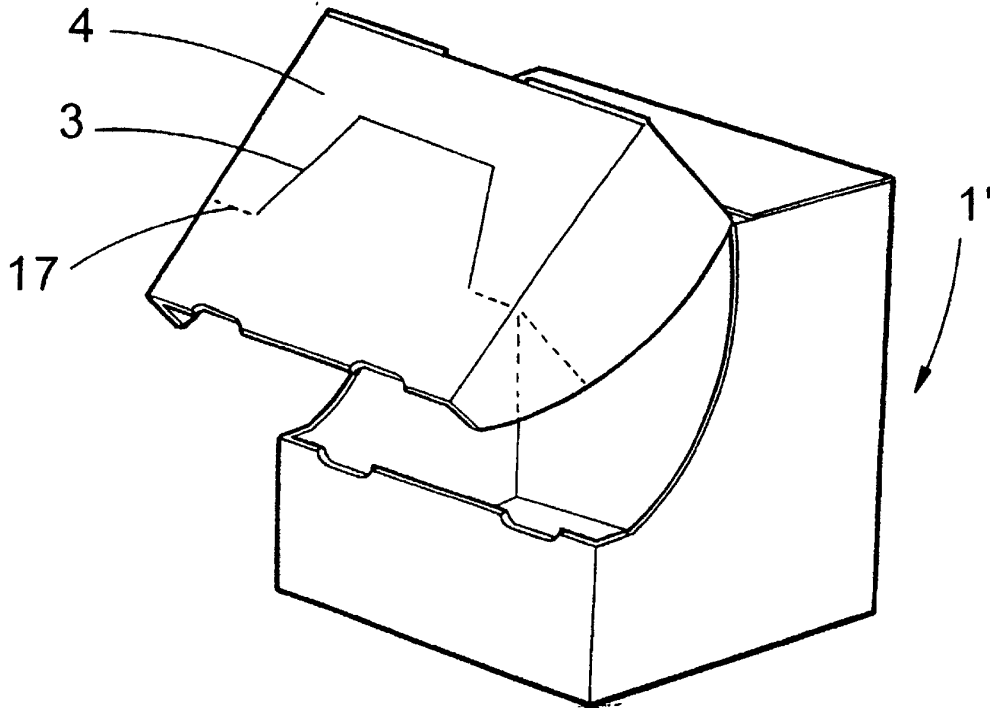

Fig.2c

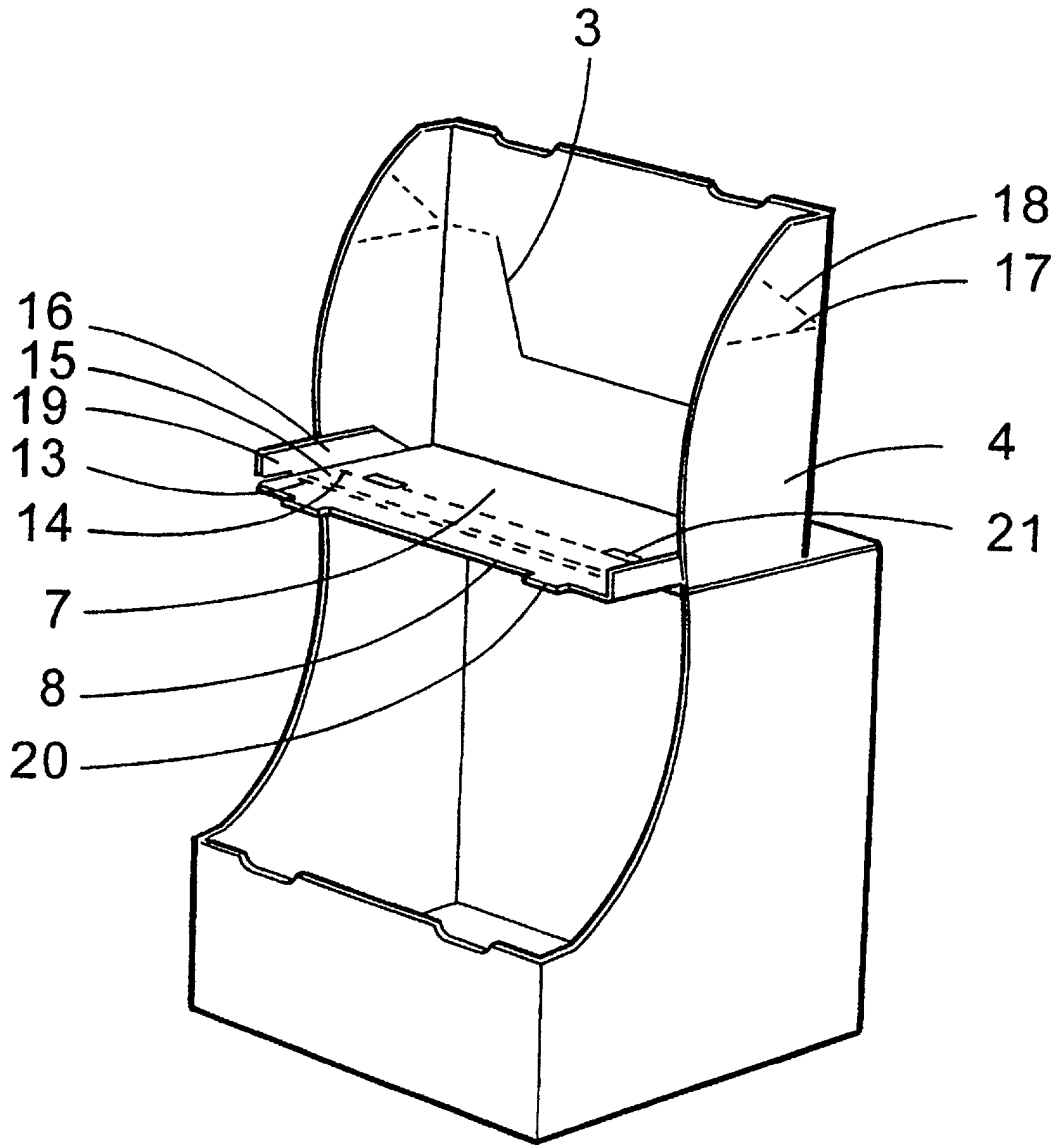

Fig.2d

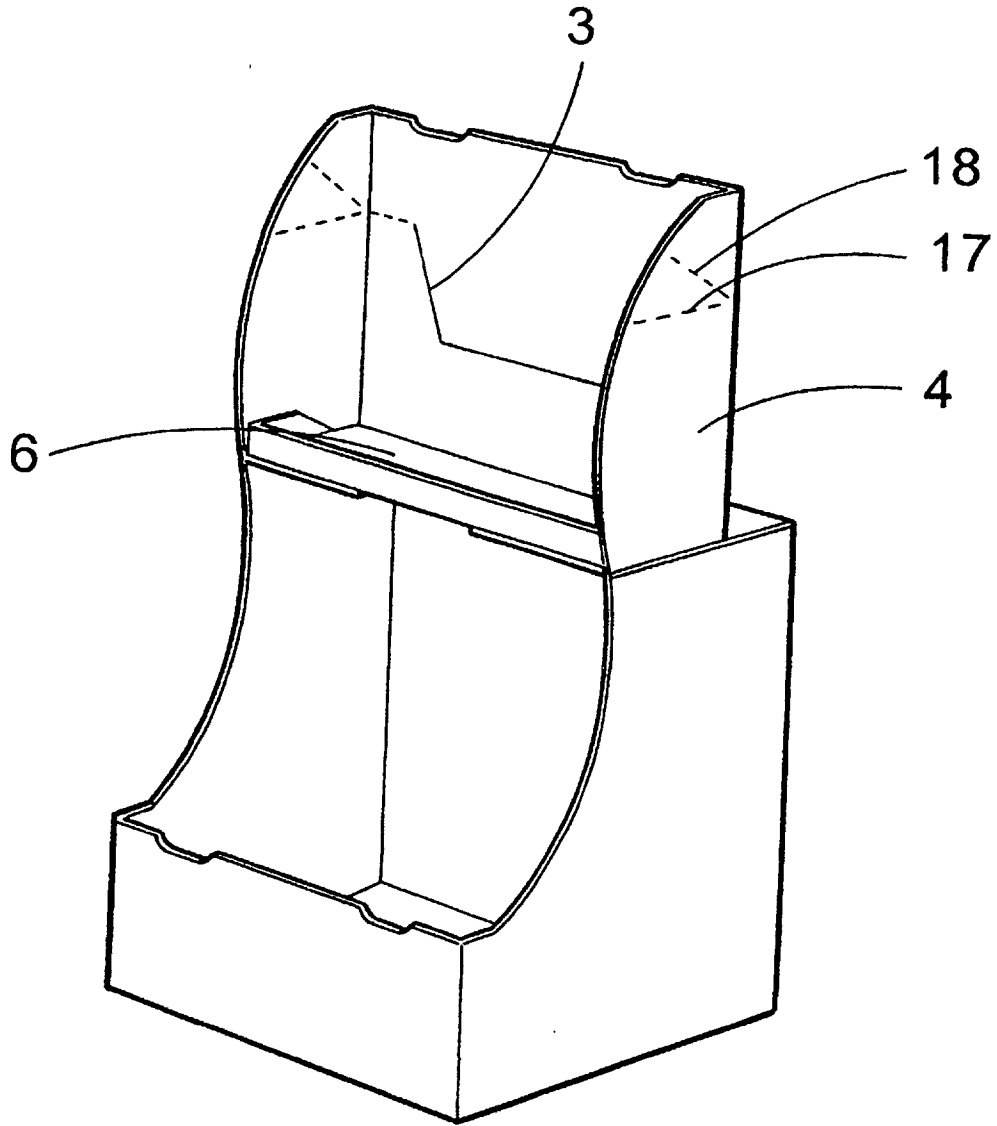

Fig.2e

