



Europäisches Patentamt
European Patent Office
Office européen des brevets



(11) **EP 1 034 823 B1**

(12) **EUROPEAN PATENT SPECIFICATION**

(45) Date of publication and mention
of the grant of the patent:
27.07.2005 Bulletin 2005/30

(51) Int Cl.7: **A63G 31/16**

(21) Application number: **00200632.8**

(22) Date of filing: **24.02.2000**

(54) **Amusement machine with movable seat**

Spielgerät mit beweglichem Sitz

Appareil de divertissement avec siège mobile

(84) Designated Contracting States:
**AT BE CH CY DE DK ES FI FR GB GR IE IT LI LU
MC NL PT SE**
Designated Extension States:
AL RO

(30) Priority: **09.03.1999 IT RE990030**

(43) Date of publication of application:
13.09.2000 Bulletin 2000/37

(73) Proprietor: **Memo-Park Di Incerti Fornaciari
Bruno E C. S.A.S.
42010 Mancasale (Reggio Emilia) - Italy (IT)**

(72) Inventors:
• **Incerti Fornaciari, Bruno
MEMO-PARK DI INCERTI
42010 Mancasale (Reggio Emilia) (IT)**
• **Franchini, Mauro
MEMO-PARK DI FORNACIARI BRUNO E.C
42010 Mancasale (Reggio Emilia) (IT)**

(74) Representative: **Corradini, Corrado et al
Studio Ing. C. CORRADINI & C. S.r.l.
4, Via Dante Alighieri
42100 Reggio Emilia (IT)**

(56) References cited:
**FR-A- 2 618 690 US-A- 2 896 947
US-A- 3 137 500 US-A- 5 364 271**

EP 1 034 823 B1

Note: Within nine months from the publication of the mention of the grant of the European patent, any person may give notice to the European Patent Office of opposition to the European patent granted. Notice of opposition shall be filed in a written reasoned statement. It shall not be deemed to have been filed until the opposition fee has been paid. (Art. 99(1) European Patent Convention).

Description

[0001] This invention relates to an amusement machine comprising at least one movable seat having typically a pleasing and captivating form (for example having the form of a vehicle), carried by a movable structure arranged to movingly transport a child (or a user generally), and mover means for moving the movable structure.

[0002] Other amusement devices have been developed, for example US-A-5364271, which discloses a bicycle simulator.

[0003] An object of the invention is to provide a machine of the stated type, in which the user can interact with the seat movement to derive amusement or pleasure therefrom.

[0004] This and further objects are attained by the invention as characterised in the claims.

[0005] The invention provides an amusement machine having, applied to the seat, a crank mechanism to be operated by the muscular force of the child, and a control system for the machine movements which is able to vary one or more characteristics of the seat movement in a manner correlated with the speed with which the crank mechanism is operated by the child seated on the seat.

[0006] Specifically, said crank mechanism comprises a wheel or other rotary body rotated by the action of the child on the crank mechanism, the control system comprising means for measuring the rotational speed of said wheel or rotary body, and a controlling microprocessor connected to said measurement means to vary, via inverter means, characteristics of the seat movement in a manner correlated with the speed with which the crank mechanism is rotated.

[0007] The seat also comprises a pedalled crank which operates said wheel, and is operated by the legs of the child carried by the seat.

[0008] The invention is described in detail hereinafter with the aid of the accompanying figures, which illustrate a non-exclusive embodiment thereof.

Figure 1 is a general perspective view of the machine of the invention.

Figure 2 is a vertical side elevation of Figure 1.

Figure 3 is a rear facing view of the rear part of the machine of Figure 1.

Figure 4 is a sectional detail of the machine, regarding the crank mechanism applied to the movable seat.

Figure 5 is a general scheme of the machine control system and of the system for operating the seat raising means.

[0009] The machine comprises a movable seat, on which the child sits via a seating portion 11, in such a manner as to be movably transported with it. This seat preferably has a form which is pleasurable and attractive for the child, for example the form of a vehicle driving seat.

[0010] The seat 10 is carried by a movable structure 20 able to movingly transport a child, and with which mover means for moving the structure 20 are associated.

[0011] In the embodiment shown in the figures, there is provided a fixed base 15 comprising an annularly extending rail 16 which rests on the ground. The rail 16 supports a movable base 21 provided with idle wheels which roll along the rail 16. While rolling along the rail 16, the movable base 21 is constrained to rotate about a vertical axis A by means of a vertical pin 22 fixed to the centre of the base 21 and coupled to a bush 17 rigid with the fixed base 15.

[0012] The movable base 21 is connected to mover means for rotating the base 21 about the axis A. In detail, the movable base 21 carries a geared motor 23 which operates a sprocket 24 connected by a transmission chain 25 to a sprocket 26 of vertical axis fixed to the bush 17.

[0013] The movable base 21 supports said movable structure 20 via interposed raising means 40.

[0014] Said raising means 40 are substantially identical to those used in fork lift trucks. Said means 40 comprise a pair of vertical rails 41 fixed to the movable base 21 at their lower ends and fixed together by a horizontal cross-member 41a. A vertical rectangular frame 42 is positioned between the two rails 41 and is vertically slidable along these rails 41, to which it is slidingly constrained by idle wheels 42a. The two vertical sides 43 of the frame 42 define two vertical rails, between which there is positioned a carriage 44 slidable vertically along these rails, to which it is slidingly constrained by idle wheels 44a.

[0015] The means 40 also comprise a cylinder-piston unit 45 of vertical axis, having its cylinder fixed to the cross-member 41a, its rod extending upwards and fixed at its upper end to a cross-member 42b of the frame 42. A transmission chain 46 is provided having one end fixed to the fixed cross-member 41a and its other end fixed to the movable carriage 44. The chain 46 passes about an idle sprocket 47 pivoted to the upper cross-member 42c of the movable frame 42.

[0016] By virtue of the described mechanism, every movement of the rod of the cylinder-piston unit 45 produces a corresponding movement of the carriage 44 but of double the length. Whereas the vertical rails 41 are fixed to the frame 21, the movable structure 20 is fixed to said carriage 44, and is hence raised in a vertical direction by the action of the cylinder-piston unit 45.

[0017] The movable structure 20 carries the entire movable seat 10, which in addition to the seating portion 11 comprises a crank mechanism 30 to be driven by the

muscular force of the child.

[0018] The crank mechanism 30 comprises a (double) crank 31 with pedals 32, which is positioned in the front part of the seat 10 in front of the seating portion 11 and is operated by the legs of the child seated on the seating portion 11. The crank mechanism also comprises a pulley wheel 38 (or a chain sprocket) applied to the shaft of the crank 31, to rotate via a belt 33 (or a chain) a second pulley wheel 34 (or a sprocket) keyed onto a second shaft 35 carrying a flywheel (not shown in the figures) on which there preferably acts a friction brake.

[0019] The described crank mechanism 30 is arranged to be driven by the muscular force of the child positioned on the movable seat, who rotates the pulley wheel 34 (or other rotary body).

[0020] The seat 10 can advantageously comprise a housing (not shown in the figures) enclosing the seating portion 11, the movable base 21 and the entire crank mechanism, and having a form which imitates a vehicle (or an animal, etc.) to increase the child enjoyment and amusement. For example, in the embodiment shown in the figures, the seat is suitable for enclosure within a housing imitating a helicopter or a similar flying vehicle. For this purpose, there are provided a simulated control device imitating an aircraft control stick positioned in front of the seating portion 11, and a rotating disc 14 and rotating propeller 13, these being positioned above the seating portion 11, to imitate the rotary members of a helicopter or the like. Advantageously, the propeller 13 and the disc 14 are rotated by a mechanical transmission operated by operating the crank mechanism 30. In this respect, a pair of bevel gears are provided, of which one, 36, is keyed onto the shaft 35 and engages the other gear 37, which is keyed onto a transmission shaft 39 (see Figure 4) housed within a vertical column 18 which is rigidly fixed to the seating portion 11 and supports the disc 14, the propeller 13 and other transmission shafts and bevel gears (of known type and not further described).

[0021] With the cylinder-piston unit 45 there is associated an operating circuit 50 (shown schematically in Figure 5) comprising a pump 51 driven by a relative motor 52 and having its delivery feeding the active chamber 45' of the cylinder-piston unit 45 via a line 53. This chamber is the lower chamber of the cylinder-piston unit 45, its expansion causing the rod of the unit to advance upwards.

[0022] In the line 53 there is provided a solenoid valve 54 arranged to deviate that oil flow directed towards the lower chamber 45' to the sump 55 via a discharge line 54'. In the line 53 there is also a second valve 56 which enables the oil to pass without throttling when the flow is directed towards the lower chamber 45'. This valve throttles the oil flow during its return from the lower chamber 45'.

[0023] According to the invention, the machine comprises a system for controlling the machine movements which inter alia enables one or more characteristics of

the seat movement to be varied, in a manner correlated with the speed with which the crank mechanism 30 is operated by the child seated on the seat 10.

[0024] This control system comprises firstly a controlling microprocessor 61 arranged to control substantially the entire machine operation. It also comprises means connected to the microprocessor 61 to measure the rotational speed of the wheel 34 (or of another rotary body operated by the crank mechanism 30). Specifically, the wheel 34 comprises holes 34' distributed angularly about the axis of rotation of the shaft 35, a sensor device (encoder) being provided to sense the presence of the holes 34' and feed a consequent signal to the microprocessor 61.

[0025] The device 62 could instead be applied to another rotary part provided it is rotated by the crank 31.

[0026] In particular, the control system is arranged to act on the operating circuit 50 for the raising means 40, on the basis of the rotational speed of said wheel 34, to vary characteristics of the raising movement. In a preferred but not exclusive application, the control system is programmed to act on the operating circuit 50 in such a manner as to raise the movable seat 10 if the rotational speed of the wheel exceeds a predetermined value, and to lower the movable seat if said speed is less than a predetermined value, or vice versa.

[0027] In detail, when during operation the child seated on the seat 10 operates the crank 31 with his feet at a speed exceeding the predetermined speed, the microprocessor 61 calculates this speed on the basis of the signals received from the encoder 62, to act on the valve 54 so that this closes the line 54' and opens the line 53. The pressurized oil leaving the pump 51 is consequently fed to the chamber of the cylinder-piston unit to raise the seat 10 by the described raising means 40. The circuit 50 also comprises an adjustable flow limiting valve 57 which limits the flow rate to the chamber 45'. By adjusting this valve it is hence possible to regulate the speed with which the seat 10 is raised. When the seat 10 has reached its maximum height (corresponding to the maximum emergence of the rod of the cylinder-piston unit 45), it halts in this position and the oil leaving the pump 52 is fed directly to the sump by the same valve 57.

[0028] If instead the crank 31 is operated at a speed lower than the predetermined speed, the microprocessor 61 acts on the valve 54 such that this closes the line 53 and opens the discharge line 54'. Consequently the oil leaving the pump 51 is fed to the sump 55 while the seat 10 descends downwards because of its weight. The fluid present in the chamber 45', being subjected to the pressure caused by the weight of the seat 10 acting on the rod of the cylinder-piston unit 45, is expelled from the chamber 45' (and fed to the sump via the line 54'). This fluid outflow causes the rod of the cylinder-piston unit 45 to descend (together with the seat 10), and is controlled by the throttling produced by the valve 56, the adjustment of which determines the speed with which

the seat 10 is lowered.

[0029] In the embodiment shown in the figures, besides rising and descending in a vertical or inclined direction, the movable seat 10 can also be made to rotate about the axis A, together with the movable base, by the action of the geared motor 23. In this case, using an inverter means 63, the microprocessor 61 is also able to vary the rotational speed of the geared motor 23, to consequently vary the speed with which the seat 10 is rotated about the axis A, this being dependent on the speed with which the crank 31 is operated.

[0030] In addition the control system can also be made to rotate the seat for a number of revolutions in one direction then a number of revolutions in the opposite direction.

[0031] Typically, but not exclusively, the machine also comprises a coin box 64 connected to the microprocessor 61, and into which the user inserts a coin (or a suitable token) to initiate the ride, and possibly loudspeaker means 65 to increase the enjoyment of the user.

[0032] The microprocessor 61, the sensor device 62, the inverter means 63, the geared motor 23 and the entire operating circuit 50 for the cylinder-piston unit 45 are all rotated by the movable base 21. Hence electrical power is fed to the motor 52, to the motor 23 via the inverter 63, and to the microprocessor via a sliding contact unit 27 comprising a series of blades 28 which move with the movable base 21 and slide along fixed circular tracks 29 (see Figure 5).

[0033] A power cable 71, connected to the electricity mains, is connected to the fixed tracks 29. A switch 72 operated by the coin box 64 is connected into the cable 71 to close the contact only against payment of a coin. From the contact unit 27 a cable 73 powers the microprocessor 61, another cable 74 powers the inverter 63 and a further cable 75 powers the motor 52.

[0034] In operation, the user firstly energizes the machine by inserting a coin (or token) into the coin box 64. After the machine has been energized in this manner, the motor 23 rotates the movable base 21 a few turns in one direction and a few turns in the other, and with it the seat 10. If the child seated on the seat 10 operates the crank 31 with a speed less than a predetermined value, the microprocessor 61, which measures this speed on the basis of the signals which it receives from the sensor 62, maintains the rotational speed of the movable base 21 low. The microprocessor 61 also acts on the valve 54 to close the line 53 and open the discharge line 54'. This causes the seat 10 to remain in its lowest position, or to descend into this position.

[0035] If instead the rotational speed of the crank 31 exceeds the predetermined value, the microprocessor 61 varies the rotational speed of the base 21 by acting on the motor 23 via the inverter 63. The microprocessor 61 also acts on the valve 54 to cause the pressurized oil from the pump 51 to feed the chamber 45', consequently causing the seat 10 to rise by the action of the described raising means 40.

[0036] Essentially, if the child pedals quickly, he increases the rotational speed about the axis A of the seat 10 on which he is seated and causes the seat 10 to rise. In contrast, if he pedals slowly or not at all, the seat 10 returns to its lowest position and the rotational speed decreases.

[0037] Numerous modifications can be made to the invention particularly with regard to those movement characteristics of the movable seat which change in relation to the speed with which the crank mechanism is operated by the child. For example, instead of the movable seat being made to move in the vertical direction (as heretofore described) it can be made to move in a different direction eg. forwards and rearwards, including horizontally. Alternatively, instead of being rotated about a vertical axis A, the seat can be rotated about an inclined or horizontal axis, and it can also be made to oscillate in one direction and the other through angles of less than 360°.

[0038] Numerous modifications of a practical and applicational nature can be made to the invention, but without leaving the scope of the inventive idea as hereinafter claimed.

Claims

1. An amusement machine comprising:

at least one movable seat (10) carried by a movable structure (20) arranged to movingly transport a child, motor means (23,52) for moving said movable seat (10), said motor means being energised during the operation to move the movable seat (10), a crank mechanism (30) applied to the movable seat (10), having a crank (31) to be operated by the muscular force of the child seated on the seat (10) with a pedalling action, a control system for the machine movements acting on motors means (23, 52) which is able to vary characteristics of the seat movement produced by motor means (23, 52) during operation if the rotational speed of said pedalled crank (31) exceeds or is less than a predetermined value.

2. An amusement machine as claimed in claim 1, characterised in that said crank mechanism (30) comprises a wheel (14), or another rotary body, which is rotated by the action of the child on the crank mechanism (30), the control system comprising means (62) for measuring the rotation of said wheel (34) or rotary body and a controlling microprocessor (61) connected to the measurement means (62) to vary characteristics of the movement of the seat (10) in a manner correlated with the

speed with which the crank mechanism (30) is rotated.

3. An amusement machine as claimed in claim 2, **characterised in that** the movable seat (10) comprises a pedalled crank (31) which operates said wheel (34), and is operated by the legs of the child carried by the seat. 5
4. An amusement machine as claimed in claim 2, **characterised in that** said movable seat (10) is raised by raising means (40), the control system being arranged to act on the operating circuit (50) of the raising means (40) on the basis of the rotational speed of said wheel (34), to vary characteristics of the raising movement. 10 15
5. An amusement machine as claimed in claim 4, **characterised in that** the control system is arranged to act on the operating circuit (50) of the raising means (40) in such a manner as to raise or to lower the movable seat (10). 20
6. An amusement machine as claimed in claim 5, **characterised in that** the raising means (40) comprise a hydraulic cylinder-piston unit (45) having an active chamber (45'), said operating circuit (50) of the cylinder-piston unit (45) comprising a pump (51) and a hydraulic circuit which feeds the lower chamber (45') of the cylinder-piston unit and has a solenoid valve (54) operable by the control system to deviate to the sump that oil flow directed towards the active chamber (45'), and a valve (56) which enables the oil to pass to the lower chamber (45') of the cylinder-piston unit without throttling, but throttles the oil flow returning from the active chamber (45'). 25 30 35
7. An amusement machine as claimed in claim 4, **characterised in that** said movable seat (10) is carried by a base (21) rotating about an axis A and connected to drive means (23) which rotate the base (21) about the axis A, the control system being arranged to vary the rotational speed of the movable seat (10) about said axis A in a manner correlated with the speed with which the crank mechanism (30) is operated by the child seated on the seat. 40 45

Patentansprüche 50

1. Vergnügungsgerät, welches folgendes aufweist:

Wenigstens einen beweglichen Sitz (10), welcher von einer beweglichen Struktur (20) getragen ist, welche dafür vorgesehen ist, ein Kind auf bewegliche Art und Weise zu transportieren, 55

Motoreinrichtungen (23,52) zum Bewegen des beweglichen Sitzes (10), wobei die Motoreinrichtungen während des Betriebs mit Energie versorgt werden, um den beweglichen Sitz (10) zu bewegen,

einen Kurbelmechanismus (30), welcher an dem beweglichen Sitz (10) angebracht ist und eine Kurbel (31) aufweist, welche durch die Muskelkraft des auf dem Sitz (10) sitzenden Kindes mittels einer Pedalbewegung zu betreiben ist,

ein Steuersystem für die Bewegungen der Maschine, welche auf die Motoreinrichtungen (23,52) wirkt und welche in der Lage ist, Eigenschaften der Bewegung des Sitzes, welche von den Motoreinrichtungen (23,52) während des Betriebs erzeugt werden, zu variieren, falls die Rotationsgeschwindigkeit der Pedal betriebenen Kurbel (31) einen vorbestimmten Wert überschreitet oder geringer als dieser ist.

2. Vergnügungsgerät nach Anspruch 1, **dadurch gekennzeichnet, dass** der Kurbelmechanismus (30) ein Rad (14) oder einen anderen Rotationskörper aufweist, welcher durch die Betätigung des Kurbelmechanismus (30) durch das Kind rotiert wird, wobei das Steuersystem eine Einrichtung (62) zum Messen der Rotation des Rades (34) oder des Rotationskörpers sowie einen Steuerungs-Mikroprozessor (61) aufweist, welcher mit der Messeinrichtung (62) verbunden ist, um Eigenschaften der Bewegung des Sitzes (10) auf eine Art und Weise zu variieren, welche in Übereinstimmung mit der Geschwindigkeit ist, mit welcher der Kurbelmechanismus (30) rotiert wird.
3. Vergnügungsgerät nach Anspruch 2, **dadurch gekennzeichnet, dass** der bewegliche Sitz (10) eine über ein Pedal zu betätigende Kurbel (31) aufweist, welche das Rad (34) betätigt und durch die Beine des Kindes, welches von dem Sitz getragen wird, betrieben wird.
4. Vergnügungsgerät nach Anspruch 2, **dadurch gekennzeichnet, dass** der bewegliche Sitz (10) mittels einer Hebeeinrichtung (40) angehoben wird, wobei das Steuerungssystem dafür vorgesehen ist, auf den Betriebskreislauf (50) der Hebeeinrichtung (40) auf der Basis der Rotationsgeschwindigkeit des Rades (34) einzuwirken, um Eigenschaften der Anhebebewegung zu variieren.
5. Vergnügungsgerät nach Anspruch 4, **dadurch gekennzeichnet, dass** das Steuerungssystem dafür vorgesehen ist, auf den Betriebskreislauf (50) der Hebeeinrichtung (40) auf eine solche Art und Weise einzuwirken, um den beweglichen Sitz (10) anzuheben oder abzusenken.

6. Vergnügungsgerät nach Anspruch 5, **dadurch gekennzeichnet, dass** die Hebeeinrichtung (40) eine hydraulische Zylinder-Kolben-Einheit (45) aufweist, welcher eine Arbeitskammer (45') aufweist, wobei der Betriebskreislauf (50) der Zylinder-Kolben-Einheit (45) eine Pumpe (51) und einen hydraulischen Kreislauf aufweist, welcher die untere Kammer (45') der Zylinder-Kolben-Einheit versorgt und ein Magnetventil (54), welches durch das Steuerungssystem betätigbar ist, um denjenigen Ölfluss zu dem Pumpensumpf abzuzweigen, der zu der Arbeitskammer (45') gerichtet ist, sowie ein Ventil (56) aufweist, welches es dem Öl ermöglicht, ohne Drosselung zu der unteren Kammer (45') der Zylinder-Kolben-Einheit zu gelangen, jedoch den von der Arbeitskammer (45) zurückkehrenden Ölfluss drosselt.
7. Vergnügungsgerät nach Anspruch 4, **dadurch gekennzeichnet, dass** der bewegliche Sitz (10) von einem Grundkörper (21) gehalten ist, welcher um eine Achse A rotiert und mit der Antriebseinrichtung (23) verbunden ist, welche den Grundkörper (21) um die Achse A rotiert, wobei das Steuerungssystem dafür vorgesehen ist, die Rotationsgeschwindigkeit des beweglichen Sitzes (10) um die Achse A auf eine Art und Weise zu variieren, welche in Übereinstimmung mit der Geschwindigkeit ist, mit welcher der Kurbelmechanismus (30) von dem Kind, welches auf dem Sitz sitzt, betrieben wird.

Revendications

1. Une machine d'amusement comprenant :

au moins un siège mobile (10) soutenu par une structure mobile (20) aménagée de façon à transporter un enfant d'une manière mobile, des moyens à moteur (23,52) pour faire bouger ledit siège mobile (10), lesdits moyens à moteur étant alimentés en énergie tout au long de l'opération de faire bouger le siège mobile (10), un mécanisme à manivelle (30) appliqué au siège mobile (10), ayant une manivelle (31) à actionner par la force musculaire de l'enfant assis dans le siège (10) moyennant une action de coups de pédale, un système de commande pour les mouvements de la machine agissant sur les moyens à moteur (23,52) qui est en état de varier les caractéristiques du mouvement du siège produit par les moyens à moteur (23,52) pendant le fonctionnement si la vitesse d'orientation de ladite manivelle actionnée à coups de pédale (31) excède ou est inférieure à une valeur prédéterminée.

2. Une machine d'amusement selon la revendication 1, **caractérisée en ce que** ledit mécanisme à manivelle (30) comprend une roue (14) ou un différent corps tournant, que fait tourner l'action de l'enfant sur le mécanisme à manivelle (30), le système de commande comprenant des moyens (62) pour mesurer la rotation de ladite roue (34) ou corps tournant, ainsi qu'un microprocesseur de contrôle (61) branché aux moyens de mesurage (62) pour varier les caractéristiques de mouvement du siège (10) d'une manière corrélée à la vitesse à laquelle on fait tourner le mécanisme à manivelle (30).
3. Une machine d'amusement selon la revendication 2, **caractérisée en ce que** le siège mobile (10) comprend une manivelle actionnée à coups de pédale (31) qui met en marche ladite roue (34), et qui est entraînée par les jambes de l'enfant transporté par le siège.
4. Une machine d'amusement selon la revendication 2, **caractérisée en ce que** ledit siège mobile (10) est soulevé par des moyens de soulèvement (40), le système de commande étant préparé de façon à agir sur le circuit de service (50) des moyens de soulèvement (40) à partir de la vitesse d'orientation de ladite roue (34), pour varier les caractéristiques du mouvement de soulèvement.
5. Une machine d'amusement selon la revendication 4, **caractérisée en ce que** le système de commande est préparé de façon à agir sur le circuit de service (50) des moyens de soulèvement (40) en vue de soulever ou de baisser le siège mobile (10).
6. Une machine d'amusement selon la revendication 5, **caractérisée en ce que** les moyens de soulèvement (40) comprennent une unité hydraulique cylindre-piston (45) ayant une chambre active (45'), ledit circuit de service (50) de l'unité cylindre-piston (45) comprenant une pompe (51) et un circuit hydraulique qui alimente la chambre inférieure (45') de l'unité cylindre-piston et présente une valve électromagnétique (54) qui peut être mise en marche par le système de commande pour détourner vers le regard le débit d'huile se dirigeant dans la chambre active (45'), et une soupape (56) qui permet à l'huile de passer dans la chambre inférieure (45') de l'unité cylindre-piston sans étrangler, mais qui étrangle le débit d'huile retournant de la chambre active (45').
7. Une machine d'amusement selon la revendication 4, **caractérisée en ce que** ledit siège mobile (10) est soutenu par une base (21) tournant autour d'un axe A et branchée à des moyens d'entraînement (23) qui font tourner la base (21) autour de l'axe A, le système de commande étant préparé pour varier

la vitesse d'orientation du siège mobile (10) autour dudit axe A d'une manière corrélée à la vitesse à laquelle le mécanisme à manivelle (30) est déclenché par l'enfant assis dans le siège.

5

10

15

20

25

30

35

40

45

50

55

7

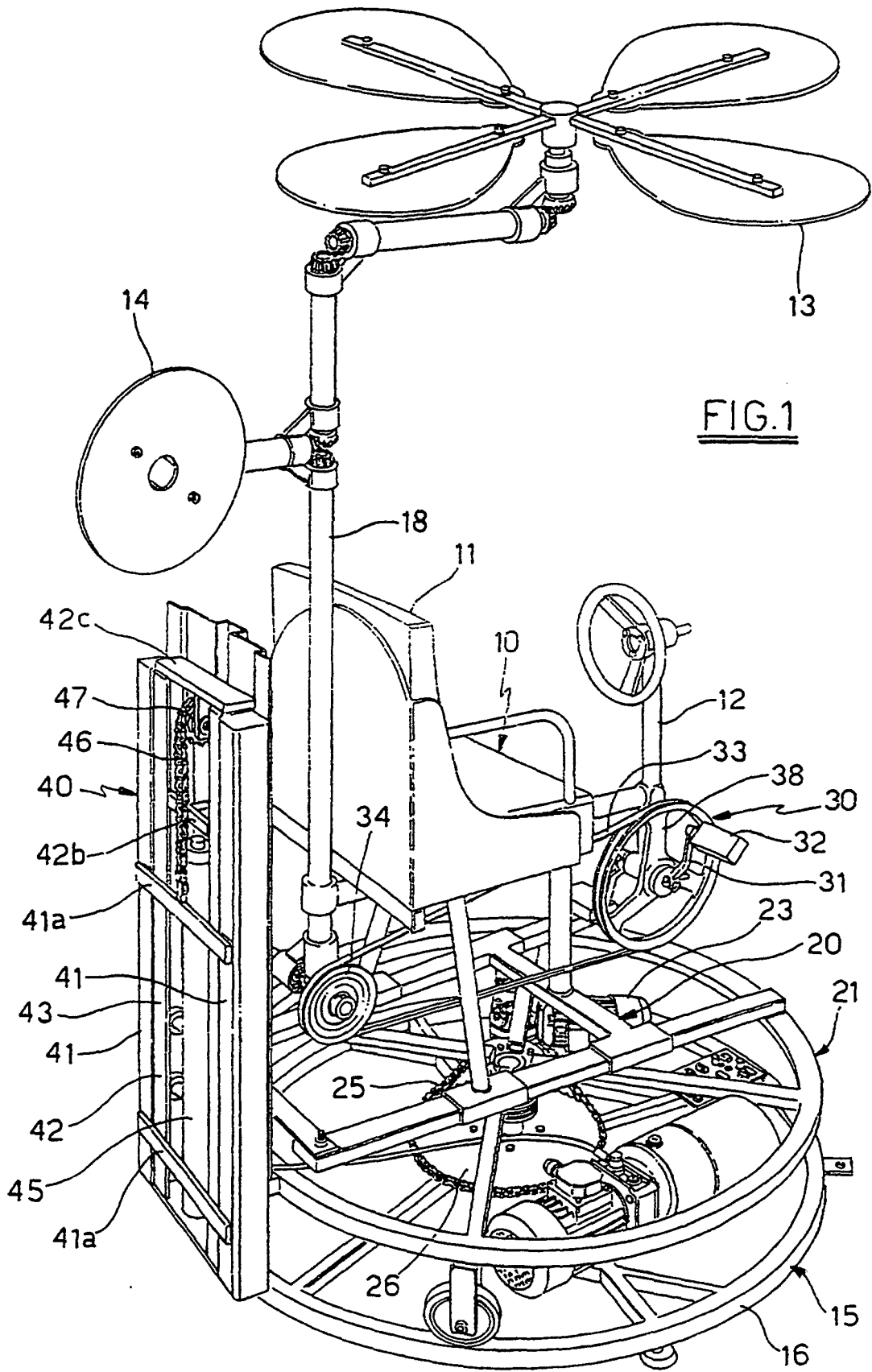

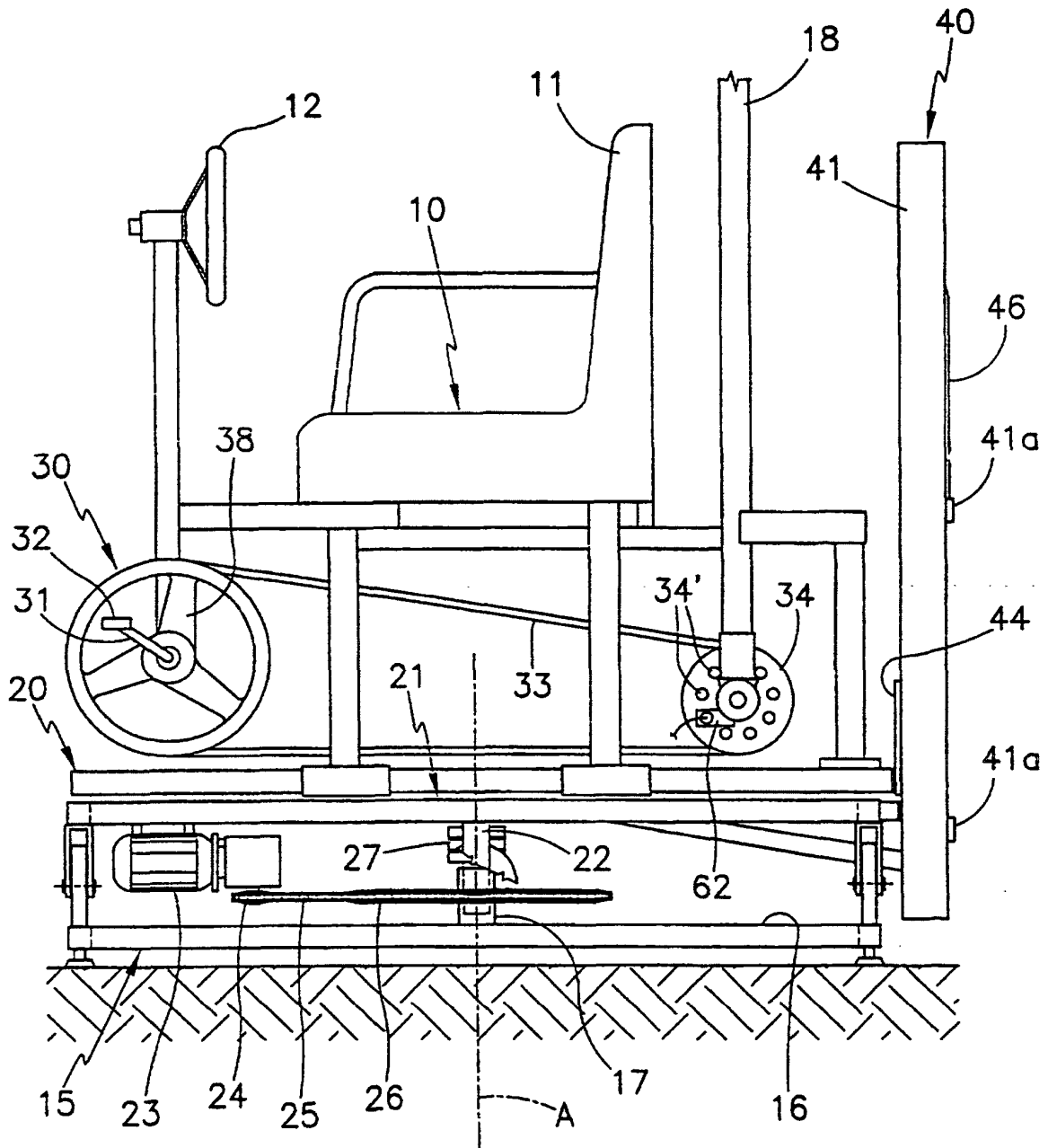

FIG.2

