



Europäisches Patentamt
European Patent Office
Office européen des brevets



(11) **EP 1 041 285 B1**

(12) **EUROPEAN PATENT SPECIFICATION**

(45) Date of publication and mention
of the grant of the patent:
09.03.2005 Bulletin 2005/10

(51) Int Cl.7: **F04B 39/12**, F04B 39/00,
F04B 27/10

(21) Application number: **00302566.5**

(22) Date of filing: **28.03.2000**

(54) **Reciprocating type compressor comprising a suction chamber and partition walls in a cylinder head**

Verdrängerverdichter mit einer Saugkammer und Trennwände in einem Zylinderkopf

Compresseur alternatif comprenant une chambre d'aspiration et des parois de séparation dans une culasse

(84) Designated Contracting States:
DE FR

(30) Priority: **01.04.1999 JP 9493699**

(43) Date of publication of application:
04.10.2000 Bulletin 2000/40

(73) Proprietor: **SANDEN CORPORATION**
Isesaki-shi Gunma 372 (JP)

(72) Inventors:
• **Hashimoto, Kenji**
Isesaki-shi, Gunma 372 (JP)

• **Ichikawa, Yoshinobu**
Isesaki-shi, Gunma 372 (JP)

(74) Representative: **Haley, Stephen**
Gill Jennings & Every,
Broadgate House,
7 Eldon Street
London EC2M 7LH (GB)

(56) References cited:
JP-A- 7 035 039 **US-A- 4 070 136**
US-A- 4 813 852 **US-A- 4 880 361**
US-A- 4 936 754

EP 1 041 285 B1

Note: Within nine months from the publication of the mention of the grant of the European patent, any person may give notice to the European Patent Office of opposition to the European patent granted. Notice of opposition shall be filed in a written reasoned statement. It shall not be deemed to have been filed until the opposition fee has been paid. (Art. 99(1) European Patent Convention).

Description

[0001] The present invention relates to the improvement of the refrigerant gas suction passage of a reciprocating type compressor.

[0002] Conventionally, a reciprocating type compressor is arranged such that a cylinder head has a series of partition walls for separating the internal space thereof to a suction chamber and a discharge chamber. The suction chamber is arranged as a common suction space without any partition and the refrigerant gas introduced from the introduction hole of the cylinder head is sequentially sucked from the suction ports of a valve plate coupled with a cylinder block according to the suction stroke of pistons (hereinafter, referred to as conventional art 1).

[0003] In the conventional art 1, the refrigerant gases are sucked from the refrigerant introduction holes of the cylinder head to respective bores and the lengths of passages of the refrigerant gases are different depending upon respective bores. Further, since the refrigerant gases are sucked in the common suction space, pulsation is caused in the pressure of the sucked gas by the dynamic interference among the gases sucked into the respective bores. The pressure pulsation is transmitted to an evaporator in the inside of a car through piping. Thus, unpleasant noise due to resonance becomes a problem.

[0004] Japanese Unexamined Patent Publication No. 7-35039 (hereinafter, referred to as conventional art 2) discloses a technology for preventing the occurrence of noise. US-A-4880361 discloses a multi-piston swash plate compressor with an internal sealing arrangement. US-A-5556260, US-A-4690619 and DE-A-3605936 disclose other arrangements of compressors.

[0005] The reciprocating type compressor disclosed in the conventional art 2 includes a cylinder block having a plurality of bores formed in parallel with a central axis, a drive shaft having an end fitted in and supported by the shaft hole of the cylinder block and the other end supported by a front housing, pistons coupled with a swash plate, which is moved together with the drive shaft, and moving linearly in the bores, a housing jointed to the outside end of the cylinder block through a valve plate and a suction unit formed on the housing and communicating with the bores through suction ports formed passing through the valve plate. The suction unit is compressed of a refrigerant introduction hole and pipe-shaped branch passages radially branched from the refrigerant introduction hole in six directions and independently communicating with the respective suction ports, respectively. The cross sections of a series of all the refrigerant passages including the suction unit and the suction ports are formed to have the same shape and the same size.

[0006] In the conventional art 2, however, each of the branch passages communicating with the respective cylinders is formed in the pipe-shape having a relatively

small diameter and has a long distance. Thus, a problem arises in that pressure losses in the branch passages are increased following the decrease in refrigerating capability. Further, since one end of respective branch ports are formed to join at the positions just below the refrigerant introduction port, the amount of refrigerant sucked into the cylinders is liable to be affected by the change of the flow rate of the refrigerant. As a result, the reciprocating type compressor is also disadvantageous in that the components of a drive mechanism are undesirably vibrated to result in generation of unpleasant noise.

[0007] It is an object of the present invention to provide a reciprocating type compressor including a cylinder head capable of suppressing the pulsation of suction pressure and preventing the reduction of refrigerating capability thereby at a less expensive cost.

[0008] It is another object of the present invention to provide a reciprocating type compressor including a cylinder head which makes it difficult for the amount of refrigerant sucked into cylinders to be affected by the change of the flow rate of refrigerant and which can prevent the unpleasant noise generated from the components constituting a drive mechanism thereby at a less expensive cost.

[0009] According to the present invention, there is provided a reciprocating type compressor comprising:

a cylinder block with a plurality of cylinder bores formed therein;
 a plurality of pistons received in said cylinder bores, respectively;
 a cylinder head connected to said cylinder block and having a refrigerant introduction hole;
 a suction chamber provided in said cylinder head and connecting said refrigerant introduction hole to said cylinder bores, said compressor compressing a fluid introduced into said cylinder bores by the reciprocating motion of said pistons in said cylinder bores, said cylinder head comprising partition walls extending substantially radially inwardly from a side wall of the cylinder head toward the refrigerant introduction hole dividing said suction chamber into fluid paths for introducing the fluid into respective cylinder bores,

characterised in that:

a void in the suction chamber is formed by the extended end portions of the partition walls (107) and is formed adjacent the refrigerant hole in a tapered shape so that the cross-sectional area defined by each of the extended end portions of the partition walls thereof is gradually increased inwardly, and a plurality of projecting folds are formed on the extended end portions of the partition wall surface thereof.

[0010] In the drawings:

Fig. 1 is a sectional view showing a reciprocating type compressor according to the conventional art 2;

Fig. 2 is a sectional view taken along the line 11-11 of the reciprocating type compressor of Fig. 1;

Fig. 3 is a sectional view showing a reciprocating type compressor

Fig. 4 is a partial sectional view showing the cylinder block of the reciprocating type compressor of Fig. 3; Fig. 5 is a view of a first cylinder head unit of Fig. 4 looked from the section taken along the line V - V of Fig. 4;

Fig. 6 is a view of a second cylinder head unit of Fig. 4 looked from the section taken along the line VI - VI of Fig. 4;

Fig. 7 is a graph showing a pressure pulsation suppressing effect of the reciprocating type compressor

Fig. 8A is a sectional view showing a portion of the cylinder head of a reciprocating type compressor according to the present invention;

Fig. 8B is a view of the cylinder head of Fig. 8A looked from below it; and

Fig. 9 is a view showing a portion of the cylinder head of a reciprocating type compressor.

[0011] Before the description of the present invention, a reciprocating type compressor according to a conventional art will be described for the easy understanding of the present invention.

[0012] Referring to Fig. 1, the reciprocating type compressor 11 shown in the conventional art 2 includes a cylinder block 15 formed into one body with a main housing 12 and having a plurality of bores 13 disposed in parallel with a central axis, a drive shaft 21 having one end fitted into and supported by a shaft hole 17 of the cylinder block 15 and the other end supported by a front housing 19, pistons 25 coupled with a swash plate 23, which is moved together with the drive shaft 21, and moving linearly in the bores 13, a housing 29 jointed to the outside end of the cylinder block 15 through a valve plate 27, and a suction unit 33 communicating with the bores 13 through suction ports 31 formed to pass through the valve plate 27 formed on the housing 29.

[0013] The reciprocating type compressor according to the conventional art 2 employs the rotary swash plate 23 and converts a rotating motion thereof into the reciprocating motions of the pistons 25 through shoes 41.

[0014] Referring to Fig. 2 in addition to Fig. 1, the suction unit 33 is composed of a refrigerant introduction port 35 and pipe-shaped branch passages 37 which are radially branched from the refrigerant introduction port 35 in six directions and independently communicate with respective suction ports 31. The suction unit 33 and a series of the refrigerant passages 37 including the suction ports 31 have the same shape and the same size. Note that numeral 39 denotes a refrigerant discharge

port.

[0015] The present invention will be described with reference to the drawings.

[0016] Referring to Fig. 3, a reciprocating type compressor 43 of a first embodiment of the present invention includes a cylinder block 49 formed integrally with a casing or housing 47 including a plurality cylinder bores 45, and a front housing 51 disposed at an end of the housing 47. Further, the reciprocating type compressor 43 includes a rotatable shaft 55 which is inserted up to the insertion hole 53 of the cylinder block 49 in the casing 47 through the front housing 51. The rotatable shaft 55 is rotatably supported by the front housing 51 and the cylinder block 49 through bearings 57 and 59, respectively. A rotor 61 is disposed to the rotatable shaft 55 at a position near to the front housing 51 and fixed to the rotation shaft 55 by a bolt 63. An end of the rotor 61 is supported by the inner wall of the front housing 51 through a thrust bearing 65 and the other thereof is coupled with an end of a slant plate 67 disposed around the rotatable shaft 55 through a hinged joint mechanism 69. A wobble plate 71 is disposed around the cylindrical portion of the slant plate 67 at the central portion thereof so as to swing in accordance with a rotation of the slant plate 67 through a thrust bearing 73. A groove is formed at a portion 75a of the periphery of the wobble plate 71 and engaged with a rail plate 75b disposed in the casing 47 so that it can be moved along an axial direction with preventing from rotating. The wobble plate 71 and the rail plate 75b constitute a rotation preventing mechanism 77. The rotation preventing mechanism 77 is arranged such that it can move the wobble plate 71 in the direction along the rotatable shaft 55 but it prevents the wobble plate 71 from rotating around the rotatable shaft 55.

[0017] Pistons 81 are disposed in the cylinder bores 45 of the cylinder block 49 and connected to the peripheral portion of the wobble plate 71 on the other end thereof through piston rods 83.

[0018] A cylinder head 87 is disposed to the other end of the cylinder block 49 of the casing 47 through a valve plate device 85.

[0019] The valve plate device 85 includes a valve plate main body 85a, which has a not shown suction valve and a discharge valve 89, and a retainer 91. The suction valve and the discharge valve are formed on both of surfaces of the valve plate and stacked under seal members (not shown), respectively. The retainer 91 is disposed so as to cover the discharge valve 89. These components are assembled by a bolt 93 so that they are integrated with the valve plate main body 85a.

[0020] Referring to Fig. 4, the cylinder head 87 includes a first cylinder head unit 95 disposed to the outside of the compressor and a second cylinder head unit 97 interposed between the first cylinder head unit 95 and the valve plate device 85.

[0021] The first cylinder head unit 95 includes a bottom wall 101 and a cylindrical side wall 103 standing

vertically from the periphery of the bottom wall 101. A refrigerant introduction hole 105 is formed at the center of the bottom wall 101.

[0022] Referring to Fig. 5, a plurality of, seven pieces in the embodiment, partition walls 107 substantially extend radially inwardly from the positions of the cylindrical side wall 103 in a peripheral direction at approximately similar intervals and the extended end portions of the partition walls 107 are located radially outwardly of the refrigerant introduction hole 105. With this structure, a plurality of, seven pieces in the embodiment, voids 109 which will be hereinafter referred to as first suction chambers 109, are partitioned by adjacent partition walls 107 and portions of the side wall 103 in correspondence to the cylinder bores 45. In addition, a void 111 is formed by being surrounded by the extended end portions of the partition walls 107. Note that, as can be seen from Fig. 5, the inner ends in the radial direction of the first suction chambers 109 are open to the void 111, respectively. The extended end portion of one of the partition walls 107 has an elliptic cross section and a blind screw hole 115 is drilled thereto in an axial direction. The extended end portion of another one of the partition walls 107 also has a circular cross section and a through-hole 113 for a discharge port 127 is drilled therethrough in the axial direction. Further, boss portions 116 are formed at the portions of the side wall 103 corresponding to the base portions of the respective the partition walls 107 and screw inserting holes 119 are drilled to the boss portions 116 in the axial direction. Note that the side wall 103, the partition walls 107 and the boss portions 116 are designed to have the same height, respectively.

[0023] Referring to Fig. 6 in addition to Fig. 4, the second cylinder head unit 97 includes a bottom wall 121 and a cylindrical thick side wall 117 standing vertically from the peripheral edge of the bottom wall 121. The side wall 117 has a plurality of through-holes 123 drilled thereto in correspondence to the voids 109 of the first cylinder head unit 95. The lateral cross section of each through-hole 123 is formed in an elliptic shape having a large area. Hereinafter, the through-holes 123 are referred to as second suction chambers 123. When the first and second cylinder head units 95 and 97 are assembled as shown in Fig. 4, the first suction chambers 109 of the first cylinder head unit 95 communicate with the second suction chambers 123 of the second cylinder head unit 97 which correspond thereto. Further, the bottom wall 121 has through-holes 125 drilled thereto at the positions thereof corresponding to the above through-holes 113 and a discharge hole 127 is formed by the through-holes 113 and 125. Note that the inside surface 129 of the side wall 117 is waved radially.

[0024] As reviewing in Fig. 4, a discharge chamber 131 is partitioned by the side wall 117, the bottom wall 121 and the valve plate device 85. Referring to Fig. 6 again, a plurality of screw inserting holes 133 are drilled to the side wall 117 in correspondence to the screw in-

serting holes 119 of the first cylinder head unit 95. As shown in Fig. 3, shaft portions of bolts 135 pass through a plurality of screw inserting holes 133 and the screw inserting holes 85b drilled to the valve plate device 85 in correspondence to the screw inserting holes 119 and are screwed into screw holes 49a drilled to the cylinder block 49, whereby the first and second cylinder head units 95 and 97, the valve plate device 85 and the cylinder block 49 are fixed to each other. Note that while the side wall 117 is formed integrally with the bottom wall 121 in the present invention, the side wall 117 may be formed separately from the bottom wall 121 and thereafter the two members may be fixed to each other.

[0025] When the rotatable shaft 55 is rotated by a not shown drive source in the reciprocating type compressor according to the first embodiment arranged as described above, the rotor 61 is rotated thereby so that the slant plate 67 coupled with the rotor 61 is rotated. The rotation of the slant plate 67 is converted into the axial reciprocating motions in the axial direction of the pistons 81 in the cylinder bores 45.

[0026] With the above arrangement, refrigerant gases flow from an external refrigerant circuit into the void 111 through refrigerant introduction hole 105 and further flows into first suction chambers 109. The refrigerant gases having flowed into the first suction chambers 109 further flow into the second suction chambers 123 and then sucked into the cylinder bores 45 through suction ports 139. Thereafter, the refrigerant gases having been compressed by the pistons 81 are discharged into a discharge chamber 131 from the cylinder bores 45 through a discharge port 141 and flow to the external refrigerant circuit through the discharge port 127.

[0027] As described above, the refrigerant passage from the refrigerant introduction hole 105 to the cylinder bores 45 is formed of the void 111, the first suction chambers 109 and the second suction chambers 123. Therefore, the refrigerant gases having flowed from the external refrigerant circuit into the void 111 through the refrigerant introduction hole 105 flow into the first suction chambers 109 which correspond to the respective cylinder bores 45 and further are substantially isolated from each other. With this arrangement, when the refrigerant gases are sucked into the respective cylinder bores 45, the mutual dynamic interference of the refrigerant gases is reduced and thus the pulsation of the suction pressure of the refrigerant gases can be suppressed. As a result, it is possible to lower the noise level in the inside of a car.

[0028] Further, according to the present invention, a large pressure loss is not caused in the refrigerant passage from refrigerant introduction hole 105 to the cylinder bores 45 because any of the void 111, first suction chambers 109 and second suction chambers 123 has a large volume.

[0029] Further, according to the present invention, since the refrigerant gases having flown from the external refrigerant circuit into the void through the refrigerant introduction hole 105 is received once by the first suction

chambers 109 which are isolated from each other, it is difficult for the amount of the refrigerant sucked by the cylinders to be affected by the change of the flow rate of the refrigerant supplied to the compressor, whereby the unpleasant noise generated from the parts such as a wobble plate 71 which constitute a driving mechanism can be prevented.

[0030] Fig. 7 is a graph showing that the pulsation of suction pressure is suppressed by the present invention described above. In the graph, the ordinate shows the magnitude of suction gas pulsation (unit: dBEU, wherein EU is the abbreviation of engineering unit) and the abscissa shows the flow rate (unit: kg/hour) of liquid refrigerant in the liquid line of a refrigerating circuit (portion from a condensation vessel to an expanding function element). Note that the magnitude of suction gas pulsation of the ordinate is measured in the frequency range of 440 - 500 Hz, and curves 139 and 141, in which 0 dBEU is defined as 1 g/cm² (0 dBEU = 1 g/cm²), show the characteristics of the above conventional art 1 and the present invention, respectively. As apparent from the curve 139 and the curve 141, it can be found that the value of suction pressure pulsation of the present invention is always lower than that of the conventional art 1 regardless of the compensation of the flow rate of the liquid refrigerant.

[0031] Referring to Figs. 8A and 8B, the cylinder head of a reciprocating type compressor according to the present invention is arranged similarly to the cylinder head shown in Fig. 3 to Fig. 6 except the structure of a void 111 is different.

[0032] That is, the void 111 is formed in a taper shape so that the diameter of the inner wall or partition wall 107 thereof is gradually increased inwardly as well as a plurality of projecting folds 107a are formed on the inner wall surface thereof. Each of the projecting folds 107a has a size and shape of such a degree as not to cause a pressure loss.

[0033] In the reciprocating type compressor according to the present invention arranged as described above, since the suction chamber of the cylinder head is formed in the taper shape, the pressure loss of suction gases is not clearly produced but the attenuation of pressure pulsation is more accelerated by the projecting folds 107a.

[0034] Referring to Fig. 9, a first cylinder head unit 95 is arranged such that a plurality of straightening plates 107b, each of which is composed of a plate member projecting in a direction perpendicular to the direction in which each partition wall 107 extends, are disposed to the partition walls 107 on both the sides in the lengthwise direction thereof. Each straightening plate 107b has a size and shape of such a degree as not to cause a pressure loss.

[0035] Pressure pulsation is more attenuated than that of the reciprocating type compressor of the first embodiment by the straightening plates 107b provided with the partition walls 107.

[0036] While the embodiments of the present invention have been described as to the reciprocating type compressor using the wobble plate, it is needless to say that the present invention is also applicable to a reciprocating type compressor which converts a rotating motion to the reciprocating motions of pistons by means of the rotary slant plate of conventional arts through shoes.

[0037] As described above, according to the present invention, when refrigerant gases are sucked into the cylinder bores, it is possible to lower the noise level in the inside of a car because the mutual dynamic interference among the suction refrigerant gases can be reduced as well as the pulsation of the suction pressure of the refrigerant gases can be also suppressed.

[0038] Further, since a large pressure loss is not produced in the refrigerant passage from the refrigerant introduction hole to the cylinder bores, it is possible to prevent the reduction of the refrigerating capability of the compressor.

[0039] Furthermore, it is difficult for the amount of the refrigerant sucked into the cylinder to be affected by the change of the flow rate of the refrigerant supplied to the compressor, whereby the unpleasant noise generated from the parts constituting the driving mechanism can be prevented.

Claims

1. A reciprocating type compressor (43) comprising:

a cylinder block (49) with a plurality of cylinder bores (45) formed therein;

a plurality of pistons (81) received in said cylinder bores, respectively;

a cylinder head (87) connected to said cylinder block and having a refrigerant introduction hole (105);

a suction chamber (109,111,123) provided in said cylinder head and connecting said refrigerant introduction hole to said cylinder bores, said compressor compressing a fluid introduced into said cylinder bores by the reciprocating motion of said pistons in said cylinder bores, said cylinder head comprising partition walls (107) extending substantially radially inwardly from a side wall of the cylinder head toward the refrigerant introduction hole dividing said suction chamber into fluid paths for introducing the fluid into respective cylinder bores,
characterised in that:

a void (111) in the suction chamber is formed by the extended end portions of the partition walls (107) and is formed adjacent the refrigerant hole (105) in a tapered shape so that the cross-sectional area defined by each of the extended end portions

of the partition walls thereof is gradually increased inwardly, and a plurality of projecting folds (107a) are formed on the extended end portions of the partition wall surface thereof.

2. A reciprocating type compressor (43) according to claim 1, wherein said partition walls (107) are extended from portions of a side wall (103) of the cylinder head towards said refrigerant introduction hole (105).
3. A reciprocating type compressor (43) according to claim 2, wherein said partition walls (107) are extended from the portions of the side wall (103), the portions being spaced at an equiangular interval from each other.
4. A reciprocating type compressor (43) according to claim 1, further comprising a rotation conversion mechanism for converting the rotating motion of a rotatable shaft (55) into the reciprocating motion of said pistons in the direction of said rotatable shaft, said rotation conversion mechanism being one selected from a rotating swash plate mechanism and a wobble plate mechanism.
5. A reciprocating type compressor (43) according to claim 1, wherein said cylinder head (49) is made of two divisional portions in an axial direction, one of said divisional portions being provided with a discharge chamber (131) and a through hole (127), another one being provided with voids (109) divided from each other by partition walls (107).

Patentansprüche

1. Ein Kolbenkompressor (43), der aufweist:

einen Zylinderblock (49) mit einer Mehrzahl darin ausgebildeten Zylinderbohrungen (45);
 eine Mehrzahl an Kolben (81), die jeweils in den Zylinderbohrungen aufgenommen sind;
 einen Zylinderkopf (87), der mit dem Zylinderblock verbunden ist und der ein Kältemittel-Einlaßloch (105) aufweist;
 eine Ansaugkammer (109, 111, 123), die in dem Zylinderkopf vorgesehen ist und die das Kältemittel-Einlaßloch mit den Zylinderbohrungen verbindet, wobei der Kompressor ein Fluid, das in die Zylinderbohrungen eingelassen wird, durch die hin- und hergehende Bewegung der Kolben in den Zylinderbohrungen komprimiert, wobei der Zylinderkopf Trennwände (107) aufweist, die sich von einer Seitenwand des Zylinderkopfs im wesentlichen radial nach innen in Richtung des Kältemittel-Einlaßloches erstrecken

und welche die Ansaugkammer in Fluidpfade zum Einlassen des Fluids in entsprechende Zylinderbohrungen unterteilen, **dadurch gekennzeichnet, daß:**

ein Hohlraum (111) in der Ansaugkammer durch die ausgedehnten Endabschnitte der Trennwände (107) gebildet wird und angrenzend an das Kältemittelloch (105) in einer sich verjüngenden Form derart ausgebildet ist, so daß die Querschnittsfläche, die durch jeden der ausgedehnten Endabschnitte der Trennwände davon definiert wird, graduell nach innen vergrößert wird, und eine Mehrzahl an vorstehenden Falten (107a) auf den ausgedehnten Endabschnitten der Trennwandoberfläche davon ausgebildet sind.

2. Ein Kolbenkompressor (43) gemäß Anspruch 1, bei dem sich die Trennwände (107) von Abschnitten einer Seitenwand (103) des Zylinderkopfs in Richtung zu dem Kältemittel-Einlaßloch (105) erstrecken.
3. Ein Kolbenkompressor (43) gemäß Anspruch 2, bei dem sich die Trennwände (107) von den Abschnitten der Seitenwand (103) erstrecken, wobei die Abschnitte in einem gleichwinkligen Abstand voneinander beabstandet sind.
4. Ein Kolbenkompressor (43) gemäß Anspruch 1, der ferner einen Rotations-Umwandlungsmechanismus zum Umwandeln der Rotationsbewegung einer drehbaren Welle (55) in die hin- und hergehende Bewegung der Kolben in der Richtung der drehbaren Welle aufweist, wobei der Rotations-Umwandlungsmechanismus einer ist, der aus einem Dreh-Taumelscheibenmechanismus und einem Wobbelscheibenmechanismus ausgewählt wird.
5. Ein Kolbenkompressor (43) gemäß Anspruch 1, wobei der Zylinderkopf (49) aus zwei Teilabschnitten in einer axialen Richtung gebildet wird, wobei einer der Teilabschnitte mit einer Auslaßkammer (131) und einem Durchgangsloch (127) versehen ist, während ein anderer mit Hohlräumen (109), die voneinander durch Trennwände (107) unterteilt sind, versehen ist.

Revendications

1. Compresseur (43) du type à mouvement alternatif, comprenant
 un bloc-cylindres (49) dans lequel sont formés plusieurs alésages de cylindres (45),
 plusieurs pistons (81) reçus dans lesdits alésages

sages de cylindres, respectivement,

une culasse (87) reliée audit bloc-cylindres et présentant un orifice d'introduction d'un réfrigérant (105) ;

une chambre d'aspiration (109, 111, 123) prévue dans ladite culasse et reliant ledit orifice d'introduction d'un réfrigérant auxdits alésages de cylindres, ledit compresseur comprimant un fluide introduit dans lesdits alésages de cylindres par le mouvement alternatif desdits pistons dans lesdits alésages de cylindres, ladite culasse comprenant des parois de séparation (107) s'étendant sensiblement radialement vers l'intérieur à partir d'une paroi latérale de la culasse, en direction de l'orifice d'introduction d'un réfrigérant, divisant ladite chambre d'aspiration en chemins pour un fluide, pour introduire le fluide dans les alésages de cylindres correspondants, **caractérisé en ce que**

un vide (111) dans la chambre d'aspiration est formé par les parties d'extrémité de la longueur des parois de séparation (107), et est formé près de l'orifice (105) à réfrigérant, avec une forme biseautée de telle sorte que la surface de la section transversale définie par chacune des parties d'extrémité de la longueur des parois de séparation augmente progressivement vers l'intérieur, et plusieurs plis en saillie (107a) sont formés sur les parties d'extrémité de la longueur des surfaces des parois de séparation.

5

10

15

20

25

30

2. Compresseur (43) du type à mouvement alternatif selon la revendication 1, dans lequel lesdites parois de séparation (107) s'étendent à partir de portions d'une paroi latérale (103) de la culasse en direction dudit orifice (105) d'introduction d'un réfrigérant. 35
3. Compresseur (43) du type à mouvement alternatif selon la revendication 2, dans lequel lesdites parois de séparation (107) s'étendent à partir des parties de la paroi latérale (103), les parties étant écartées l'une de l'autre d'un intervalle équiangulaire. 40
4. Compresseur (43) du type à mouvement alternatif selon la revendication 1, comprenant en outre un mécanisme de transformation d'une rotation, pour transformer le mouvement rotatif d'un arbre rotatif (55) en le mouvement alternatif desdits pistons dans la direction dudit arbre rotatif, ledit mécanisme de transformation d'une rotation étant un mécanisme choisi parmi un mécanisme à came plate et un mécanisme à plateau oscillant. 45
50
5. Compresseur (43) du type à mouvement alternatif selon la revendication 1, dans lequel la culasse (49) est constituée de deux portions divisionnaires dans une direction axiale, l'une desdites portions divisionnaires étant pourvue d'une chambre de décharge (131) et d'un orifice traversant (127), une autre

35

40

45

50

55

étant pourvue de vides (109) séparés l'un de l'autre par des parois de séparation (107)

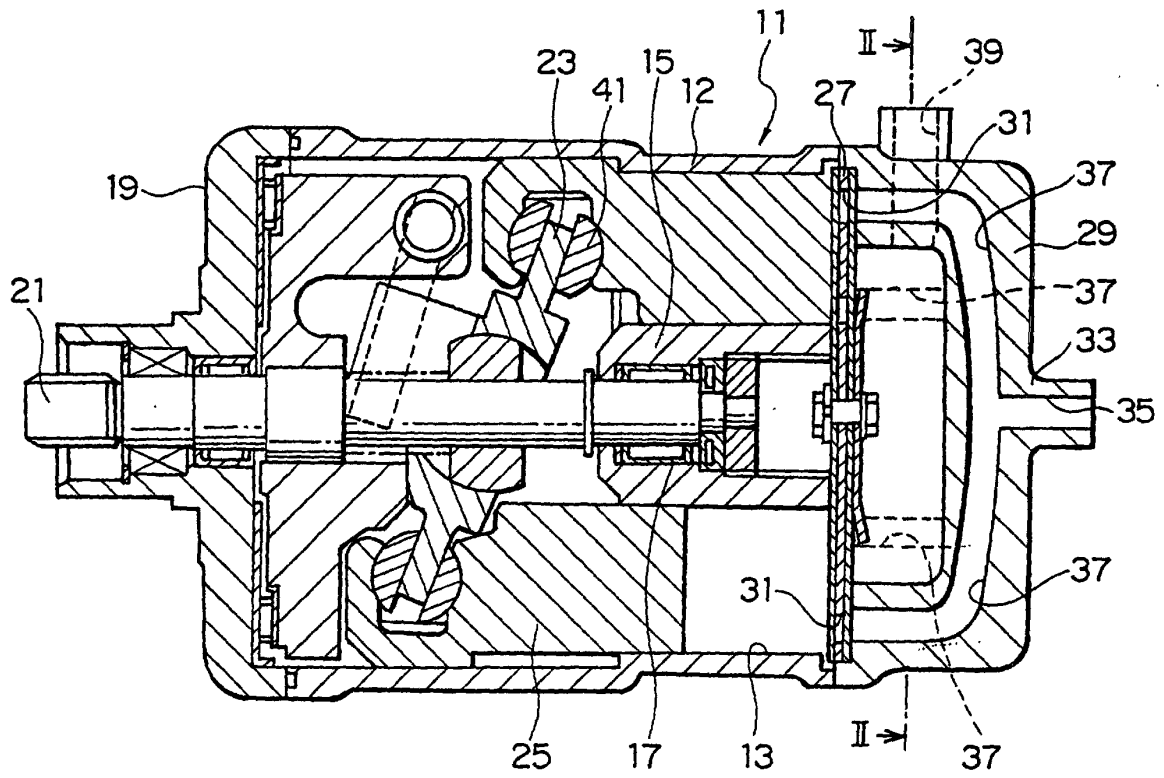

FIG. 1 PRIOR ART

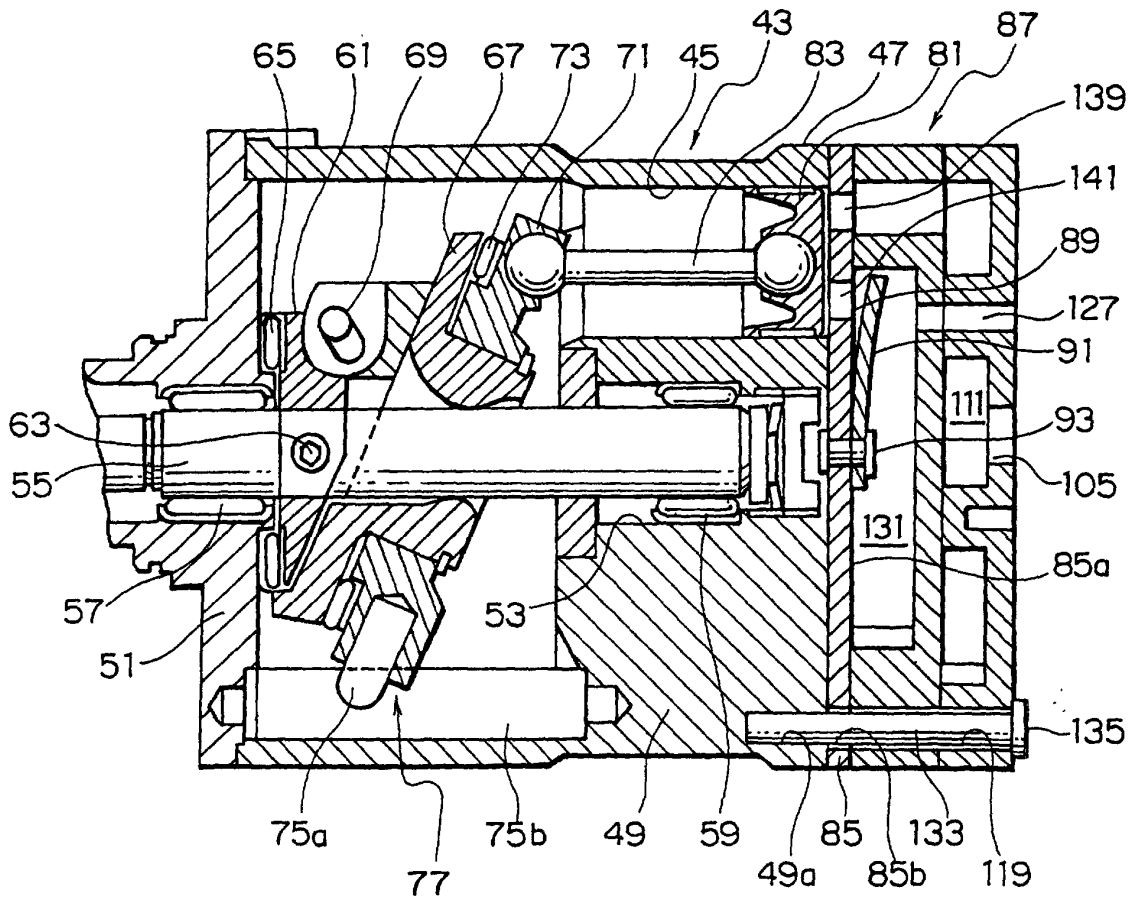

FIG. 3

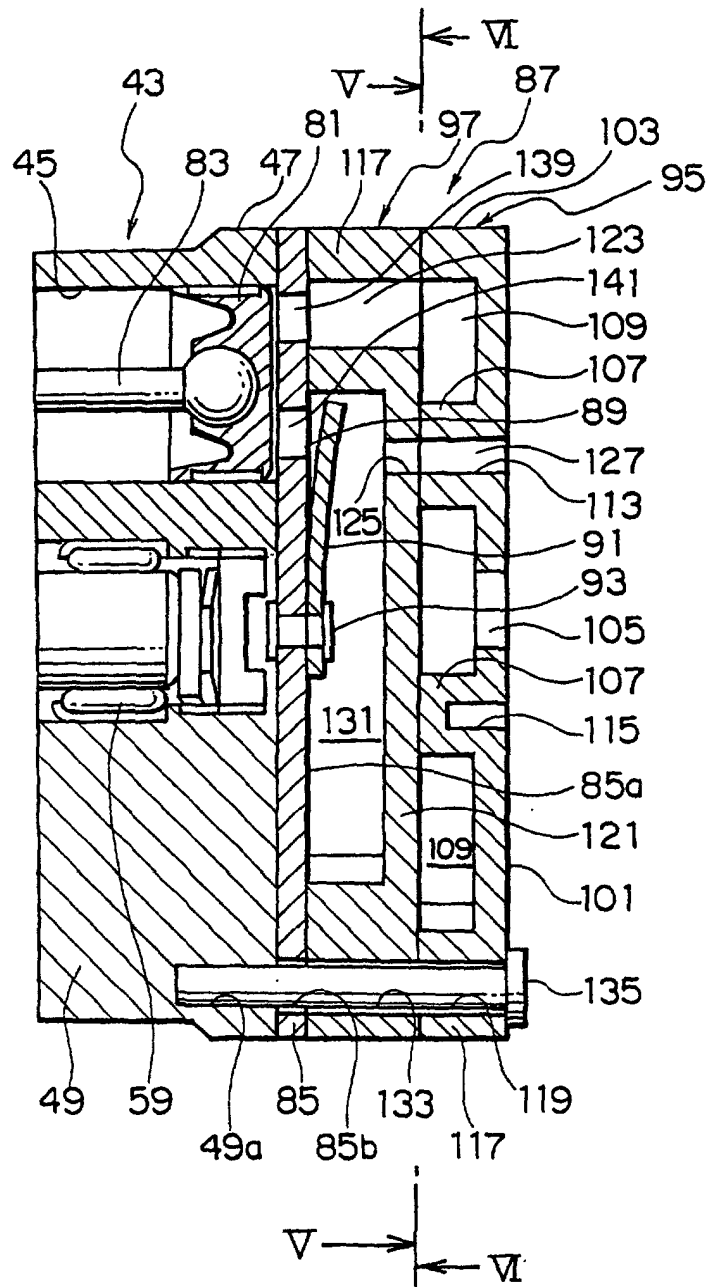

FIG. 4

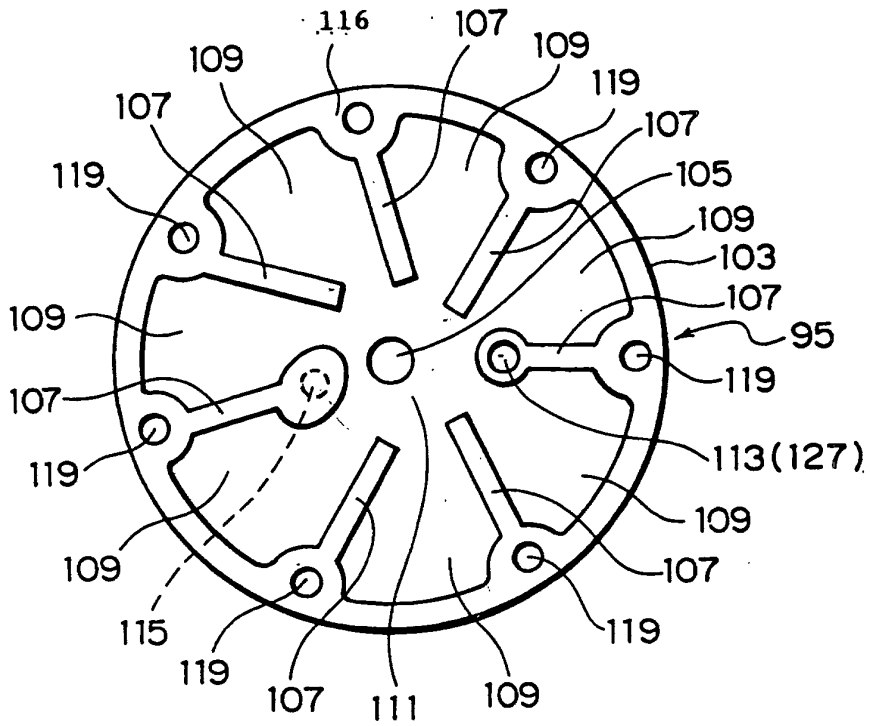

FIG. 5

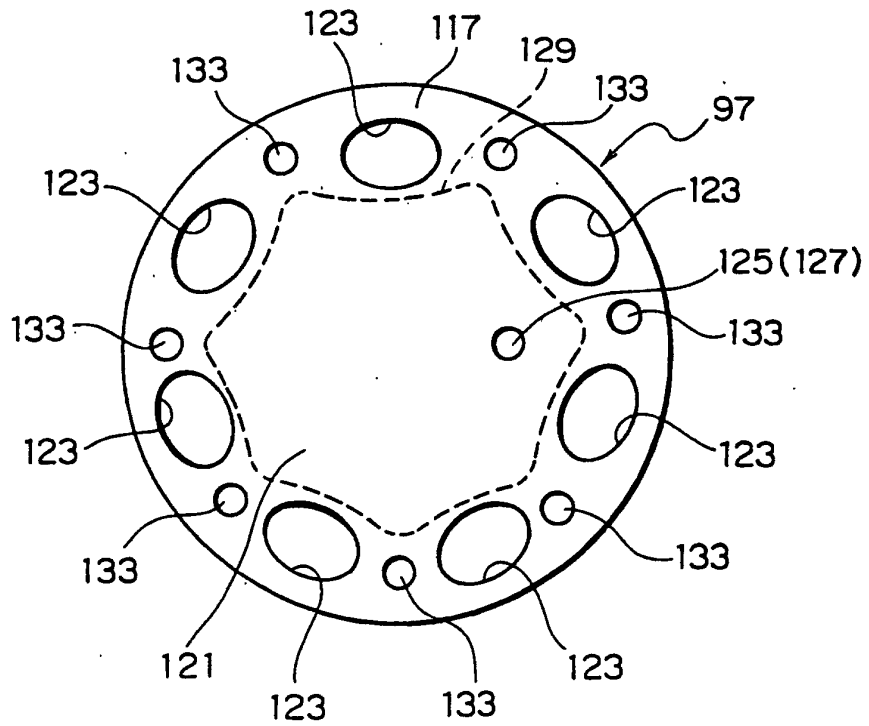

FIG. 6

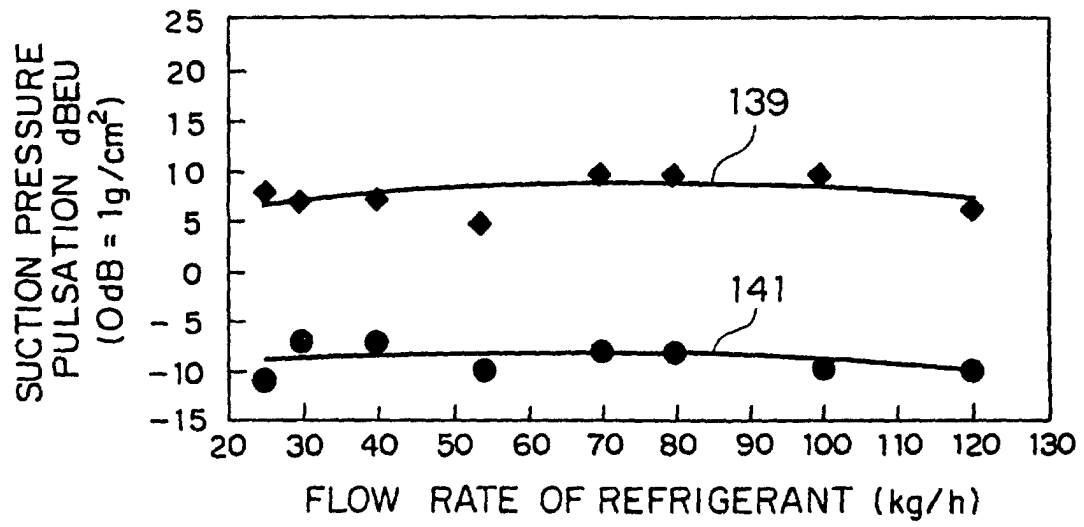

FIG. 7

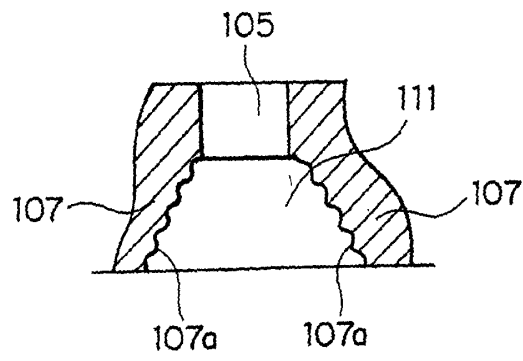

FIG. 8A

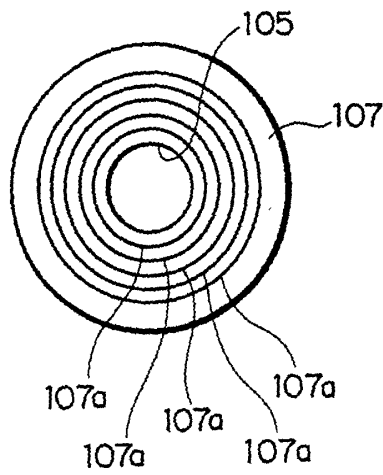

FIG. 8B

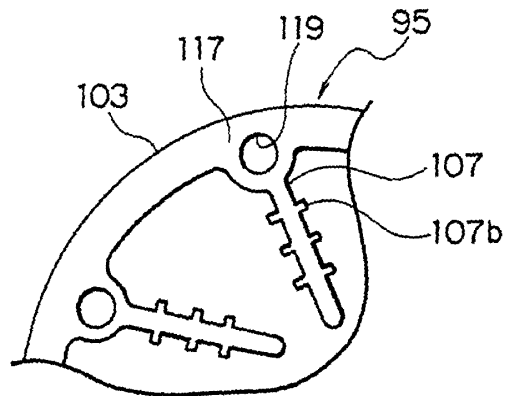

FIG. 9