



Europäisches Patentamt
European Patent Office
Office européen des brevets



(11) **EP 1 052 181 B1**

(12) **EUROPEAN PATENT SPECIFICATION**

(45) Date of publication and mention
of the grant of the patent:
13.08.2003 Bulletin 2003/33

(51) Int Cl.7: **B65D 17/50, B65D 51/20**

(21) Application number: **99201459.7**

(22) Date of filing: **12.05.1999**

(54) **Can for granular food products with selective dosing system**

Behälter für Nahrungsmitteln mit auswählbarem Dosiersystem

Boîte pour aliments avec système de dosage sélectif

(84) Designated Contracting States:
**AT BE CH DE DK ES FI FR GB GR IE IT LI LU NL
PT SE**

(72) Inventor: **Vendrig, Arie J.**
8601 ZH Sneek (NL)

(43) Date of publication of application:
15.11.2000 Bulletin 2000/46

(74) Representative: **Borne, Patrice Daniel et al**
Avenue Nestlé 55
1800 Vevey (CH)

(73) Proprietor: **Société des Produits Nestlé S.A.**
1800 Vevey (CH)

(56) References cited:
EP-A- 0 510 488 **US-A- 3 441 167**
US-A- 4 936 494 **US-A- 5 688 544**

EP 1 052 181 B1

Note: Within nine months from the publication of the mention of the grant of the European patent, any person may give notice to the European Patent Office of opposition to the European patent granted. Notice of opposition shall be filed in a written reasoned statement. It shall not be deemed to have been filed until the opposition fee has been paid. (Art. 99(1) European Patent Convention).

Description

[0001] The present invention relates to a container assembly that allows the storage and dispense of powder food products. The invention pertains to the art of can and closure means, more specifically to a system for selectively dispensing powders from a can or similar containers.

[0002] Containers for powdered and granular food products are known to the consumer. They are a convenient way of storing and preserving food and, of course, are well known in every household. Many of these containers are large and cylindrical in configuration and incorporate an aluminium foil or film to hermetically seal an open top of the container. The containers have usually a large top aperture. A typical can has a diameter of about 85 to 110 mm and has a storage capacity of about 200 to 500 grams depending upon the specific gravity of the granular material therein.

[0003] Millions of such containers are daily used throughout the world. When such containers are used for materials having a powder or granular consistency, such as baby formula, cereals, coffee, cocoa and the like, after the opening of the foil or film, the user may want to take a scoop to dose the desired quantity of food product. Sometimes, the scoop is already included inside the container. Another category of users wants to perform the dosing of the powder by directly pouring the powder through the large aperture generally causing imprecise and messy results. A significant loss of product can also be undergone when, for example, narrow necked baby bottles have to be filled with cereals, milk powder, etc.

[0004] US Patent 5,443,174 to Bauer relates to a zip-top can with a top having the contour of a spoon integral with upper surface of the top. The contour of the spoon is formed by a weakened edge and with the end of the spoon handle being attached to a pull-tab used for removing the spoon.

[0005] Australian patent 85964/82 relates to an easy opening can with two pull tabs. One pull tab is to open the hole for dispensing the beverage, the other pull tab is to open a little opening for drawing air.

[0006] US Patent 5,695,085 to Hadener relates to a beverage can with a single pull tab enable to open two different openings, one for beverage, the second for admitting air.

[0007] GB 2 204 554 relates to a compartment pull-open can separated into two compartments. Two pull tabs on the top and the bottom of the can enable to open separately the upper or the lower part of the can.

[0008] DE 36 18 836 relates to a drink can with sectioned construction. The can is separated vertically in two compartments. Two pull tabs on the top enable to open separately the right or the left part of the can.

[0009] DE 195 41 416 relates to a container or can for drinks having at least one dividing wall to form two or more useful cavities, each capable of being opened sep-

arately by the user.

[0010] GB 2 265 597 relates to a can with two chamber and one ring-pull. The can is separated vertically in two compartments. A single pull-tab enable to open separately the two parts of the can.

[0011] WO 9903742 relates to a device for opening beer and beverage cans which comprises a large pull tab to open the entire top can.

[0012] US 5,494,184 to Noguchi relates to a can top with an overturnable tab so as to allow two different portions of the can to be opened with that single tab.

[0013] US-A-4 936 494 shows a container for spices et condiments having a shake-and-spoon cap. The cap is provided with a spoon opening and a plurality of shaker openings, which are selectively closed by two hinged flaps. The preamble of claim 1 is based on this document.

[0014] None of the prior art set forth above shows or even suggests the invention described herein.

[0015] Notwithstanding the progress made in the canning art, it still does not exist a dispensing system that fulfils the various needs and habits of the users for such relatively large powdered food containers.

[0016] The present invention contemplates a new and improved container, which is simple in design, effective in use, and overcomes the foregoing difficulties. In particular, one of the objects of the invention is to give the choice to the user to dispense the food product either by way of a dosing tool or by directly pouring the food product in an efficient and precise way.

[0017] For that the present invention provides a can type container assembly for storage and dosing a powdered or granular pourable food product wherein it comprises a container body (2) having a bottom wall (5), a peripheral wall (4) and a top wall (6); the top wall (6) having at least two separate apertures (80, 81); a first aperture (80) and the other second aperture (81) having a section larger than the first aperture so as to allow a dosing tool to be freely engaged therein, at least one closure means (7) attached onto the top wall (6) arranged to cover the two apertures characterized in that

the first aperture (80) has a section adapted for dosing by pouring of the food product through the aperture and,

the closure means (7) comprises a removable foil hermetically and individually sealing the two apertures and in that means (71) for removing the closure means (7) are arranged in a position to uncover entirely the first aperture (80) before the second aperture (81) is uncovered so as to allow dosing from the first aperture (80) while the second aperture (81) remains hermetically sealed.

[0018] In a preferred embodiment, the closure means is unitary and covers both the first and second apertures. Therefore, the closure means can be easily pulled out so as to allow one of the apertures to be uncovered as desired while the other one remains properly covered

by the closure means. This solution is more cost effective as it simplifies the arrangement and reduces the number of pieces.

[0019] In an alternative, each aperture is covered by a separate closure means. In this cleaner solution, it is avoided any > portion of closure means in an unsealed configuration attached to the top wall of the container.

[0020] Therefore, the user can have a first access to the smaller aperture so as to be able to pour the food product in a precise manner while keeping the larger access closed to prevent any accidental leak of product while pouring. The smaller access is preferably sized to properly fit narrowly necked containers such as baby bottles or similar items.

[0021] The closure means is a sealing foil. The foil is preferably sealed onto the upper surface of the top wall along at least a peelable sealing rim which encompasses the two apertures. Consequently, the closure means provides a suitable safety closure as well as an easy opening system. Storage of shelf stable food products can be contemplated as the closure means gives all guarantees of freshness of the container's content.

[0022] In another preferred aspect of the container assembly of the invention, an inner peelable sealing cord is provided which extends between the first and second apertures while connecting the outer sealing rim. Therefore, two distinct hermetically sealed portions are defined on the top wall so as to permit the individual opening of one of the aperture while the other can remain hermetically sealed.

[0023] The invention will be more fully understood from the following description of specific embodiments thereof.

[0024] In the accompanying drawings,

FIG. 1 is a perspective view of a dispensing container according to the present invention;

FIG. 2 is a top view of the container according to FIG. 1;

FIG. 3 is a top view of the container after partial removal of the closure means;

FIG. 4 is a top view of the container after total removal of the closure means;

FIG. 5 is a cross sectional view of the top part of the dispenser along line A-A of FIG. 2;

FIG. 6 is a top view of the container similar to FIG. 2 but according to a variant of the invention.

[0025] With reference to FIG. 1, a container assembly according to the present invention is generally designated by reference numeral 1. The container assembly will be named "can" in the following description for simplification of language of the description. However, it must

be noted that the container assembly can have various shapes and dimensions other than those schematically depicted in FIG. 1.

[0026] The can 1 comprises a main body 2 and a removable lid 3. The body has a peripheral wall 4 which connects a bottom wall 5 to a top wall 6. The peripheral wall could be of any shapes such as cylindrical, cubic, rectangular, etc. The peripheral wall defines a single interior volume wherein the food product is stored. In the figure, the body is of a standard can design, generally used for powdered or granular air-sensitive materials. The can can be filled with about 200 to 500 grams of powder depending upon the size of the can and the specific gravity of the powder. The height of the can is generally comprised between about 118 to 159 mm and the diameter is about 90 to 110 mm. The body is generally made of metal, preferably tinplate or aluminium. The top wall is at least partly covered by a closure means, preferably a hermetically sealed foil 7 as it will be explained later on. The lid 3 is mounted in covering relation over the top of the container body. The lid generally comprises a substantially plate portion 30 extending downwardly by an annular edge 31, which is intended to engage the upper edge or seam 40 of the body. The lid so protects the sealed foil from accidental puncturing which would cause spoilage or deterioration of the food content.

[0027] As shown in FIG. 2, the top wall can be a tinplate part assembled to the peripheral wall by a folded or crimped arrangement well known in the art of can manufacturing. In the presently illustrated view, the wall is shown in a flat arrangement before being crimped to the peripheral wall. Therefore, the top wall comprises an edge 60 intended to be shaped like a sort of crook to join the peripheral wall with a complementary crook. The top wall further comprises a top surface 61 in a slightly lowered level with respect to the raised edge 60 when assembled to form the body.

[0028] A closure means 7, which is a peelable foil, is removably attached to the top surface 61 of the top wall. As shown in FIG. 4 and 5, the top surface is provided with two apertures 80, 81 spaced apart on the surface. The two apertures give access to the same interior volume of the can. A first aperture 80 has a small section adapted for dosing the pourable food product contained in the can. A second aperture 81 is provided which is greater than the first one. The section of it is adapted for the passage of a dosing tool. As dosing tool, it is intended items such as scoop, spoon, short stick, rod, etc. The first aperture will have a section between about 80 to 700 mm² whereas the second aperture will have a section of about 1500 to 4000 mm². The section may vary as a function of the granulometry of the food product and also as a function of the size and shape of the can.

[0029] As the second aperture is relatively large compared to the first aperture, it is desirable to protect the user from being cut by the edges of the aperture. For

that the second aperture comprises inward rounded edges 82. The first aperture has preferably flat edges as the powder has to be poured in a continuous controllable flow. A rounded edge would break the flow that would lead to problems in ensuring an accurate dosage for the user.

[0030] The closure means 7 comprises a main covering portion 70 and a pull tab portion 71 which connects to the covering portion. The pull tab portion is preferably integral with the covering portion and made of the same material. In the storage configuration with the lid thereon, the closure means has its tab portion folded inwardly as shown in FIG. 2 and 5. When the closure means is opened, the tab portion is lifted and a traction force is exerted upon the closure means in the direction shown by arrow B of FIG. 3; i.e., in direction opposite to the direction of extension of the tab when outwardly deployed. The first aperture 80 is located in the vicinity of the tab portion; i.e., along the substantially same radial direction, so that when the pull tab portion is pulled upon removal, the first aperture is uncovered before the second aperture. It is advantageous that the pull tab comprises a ring or any other suitable prehension means.

[0031] Preferably, the shape of the first aperture 80 resembles an elongated slot radially oriented in the same direction as the pull tab portion. The first aperture could take many other various types of sections such as round, square, etc. A series of distinct smaller holes may also replace the single first aperture as an alternative to the invention. However, the size of the holes must be adapted to the type of powders to be dispensed so as to promote an efficient dosage.

[0032] In the event the closure means 7 is a sealed foil as shown in the figures, the foil is preferably sealed to the top surface 61 of the top wall by means of a peripheral sealing rim 90. The rim is a peelable seal which adheres to both the inner surface of the foil and to the top surface of the wall in a removable manner. The rim preferably encompasses the contour of the both apertures 80, 81 so as to keep an air-tight inner volume for the food product. Preferably the rim is a substantially circular rim positioned close to the external contour of the foil. The rim has a width of about 1 to 5 mm so as to confer sufficient adhering properties. Of course, the dimensions and size of sealing foil may vary depending on the dimensions and shapes of the apertures. The rim may also have shape slightly different from a round.

[0033] In an important feature of the invention, an additional inner peelable sealing cord 91 is provided which extends between the two apertures. The additional sealing cord 91 so defines a first individual hermetically sealed portion 92 encompassing the first aperture and a second individual hermetically sealed portion 93 encompassing the second aperture 82. Therefore, such an arrangement permits to open the first portion with the smaller aperture to perform the dosage of the food product by pouring while the second portion with the larger aperture remains impermeably closed. In an alternative

(not shown), two separate independent sealing rims may be provided, each one individually surrounding an aperture.

[0034] In such configurations, the can may be so manipulated without risking spilling food product through the large aperture. A variety of foil materials which are currently available meets the demand of the present invention. Aluminium or aluminium alloy is preferred with or without an interior plastic coating. Means for marking the underlying location can advantageously be provided on the foil or closure means so that the user can instantaneously identify the location, contour and size of the apertures. FIG. 2 and 5 illustrates structural imprints 76, 77 made in the metal thickness of the foil. Other types of marking could be used such as designs or patterns produced in relief or not.

[0035] FIG. 6 illustrates another embodiment in which the apertures are covered by separate closure means 7a, 7b. Each closure means can be a separate sealing foil independently sealed on the top surface 61. For that, each foil is removably connected to the surface by a continuous seal 90a, 90b which encompasses its respective aperture. This permits to ensure an air-tight arrangement of the can before the first use while authorising the choice for opening any of the two apertures as more desired by the user. It also eliminates the partly peeled portion 75 of the foil as depicted in FIG. 3. Preferably, each closure means comprises a separate tab portion 71a, 71b for independently removing each closure means. In an alternative, each closure means may closely be adapted to the dimensions and form of the aperture which it covers.

[0036] While the invention has been described with regard to specific embodiments, it should be noted that various modifications might be made without departing from the scope of the invention. For example, the number, size and location of the apertures could vary depending upon various conditions such as the type of containers, the type of food products to be stored, etc.

Claims

1. A can type container assembly for storage and dosing a powdered or granular pourable food product wherein it comprises

a container body (2) having a bottom wall (5), a peripheral wall (4) and a top wall (6); the top wall (6) having at least two separate apertures (80, 81); a first aperture (80) and the other second aperture (81) having a section larger than the first aperture so as to allow a dosing tool to be freely engaged therein, at least one closure means (7) attached onto the top wall (6) arranged to cover the two apertures **characterized in that**

- the first aperture (80) has a section adapted for dosing by pouring of the food product through the aperture and, the closure means (7) comprises a removable foil hermetically and individually sealing the two apertures and **in that** means (71) for removing the closure means (7) are arranged in a position to uncover entirely the first aperture (80) before the second aperture (81) is uncovered so as to allow dosing from the first aperture (80) while the second aperture (81) remains hermetically sealed.
2. A container assembly according to claim 1, wherein the closure means (7) is unitary and covers both the first and second apertures (80, 81).
3. A container assembly according to claims 1 or 2, wherein the closure means (7) is a unitary removable foil sealed onto the upper surface (61) of the top wall (6) along at least a peelable sealing rim (90) which encompasses the two apertures (80, 81).
4. A container assembly according to any of claims 1 to 3, wherein the closure means (7) is a unitary removable foil sealed onto the upper surface (61) of the top wall (6) along two separated peelable sealing rims, each one individually encompassing one of the aperture (80, 81).
5. A container assembly according to any of the preceding claims, wherein said means for removing comprising a pull tab portion (71), connected with the closure means (7); a traction force is exerted to remove the closure means thereupon.
6. A container assembly according to claim 5, wherein, the first aperture (80) is positioned in the vicinity of the pull tab portion (71) and has the shape of an elongated slot radially oriented in the direction of the tab portion.
7. A container assembly according to claim 3, wherein the sealing rim (90) is separated by an inner peelable sealing cord (91) extending between the first and second apertures (80, 81) so as to respectively define a first individual hermetically sealed portion (92) encompassing the first aperture (80) and a second individual hermetically sealed portion (93) encompassing the second aperture (81).
8. A container assembly according to claim 1, wherein each aperture (80, 81) is covered by a separate closure means (7a, 7b).
9. A container assembly according to claim 8, wherein each closure means (7a, 7b) comprises a separate tab portion (71a, 71b) for independently removing each closure means.
10. A container assembly according to any of the preceding claims wherein means (76, 77) for marking the underlying location of the apertures (80, 81) are provided on the closure means (7).
11. A container assembly according to claim 10, wherein the means for marking includes structural imprints or designs defining the contour of the apertures.

15 Patentansprüche

1. Dosenartige Behälteranordnung zum Lagern und Dosieren eines pulverförmigen oder körnigen ausschüttbaren Lebensmittels, die

einen Behälterkörper (2) mit einer Bodenwand (5), einer Umfangswand (4) und einer Deckenwand (6) umfaßt, wobei die Deckenwand (6) zumindest zwei getrennte Öffnungen (80, 81) aufweist, eine erste Öffnung (80) und eine andere zweite Öffnung (81) mit einem Querschnitt, der größer als der der ersten Öffnung ist, damit ein Dosierwerkzeug frei dadurch eingreifen kann,

wobei zumindest eine Verschlussvorrichtung (7) an der Deckenwand (6) angebracht ist, die angeordnet ist, um die beiden Öffnungen abzudecken, **dadurch gekennzeichnet, daß**

die erste Öffnung (80) einen Querschnitt aufweist, der zum Dosieren des Lebensmittels durch Ausschütten durch die Öffnung angepaßt ist, und

die Verschlussvorrichtung (7) eine entfernbare Folie aufweist, die die beiden Öffnungen hermetisch und einzeln abdichtet, und dadurch, daß Mittel (71) zum Entfernen der Verschlussvorrichtung (7) an einer Stelle angeordnet sind, um die erste Öffnung (80) insgesamt freizulegen, bevor die zweite Öffnung (81) freigelegt wird, um das Dosieren aus der ersten Öffnung (80) zu ermöglichen, während die zweite Öffnung (81) hermetisch abgedichtet bleibt.

2. Behälteranordnung nach Anspruch 1, bei der die Verschlussvorrichtung (7) einstückig ist und sowohl die erste als auch die zweite Öffnung (80, 81) abdeckt.

3. Behälteranordnung nach Anspruch 1 oder 2, bei der

die Verschlussvorrichtung (7) eine einstückige entfernbare Folie ist, die auf die obere Oberfläche (81) auf der Deckenwand (6) entlang eines zumindest abziehbaren Dichtungsrandes (90) geschweißt ist, der die beiden Öffnungen (80, 81) einschließt.

4. Behälteranordnung nach einem der Ansprüche 1 bis 3, bei der die Verschlussvorrichtung (7) eine einstückige entfernbare Folie ist, die auf die obere Oberfläche (61) der Deckenwand (6) entlang von zwei getrennten abziehbaren Dichtungsrandern geschweißt ist, von denen jeder eine der Öffnungen (80, 81) umschließt.
5. Behälteranordnung nach einem der vorhergehenden Ansprüche, bei der die Mittel zum Entfernen einen Ziehverschlußabschnitt (71) aufweisen, der mit der Verschlussvorrichtung (7) verbunden ist, wobei eine Zugkraft ausgeübt wird, um die Verschlussvorrichtung davon zu entfernen.
6. Behälteranordnung nach Anspruch 5, bei der die erste Öffnung (80) in der Nähe des Ziehverschlußabschnitts (71) angeordnet ist und die Form eines länglichen Schlitzes aufweist, der radial mit der Richtung des Verschlußabschnitts ausgerichtet ist.
7. Behälteranordnung nach Anspruch 3, bei der der Dichtrand (90) durch eine innere abziehbare Dichtschnur (91) getrennt ist, die sich zwischen der ersten und der zweiten Öffnung (80, 81) erstreckt, um jeweils einen ersten einzeln hermetisch abgedichteten Abschnitt (92), der die erste Öffnung (80) einschließt, und einen zweiten einzeln hermetisch abgedichteten Abschnitt (93) zu definieren, der die zweite Öffnung (81) einschließt.
8. Behälteranordnung nach Anspruch 1, bei der jede Öffnung (80, 81) mit einer getrennten Verschlussvorrichtung (7a, 7b) abgedeckt ist.
9. Behälteranordnung nach Anspruch 8, bei der jede Verschlussvorrichtung (7a, 7b) einen getrennten Verschlußabschnitt (71a, 71b) zum unabhängigen Entfernen jeder Verschlussvorrichtung aufweist.
10. Behälteranordnung nach einem der vorhergehenden Ansprüche, bei der Mittel (76, 77) zum Markieren der darunterliegenden Stelle der Öffnungen (80, 81) auf der Verschlussvorrichtung (7) vorgesehen sind.
11. Behälteranordnung nach Anspruch 10, bei der die Mittel zum Markieren strukturelle Eindrücke oder Designs enthalten, die den Umriss der Öffnungen bestimmen.

Revendications

1. Ensemble formant conteneur de type boîte pour stockage et dosage d'un produit alimentaire en poudre ou en grains pouvant être versé, dans lequel l'ensemble comprend

un corps (2) de conteneur comportant une paroi inférieure (5), une paroi périphérique (4) et une paroi supérieure (6); la paroi supérieure (6) comportant au moins deux ouvertures distinctes (80, 81); une première ouverture (80) et l'autre deuxième ouverture (81) ayant une section plus grande que la première ouverture, de façon à permettre d'y engager librement un ustensile de dosage,

au moins un moyen (7) de fermeture fixé à la paroi supérieure (6), agencé pour couvrir les deux ouvertures, **caractérisé en ce que** la première ouverture (80) a une section conçue pour le dosage par versement du produit alimentaire par l'ouverture, et le moyen (7) de fermeture comprend une feuille amovible scellant hermétiquement et individuellement les deux ouvertures, et **en ce que** des moyens (71) destinés à retirer le moyen (7) de fermeture sont agencés dans une certaine position pour découvrir complètement la première ouverture (80) avant que la seconde ouverture (81) ne soit découverte, de façon à permettre le dosage à partir de la première ouverture (80), tandis que la seconde ouverture (81) demeure hermétiquement scellée.

2. Ensemble formant conteneur selon la revendication 1, dans lequel le moyen (7) de fermeture est d'une seule pièce et couvre les deux, première et deuxième, ouvertures (80, 81).
3. Ensemble formant conteneur selon les revendications 1 ou 2, dans lequel le moyen (7) de fermeture est une feuille amovible d'une seule pièce scellée sur la surface supérieure (61) de la paroi supérieure (6) le long d'au moins un rebord (90) de scellement pouvant être arraché qui entoure les deux ouvertures (80, 81).
4. Ensemble formant conteneur selon l'une quelconque des revendications 1 à 3, dans lequel le moyen (7) de fermeture est une feuille amovible d'une seule pièce scellée sur la surface supérieure (61) de la paroi supérieure (6) le long de deux rebords distincts de scellement pouvant être arrachés, chacun entourant individuellement l'une des ouvertures (80, 81).
5. Ensemble formant conteneur selon l'une quelconque des revendications précédentes, dans lequel

ledit moyen de retrait comprend une partie (71) formant patte de traction reliée au moyen (7) de fermeture ; dans lequel on exerce une force de traction pour retirer le moyen de fermeture.

5

6. Ensemble formant conteneur selon la revendication 5, dans lequel la première ouverture (80) est placée à proximité de la partie (71) formant patte de traction et a la forme d'une fente allongée orientée radialement dans la direction de la partie formant patte.
7. Ensemble formant conteneur selon la revendication 3, dans lequel le rebord (90) de scellement est séparé par un cordon intérieur (91) de scellement pouvant être arraché s'étendant entre les première et deuxième ouvertures (80, 81), de façon à définir respectivement une première partie individuelle hermétiquement scellée (92) entourant la première ouverture (80), une deuxième partie individuelle hermétiquement scellée (93) entourant la deuxième ouverture (81).
8. Ensemble formant conteneur selon la revendication 1, dans lequel chaque ouverture (80, 81) est couverte par un moyen (7a, 7b) de fermeture distincte.
9. Ensemble formant conteneur selon la revendication 8, dans lequel chaque moyen (7a, 7b) de fermeture comprend une partie (71a, 71b) formant patte distincte pour retrait indépendant de chaque moyen de fermeture.
10. Ensemble formant conteneur selon l'une quelconque des revendications précédentes, dans lequel des moyens (76, 77) de marquage de l'emplacement sous-jacent des ouvertures (80, 81) sont prévus sur le moyen (7) de fermeture.
11. Ensemble formant conteneur selon la revendication 10, dans lequel le moyen de marquage comprend des empreintes ou dessins structuraux définissant le contour des ouvertures.

10

15

20

25

30

35

40

45

50

55

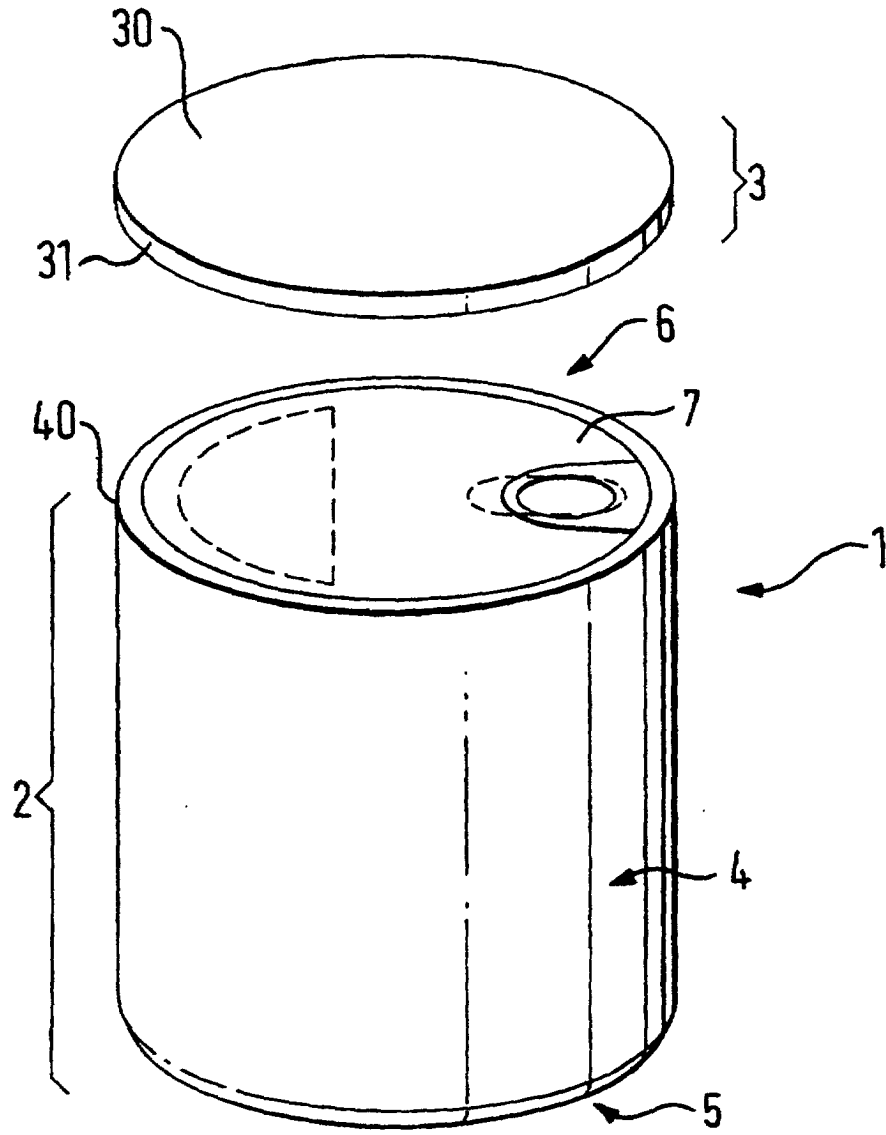

FIG. 1

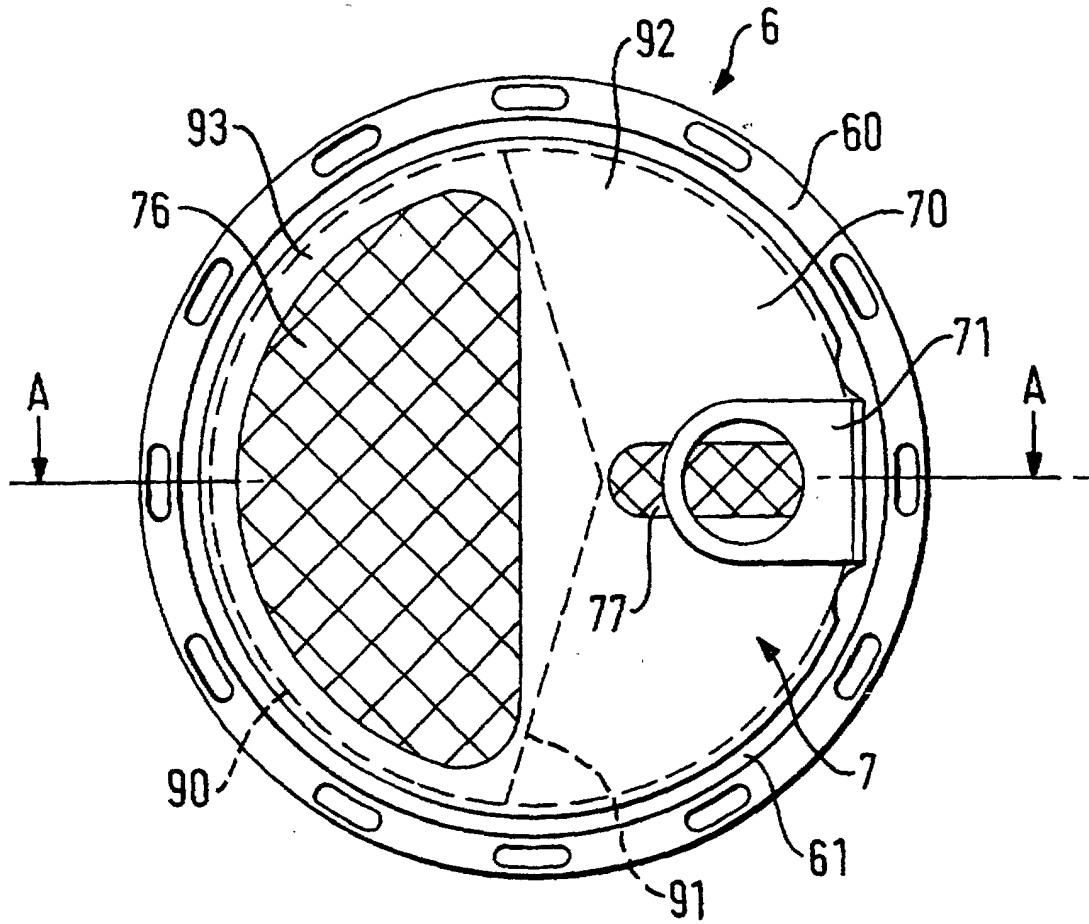

FIG. 2

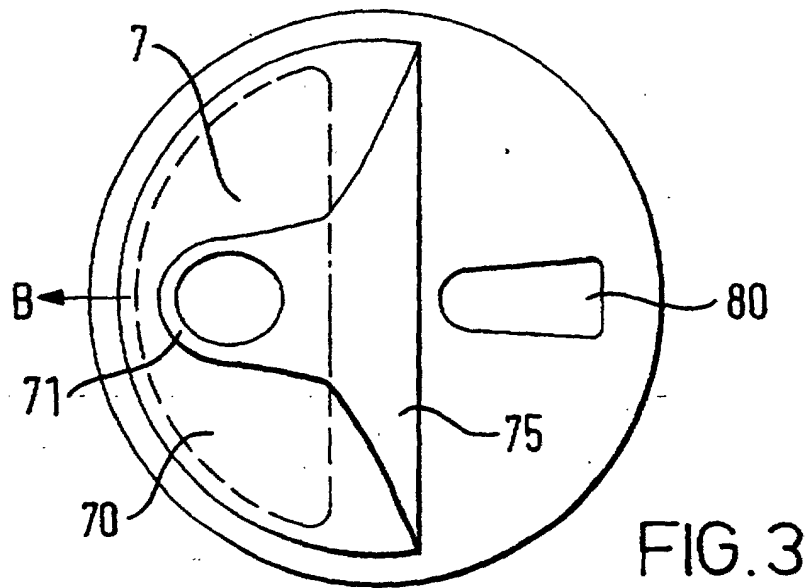

FIG. 3

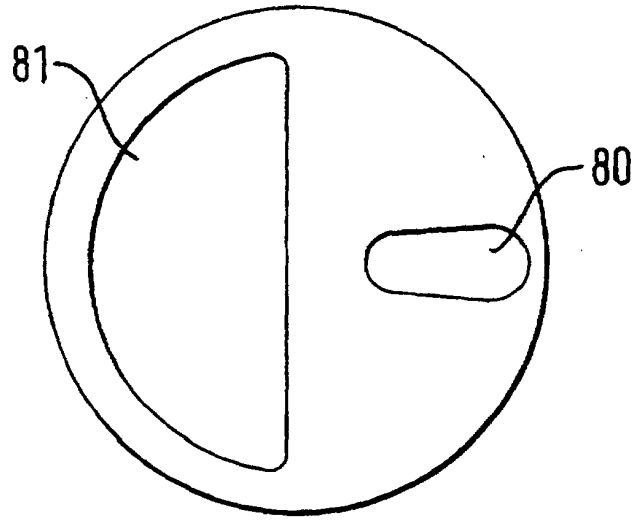

FIG. 4

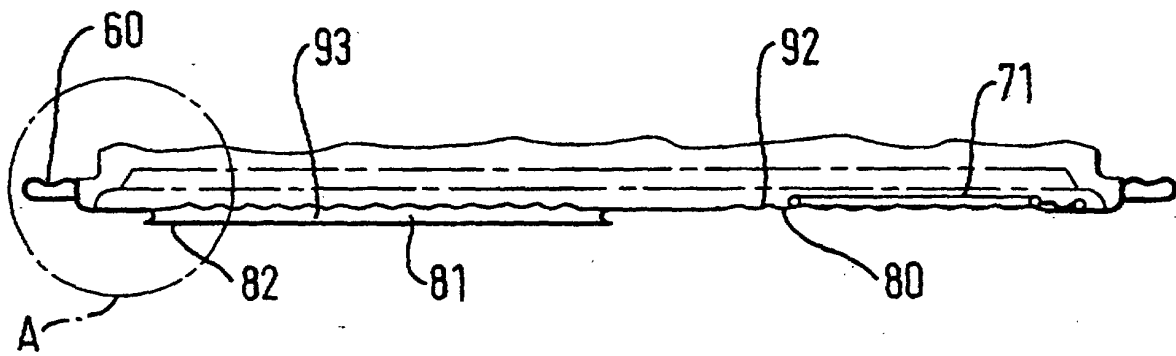

FIG. 5

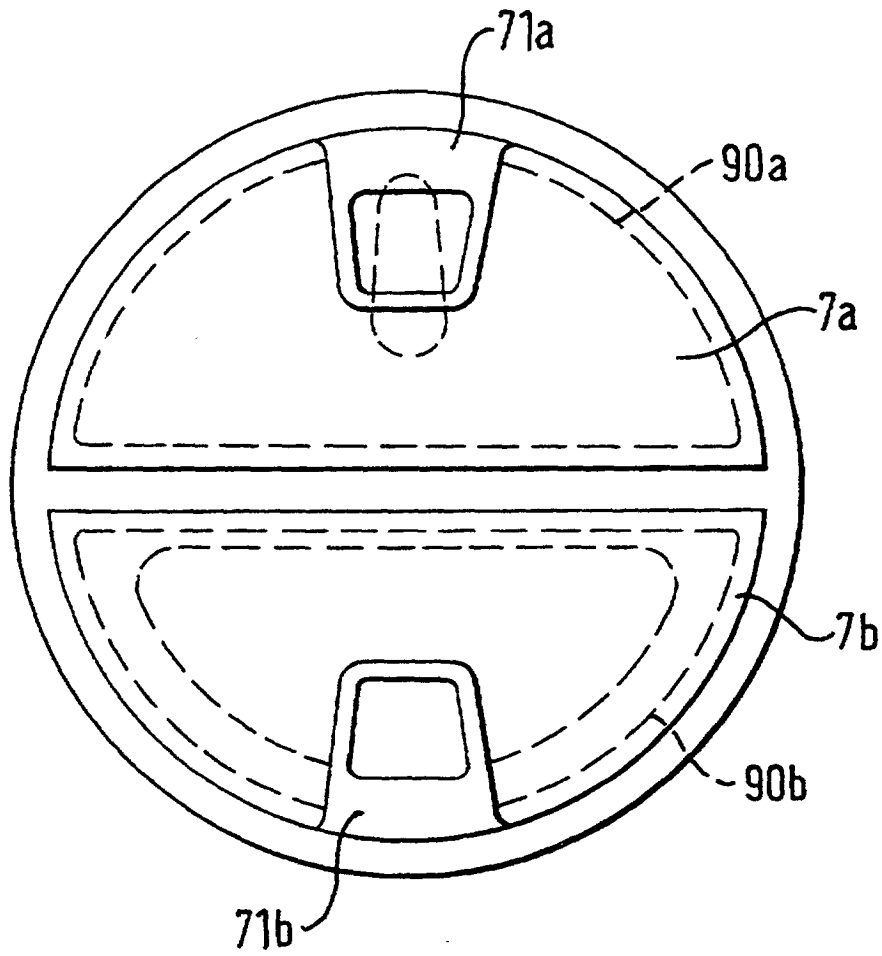

FIG. 6