



Europäisches Patentamt
European Patent Office
Office européen des brevets



(11) **EP 1 080 675 A1**

(12) **EUROPEAN PATENT APPLICATION**
published in accordance with Art. 158(3) EPC

(43) Date of publication:
07.03.2001 Bulletin 2001/10

(51) Int. Cl.⁷: **A47H 13/14**

(21) Application number: **99919520.9**

(86) International application number:
PCT/JP99/02201

(22) Date of filing: **26.04.1999**

(87) International publication number:
WO 99/55208 (04.11.1999 Gazette 1999/44)

(84) Designated Contracting States:
DE GB IT

(72) Inventor: **SUZUKI, Ken**
Atsugi-shi, Kanagawa 243-0813 (JP)

(30) Priority: **24.04.1998 JP 13128398**
10.02.1999 JP 3318599

(74) Representative:
Grünecker, Kinkeldey,
Stockmair & Schwanhäusser
Anwaltssozietät
Maximilianstrasse 58
80538 München (DE)

(71) Applicant: **NHK SPRING CO.LTD.**
Yokohama-shi, Kanagawa 236-0004 (JP)

(54) **CURTAIN HANGING DEVICE**

(57) A curtain hanger (10) capable of laterally holding a pleat portion (21) formed by folding a curtain (20), comprises a holding portion including holding plates (1, 2) for clamping the pleat portion (21) of the curtain (20) from both sides in the thickness direction thereof, a clip portion (4) including arms (4a, 4b) for maintaining the holding state of the holding plates (1, 2), a hook portion (3) capable of being hung on a runner sliding along a curtain rail, and straps (8) connecting the holding plates (1, 2) and the clip portion (4). The holding plates (1, 2), hook portion (3), clip portion (4), and straps (8) are molded integrally with one another from a synthetic resin.

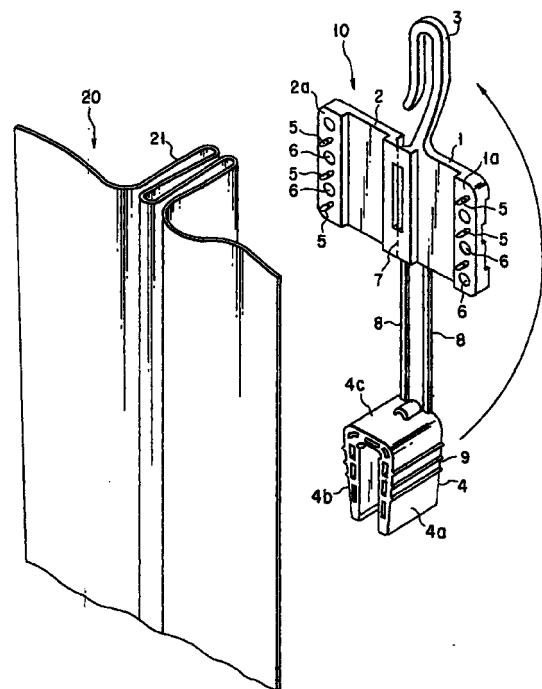

FIG. 1

EP 1 080 675 A1

Description

Technical Field

[0001] The present invention relates to a curtain hanger, and more particularly, to a curtain hanger for holding a curtain for suspension.

Background Art

[0002] FIG. 22 shows a conventional curtain hanger 30. In this curtain hanger 30, a hook portion 31 capable of being hung on a runner 51 that slides along a curtain rail 50 and an upward insertion rod 32 are formed integrally from a spring-steel wire or synthetic resin. The insertion rod 32 is inserted from below into a pocket portion 22 between seams 23a and 23b of a cloth belt 33 that is sewn to a curtain 20 along its upper end.

[0003] FIGS. 23A and 23B show another conventional curtain hanger 40. This curtain hanger 40 comprises a guide rod 41 provided with ratchet teeth 44, a hook portion 42 attached to the guide rod 41 so as to be adjustable in height and capable of being hung on the aforesaid runner (not shown), and an insertion rod 43 capable of being inserted from below into the gap of a pleat portion 21 of the curtain 20.

[0004] In these conventional curtain hangers 30 and 40, the pleat portions 21 must be formed at given intervals in the lateral direction of the curtain 20. In forming these pleat portions 21, the upper edge portion of the curtain 20 is folded in zigzags for a given length, and thereafter, it is tacked down by means of a needle or thread, and the pleat portions 21 are further sewn by means of a sewing machine. Alternatively, a tape having pleating pockets arranged thereon at equal spaces is sewn by a sewing machine to the upper edge portion of the curtain. After a desired number of pleating pockets are joined together, pleating claws as many as the pockets are inserted individually into the pockets, whereupon a plurality of pleat portions 21 are formed. Thus, in either case, the sewing operation is very troublesome, and the sewing operation also requires considerable skilled labor.

[0005] In the conventional curtain hanger 30 or 40, moreover, the insertion rod 32 or 43 is inserted into the pocket portion 22 between the seams 23a and 23b or the gap of the pleat portion 21. Therefore, the curtain hanger 30 or 40 may touch the tread with which the cloth 33 or the pleat portion 21 is sewn or the weight of the curtain 20 may act on the tread with which the pleat portion 21 is sewn, so that the thread is liable to break early, thus causing deformation of pleats.

[0006] Since the conventional pleating is based on sewing, furthermore, the pleats can maintain their shape when they are washed. If the curtain is washed, therefore, the pleats cannot be easily cleaned inside.

[0007] Accordingly, the object of the present invention is to provide a curtain hanger capable of avoiding

formation of wrinkles on or damage to a curtain that is caused by the conventional curtain hangers, obviating the necessity of operation for sewing pleat portions or a tape to the curtain, and facilitating removal of stains from the curtain.

Disclosure of Invention

[0008] In order to achieve the above object, a curtain hanger of the present invention comprises clamping means for holding a pleat portion of a curtain to suspend the curtain. According to this invention, the curtain hanger clamps the pleat portion of the curtain, so that it can eliminate the possibility of formation of wrinkles or damage that may be caused when the curtain is hooked from below as in the cases of the conventional curtain hangers.

[0009] Further, a curtain hanger of the present invention comprises clamping means for clamping a pleat portion of a curtain laterally or from above to suspend the curtain. According to this invention, the curtain hanger clamps the pleat portion of the curtain laterally or from above, so that the pleat portion need not be formed by sewing, and therefore, the curtain having the pleat portion can be manufactured with ease.

[0010] A curtain hanger of the present invention comprises a holding portion for clamping a pleat portion of a curtain laterally or from above, a clip portion for keeping the pleat portion clamped by means of the holding portion, and a hook portion connected directly or indirectly to a curtain rail. According to this invention, the holding portion clamps the pleat portion of the curtain, and moreover, the clip portion keeps the pleat portion clamped by means of the holding portion. The holding portion and the clip portion are suspended from the curtain rail by means of the hook portion. Since this curtain hanger unites a function to suspend the curtain and a function to form the pleat portion on the curtain, the pleat portion need not be formed by sewing.

[0011] According to the present invention, the holding portion is provided with a pair of holding plates for holding the pleat portion of the curtain from both sides in the thickness direction thereof, and mating protrusions and recesses are formed on or in the respective opposed surfaces of the holding plates. According to this invention, the pleat portion of the curtain is clamped tight as the protrusions and recesses of the holding plates engage one another. Thus, the curtain can be prevented further securely from slipping or coming off.

[0012] Preferably, in the curtain hanger of the present invention, the holding portion and the clip portion are coupled to each other by means of flexible straps. According to this arrangement, the holding portion and the clip portion can be handled in one united body, so that handling is convenient, and the holding portion and the clip portion can be prevented from being lost. The holding portion, clip portion, and straps may be molded integrally from a synthetic resin.

[0013] According to the present invention, a retaining mechanism for preventing the clip portion from slipping off the holding portion is provided between the holding portion and the clip portion. According to this invention, the clip portion is fixed firmly to the holding portion by means of the retaining mechanism, so that the state of the pleat portion of the curtain clamped by means of the holding plates can be maintained further securely.

[0014] According to the present invention, the clip portion includes a pair of arms externally holding the holding portion and a portion connecting these arms. According to this invention, the pair of arms of the clip portion display spring properties and externally hold the holding portion, so that the pleat portion can be securely held by means of the holding portion, and the change of the thickness of a material can be coped with.

[0015] According to the present invention, the clip portion is in the form of a frame, and the holding portion is joined to the holding portion by being inserted into the frame-shaped clip portion. According to this present invention, the holding portion is inserted into the frame-shaped clip portion, so that the holding portion can be assembled to the clip portion with ease.

Brief Description of Drawings

[0016]

FIG. 1 is a perspective view showing a curtain hanger according to a first embodiment of the present invention and a part of a curtain;

FIG. 2 is a perspective view showing a state in which a holding portion of the curtain hanger shown in FIG. 1 is attached to the curtain;

FIG. 3 is a perspective view showing a state obtained immediately before a clip portion of the curtain hanger shown in FIG. 1 is fitted on the holding portion;

FIG. 4 is a perspective view showing a state in which the clip portion of the curtain hanger shown in FIG. 1 is fitted on the holding portion;

FIG. 5 is a perspective view of a curtain showing another example of use of the curtain hanger shown in FIG. 1;

FIG. 6 is a perspective view of a curtain hanger according to a second embodiment of the present invention;

FIG. 7 is a perspective view showing a state in which a holding portion of the curtain hanger shown in FIG. 6 is attached to a curtain;

FIG. 8 is a perspective view showing a state obtained immediately before a clip portion of the curtain hanger shown in FIG. 6 is fitted on the holding portion;

FIG. 9 is a perspective view showing a state in which the clip portion of the curtain hanger shown in FIG. 6 is fitted on the holding portion;

FIG. 10A is a perspective view showing holding plates with a hook portion of a curtain hanger according to a third embodiment of the present invention;

FIG. 10B is a perspective view showing a state obtained immediately before a clip portion is fitted on the holding plates shown in FIG. 10A;

FIG. 11A is a perspective view showing holding plates of a curtain hanger according to a fourth embodiment of the present invention;

FIG. 11B is a perspective view showing a state obtained immediately before a clip portion with a hook portion is fitted on the holding plates shown in FIG. 11A;

FIG. 12A is a perspective view showing holding plates with a hook portion of a curtain hanger according to a fifth embodiment of the present invention;

FIG. 12B is a perspective view showing a state obtained immediately before a clip portion is fitted on the holding plates shown in FIG. 12A;

FIG. 13A is a perspective view showing holding plates of a curtain hanger according to a sixth embodiment of the present invention;

FIG. 13B is a perspective view showing a state obtained immediately before a clip portion with a hook portion is fitted on the holding plates shown in FIG. 13A;

FIG. 14 is a perspective view of a curtain hanger according to a seventh embodiment of the present invention;

FIG. 15 is a sectional view of a clip portion taken along line F15-F15 of FIG. 14;

FIGS. 16A, 16B and 16C are perspective views individually showing steps of procedure for attaching the curtain hanger shown in FIG. 14 to a curtain;

FIGS. 16D and 16E are perspective views individually showing steps of procedure for removing the curtain hanger shown in FIG. 14 from the curtain;

FIG. 17A is a perspective view of a curtain hanger according to an eighth embodiment of the present invention;

FIG. 17B is a perspective view showing a state in which a holding portion of the curtain hanger shown in FIG. 17A is closed;

FIG. 18 is a perspective view showing a hook portion of a curtain hanger according to a ninth embodiment of the present invention and a part of a curtain rail;

FIG. 19 is a perspective view showing a curtain hanger according to a tenth embodiment of the present invention;

FIG. 20 is a perspective view showing a curtain hanger according to an eleventh embodiment of the present invention;

FIGS. 21A, 21B and 21C are perspective views individually showing steps of procedure for attach-

ing the curtain hanger shown in FIG. 20 to a curtain;

FIGS. 21D and 21E are perspective views individually showing steps of procedure for removing the curtain hanger shown in FIG. 20 from the curtain;

FIG. 22 is a perspective view showing a conventional curtain hanger;

FIG. 23A is a side view showing another conventional curtain hanger; and

FIG. 23B is a perspective view of the curtain hanger shown in FIG. 23A.

Best Mode for Carrying Out the Invention

[0017] Embodiments of the present invention will now be described with reference to the drawings. FIGS. 1 to 4 show a curtain hanger 10 according to a first embodiment of the present invention. In these drawings, numeral 20 denotes a curtain. The curtain hanger 10 comprises a pair of openable holding plates 1 and 2 that function as holding portions for holding a pleat portion 21 of the curtain 20, a hook portion 3 formed on the one holding plate 1, and a clip portion 4.

[0018] As shown in FIGS. 2 and 3, the holding plates 1 and 2 have a function to clamp the pleat portion 21 of the curtain 20 from both sides in the thickness direction thereof. These holding plates 1 and 2 may be separated from each other. As shown in FIG. 1, the holding plates 1 and 2 should preferably be coupled to each other by means of a hinge 7 so that they are easy to handle and can be prevented from being lost.

[0019] In a preferred form, opposite surfaces 1a and 2a of the holding plates 1 and 2 are provided with protrusions 5 and recesses 6 that serve to prevent the curtain 20 from slipping down when the pleat portion 21 of the curtain 20 is clamped. The protrusions 5 and the recesses 6 are situated in corresponding positions such that the protrusions 5 get individually into the recesses 6 when the opposite surfaces 1a and 2a are joined. The recesses 6 may be bottomed recesses or holes that penetrate the holding plates 1 and 2.

[0020] The holding plates 1 and 2 and the clip portion 4 are provided with a retaining mechanism for preventing the clip portion 4 from slipping off. As shown in FIGS. 2 and 3, the retaining mechanism includes guide grooves 14 formed laterally extending on the respective outer surfaces of the holding plates 1 and 2, vertical lock grooves 15 formed individually at the respective terminal ends of the guide grooves 14 so as to communicate with the guide grooves 14, and lock projections 4a formed on the inner surface of the clip portion 4. When the clip portion 4 is fitted on the holding plates 1 and 2, the lock projections 4a of the clip portion 4 are slid along the guide grooves 14 toward the lock grooves 15. Thereafter, they are lowered along the lock grooves 15 at the respective terminal ends of the guide grooves 14, whereupon the clip portion 4 is locked to the holding plates 1 and 2. This retaining mechanism can securely

keep the holding plates 1 and 2 closed or maintain the clamped state of the pleat portion 21 of the curtain 20.

[0021] The clip portion 4 has a U-shaped cross section. More specifically, the clip portion 4 has a pair of arms 4a and 4b, left and right, and a portion 4c that connects the respective one-end portions of the arms 4a and 4b. The clip portion 4 prevents the holding plates 1 and 2 from opening by externally pressing the holding plates 1 and 2 in a manner such that it is fitted on the holding plates 1 and 2 that clamp the pleat portion 21 of the curtain 20, as shown in FIG. 4. Although the clip portion 4 may be separated from the holding plates 1 and 2, it should preferably be coupled to the holding plates 1 and 2 by means of a pair of straps 8, as in the illustrated example. The straps 8 can prevent the clip portion 4 from being lost. The straps 8 may be belt-shaped.

[0022] The hook portion 3 is hung on a runner 51 (shown in FIG. 2) that slides along a curtain rail 50. By this hanging (connection), the curtain hanger 10 can be suspended from the curtain rail 50. Instead of using the curtain rail 50 that is provided with the runner 51, a hook receiving member may be provided on a curtain attachment portion of a window or the like so that the curtain hanger 10 can be fixed directly to the curtain attachment portion by hanging the hook portion 3 on the hook receiving member. The holding plates 1 and 2, hook portion 3, clip portion 4, and straps 8 are molded integrally from a synthetic resin (e.g., polyacetal, nylon, polypropylene, hard polyvinyl chloride, etc.). Anti-skid ridges 9 are formed on the outer surface of the clip portion 4 lest fingers slip thereon as they manipulate the clip portion 4.

[0023] The following is a description of the way of using the curtain hanger 10 according to the first embodiment (FIGS. 1 to 4). First, the pleat portion 21 is formed by folding the upper part of the curtain 20, as shown in FIG. 1. The formation of the pleat portion 21 in the curtain 20 can make the curtain 20 look deluxe.

[0024] Then, the pleat portion 21 is clamped from both sides in the thickness direction by means of the holding plates 1 and 2, as shown in FIG. 2. Thereafter, the lock projections 4a are inserted into the guide grooves 14 in the direction of arrow F1 in FIG. 3. Then, the arms 4a and 4b of the clip portion 4 are fitted on the outside of the holding plates 1 and 2, as shown in FIG. 4. As this is done, the holding plates 1 and 2 are pressed from the outside by means of the spring properties of the clip portion 4, so that the pleat portion 21 of the curtain 20 can be clamped tight. Since the protrusions 5 on the opposite surfaces 1a and 2a of the holding plates 1 and 2 press down the pleat portion 21 toward the recesses 6, moreover, the curtain 20 never slips off the curtain hanger 10. By hanging the hook portion 3 on the runner 51, the curtain 20 can be suspended from the rail 50 by means of the curtain hanger 10.

[0025] FIG. 5 shows another example of use of the curtain hanger 10. In this example of use, a plurality of

types of curtain materials 20a and 20b that are different in color and/or stuff and independent of one another are alternately coupled by means of the curtain hangers 10. By doing this, the curtain 20 of a desired design can be obtained without sewing a plurality of types of curtain materials 20a and 20b to one another. In the case of this example of use, the curtain materials 20a and 20b can be easily separated by removing the curtain hangers 10 from the curtain materials 20a and 20b. Accordingly, the curtain materials 20a and 20b can be washed and replaced with ease.

[0026] FIGS. 6 to 9 show a curtain hanger 10 according to a second embodiment of the present invention. This curtain hanger 10 is formed integrally on a clip portion 4 without providing a hook portion 3 on a holding plate 1. By doing this, the height of projection of the hook portion 3 can be reduced to lessen the volume of a package of curtain hangers 10. Since the basic configuration and functions and effects of the curtain hanger 10 of this second embodiment (FIGS. 6 to 9) are the same as those of the first embodiment (FIGS. 1 to 4), common numerals are used to designate to portions that are common to the two embodiments, and a description of those portions is omitted.

[0027] FIGS. 10A and 10B show a curtain hanger 10 according to a third embodiment of the present invention. The same numerals are used to designate the same elements of the first embodiment, and a detailed description of those elements is omitted. A clip portion 11 of the curtain hanger 10 of this third embodiment has a shape such that it can be fitted onto holding plates 1 and 2 from above. More specifically, this clip portion 11 includes a pair of arms 11a and 11b, left and right, and an upper wall 11c that connects the respective upper ends of the arms 11a and 11b. Projections 11d and 11e are formed on the opposed surfaces of the arms 11a and 11b, respectively. The respective outer surfaces of the holding plates 1 and 2 are formed having recesses 1b (only one of which is shown 10B) in which the projections 11d and 11e can be fitted individually. If the clip portion 11 is fitted onto the holding plates 1 and 2 from above after the holding plates 1 and 2 clamp a pleat portion of a curtain, the projections 11d and 11e are fitted in the recesses 1b, individually. Thus, the holding plates 1 and 2 can be prevented from slipping from the clip portion 11. A hook portion 3 is formed integrally with the holding plate 1.

[0028] FIGS. 11A and 11B show a curtain hanger 10 according to a fourth embodiment of the present invention. In this curtain hanger 10, a hook portion 3 is formed integrally on an upper wall 11c of a clip portion 11 with an inverted-U-shaped cross section. For other configurations, functions, and effects, this embodiment is similar to the third embodiment (FIGS. 10A and 10B). Therefore, common numerals are used to designate to portions that are common to the two embodiments, and a description of those portions is omitted. In the third and fourth embodiments, as in the first embodiment, the

holding plates 1 and 2 and the clip portion 11 may be also coupled by means of flexible straps.

[0029] FIGS. 12A and 12B show a curtain hanger 10 according to a fifth embodiment of the present invention. A clip portion 12 of this embodiment is in the form of a square frame. More specifically, this clip portion 12 is provided with a pair of arms 12a and 12b, left and right, an upper wall 12c that connects the respective upper ends of these arms 12a and 12b, a lower wall 12d that connects the respective lower ends of the arms 12a and 12b, and catch portions 12e on the arms 12a and 12b. The respective outer surfaces of holding plates 1 and 2 are formed having grooves 25 in which the catch portions 12e can be fitted individually. Notches 1c and 2c for engagement with the lower wall 12d of the clip portion 12 are formed at the lower ends of the holding plates 1 and 2, respectively. If the lower wall 12d of the clip portion 12 is inserted into the notches 1c and 2c of the holding plates 1 and 2, the clip portion 12 can rock in the direction of arrow F2 (shown in FIG. 12B) around the lower wall 12d. As the clip portion 12 rocks in this manner, the catch portions 12e are fitted individually in the grooves 25, whereby the holding plates 1 and 2 are prevented from opening. Since the basic configuration and functions and effects of this fifth embodiment are the same as those of the third embodiment (FIGS. 10A and 10B), common numerals are used to designate to portions that are common to the two embodiments, and a description of those portions is omitted.

[0030] FIGS. 13A and 13B show a curtain hanger 10 according to a sixth embodiment of the present invention. In this curtain hanger 10, a hook portion 3 is formed integrally on an upper wall 12c of a frame-shaped clip portion 12. For other configurations, functions, and effects, this embodiment is similar to the fifth embodiment (FIGS. 12A and 12B). In the fifth and sixth embodiments also, holding plates 1 and 2 and the clip portion 12 may be also coupled by means of flexible straps.

[0031] FIG. 14 shows a curtain hanger 10 according to a seventh embodiment of the present invention. The curtain hanger 10 of this embodiment is provided with a holding portion 61 with a U-shaped cross section and a frame-shaped clip portion 62. The clip portion 62 includes an upper wall 64, a pair of side walls 65, left and right, and a bottom wall 66, which are molded integrally with one another. A hook portion 67 is formed integrally on the upper wall 64. The holding portion 61 is coupled to the bottom wall 66 by means of flexible straps 68. The clip portion 62, hook portion 67, holding portion 61, and straps 68 are molded integrally with one another from a synthetic resin. The holding portion 61 includes a proximal portion 69 that serves as a hinge and arms 71 that each extend across a taper portion 70 from the proximal portion 69. Projections 72 are formed individually on the opposed portions of the respective distal ends of the arms 71.

[0032] A holding portion fitting hole 73, which is sur-

rounded by the upper wall 64, side walls 65, and bottom wall 66, is formed in the central position of the clip portion 62. A holding portion removal opening 74 is formed in that part of the holding portion fitting hole 73 which is situated on the side of the hook portion 67. The removal opening 74 has a size such that the holding portion 61 inserted in the holding portion fitting hole 73 can be drawn out of it when the holding portion 61 is slid toward the hook portion 67. A strap storage recess 75 for the insertion of the straps 68 is formed in that part of the holding portion fitting hole 73 which is situated on the side of the straps 68. The holding portion fitting hole 73, removal opening 74, and strap storage recess 75 communicate with one another.

[0033] A retaining mechanism 76 for preventing the clip portion 62 from slipping off is provided between the holding portion 61 and the clip portion 62. This retaining mechanism 76 is composed of a plurality of self-locking detents 77 formed on the respective outer surfaces of the taper portions 70 of the holding portion 61 and edges 79 of taper surfaces 78 that are formed individually on the respective inner surfaces of the side walls 65. The taper surfaces 78 are inclined so that a width W1 of the holding portion fitting hole 73 is gradually reduced in the direction (indicated by arrow F3 in FIG. 15) of insertion of the holding portion 61.

[0034] The inner surfaces of the holding portion removal opening 74 constitute taper surfaces 80 of which an opening width W2 is gradually reduced in the direction (opposite to the direction indicated by arrow F3 in FIG. 15) of removal of the holding portion 61. With use of these taper surfaces 80, the holding portion 61 can be smoothly drawn out of the removal opening 74.

[0035] The usage of the curtain hanger 10 shown in FIG. 14 will now be described with reference to FIGS. 16A to 16E.

(1) The pleat portion 21 is formed in a position for the attachment of the holding portion 61 of the curtain hanger 10 (shown in FIG. 16A) by folding the top portion of the curtain 20.

(2) The pleat portion 21 of the curtain 20 is laterally inserted into the space between the pair of arms 71 of the holding portion 61.

(3) As shown in FIG. 16B, the proximal portion 69 of the holding portion 61, holding the pleat portion 21 of the curtain 20 therein, is inserted into the holding portion fitting hole 73 of the clip portion 62.

(4) As shown in FIG. 16C, the straps 68 are inserted into the strap storage recess 75 of the clip portion 62 as the holding portion 61 is further inserted into the clip portion 62. As this is done, the taper portions 70 of the holding portion 61 abut against and are pressed by the taper surfaces 78 of the clip portion 62, so that the arms 71 of the holding portion 61 are elastically deformed in their closing direction. Thus, the pleat portion 21 of the curtain 20 is firmly clamped by means of the arms

71. At the same time, the self-locking detents 77 get beyond the edges 79 of the taper surfaces 78, thereby causing the edges 79 to engage the self-locking detents 77, so that the holding portion 61 is prevented from slipping from the clip portion 62. Since the clip portion 62 of this embodiment is in the form of a frame such that the holding portion fitting hole 73 cannot easily spread, so that the holding portion 61 that clamps the pleat portion 21 of the curtain 20 can be held firmly.

(5) The hook portion 67 of the curtain hanger 10 thus attached to the curtain 20 is connected to the runner 51 of the curtain rail 50 (shown in FIG. 16A).

[0036] In order to remove the curtain 20 that is suspended from the runner 51, the holding portion 61 is slid from the holding portion fitting hole 73 toward the hook portion 67 so that the holding portion 61 is situated in the removal opening 74, as shown in FIG. 16D. Subsequently, the holding portion 61 is drawn out of the removal opening 74, as shown in FIG. 16E. The pleat portion 21 of the curtain 20 is removed from the arms 71 of the holding portion 61 that is thus drawn out to be free.

[0037] FIGS. 17A and 17B show a curtain hanger 10 according to an eighth embodiment of the present invention. In this curtain hanger 10, a holding portion 61 with a U-shaped cross section is provided with a hinge 81 and a retaining mechanism 76. For other configurations, this embodiment is similar to the seventh embodiment (FIG. 14). A proximal portion 69 of the holding portion 61 of this eighth embodiment has the hinge 81 in the form of a notch. A pair of arms 71 each extend across a taper portion 70 from the proximal portion 69. Protrusions 5 are formed on one of opposed faces 82 of the paired arms 71 of the holding portion 61, and holes 6a are formed in the other. The holes 6a are formed in positions corresponding to the protrusions 5. A curtain is prevented from slipping off as the protrusions 5 get individually into the holes 6a with a pleat portion of the curtain clamped by means of the holding portion 61. Thus, the protrusions 5 and the holes 6a constitute the retaining mechanism 76.

[0038] FIG. 18 shows a curtain hanger 10 according to a ninth embodiment of the present invention. In this curtain hanger 10, a hook portion 67 is shaped so that the curtain hanger 10 can be easily hung on a runner 51 of a curtain rail 50 and enjoys a merit of moldability. The hook portion 67 shown in FIG. 18 has an extension portion 85 that extends integrally from the central position of an upper wall 64 of a frame-shaped clip portion 62 in the longitudinal direction of the clip portion 62. The extension portion 85 extends parallel to the longitudinal direction of the clip portion 62 across a slanting portion 84 that is offset in the thickness direction of the clip portion 62. An L-shaped hook distal end portion 83, which protrudes from a side face of the extension portion 85 in the thickness direction of the clip

portion 62, is molded so that its distal end face A is flush with a surface 62a of the clip portion 62.

[0039] In the hook portion 67 having this shape, the hook distal end portion 83 is directed at right angles to the curtain rail 50, so that the hook portion 67 can be easily hung on the runner 51.

[0040] If the hook distal end portion 83 is formed on a surface B of the extension portion 85, the construction of a mold for molding the hook portion 67 is complicated. This is because the mold for molding the hook portion with the aforesaid shape must use a slide mold, besides upper and lower molds. Since the respective positions of a surface A of the hook distal end portion 83 and the surface B of the extension portion 85 in the hook portion 67 of the aforesaid embodiment (FIG. 18) are deviated from each other in the width direction of the clip portion 62, on the other hand, the hook portion can be molded by means of upper and lower molds only, so that the construction of the mold can be simple. Accordingly, the manufacture of the mold is easy, and the molding cost can be lowered.

[0041] FIG. 19 shows a curtain hanger 10 according to a tenth embodiment of the present invention. Although the curtain hanger 10 of this embodiment is constructed substantially in the same manner as the seventh embodiment (FIG. 14), it differs from the seventh embodiment in the relative positions of the holding portion fitting hole 73 and the removal opening 74 and in the position of the hook portion 67.

[0042] More specifically, a hook portion 67 of the tenth embodiment (FIG. 19) is formed on a proximal portion 69 of a holding portion 61. When the holding portion 61 is overturned and laterally inserted into the holding portion fitting hole 73, as indicated by two-dot chain line in FIG. 19, the hook portion 67 can be hung on a runner of a curtain rail as it faces downward. A clip portion 62 is formed having, from top to bottom, a holding portion fitting hole 73, a removal opening 74, and a strap storage recess 75, which communicate with one another. According to this embodiment, the holding portion 61 having the hook portion 67 can be attached to the holding portion fitting hole 73 that is formed in the upper part of the clip portion 62, so that the gap between the curtain rail and a curtain can be lessened.

[0043] FIG. 20 shows a curtain hanger 10 according to an eleventh embodiment of the present invention. The curtain hanger 10 of this embodiment is provided with a holding portion 61 for clamping a pleat portion 21 of a curtain 20 from above, as shown in FIG. 21C. A hook portion 67 of this embodiment is formed on a proximal portion 69 of a holding portion 61. When the pleat portion 21 of the curtain 20 is clamped by means of the holding portion 61 from above, as shown in FIG. 21C, the hook portion 67 can be hung on a runner of a curtain rail as it faces upward.

[0044] The usage of the curtain hanger 10 of this eleventh embodiment will now be described with reference to FIGS. 21A to 21E.

(1) The pleat portion 21 is formed in a position for the attachment of the holding portion 61 of the curtain hanger 10 (shown in FIG. 21A) by folding the top portion of the curtain 20.

(2) The curtain hanger 10 is opposed to the upper edge of the pleat portion 21 of the curtain 20.

(3) As shown in FIG. 21B, a clip portion 62 is kept horizontal and arms 71 are opened. The proximal portion 69 of the holding portion 61 is inserted into a holding portion fitting hole 73 of the clip portion 62. The pleat portion 21 of the curtain 20 is interposed between the pair of open arms 71.

(4) As shown in FIG. 21C, straps 68 are inserted into a strap storage recess 75 as the holding portion 61 is further inserted into the holding portion fitting hole 73. As this is done, taper portions 70 of the holding portion 61 abut against and are pressed by taper surfaces 78 of the clip portion 62, so that the arms 71 of the holding portion 61 are elastically deformed in their closing direction. Thus, the pleat portion 21 of the curtain 20 is firmly clamped by means of the arms 71. At the same time, self-locking detents 77 get beyond edges 79 of the taper surfaces 78, thereby causing the edges 79 to engage the self-locking detents 77, so that the holding portion 61 is prevented from slipping from the clip portion 62.

(5) The hook portion 67 of the curtain hanger 10 thus attached to the curtain 20 is hung on the runner of the curtain rail.

[0045] In order to remove the curtain 20 that is suspended from the runner, the holding portion 61 is slid from the holding portion fitting hole 73 to the position of a removal opening 74 as shown in FIG. 21D. Subsequently, the holding portion 61 is drawn out of the removal opening 74, as shown in FIG. 21E. The pleat portion 21 of the curtain 20 is removed from the arms 71 of the holding portion 61 that is thus drawn out to be free. Since the curtain hanger 10 of this embodiment is constructed so that the pleat portion 21 of the curtain 20 is held from above, it enjoys art effect such that the curtain can be easily removed from the curtain rail by its own weight, as well as the functions and effects described in connection with the seventh embodiment (FIG. 14).

Industrial Applicability

[0046] As seen from the above description, the curtain hanger of the present invention has the following effects.

(1) Since the curtain is suspended with its pleat portion clamped, it can avoid suffering formation of wrinkles or damage that may be caused when the curtain is hooked from below as in the cases of the conventional curtain hangers.

(2) The curtain hanger of the present invention unites a function to hold the pleat portion, which is formed by folding the curtain, laterally or from above and a function to suspend the curtain, so that it can obviate the necessity of a tape or sewing operation for forming pleat portions, which has conventionally been a problem. Since the pleat portion of the curtain can be eliminated by removing the curtain hanger of the present invention from the pleat portion, the curtain can be washed with ease. By coupling a plurality of types of curtain materials by means of the curtain hangers of the present invention, a curtain of a design that agrees with a user's taste can be made without requiring sewing operation.

(3) The curtain hanger of the present invention is constructed so that it can suspend the curtain by laterally holding the pleat portion of the curtain. Thus, the gap between the curtain rail and the curtain can be eliminated to improve the appearance of the curtain as an interior decoration.

(4) The curtain hanger of the present invention can hold ornamental cloth, if necessary, as it holds the pleat portion of the curtain laterally or from above, so that the ornamental function as the interior decoration can be improved further.

(5) In the curtain hanger of the present invention, the clip portion has a U-shaped cross section, including a pair of arms, and is designed to hold the holding plates, clamping the pleat portion of the curtain, from both sides. As the arms of the clip portion display their spring properties, therefore, a proper clamping force can be exerted despite the change of the thickness of the material. Thus, the change of the thickness of the material can be coped with.

(6) In the curtain hanger of the present invention, the holding portion is provided with a pair of holding plates that hold the pleat portion of the curtain from both sides, and the mating protrusions and recesses are formed on or in the respective opposed surfaces of the holding plates. When the holding plates are closed, therefore, the protrusions press down the pleat portion toward the recesses, so that the curtain can be prevented from slipping off.

(7) In the curtain hanger of the present invention, the retaining mechanism for preventing the holding portion from the clip portion is provided between the clip portion and the holding portion, so that the pleat portion of the curtain can be securely clamped by means of the holding plates.

(8) In the curtain hanger of the present invention, the clip portion is in the form of a frame that cannot be easily deformed and the holding portion is inserted into the frame shaped clip portion. Thus, the holding portion clamping the pleat portion of the curtain can be restricted tight by means of the

frame-shaped clip portion, so that the state of the pleat portion of the curtain clamped by means of the holding plates can be stabilized.

(9) In the curtain hanger of the present invention, the holding portion and the clip portion are connected by means of the straps, so that these portions can be prevented from being lost. If the holding portion, clip portion, hook portion, and straps are molded integrally from a synthetic resin, moreover, parts control is facilitated, and the attachment of the clip portion to the holding portion is easy.

Claims

1. A curtain hanger characterized by comprising clamping means for clamping a folded pleat portion of a curtain, the curtain being suspended in a manner such that said pleat portion is clamped by means of the clamping means.
2. A curtain hanger characterized by comprising clamping means for clamping a folded pleat portion of a curtain laterally or from above, the curtain being suspended in a manner such that said pleat portion is clamped by means of the clamping means.
3. A curtain hanger characterized by comprising clamping means for clamping a folded pleat portion of a curtain laterally or from above, a clip portion for keeping said pleat portion clamped by means of the holding portion, and a hook portion connected directly or indirectly to a curtain rail.
4. A curtain hanger according to claim 3, characterized in that said holding portion is provided with a pair of holding plates for holding said pleat portion of the curtain from both sides in the thickness direction thereof, and protrusions and recesses capable of mating with one another are formed on or in the respective opposed surfaces of the holding plates.
5. A curtain hanger according to claim 3, characterized in that said holding portion and said clip portion are coupled to each other by means of flexible straps.
6. A curtain hanger according to claim 4, characterized in that said holding portion and said clip portion are coupled to each other by means of flexible straps.
7. A curtain hanger according to claim 5, characterized in that said holding portion, hook portion, clip portion, and straps are molded integrally with one another from a synthetic resin.

8. A curtain hanger according to claim 6, characterized in that said holding portion, hook portion, clip portion, and straps are molded integrally with one another from a synthetic resin. 5
9. A curtain hanger according to claim 3, characterized in that a retaining mechanism for preventing the clip portion from being disengaged from said holding portion is provided between the holding portion and the clip portion. 10
10. A curtain hanger according to claim 4, characterized in that a retaining mechanism for preventing the clip portion from being disengaged from said holding portion is provided between the holding portion and the clip portion. 15
11. A curtain hanger according to claim 5, characterized in that a retaining mechanism for preventing the clip portion from being disengaged from said holding portion is provided between the holding portion and the clip portion. 20
12. A curtain hanger according to claim 6, characterized in that a retaining mechanism for preventing the clip portion from being disengaged from said holding portion is provided between the holding portion and the clip portion. 25
13. A curtain hanger according to claim 7, characterized in that a retaining mechanism for preventing the clip portion from being disengaged from said holding portion is provided between the holding portion and the clip portion. 30
14. A curtain hanger according to claim 8, characterized in that a retaining mechanism for preventing the clip portion from being disengaged from said holding portion is provided between the holding portion and the clip portion. 35 40
15. A curtain hanger according to any one of claims 3 to 14, characterized in that said clip portion includes a pair of arms having spring properties and capable of externally holding said holding portion, thereby maintaining the holding state of said holding portion. 45
16. A curtain hanger according to any one of claims 3 to 14, characterized in that said clip portion is in the form of a frame having a holding portion fitting hole, and said frame-shaped clip portion and said holding portion are joined in a manner such that the holding portion is inserted into said holding portion fitting hole of the clip portion. 50 55

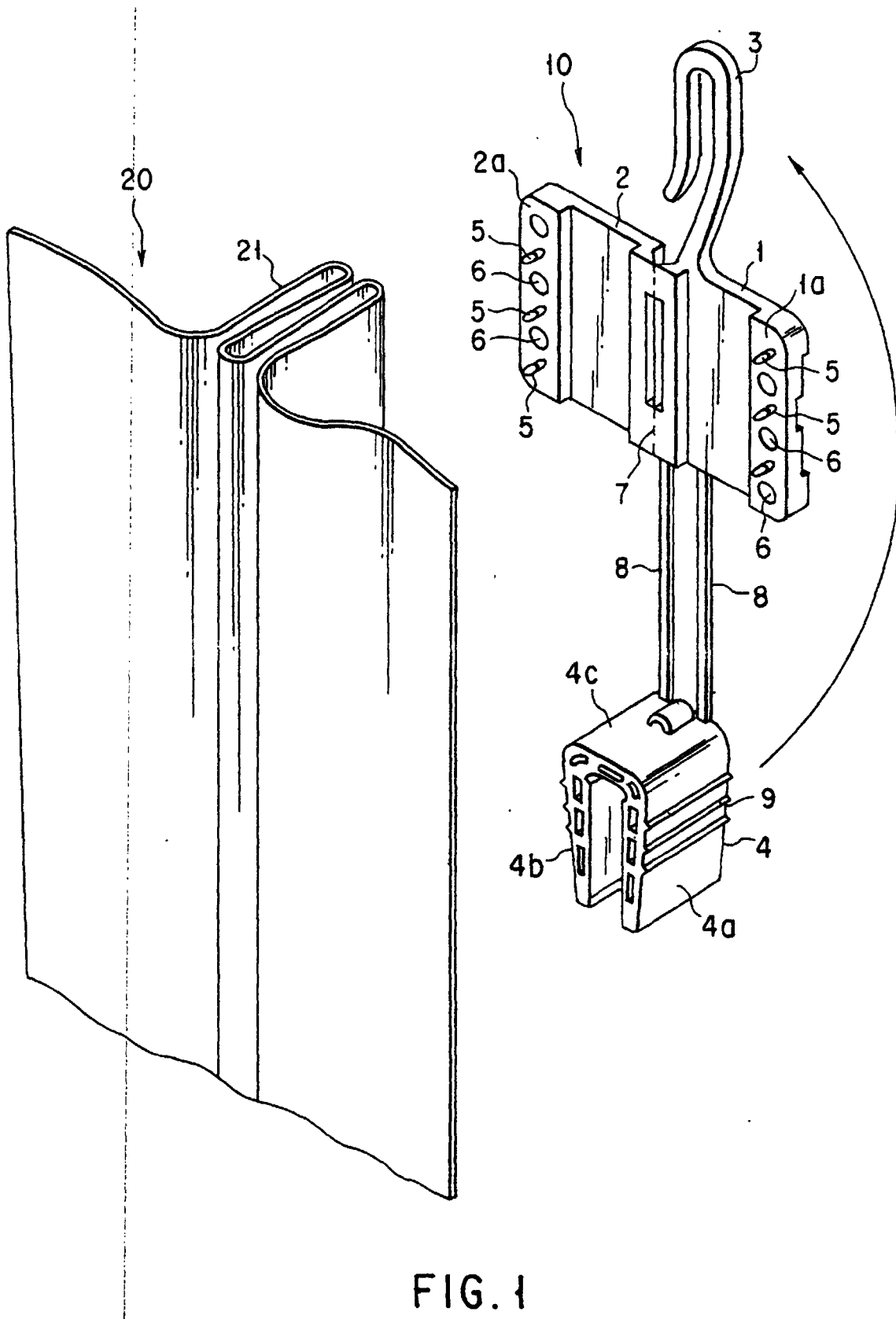

FIG. 1

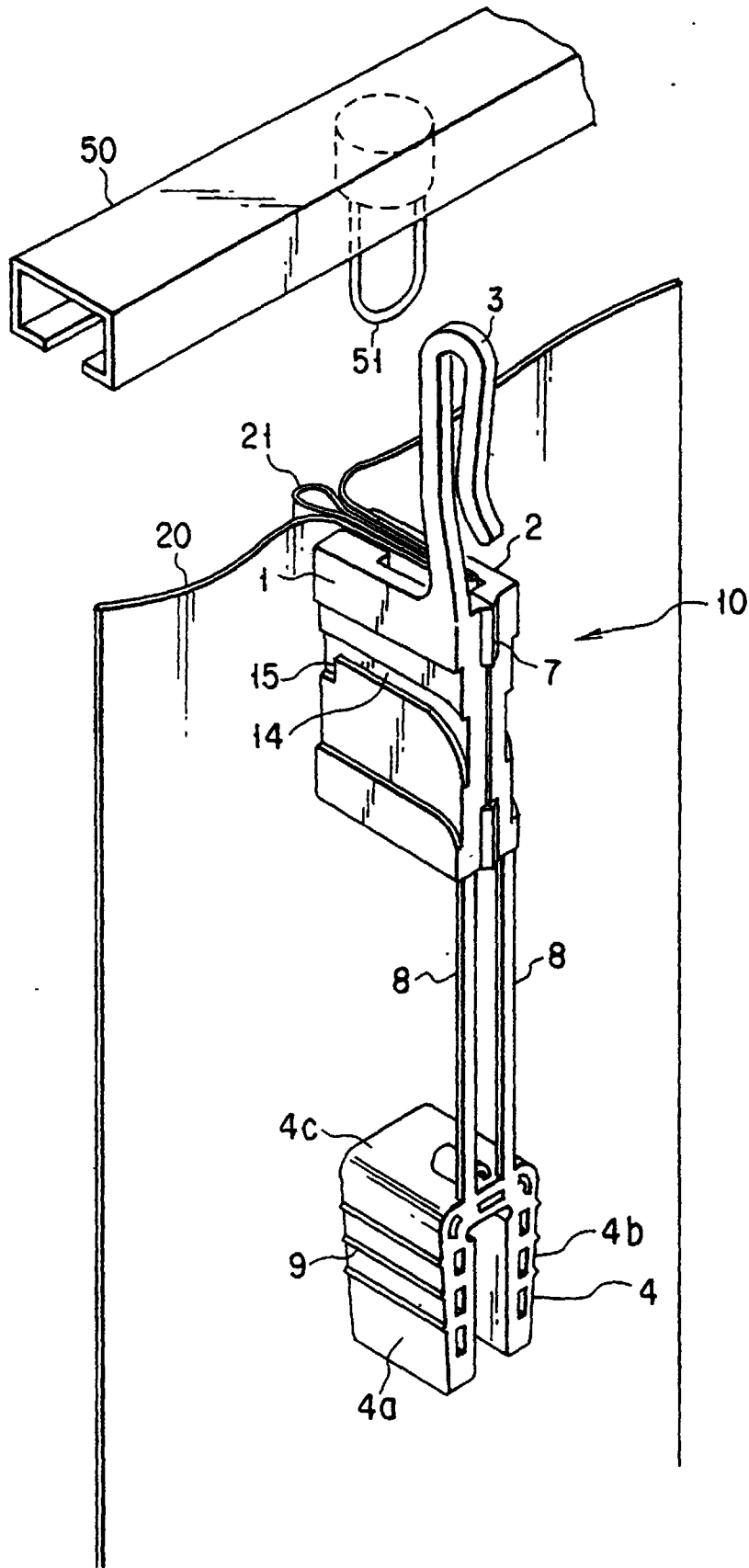

FIG. 2

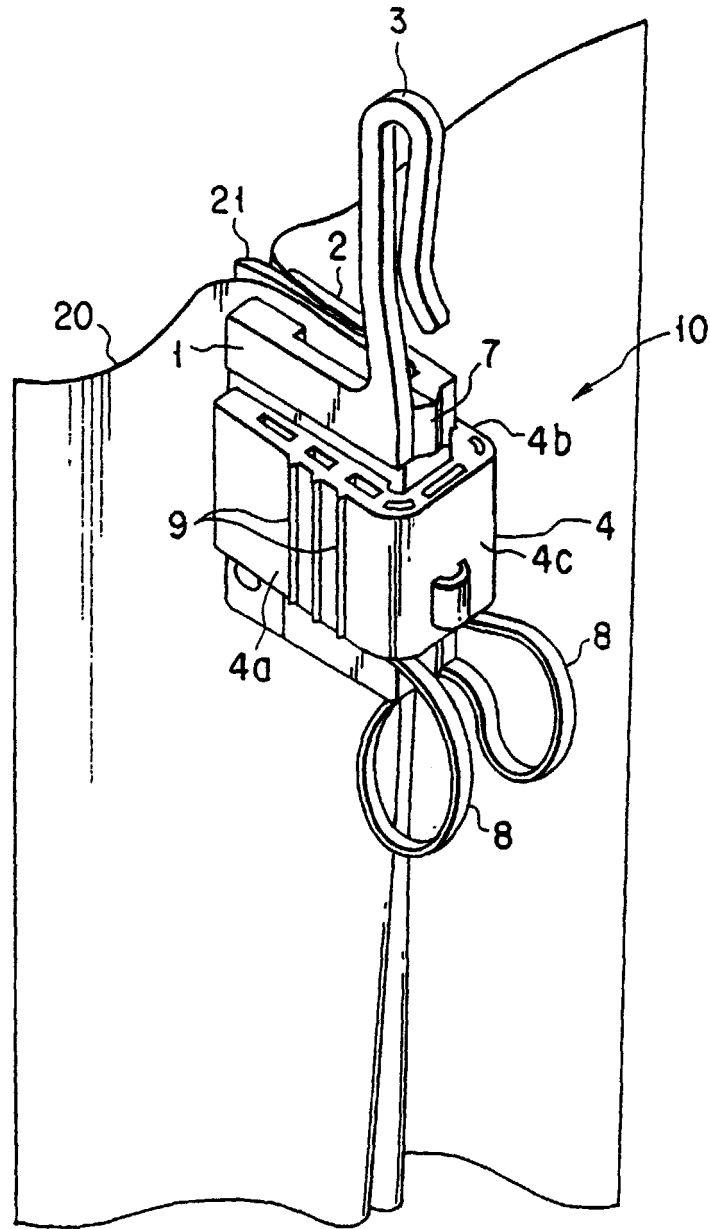

FIG. 4

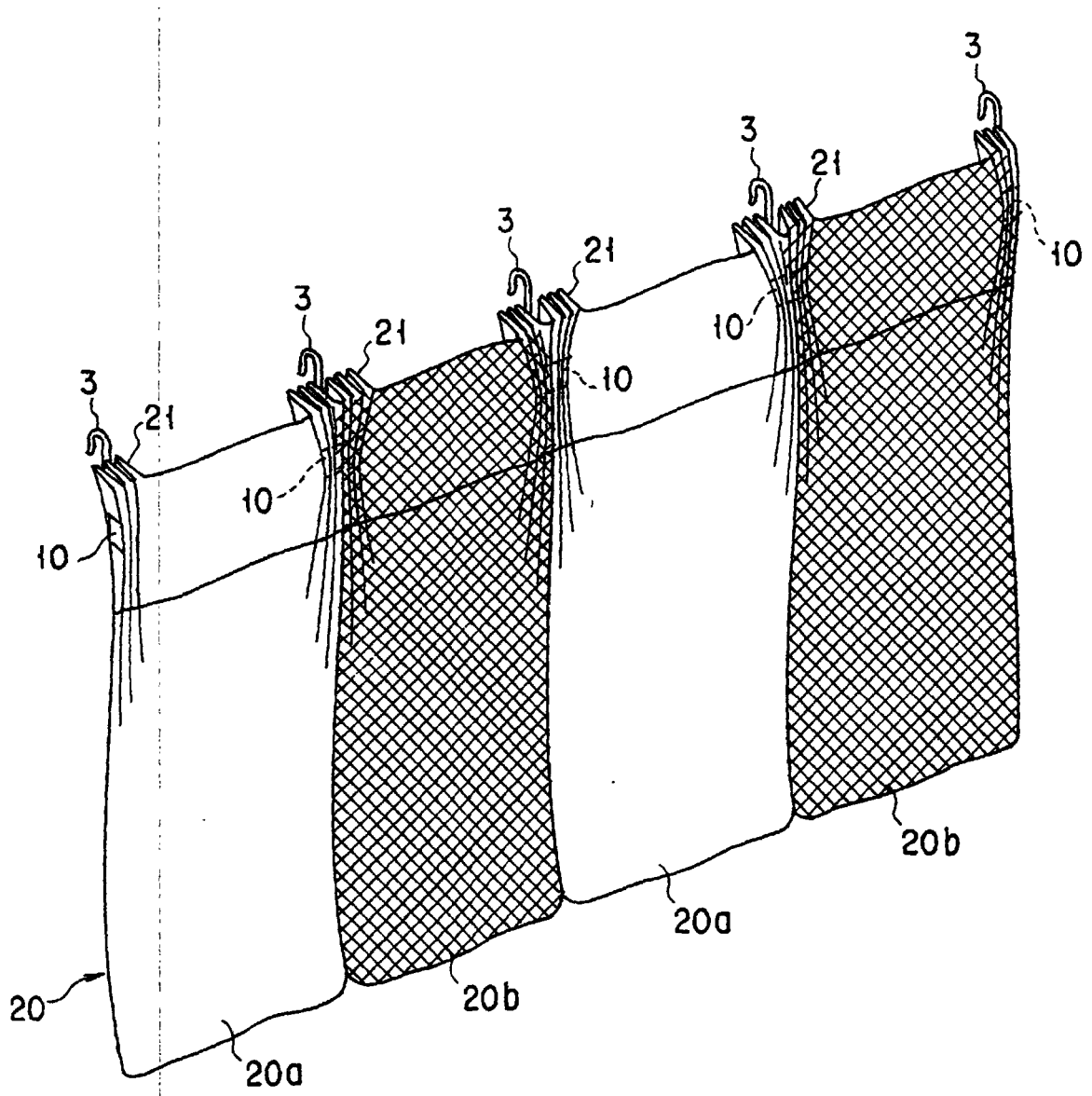

FIG. 5

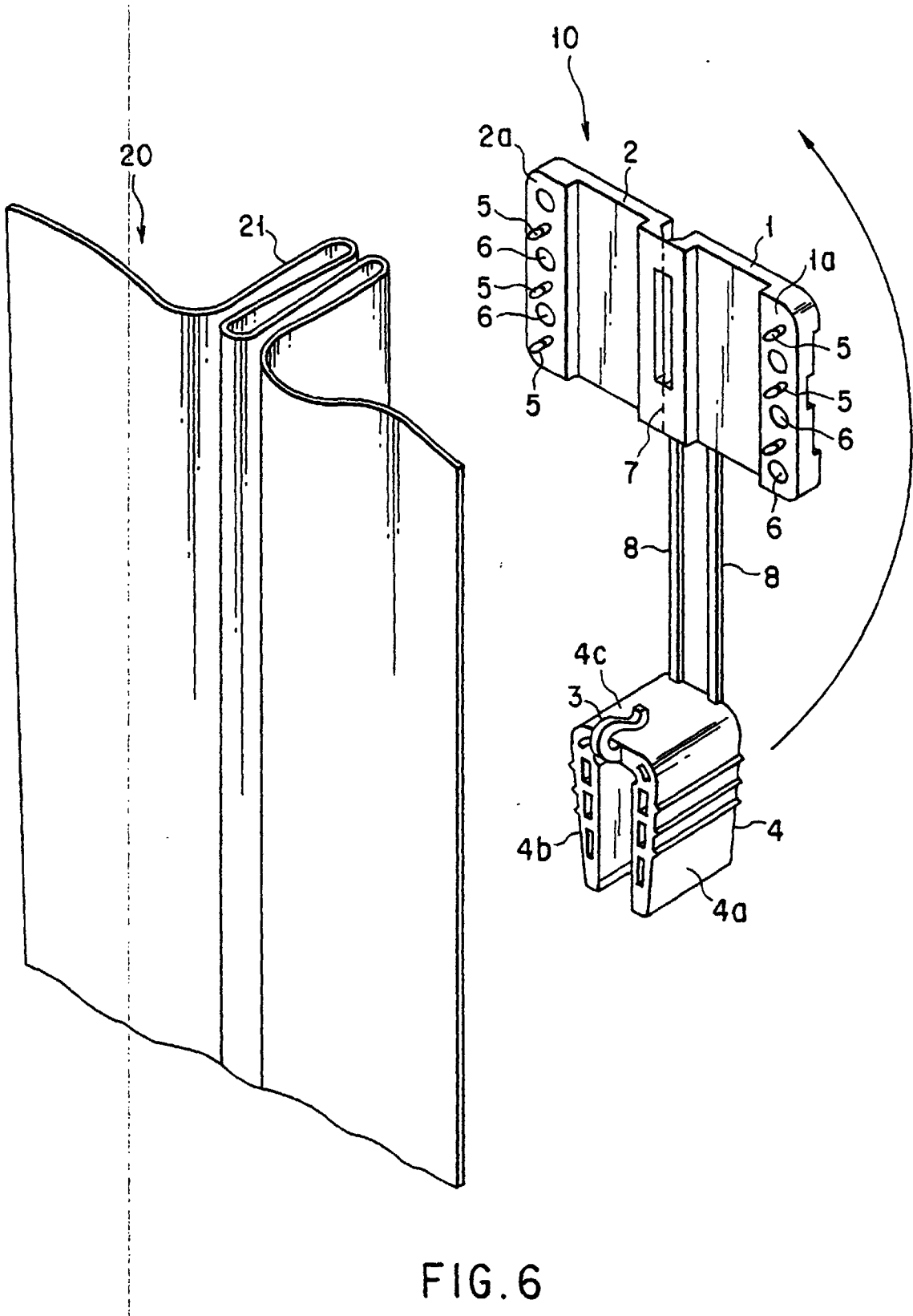
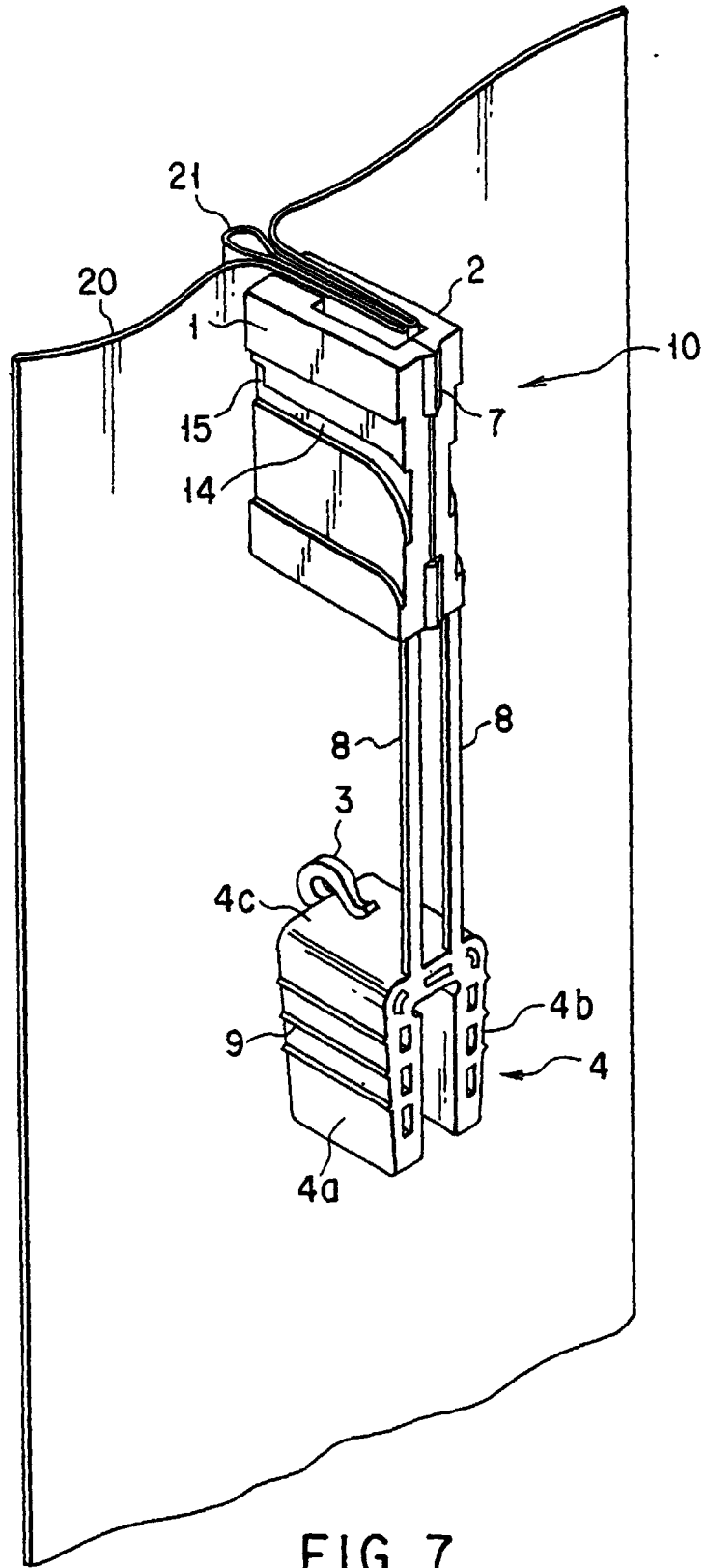

FIG. 6



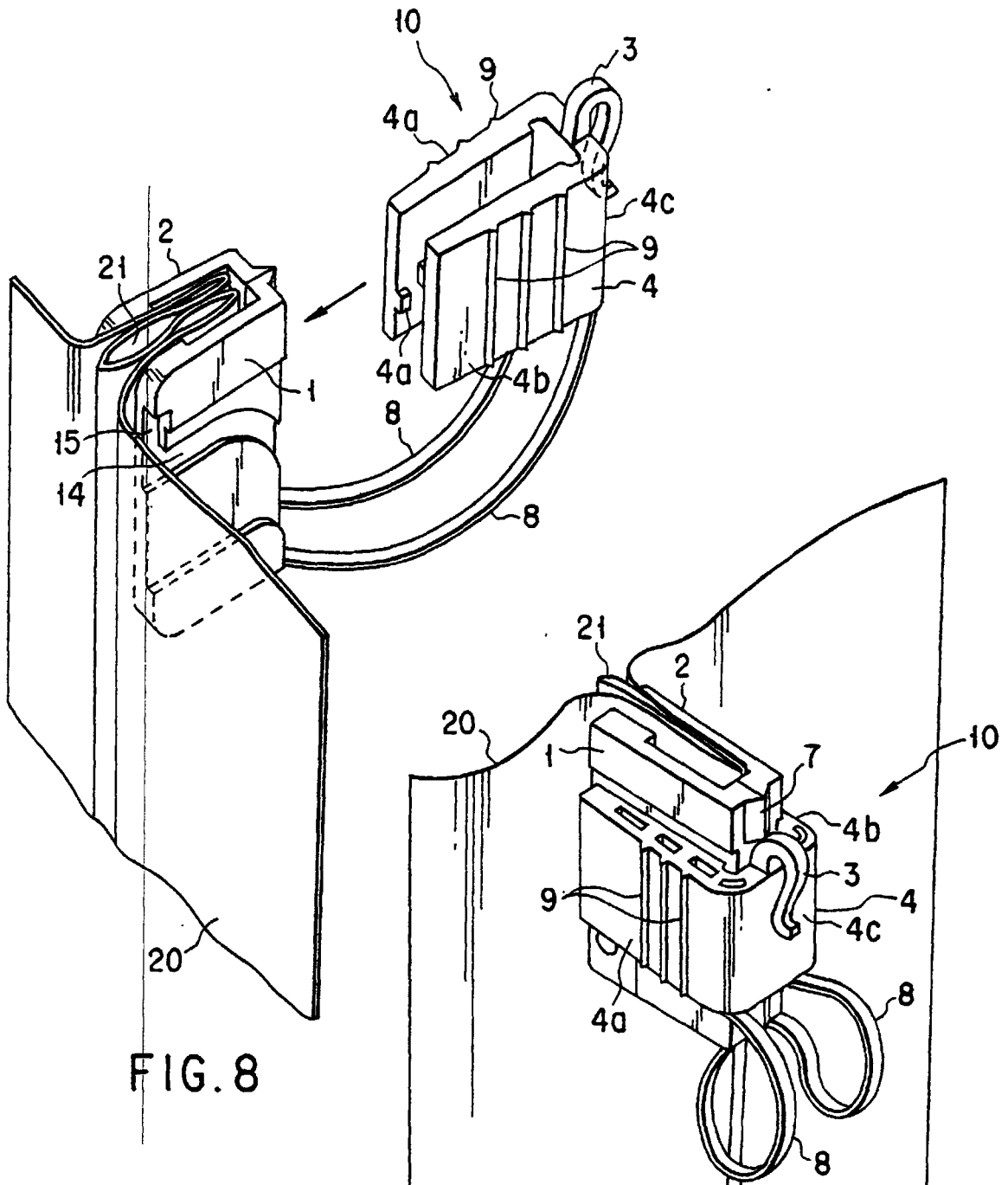

FIG. 8

FIG. 9

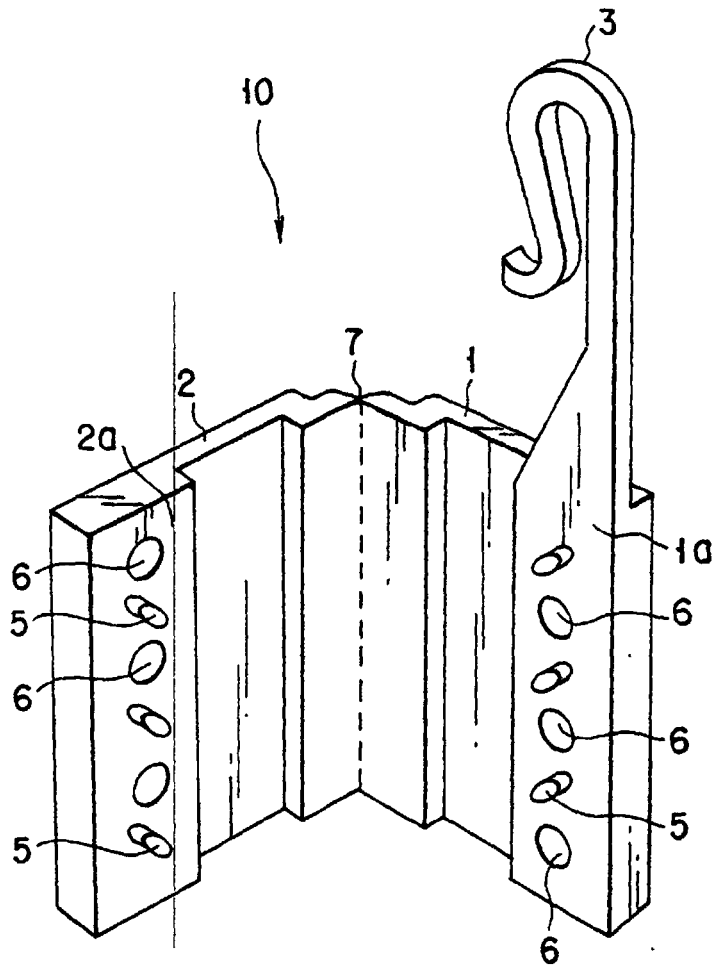

FIG. 10A

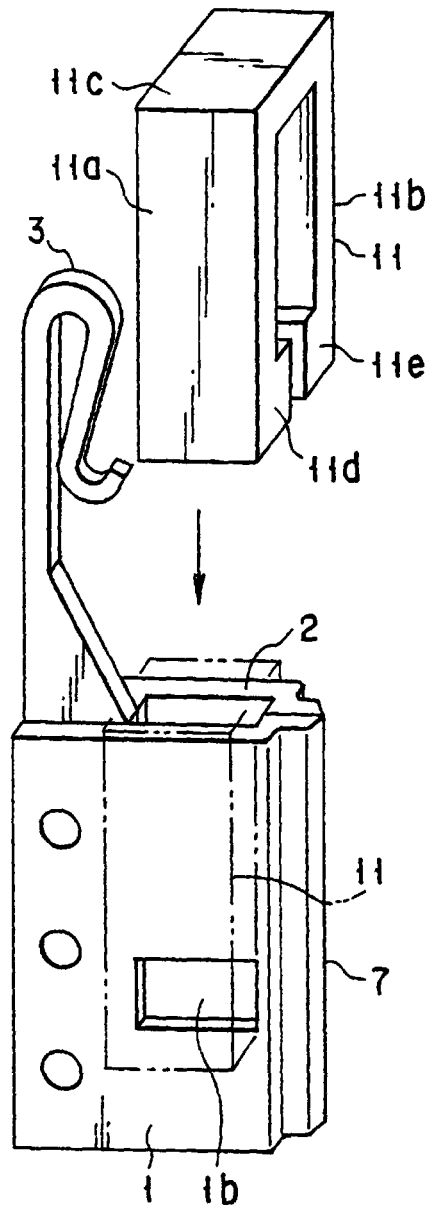

FIG. 10B

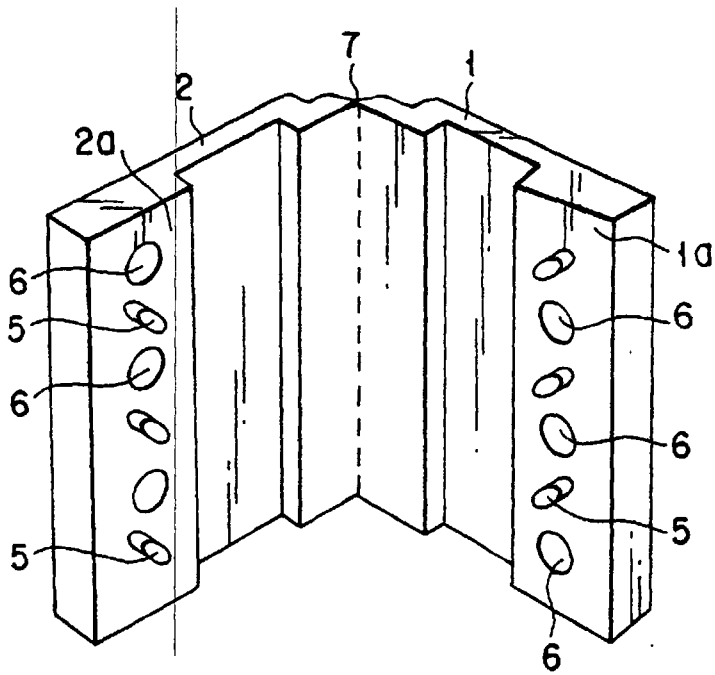

FIG. 11A

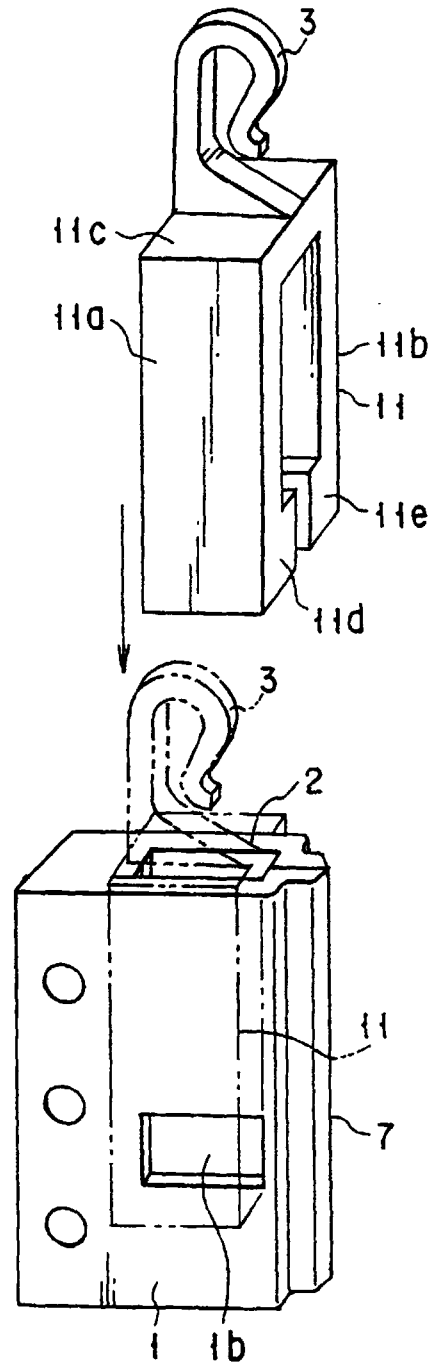

FIG. 11B

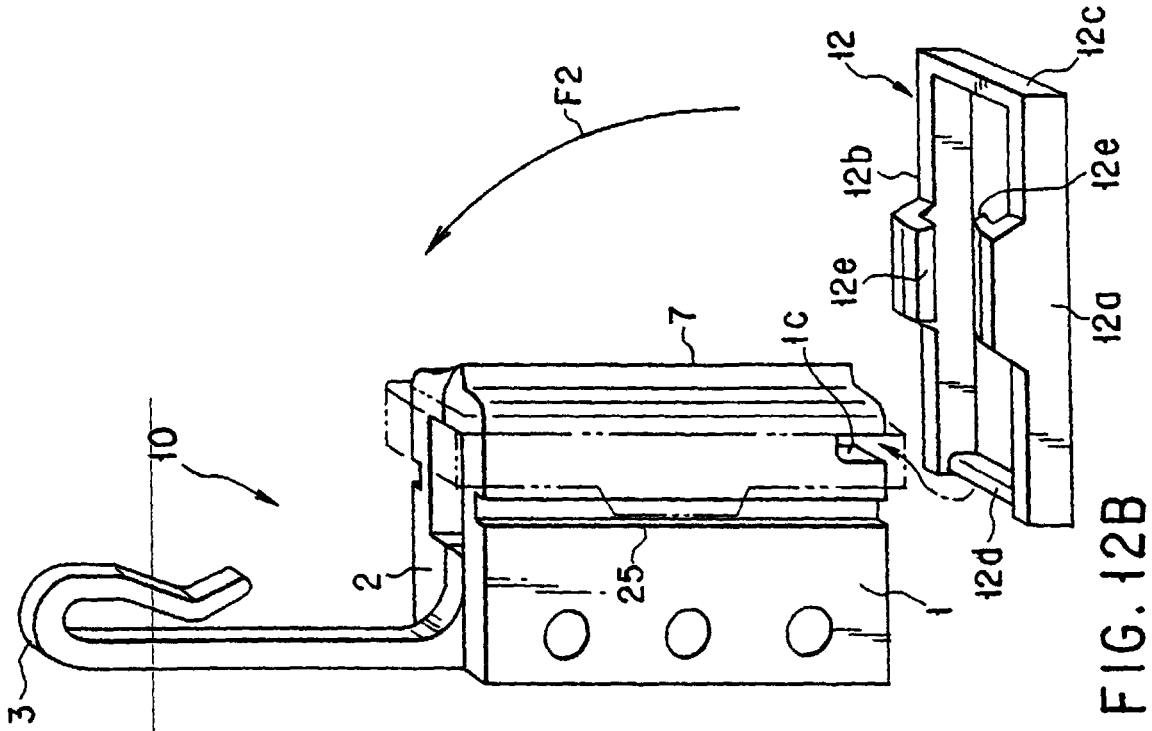

FIG. 12A

FIG. 12B

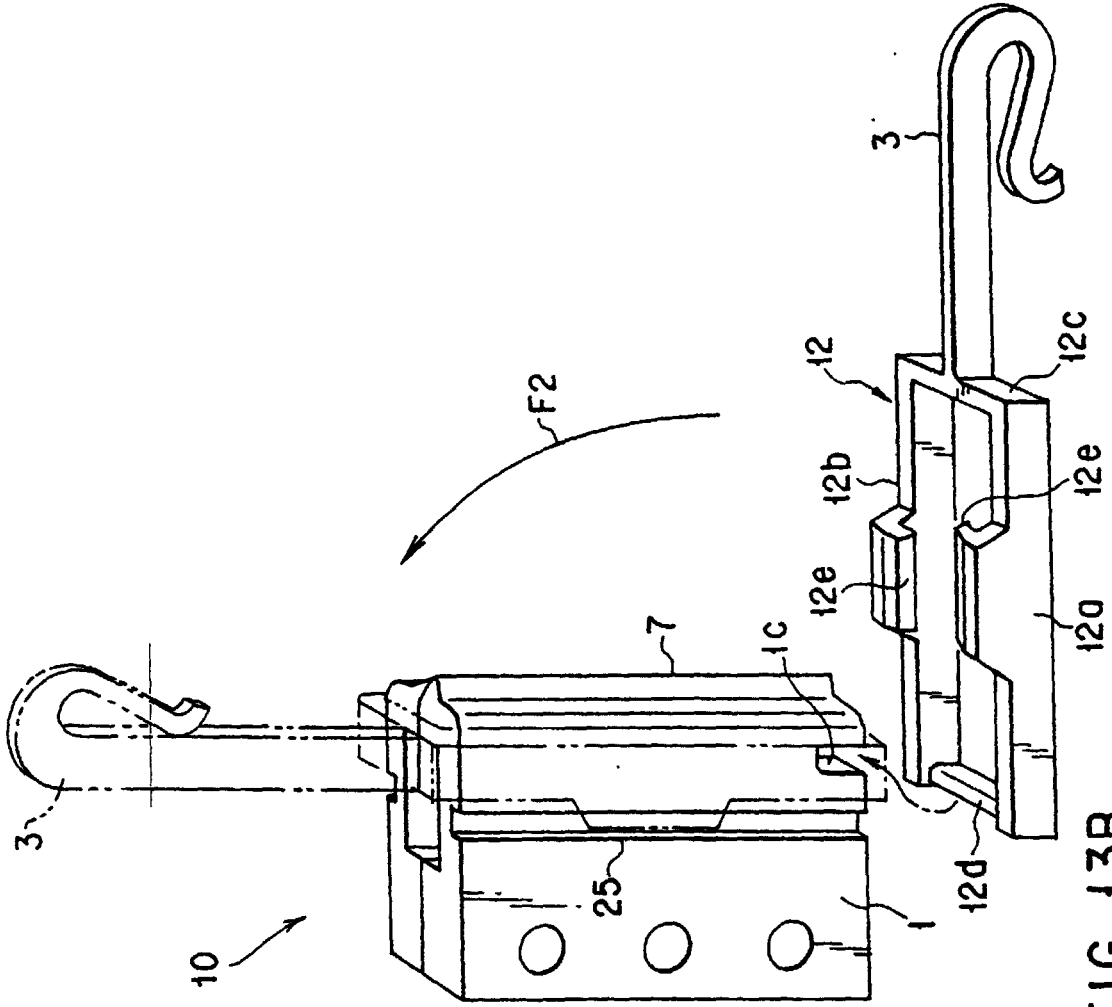

FIG. 13B

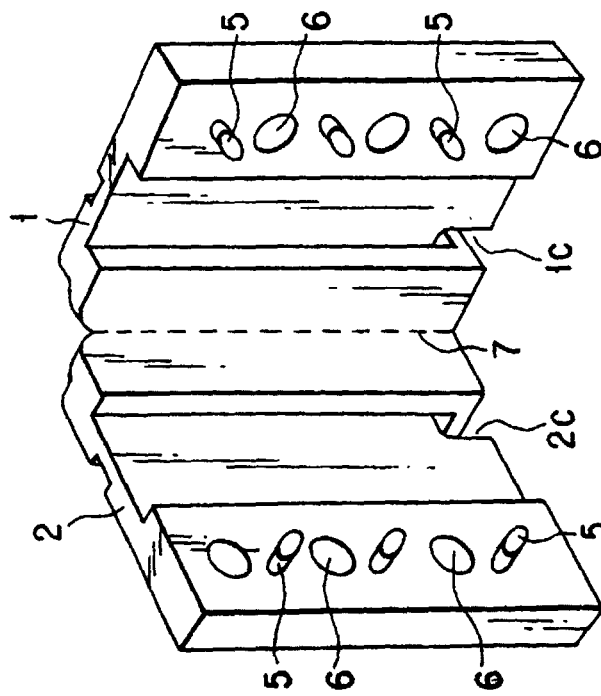

FIG. 13A

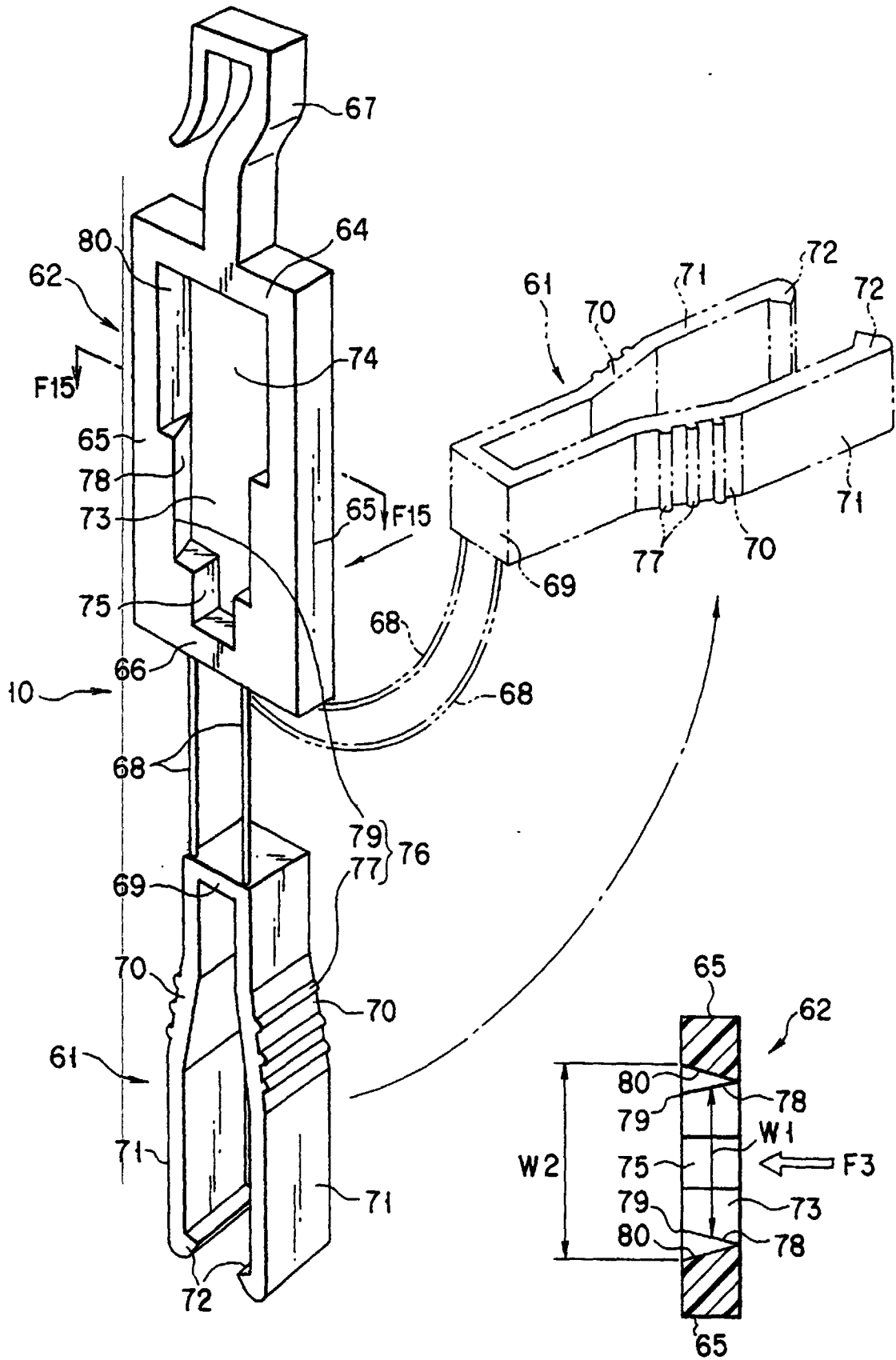

FIG. 14

FIG. 15

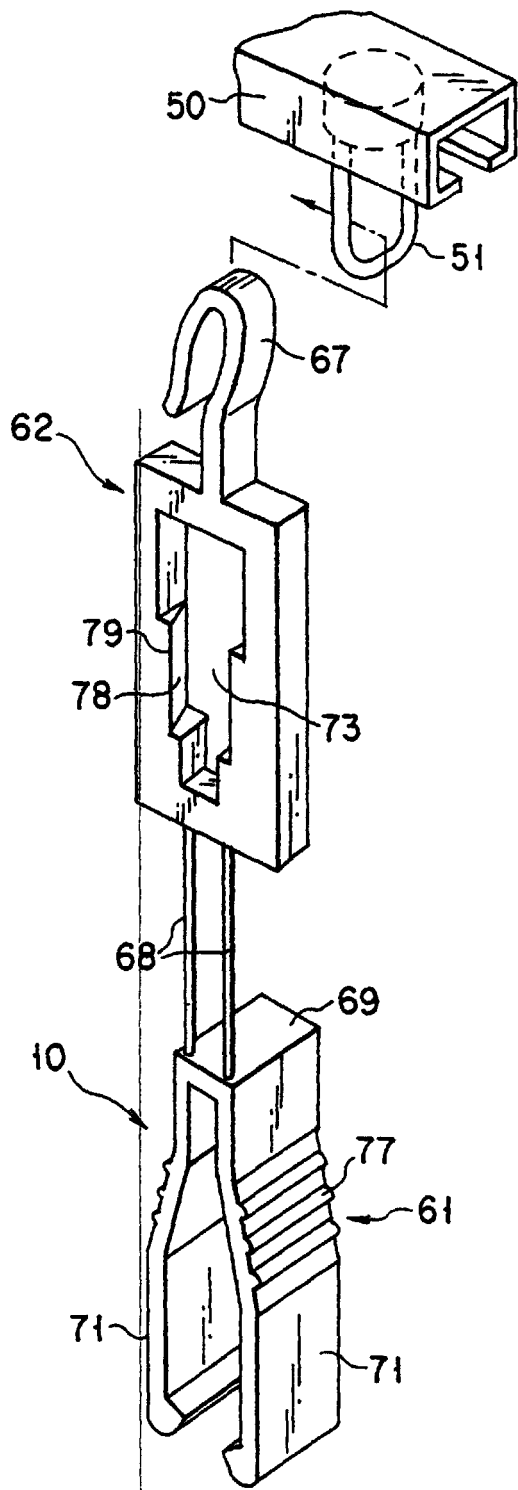

FIG. 16A

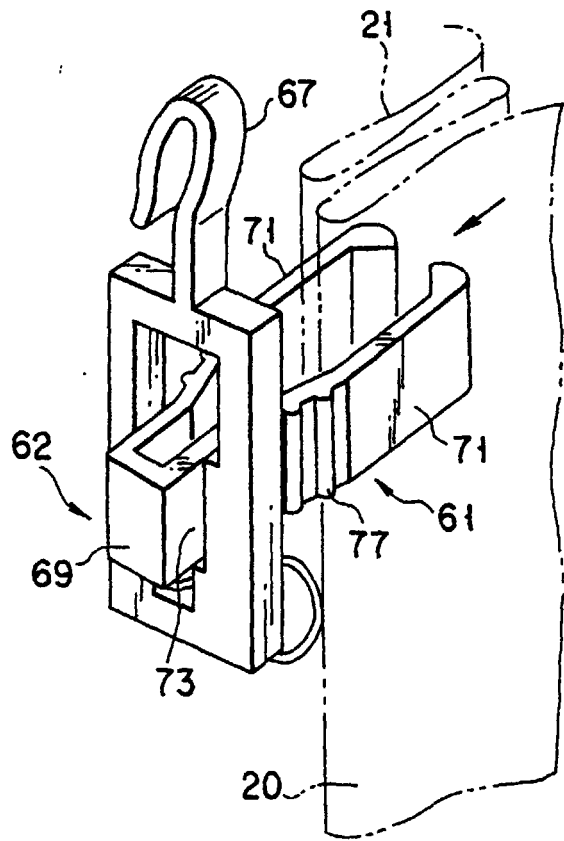

FIG. 16B

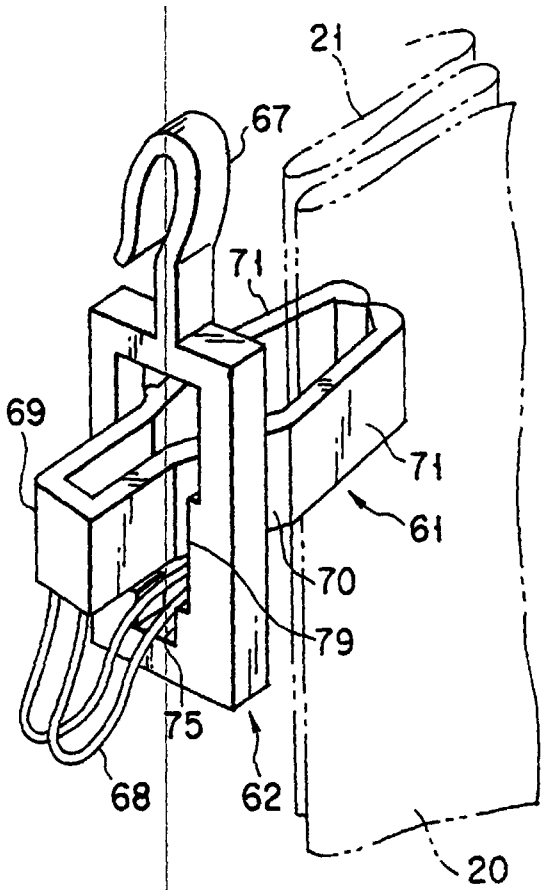

FIG. 16C

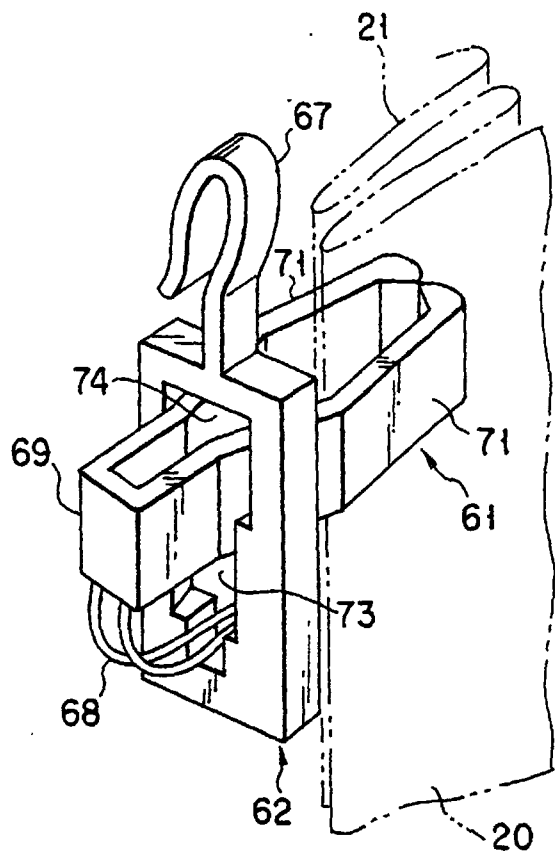

FIG. 16D

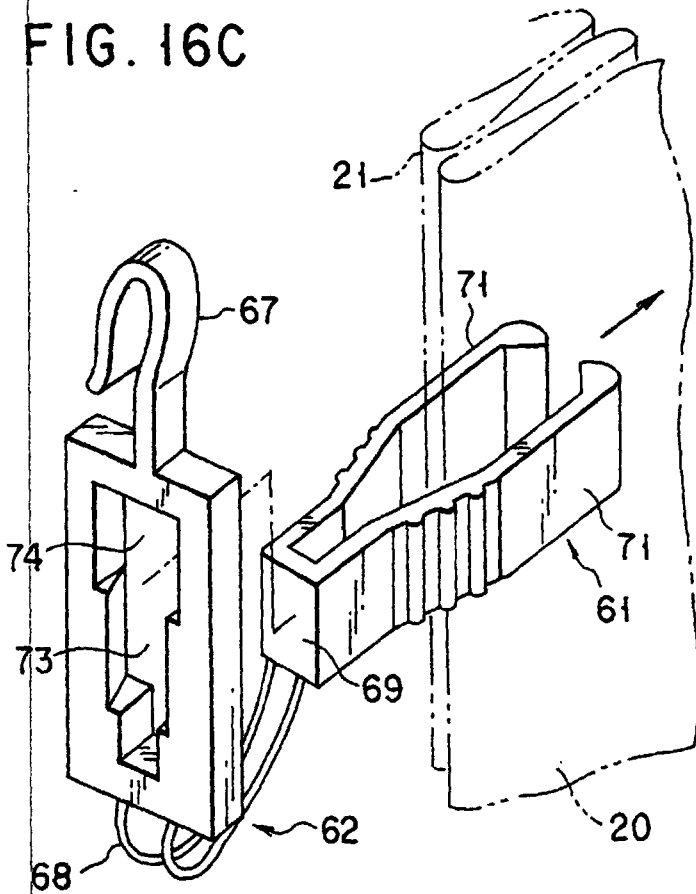
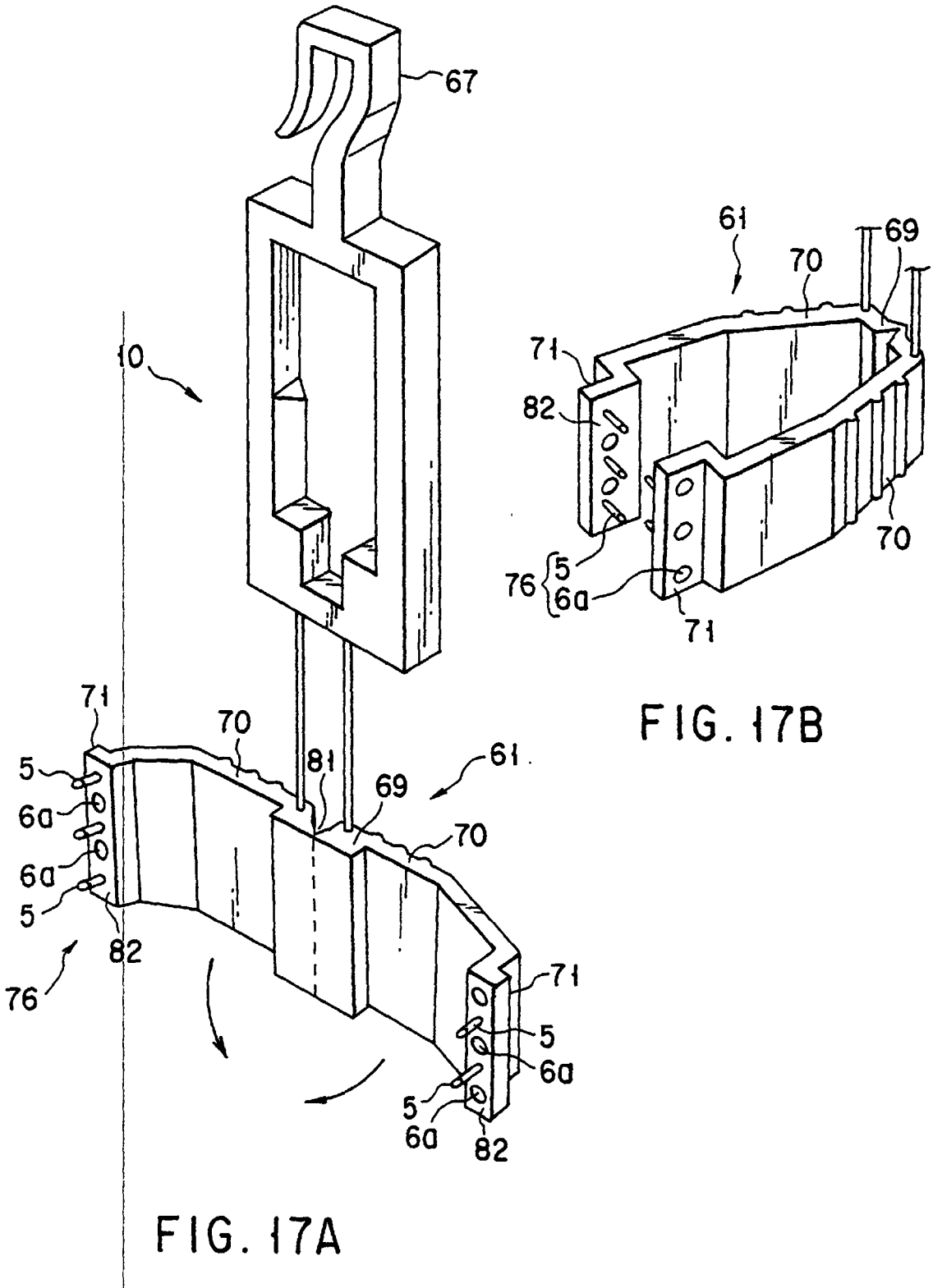

FIG. 16E



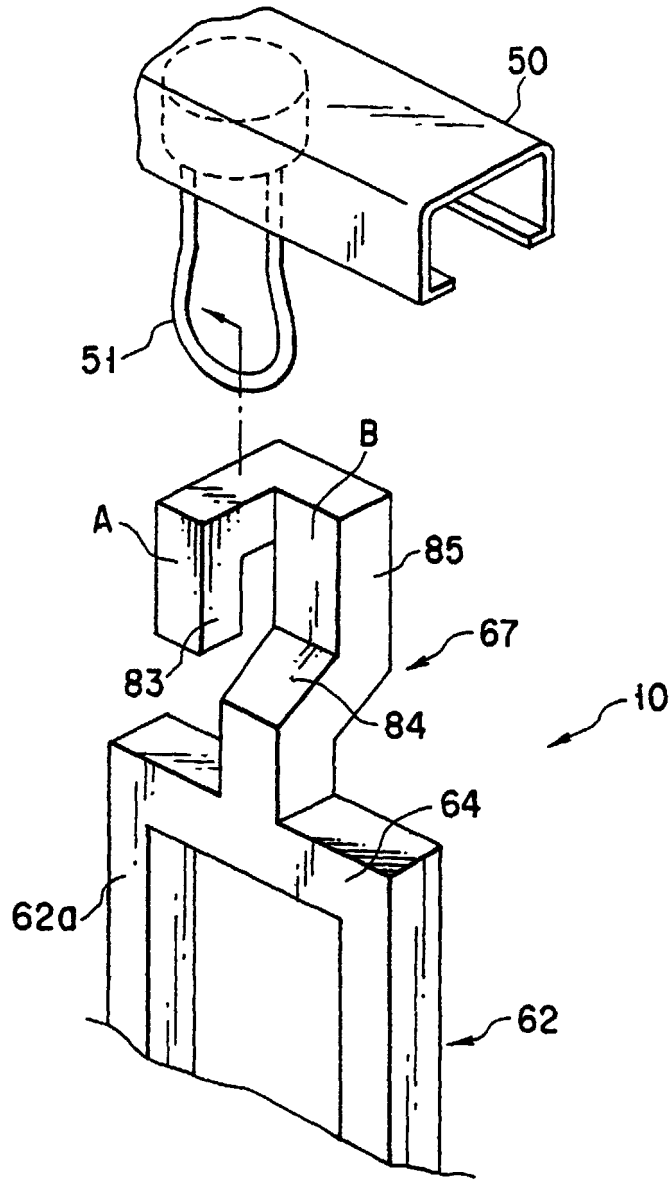
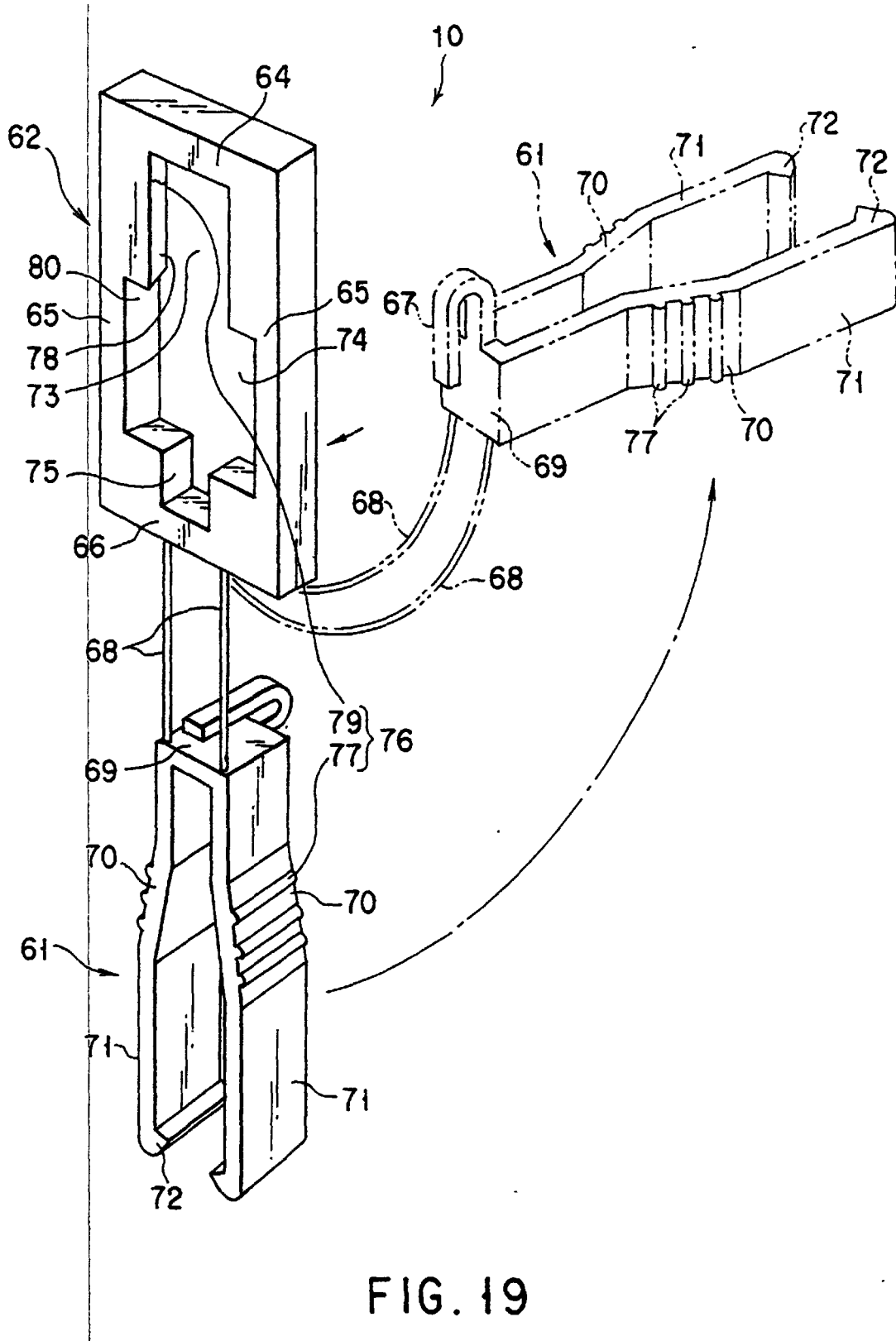

FIG. 18



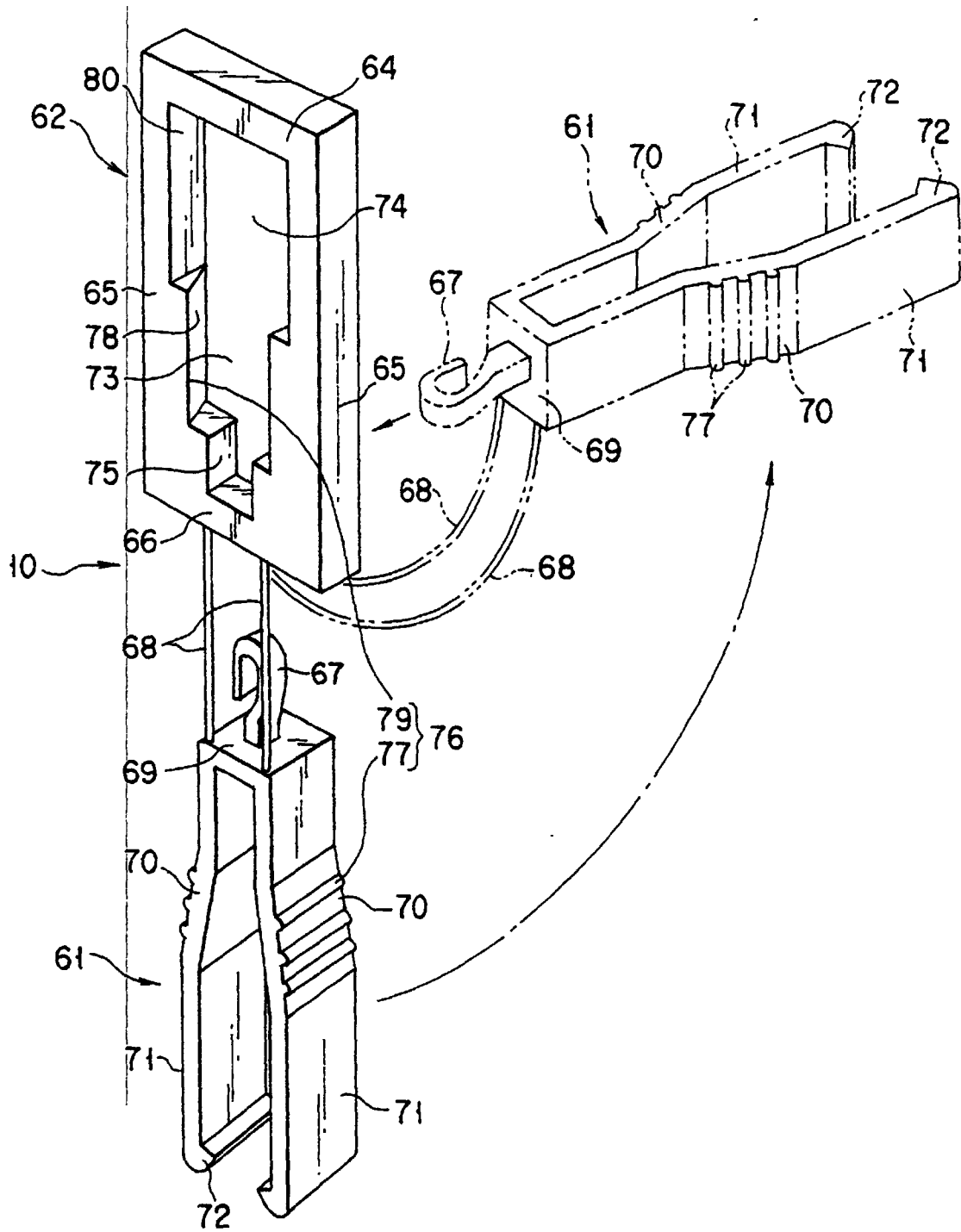
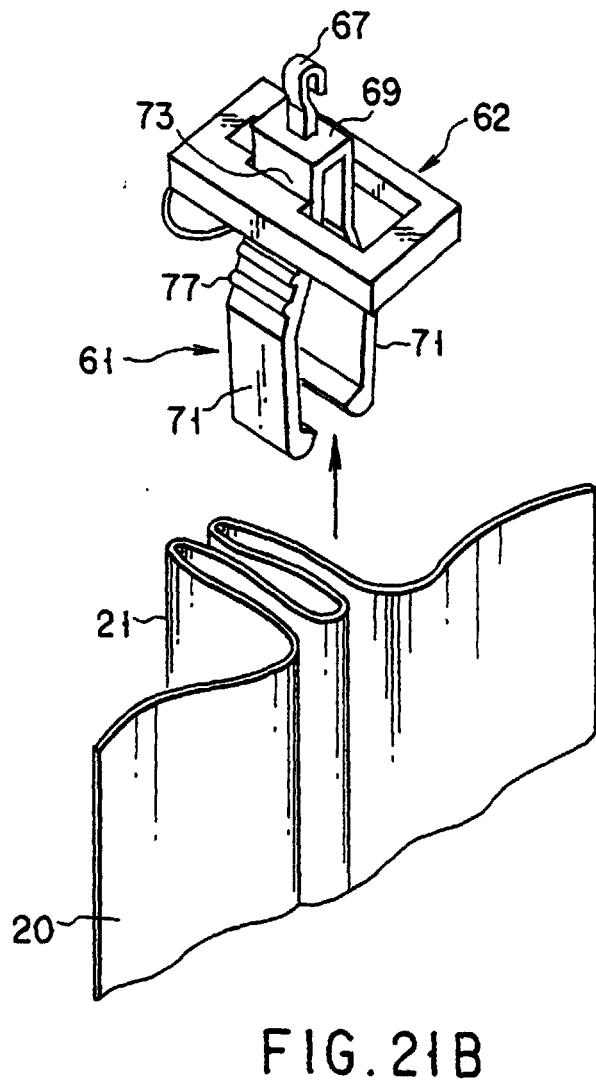
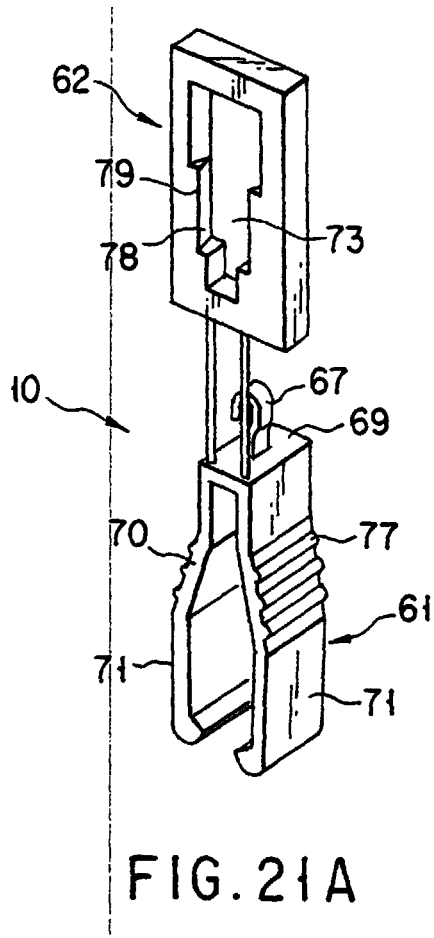

FIG. 20



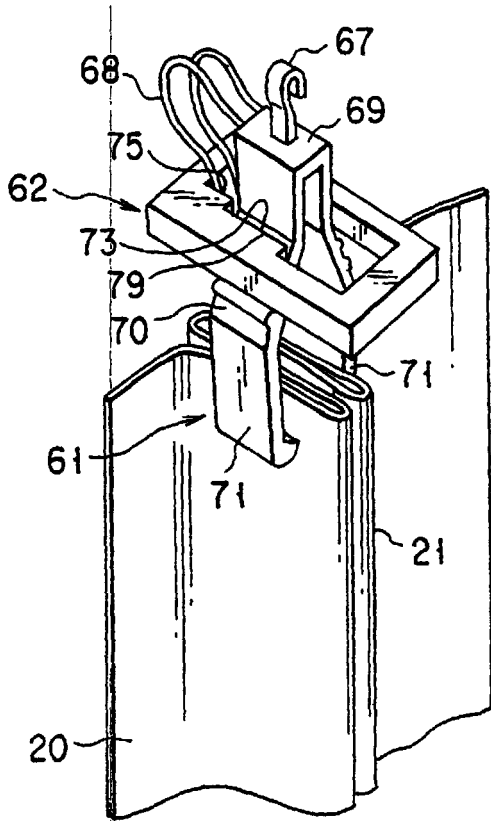

FIG. 21C

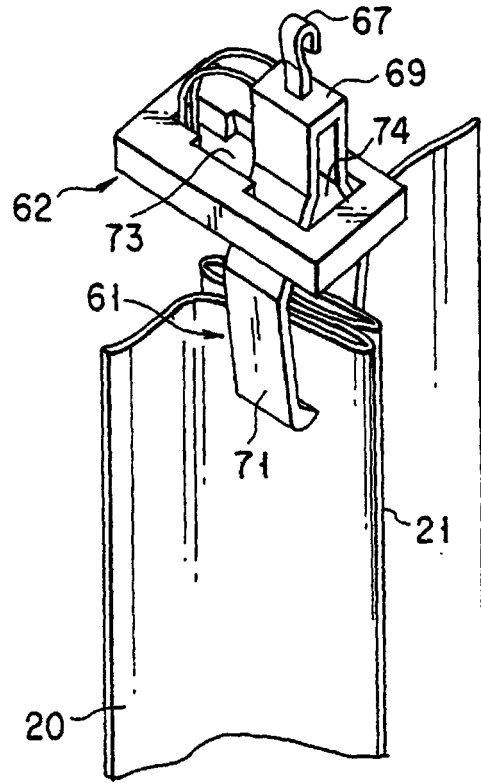

FIG. 21D

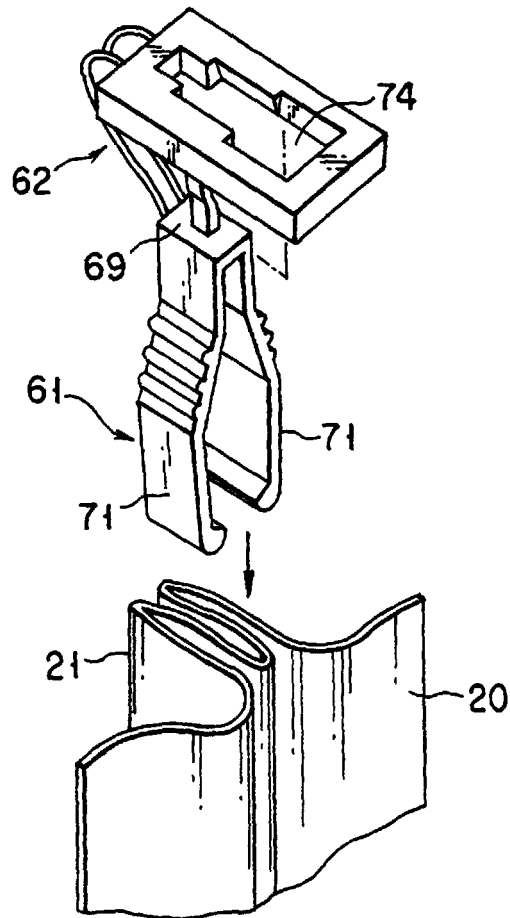

FIG. 21E

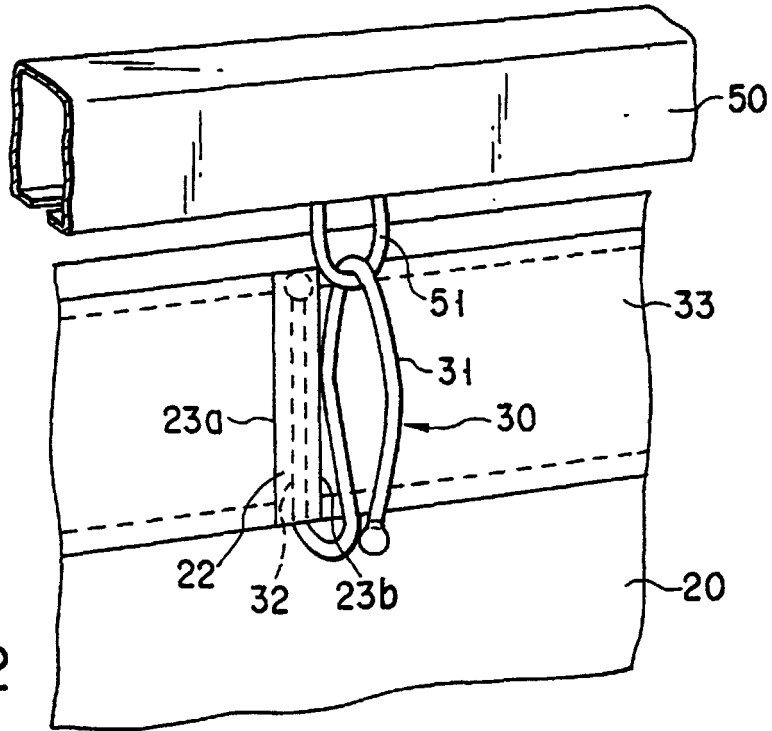

FIG. 22

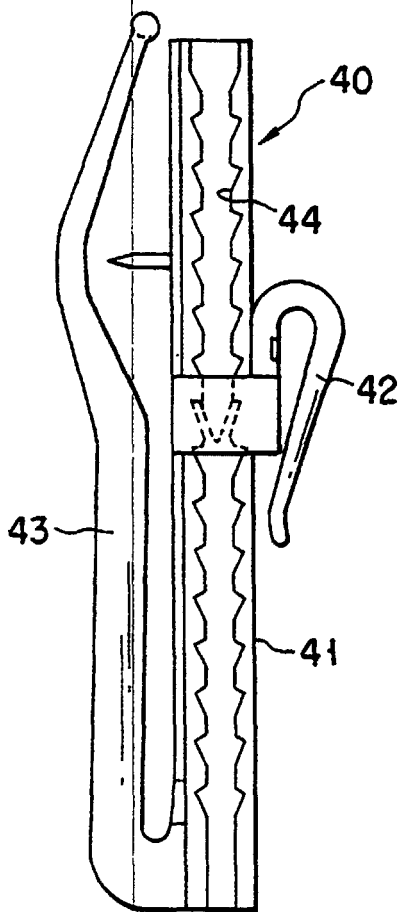

FIG. 23A

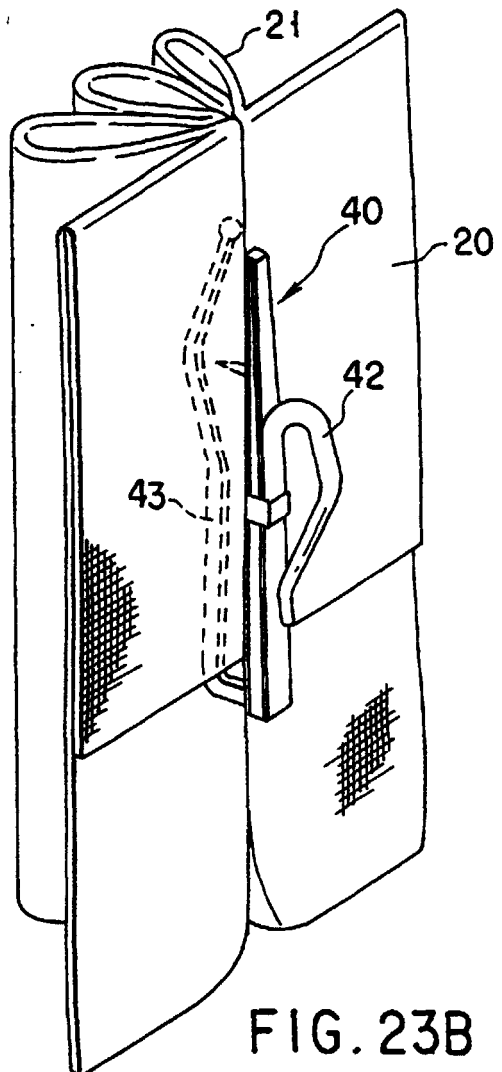

FIG. 23B

INTERNATIONAL SEARCH REPORT

International application No.
PCT/JP99/02201

A. CLASSIFICATION OF SUBJECT MATTER Int.Cl ⁶ A47H13/14		
According to International Patent Classification (IPC) or to both national classification and IPC		
B. FIELDS SEARCHED		
Minimum documentation searched (classification system followed by classification symbols) Int.Cl ⁶ A47H13/00-13/14		
Documentation searched other than minimum documentation to the extent that such documents are included in the fields searched Jitsuyo Shinan Koho 1922-1996 Toroku Jitsuyo Shinan Koho 1994-1999 Kokai Jitsuyo Shinan Koho 1971-1999 Jitsuyo Shinan Toroku Koho 1996-1999		
Electronic data base consulted during the international search (name of data base and, where practicable, search terms used)		
C. DOCUMENTS CONSIDERED TO BE RELEVANT		
Category*	Citation of document, with indication, where appropriate, of the relevant passages	Relevant to claim No.
X Y A	CD-ROM of Japanese Utility Model Application No. 3-110324 (Laid-open No. 5-51178) (K.K. Tekuno Airisu), 9 July, 1993 (09. 07. 93), Full text ; Figs. 1 to 6 (Family: none)	1-3 4, 9, 10 15, 16 5-8, 11-14
X Y	JP, 51-106571, A (Matsushita Electric Works, Ltd.), 21 September, 1976 (21. 09. 76), Full text ; Figs. 1, 2 (Family: none)	1, 2 3, 4, 9, 10, 15, 16
X Y	JP, 8-238166, A (Junko Matsumoto), 17 September, 1996 (17. 09. 96), Full text ; Figs. 1 to 23 (Family: none)	1, 2, 3 4, 15, 16
Y	Microfilm of the specification and drawings annexed to the request of Japanese Utility Model Application No. 51-120378 (Laid-open No. 53-38520) (K.K. Daiki), 4 April, 1978 (04. 04. 78), Full text ; Figs. 1 to 16 (Family: none)	15, 16
<input checked="" type="checkbox"/> Further documents are listed in the continuation of Box C. <input type="checkbox"/> See patent family annex.		
* Special categories of cited documents: "A" document defining the general state of the art which is not considered to be of particular relevance "E" earlier document but published on or after the international filing date "L" document which may throw doubts on priority claim(s) or which is cited to establish the publication date of another citation or other special reason (as specified) "O" document referring to an oral disclosure, use, exhibition or other means "P" document published prior to the international filing date but later than the priority date claimed		"T" later document published after the international filing date or priority date and not in conflict with the application but cited to understand the principle or theory underlying the invention "X" document of particular relevance; the claimed invention cannot be considered novel or cannot be considered to involve an inventive step when the document is taken alone "Y" document of particular relevance; the claimed invention cannot be considered to involve an inventive step when the document is combined with one or more other such documents, such combination being obvious to a person skilled in the art "&" document member of the same patent family
Date of the actual completion of the international search 7 June, 1999 (07. 06. 99)		Date of mailing of the international search report 15 June, 1999 (15. 06. 99)
Name and mailing address of the ISA/ Japanese Patent Office		Authorized officer
Facsimile No.		Telephone No.

Form PCT/ISA/210 (second sheet) (July 1992)

INTERNATIONAL SEARCH REPORT

International application No.

PCT/JP99/02201

C (Continuation). DOCUMENTS CONSIDERED TO BE RELEVANT		
Category*	Citation of document, with indication, where appropriate, of the relevant passages	Relevant to claim No.
Y	Microfilm of the specification and drawings annexed to the request of Japanese Utility Model Application No. 47-102928 (Laid-open No. 49-59815) (Ryouetsu Matsufuchi), 25 May, 1974 (25. 05. 74), Full text ; Figs. 1 to 4 (Family: none)	15, 16

Form PCT/ISA/210 (continuation of second sheet) (July 1992)