



(12) EUROPEAN PATENT APPLICATION

(43) Date of publication:
07.03.2001 Bulletin 2001/10

(51) Int. Cl.⁷: B41F 13/02

(21) Application number: 00306343.5

(22) Date of filing: 26.07.2000

(84) Designated Contracting States:
AT BE CH CY DE DK ES FI FR GB GR IE IT LI LU
MC NL PT SE
Designated Extension States:
AL LT LV MK RO SI

(72) Inventor: Moersfelder, Bradly
Waukesha, Wisconsin 53188 (US)

(30) Priority: 19.08.1999 US 377345

(74) Representative:
Allman, Peter John et al
MARKS & CLERK,
Sussex House,
83-85 Mosley Street
Manchester M2 3LG (GB)

(71) Applicant: QUAD/TECH, INC.
Sussex, WI 53089 (US)

(54) Web position control system

(57) A method and apparatus for controlling the lateral and longitudinal position of the web (16) with respect to various processing units (20,22,24,26) oper-

ating on the web (16) using a correlation between scanned image data and reference image data.

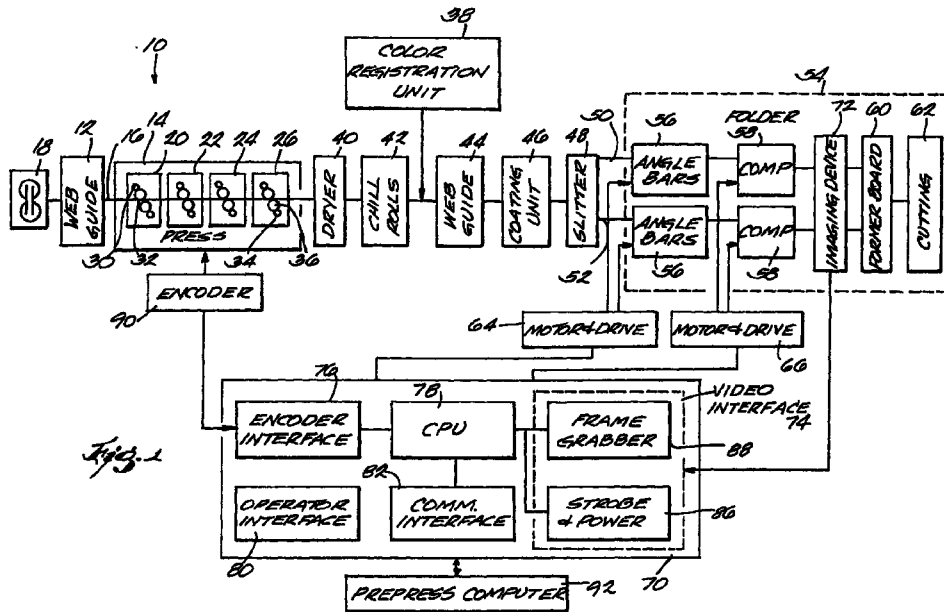

DescriptionFIELD OF THE INVENTION

[0001] The present invention relates to the field of control systems for web-fed printing press lines. In particular, the invention relates to a system for lateral and longitudinal position control of the web with respect to various processing units operating on the web.

BACKGROUND OF THE INVENTION

[0002] In a typical multi-color web-fed printing press line, a web of material (e.g., paper) is sequentially driven through a plurality of printing units. Each printing unit applies a different color ink to the web to produce a multi-color printed image. The web is typically routed through a thermal dryer which dries the ink and then to a series of chill rolls which operate to cool the web and set the ink. A slitter slits the web longitudinally (i.e., in a direction parallel to the direction of web movement) into two or more ribbons. Thereafter, the ribbons are directed to a folder where they are aligned one on top of the other and then folded longitudinally. A cutting mechanism, including a pair of cutting cylinders, and a compensator controlled by a cutoff control system, operate to cut the ribbons in a direction transverse to the direction of web movement. As described, the printing press line outputs a number of "signatures", each consisting of eight or more pages. The signatures are subsequently processed off-line into magazines, catalogs, or the like. Of course, the above merely describes a typical printing press line and it is to be understood that many variations of a printing line are possible.

[0003] A cutoff control system typically operates to control the length of the longitudinal path of the web such that the cutting cylinders cut the web at the appropriate time in order to properly separate the repeating images printed on the web. Early cutoff control systems operate with control marks separate from the desired printed image or "work". These control marks, in conjunction with a scanner and a signal from an encoder, are utilized to determine the longitudinal position of the image on the web relative to the cutting cylinders. More recent cutoff control systems, such as those described in U.S. Pat. Nos. 4,736,446, 4,882,764, and 4,885,785, which are assigned to the assignee of the present invention, are also operable in a pattern recognition mode which does not require the use of control marks separate from the desired printed image.

[0004] The cutoff control systems described in the above-mentioned patents operate to periodically adjust the longitudinal positional relationship of the web and the cutting cylinders by controlling the movement of a compensation roller with the use of appropriate control signals. As the web travels in a longitudinal direction, an optical point scanner is used to produce an output signal corresponding to the light reflected from the image

on the web passing underneath. The scanned data from the scanned portion of the image is digitally correlated in one dimension with reference data previously stored in memory in order to generate a control signal indicative of the longitudinal offset between the scanned portion and the reference image. The relevant portion of the image used in the correlation is a one dimensional strip of the image extending in the longitudinal direction (essentially the portion of the image passing within the field of view of the point scanner).

[0005] The resultant control signal is fed to a compensation motor which controls the position of a compensation roller. The compensation roller and a pair of cooperating idler rollers are interposed in the web path upstream of the cutting mechanism. The compensation motor is responsive to the control signal and selectively adjusts the position of the compensation roller such that the effective length of the web path between the printing units and the cutting cylinders is increased or decreased as necessary. In this manner, cutoff at the appropriate location between repeating printed images on the web is achieved. Thus, once the proper cutoff is achieved, the cutoff control system is intended to operate so as to maintain that cutoff position.

[0006] A disadvantage of the cutoff control system just described is that, depending on the printed image, the system may be somewhat intolerant of lateral web weave. In other words, the point scanner may be placed in a selected lateral position with respect to the printed image on the web such that lateral web weave may cause inaccurate results in terms of cutoff because as the web moves laterally, the portion of the printed image that the scanner sees will change.

[0007] In the typical printing system, an in-feed web guide operates to laterally position the web fed to the printing units such that the image is nominally printed on the web at a desired location. For example, it may be desired to center the image on the web. A chill web guide located before the slitter operates to position the web with respect to the slitter using the edge of the web as a reference. The slitter operates to longitudinally slit the web at one or more predetermined lateral positions. For example, a single slit may be made at the center of the web. The slitting process thus occurs relative to the edge of the web, or indirectly relative to the expected position of ink on the web.

[0008] Similarly, the folder operates to fold the ribbons at a predetermined lateral position relative to the expected position of ink on the ribbons using a ribbon edge as a lateral position reference. Generally, the desired fold location is not at the center of the ribbon because it is often desired that one ribbon edge overlap the other in order to facilitate signature handling during subsequent off-line finishing processes.

[0009] Such printing lines operate with web speeds of approximately 1600 feet per minute or greater. At these high speeds, the web may undergo lateral shifts at various points along the printing line. Lateral shifts of

the web occurring between the in-feed web guide and the printing units cause the actual lateral position of the ink on the web (as measured with respect to a web edge) to vary from its expected position. Similarly, lateral shifts of the web can occur between the printing units and the folder. Because the folder operates relative to the expected position of ink on the web by using the web edge as a lateral position reference, when the actual lateral position of ink differs significantly from its expected position, the fold location is not in the right place with respect to the printed image.

SUMMARY OF THE INVENTION

[0010] The present invention improves the output quality of the printed product and solves the problems described above with a control system that operates to position the web to be cut and folded relative to the actual position of ink on the web.

[0011] It is an object of the present invention to position a web laterally with respect to a folder or a slitter using the image printed on the web as a reference rather than using the ribbon edge as a reference. It is an additional object of the present invention to accurately position the web longitudinally with respect to a device operating on the web such as the cutting cylinders while improving tolerance to web weave.

[0012] Other features and advantages of the invention will become apparent to those of ordinary skill in the art upon review of the following detailed description, claims, and drawings.

BRIEF DESCRIPTION OF THE DRAWINGS

[0013]

Fig. 1 is a schematic view of a web-fed printing press line in accordance with a preferred embodiment of the present invention;

Fig. 2 is a schematic perspective view of a portion of the printing press line of Fig. 1; and

Fig. 3 is an illustration of the relevant portions of an image used in the present invention.

[0014] Before one embodiment of the invention is explained in detail, it is to be understood that the invention is not limited in its application to the details of the construction and the arrangements of components set forth in the following description or illustrated in the drawings. The invention is capable of other embodiments and of being practiced or being carried out in various ways. Also, it is to be understood that the phraseology and terminology used herein is for the purpose of description and should not be regarded as limiting.

DESCRIPTION OF THE PREFERRED EMBODIMENT

[0015] Illustrated in Fig. 1 is a web-fed printing press line 10 including an in-feed web guide 12 and a printing press 14. A web 16, typically paper, is fed from a reel stand 18 through web guide 12 to the printing press 14. The direction of web motion through the press line 10 is called the longitudinal or circumferential direction. The lateral web direction is defined as substantially perpendicular to the longitudinal direction.

[0016] Printing press 14 comprises a plurality of serially disposed conventional printing units 20, 22, 24, 26. In the preferred embodiment, each of the printing units 20, 22, 24, 26 includes an upper blanket cylinder 30, an upper plate cylinder 32, a lower blanket cylinder 34, and a lower plate cylinder 36, as is well known in the art. Printing units 20, 22, 24, 26 cooperate to print multi-color images on both the upper and lower surfaces of web 16. Each printing unit 20, 22, 24, 26 prints an associated color of ink; typically, printing unit 20 prints the color black, and subsequent units 22, 24, 26 print the respective colors cyan, magenta, and yellow.

[0017] In order to register the respective printed images generated by each of the individual printing units 20, 22, 24, 26, a color registration unit 38 is employed. For example, color registration unit 38 could be an RGS V unit available from Quad/Tech, Inc. of Sussex, Wisconsin.

[0018] Multi-color images are printed on web 16 by the printing units 20, 22, 24, 26. The desired or nominal placement of these images will vary for different press runs depending on the desired images to be printed and the type of job; i.e., the layout of the pages of the signature on the plate cylinder. During printing, the actual lateral position of the image on the web 16 may be shifted from its nominal position due to reasons such as the lateral movement of the web 16 between the in-feed web guide 12 and the press 14.

[0019] Web 16 is subsequently routed through a thermal dryer 40, a series of chill rolls 42, a chill web guide 44, a coating unit 46, and a slitter 48. Dryer 40 heats the web 16 to evaporate various solvents in the ink. The chill rolls 42 operate to quickly cool the web 16 after the drying step to set the ink. Web guide 44 operates to laterally position the web 16 fed to slitter 48. The coating unit 46 applies a silicone coating to web 16. Slitter 48 operates to slit web 16 longitudinally (substantially parallel to the direction of web motion) into two or more ribbons 50 and 52.

[0020] Referring to Figs. 1 and 2, after exiting slitter 48, ribbons 50 and 52 are fed to a folder 54 which includes angle bars 56 and compensation rollers 58. The ribbons 50 and 52 are aligned one on top of the other and fed to a former board 60 which operates to fold the ribbons 50 and 52 longitudinally. The folder 54 includes a cutting mechanism 62 which operates to cut the folded ribbons 50 and 52 in a direction transverse to the direction of web movement at the appropriate time

in order to properly separate the repeating images on the web.

[0021] Compensation rollers 58, pairs of cooperating idler rollers 65, and angle bars 56 are interposed in the ribbon path upstream of the former board 60 and cutting mechanism 62. The angle bars 56 each have an associated motor and motor drive 64 for effecting movement of the angle bar 56 and thus lateral movement of the web 16. Similarly, the compensation rollers 58 have an associated motor and motor drive 66 for effecting movement of the compensation rollers 58 to increase or decrease the web path thereby effectively changing the longitudinal positional relationship between the printed images on the web and the cutting mechanism 62. The motor drives 64 and 66 both receive control signals from a control system 70 to move the respective motors.

[0022] Referring now to Fig. 1, the control system 70 includes one or more imaging devices 72, a video interface 74, an encoder interface 76, a central processing unit (CPU) 78, an operator interface 80, and a communications interface 82. The control system 70 operates to periodically adjust the longitudinal web path of the ribbons 50 and/or 52 by controlling the movement of a respective compensation roller 58. The control system 70 computes appropriate control signals that are communicated to the associated compensation roller motor drives 66.

[0023] The control system 70 also operates to periodically adjust the lateral positions of ribbon 50 and/or ribbon 52 with respect to the former board 60 by controlling the movement of the respective angle bar 56. The control system 70 computes appropriate control signals that are communicated to the associated angle bar motor drive 64.

[0024] An imaging device 72 is positioned at each controlled ribbon 50 and/or 52. The imaging device 72 is preferably mounted on a motorized bar 84 such that imaging device 72 is movable in a lateral direction across the ribbon 50 and/or 52. Once the imaging device 72 is laterally positioned, it is operable to "freeze" the printed image on the respective ribbon 50 and 52 at a point to provide scanned image data to the CPU 78 via the interface 74. The scanned image data corresponds to that portion of the printed image within the field of view of the imaging device. As the web moves past the imaging device 72, the imaging device sequentially acquires scanned image data at a series of locations on the web wherein each location corresponds to the same position within the printed image but is at a different longitudinal position on the web. For example, the imaging device 72 in the preferred embodiment is a two dimensional CCD camera with one or more strobes 86. Of course, the imaging device is not limited to CCD technology. The strobe 86 is fired at sequential times to acquire scanned image data at the series of locations. The image on the ribbon 50 or 52 at each point in the series of locations is acquired by a frame grabber 88 and stored. The image acquisition is timed to a pre-

selected angle of rotation (e.g., measured in encoder pulses) after an encoder top dead center (TDC) signal, as further described below.

[0025] A gray scale value is stored for each pixel of that portion of the printed image within the field of view of the imaging device 72. In this manner, an acquired image array is produced. An appropriate camera system which produces image data having gray scale values is described in U.S. Pat. No. 5,724,259, titled "SYSTEM AND METHOD FOR MONITORING COLOR IN A PRINTING PRESS", which patent is hereby incorporated by reference. One difference in the present invention is that the imaging device 72 need not be a color camera, but can be monochrome because processing gray scale values rather than color density values in the control system provides sufficient accuracy for a web position control system. The use of gray scale values increases the accuracy of the correlation algorithms that are described below. However, it is also contemplated that a binary value for each pixel be stored.

[0026] An encoder 90 is mounted to the press line shaft and provides mechanical longitudinal positional information to the control system 70 via the encoder interface 76. Typically, the encoder 90 is geared so that one revolution of a printing cylinder equals one shaft revolution of the encoder 90. The output signal from the encoder 90 includes a series of pulses and includes the TDC reference signal that acts as a marker signal indicative of a repeatable, fixed position in the image printing cycle. Encoder 90 may be any suitable commercially available shaft driven optical encoder.

[0027] The CPU 78 is suitably programmed to carry out the steps described below. The CPU 78 operates to compare reference image data with acquired (or scanned) image data by performing a two dimensional cross-correlation between the two sets of data. The location of the peak in the cross-correlation result provides an indication of the positional amount that the acquired image is offset from the desired image. In this manner, both the longitudinal and lateral alignment errors can be computed. A method for performing cross-correlation is described in U.S. Pat. No. 5,412,577, titled "Color Registration System for a Printing Press", which patent is hereby incorporated by reference.

[0028] The required amounts of lateral and longitudinal web movement are then converted, for example, into thousandths of an inch, and processed in a control loop to determine the required amount of movement of the angle bars 56 and/or compensation rollers 58. These amounts are then communicated to the respective motor drives 64 and 66.

[0029] More specifically, as shown in Fig. 2, the longitudinal positional relationship of each respective ribbon 50 and 52 with respect to the cutting mechanism 62 is adjusted by controlling the movement of the ribbon's respective compensation roller 58. The respective com-

compensation motor controls the position of the compensation roller 58. The motor drive 66 for the compensation motor is responsive to the control signal from the control system 70. The control system 70 operates to selectively adjust the position of the compensation roller 58 such that the effective length of the ribbon path between the printing units 20, 22, 24, and 26 and the cutting mechanism 62 is increased or decreased as necessary to cut the web 16 in a direction transverse to the direction of web movement at the appropriate time to separate the repeating images on the ribbons 50 and 52 at the appropriate location.

[0030] With respect to the lateral positioning of the web, each angle bar motor controls the position of a respective angle bar 56. The motor drive 64 for the angle bar motor is responsive to the control signal from the control system 70. The control system 70 operates to enable the selective adjustments of the position of the angle bar 56 such that the lateral position of each ribbon 50 and 52 is moved as necessary to correctly laterally position the printed image on the web with respect to the former board 60. The control system 70 utilizes a representation of the printed image on the web as a reference, rather than using the edge of the ribbon 50 or 52, to analyze whether lateral adjustments to the web 16, and the ribbons 50 and 52 in particular, need to be made.

[0031] The control system 70 is preferably operable in three different modes. The three modes differ with respect to what representation of the printed image is used as to provide the reference image data against which the actual scanned image data of the real time printed images are compared to determine if lateral and/or longitudinal adjustments of the web are necessary. In the present invention, the representation of the printed image can either be derived from a portion of the printed image itself printed during make-ready (first mode), from a mark separate from the work itself or a portion of the work itself that functions essentially as a mark (second mode) or from pre-press data (third mode).

[0032] In the first mode, termed the pattern mode, the control system 70 analyzes and uses a portion of the just printed image within the work itself to determine whether any lateral and/or longitudinal adjustments in the web position need to be made. The control system 70 selects a portion of the printed image itself to be used to provide the reference image data. Reference image data is determined for each ribbon 50 and 52. The control system is operable to determine whether the reference image data is suitable. Suitable reference image data is data that, when auto-correlated with itself, yields a single well-defined correlation peak at the origin.

[0033] Referring now to Fig. 3, in order to determine if an image portion is suitable to provide the reference image data, the following steps are performed. First, a portion of the printed image, designated as portion A_i in

Fig. 3, is selected. The width of portion A_i has dimension F_w , which corresponds to the width of the field of view of the imaging device 72. The length of portion A_i has dimension F_l , which corresponds to the length of the field of view of the imaging device 72. Portion A_i is converted to a digital data array similar in form to that which would be produced by the imaging device and video interface.

[0034] This digital data array is then auto-correlated with itself. A two dimensional auto-correlation result is obtained. A single, well-defined peak is desirable. In other words, the peak in the resulting auto-correlation result must be sharp in both lateral and longitudinal directions. Ideally, the correlation peak would be a maximum at the origin and quickly fall off in both directions. No other points would be near the peak. For example, if a correlation peak is not a single point but instead looks like a mountain ridge, (i.e., the highest points are in a line), portion A_i is unsuitable to provide the reference image data. A ridge in the correlation result means that the reference image data can be shifted along the corresponding ridge line direction while maintaining a peak value. This means that shifts between the acquired image and the reference image along the ridge line are undetectable or difficult to detect. The offset is thus ambiguous. In this case, a second portion $A_{(i+1)}$ is selected and the above steps are repeated until an image portion is found that provides suitable reference image data. A representation of a portion of the printed image within the field of view of the camera and smaller than the field of view of the camera can also function as suitable reference image data.

[0035] After the reference image data corresponding to a printed image portion is determined to be suitable, the imaging device is laterally positioned over the corresponding portion of the image on the web at the beginning of a press run. Next, an operator, via the operator interface 74, manually adjusts the compensation rollers 58 to adjust cutoff with respect to the cutting cylinders 62. The operator manually adjusts the angle bars 56 to adjust the lateral position of the ribbons 50 and 52 with respect to the folder 54 to achieve the appropriate lateral positioning of the image on the web.

[0036] After the desired longitudinal and lateral positions are determined, the control system 70 operates to maintain that cutoff and sidelay register by using the selected image portion to provide reference image data. In particular, the reference image data is compared to the acquired image data by performing cross-correlation. As described, acquired image data is obtained by the imaging device 72 at a series of locations as the ribbons 50 and 52 pass by. In the preferred embodiment, the acquired image data and the reference image data are in array format. The location of the peak with respect to the origin in the cross-correlation result is an indication of the lateral offset and/or longitudinal offset. The lateral offset is converted to a desired movement amount by the CPU 78 and the desired lat-

eral movement amounts are communicated to the respective motor drives 64 so that the motors appropriately move the angle bars 56. The longitudinal offset is converted to a desired movement amount by the CPU 78 and the desired longitudinal movement amounts are communicated to the respective motor drives 66 so that the motors appropriately move the compensation rollers 58.

[0037] In the first mode of operation, the control system 70 enables the lateral and longitudinal adjustment of the ribbons 50 and 52 without requiring that marks be added to the work and without requiring the use of pre-press image data. A limitation of the first mode is that automatic make-ready is not possible. The second and the third modes of operation are capable of automatic make-ready.

[0038] Automatic make-ready involves positioning the compensation rollers 58 with respect to the cutting mechanism 62 such that cutoff is initially obtained upon start-up within a rough range. Automatic make-ready can also similarly be performed with respect to the lateral dimension such that the angle bars are also initially positioned. Automatic make-ready decreases the time, labor and paper required for start-up of a printing job. Specifically, during make-ready, the imaging device 72 is moved to the expected lateral location of the mark and the compensation rollers and/or angle bars are positioned as well. Once the mark is then located by the control system, subsequent operation of the control system 70 run fine-tunes the cutoff position and/or the sidelay position and the compensation rollers 58 and/or angle bars are moved to their desired positions.

[0039] In the second mode of operation, referred to as the mark mode, marks either separate from the work itself or marks that form a portion of the work itself can be used to provide the reference image data. In this mode, the control system 70 is operable to accept as input the location, the size, and the shape of a mark. The imaging device 72 is laterally positioned at the mark location. Automatic make-ready in this second mode is possible by providing initial longitudinal and lateral position information. For example, longitudinal position information in the second mode is provided by knowing the relationship between the TDC signal from the encoder 90 and the cutting cylinder 62. This is an arbitrary, fixed phase angle, which can be determined by known methods.

[0040] Similarly, for sidelay, lateral position information is provided by knowing the relationship between the centerline of the former board 60 and a lateral reference position for the imaging device. This can also be determined.

[0041] The control system 70 accepts as input the desired position of the mark with respect to the position of the desired fold and the desired position of the mark with respect to the position of the desired cutoff. In this manner, automatic make-ready can also be performed by first locating the mark and then positioning the angle

bars 56 with respect to the former board 60 of the folder 54 to obtain initial sidelay positioning within a rough range and positioning the compensation rollers 58 to obtain initial cutoff within a rough range. Subsequent operation of the control system 70 as the press is run fine-tunes the sidelay and cutoff positions.

[0042] The operation of the control system 70 during press run-time for the second mode includes using as reference image data a representation of the portion of the image that includes the mark. Image data is acquired by the imaging device 72 at a series of corresponding locations as the ribbons 50 and 52 pass by the imaging device. The acquired image data is then compared to the reference image data by cross-correlation. The acquired image data and the reference image data are preferably in array format. The location of the peak in the cross-correlation result with respect to the origin of the reference image data provides an indication of the lateral and longitudinal offsets. The offsets are converted by the CPU 78 to desired movement amounts and these are communicated to the respective angle bars 56 and/or compensation rollers 58.

[0043] The third mode of operation also achieves automatic make-ready, but without the use of marks separate from the work. In the third mode, use is made of pre-press image data. The pre-press image data is analyzed to determine suitable reference image data. The control system 70 operates to provide automatic make-ready, i.e., rough positioning, for cutoff and sidelay register without the use of marks.

[0044] In particular, the control system 70 communicates with a pre-press computer 92 via the communication interface 82. The pre-press computer 92 includes memory for storing digital pre-press data. The digital pre-press data is preferably in a format representative of the colors and the location of the colors making up the desired image to be printed. This data is typically available in array format. For example, direct-to-plate systems are currently available which utilize the digital pre-press data to directly produce the printing plates used to print the desired image. For a four color ink printing process, four separate arrays representative of the four ink colors (black, cyan, magenta, and yellow) are available from the direct-to-plate system and contain information regarding ink location for the desired image. The digital pre-press data could also be obtained by scanning either a printing plate or a proof of the desired image.

[0045] In the third mode of operation, the reference image data is converted from the pre-press data format into a format that is the same as that produced by the imaging device 72 scanning the printed image. If a monochrome camera is used, the response of this camera to the various ink colors making up the printed image would need to be known so that the pre-press data can be correctly converted to the format of the imaging device.

[0046] Similar to the first mode, in the third mode of

operation, a suitable portion of the image to be used to provide reference image data is first selected. The steps described above in connection with the first mode are also used in the third mode to determine suitable reference image data. In other words, a portion of the printed image is selected, converted to a digital data array, the digital data array is auto-correlated with itself to produce an auto-correlation result, and it is determined whether or not a single correlation peak exists at the origin of the auto-correlation result. Reference image data determined to be suitable is then stored.

[0047] The operation of the control system 70 during press run-time for the third mode is essentially the same as for the first and second modes. Additional information required by the CPU 78 includes the distance from the point in the printed image corresponding to the origin of the reference image data to the desired cut position (or encoder TDC position) and the distance from point in the printed image corresponding to the origin of the reference image data to the desired fold position (or other camera reference point).

[0048] The invention provides the following advantages. In most cases, no separate cutoff or sidelay marks need to be added to the web. Detecting and analyzing the ink of the printed image itself rather than the ribbon edge overcomes the numerous disadvantages of edge-based sidelay systems including process dependence on the in-feed web guide and ribbon-weave-associated problems between the in-feed web guide and the printing units that affect sidelay. A single imaging device in the present invention obtains data that is analyzed to selectively adjust both the longitudinal and lateral position of the respective ribbons. A second imaging device is therefore not necessary to obtain the ribbon edge measurement. The present invention is very tolerant of lateral web shifts and is able to adjust the angle bars to compensate for lateral web shifts.

[0049] It is also contemplated that the invention pertain to various printing system setups. For example, the invention is applicable to a control system for relating the lateral position of a slit to the repetitive images printed on the web. The invention is also applicable to a control system for relating the actual image printed on the web to any web processing unit wherein lateral positioning is important.

[0050] Various other features and advantages of the invention are set forth in the following claims.

Claims

1. A method for relating repetitively printed images on a longitudinally moving web to a cutoff operation and a lateral machine operation, the cutoff operation having associated therewith a first adjustment device responsive to a first control signal applied thereto for varying the longitudinal relationship of the cutoff operation to the web, the lateral machine operation having associated therewith a second

adjustment device responsive to a second control signal applied thereto for varying the lateral relationship of the lateral machine operation to the web, the method comprising:

selecting and storing reference image data representing a selected two dimensional portion of the printed image;
 scanning the selected portion of the printed image on the web to produce scanned image data;
 correlating the scanned image data with the reference image data to produce a correlation array;
 determining the position of the peak in the correlation array and generating the first control signal for the first adjustment device and the second control signal for the second adjustment device; and
 communicating the first and second control signals to the respective first and second adjustment devices.

2. The method as recited in claim 1 wherein the selecting step includes analyzing an auto-correlation result.

3. The method of claim 1 wherein the selecting step includes:

(a) selecting a first portion of the printed image to provide potential reference image data;
 (b) auto-correlating the potential reference image data to obtain a two dimensional auto-correlation result;
 (c) determining whether a single peak exists in the auto-correlation result;
 (d) if a single peak exists in the auto-correlation result, designating the potential reference image data as the reference image data; and
 (e) if more than a single peak exists in the auto-correlation result, selecting another portion of the image to provide the potential reference image data and repeating steps (b)-(e).

4. The method of claim 3 wherein the scanning step includes the use of an imaging device and the size of the first portion is equal to the size of the field of view of the imaging device during scanning.

5. The method of claim 1 wherein in the selecting step, the reference image data is derived from the image printed during make-ready.

6. The method of claim 1 wherein in the selecting step, the reference image data is derived from pre-press data.

- 7. The method as recited in claim 1 wherein the scanning step includes the use of a longitudinal reference signal from an encoder.
- 8. The method of claim 1 wherein the scanning step includes the use of a two dimensional imaging device. 5
- 9. The method of claim 1 wherein the correlating step includes the use of cross-correlation. 10
- 10. A system for adjusting the lateral position of a longitudinally moving web with respect to a folder of a web-fed printing press line, and for adjusting the effective length of the web between the printing units of the press line and a cutoff operation, the system comprising: 15
 - an angle bar for moving the web in a lateral direction; 20
 - a first motor in communication with the angle bar for laterally moving the angle bar and the web;
 - a compensation roller for changing the effective length of the web in the longitudinal direction between the printing units and the cutoff operation; 25
 - a second motor in communication with the compensation roller for longitudinally moving the compensation roller; 30
 - an imaging device spaced from the web for obtaining two-dimensional scanned image data from the web; and
 - a programmed controller in communication with the motors and the imaging device, the controller operating to analyze the scanned image data to determine if the scanned image data is laterally and longitudinally offset from a desired image location, to communicate with the first motor to move the angle bar to reduce the amount the scanned image data is laterally offset from the desired image location, and to communicate with the second motor to move the compensation roller to reduce the amount the scanned image data is longitudinally offset from the desired image location. 45
- 11. The system as recited in claim 10, wherein the imaging device is a two-dimensional camera. 50
- 12. The system as recited in claim 10, further including a memory disposed to store a reference array of digital data representative of a portion of the printed image, and wherein the controller operates to correlate the reference array with the scanned image data. 55
- 13. The system as recited in claim 12 wherein the con-

troller cross-correlates the reference array with the scanned image data to produce a product array and determines the location of the peak of the product array to determine the lateral and longitudinal offset.

- 14. A method for relating repetitively printed images on a longitudinally moving web to a cutoff operation, the cutoff operation having associated therewith an adjustment device responsive to a control signal applied thereto for varying the longitudinal relationship of the cutoff operation to the web, the method comprising:

- (a) selecting a first portion of the printed image to provide potential reference image data;
- (b) auto-correlating the potential reference image data to obtain a two-dimensional auto-correlation result;
- (c) determining whether a single peak exists in the auto-correlation result;
- (d) if a single peak exists in the auto-correlation result, designating the potential reference image data as the reference image data;
- (e) if more than a single peak exists in the auto-correlation result, selecting another portion of the image to provide the potential reference image data and repeating steps (b)-(e);
- (f) storing the reference image data corresponding to the selected portion of the printed image;
- (g) scanning the selected portion of the printed image on the web to produce scanned image data;
- (h) correlating the scanned image data with the reference image data to produce a correlation array;
- (i) determining the position of the peak in the correlation array and generating the control signal for the adjustment device; and
- (j) communicating the control signal to the adjustment device.

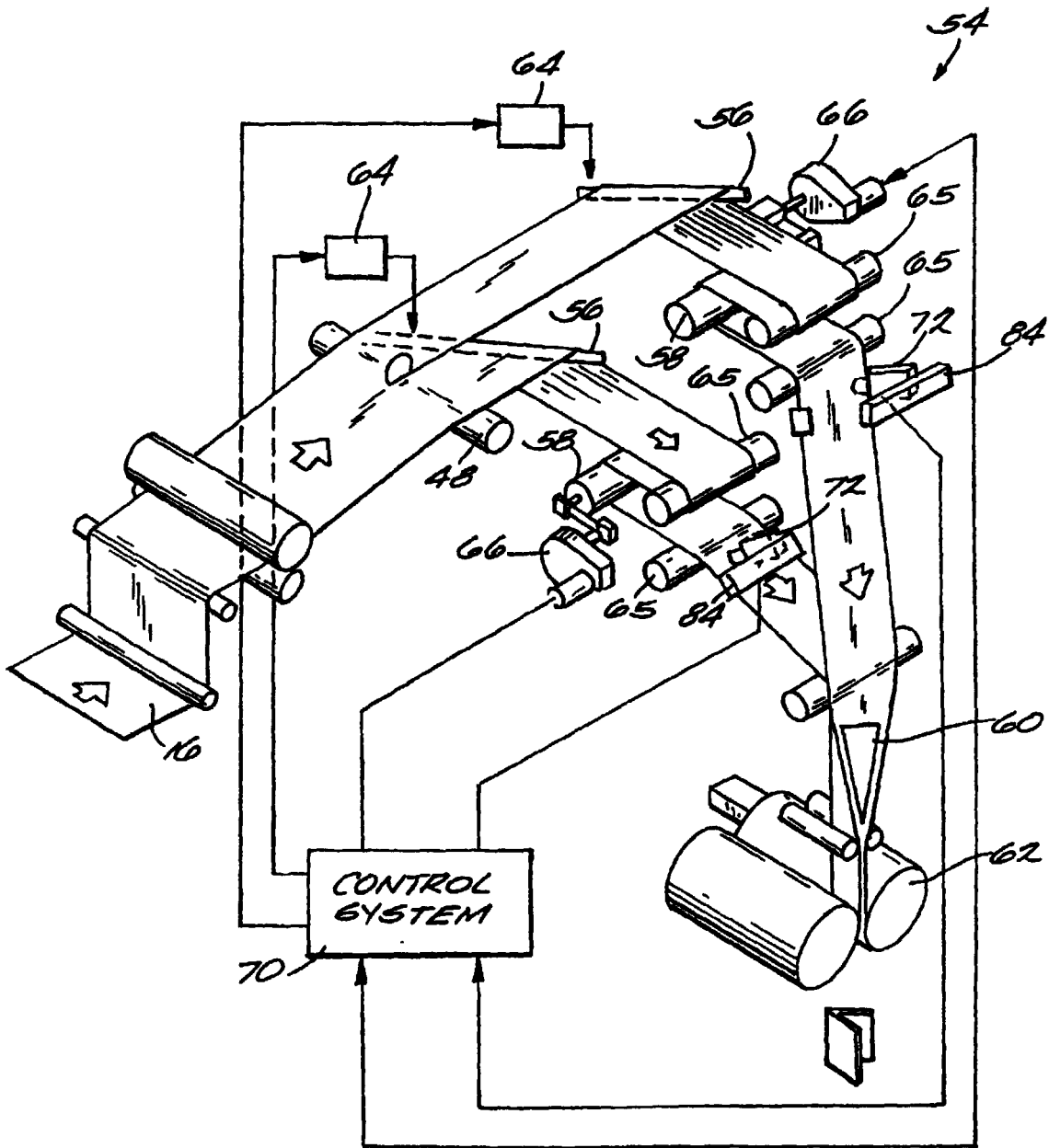
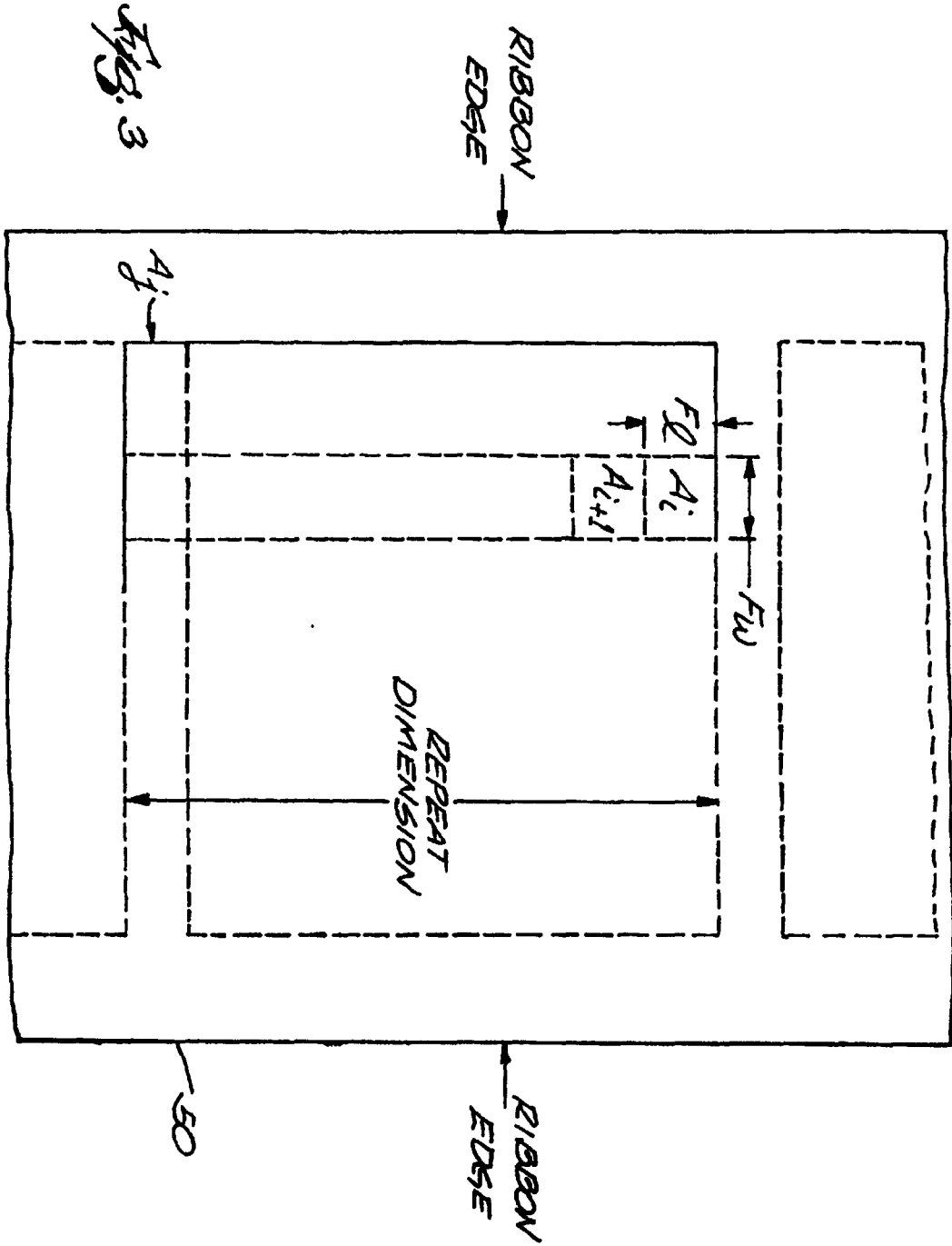

Fig. 2.





European Patent
Office

EUROPEAN SEARCH REPORT

Application Number
EP 00 30 6343

DOCUMENTS CONSIDERED TO BE RELEVANT			
Category	Citation of document with indication, where appropriate, of relevant passages	Relevant to claim	CLASSIFICATION OF THE APPLICATION (Int.CI.7)
X,D	US 4 882 764 A (BRUCE A. REYNOLDS ET AL.) 21 November 1989 (1989-11-21)	14	B41F13/02
Y	see abstract * column 1, line 6 - column 12, line 49; claims 1-10; figure 1 *	1-13	
Y,D	US 5 412 577 A (JEFFREY W. SAINIO ET AL.) 2 May 1995 (1995-05-02)	1-13	
Y	see abstract * column 1, line 12 - column 14, line 14; figures 1-10 *		
Y	EP 0 683 123 A (DE LA RUE GIORI S.A.) 22 November 1995 (1995-11-22)	10-13	
Y	see abstract * column 1, line 1 - column 6, line 46; figures 1-15 *		
A	WO 95 00336 A (HEIDELBERGER DRUCKMASCHINEN AG) 5 January 1995 (1995-01-05)	1-14	
A	* the whole document *		
A	US 4 512 256 A (LOUIS SCHRIBER ET AL.) 23 April 1985 (1985-04-23)	1-14	
A	* the whole document *		
A	EP 0 023 299 A (SIEMENS AKTIENGESELLSCHAFT) 4 February 1981 (1981-02-04)	1-14	TECHNICAL FIELDS SEARCHED (Int.CI.7) B41F
A	* the whole document *		
A	EP 0 288 550 B (QUAD/TECH, INC.) 27 November 1991 (1991-11-27)	1-14	
A	* the whole document *		
A	US 5 048 810 A (ROLAND T. PALMATIER ET AL.) 17 September 1991 (1991-09-17)	1-14	
A	* the whole document *		
The present search report has been drawn up for all claims			
Place of search MUNICH		Date of completion of the search 29 November 2000	Examiner Greiner, E
CATEGORY OF CITED DOCUMENTS		T : theory or principle underlying the invention E : earlier patent document, but published on, or after the filing date D : document cited in the application L : document cited for other reasons & : member of the same patent family, corresponding document	
X : particularly relevant if taken alone Y : particularly relevant if combined with another document of the same category A : technological background O : non-written disclosure P : intermediate document			

EPO FORM 1503 03 82 (P04C01)

**ANNEX TO THE EUROPEAN SEARCH REPORT
ON EUROPEAN PATENT APPLICATION NO.**

EP 00 30 6343

This annex lists the patent family members relating to the patent documents cited in the above-mentioned European search report. The members are as contained in the European Patent Office EDP file on
The European Patent Office is in no way liable for these particulars which are merely given for the purpose of information.

29-11-2000

Patent document cited in search report		Publication date	Patent family member(s)	Publication date
US 4882764	A	21-11-1989	US 4736446 A	05-04-1988
US 5412577	A	02-05-1995	AT 164350 T	15-04-1998
			DE 69317625 D	30-04-1998
			DE 69317625 T	20-08-1998
			EP 0598490 A	25-05-1994
			JP 2829360 B	25-11-1998
			JP 6278274 A	04-10-1994
			US 5689425 A	18-11-1997
EP 0683123	A	22-11-1995	CH 688137 A	30-05-1997
			CA 2148986 A	21-11-1995
			CN 1118306 A	13-03-1996
			DE 59504031 D	03-12-1998
			DK 683123 T	19-07-1999
			RU 2129489 C	27-04-1999
			US 5540146 A	30-07-1996
WO 9500336	A	05-01-1995	DE 4321179 A	05-01-1995
			EP 0705171 A	10-04-1996
			EP 0884178 A	16-12-1998
			EP 0884179 A	16-12-1998
			EP 0884180 A	16-12-1998
			EP 0884181 A	16-12-1998
			EP 0884182 A	16-12-1998
			US 6119594 A	19-09-2000
			US 6050192 A	18-04-2000
US 4512256	A	23-04-1985	US 4177730 A	11-12-1979
			CA 1109331 A	22-09-1981
			DE 2749183 A	18-05-1978
			FR 2369934 A	02-06-1978
			GB 1598190 A	16-09-1981
			GB 1598189 A	16-09-1981
			JP 53063107 A	06-06-1978
EP 0023299	A	04-02-1981	DE 2930438 A	12-03-1981
			DE 3067685 D	07-06-1984
			US 4391190 A	05-07-1983
EP 0288550	B	02-11-1988	AT 69766 T	15-12-1991
			AU 8326287 A	25-05-1988
			CA 1305235 A	14-07-1992
			DE 3774873 A	09-01-1992
			DE 3774873 D	09-01-1992
			DK 359288 A	31-08-1988

EPO FORM P0459

For more details about this annex : see Official Journal of the European Patent Office, No. 12/82

**ANNEX TO THE EUROPEAN SEARCH REPORT
ON EUROPEAN PATENT APPLICATION NO.**

EP 00 30 6343

This annex lists the patent family members relating to the patent documents cited in the above-mentioned European search report. The members are as contained in the European Patent Office EDP file on
The European Patent Office is in no way liable for these particulars which are merely given for the purpose of information.

29-11-2000

Patent document cited in search report	Publication date	Patent family member(s)	Publication date
EP 0288550 B		EP 0288550 A	02-11-1988
		FI 883091 A	28-06-1988
		JP 7050505 B	31-05-1995
		JP 1501694 T	15-06-1989
		NO 882905 A	30-08-1988
		WO 8803091 A	05-05-1988
		US 4885785 A	05-12-1989

US 5048810 A	17-09-1991	NONE	

EPO FORM P0459

For more details about this annex : see Official Journal of the European Patent Office, No. 12/82