



(12) **EUROPEAN PATENT APPLICATION**

(43) Date of publication:  
**07.03.2001 Bulletin 2001/10**

(51) Int Cl.7: **H01R 12/20**

(21) Application number: **99117228.9**

(22) Date of filing: **02.09.1999**

(84) Designated Contracting States:  
**AT BE CH CY DE DK ES FI FR GB GR IE IT LI LU  
MC NL PT SE**  
Designated Extension States:  
**AL LT LV MK RO SI**

(72) Inventor: **Tung, Shyh-Lin**  
**Taiping City, Taichung Hsien (TW)**

(74) Representative:  
**Blumbach, Kramer & Partner GbR**  
**Patentanwälte,**  
**Alexandrastrasse 5**  
**65187 Wiesbaden (DE)**

(71) Applicant: **MOLEX INCORPORATED**  
**Lisle Illinois 60532 (US)**

(54) **Arrowhead-shaped boardlock fastener for mounting a connector**

(57) A boardlock fastener for a connector includes an anchoring section and a mounting section. The anchoring section holds the fastener securely in a slot formed in a connector housing, while the mounting section is configured for insertion into a through-hole in a circuit board for mounting the connector against the circuit board. The mounting section of the fastener is generally arrowhead-shaped, having a central leg which projects downwardly relative to the connector body and two arms extending in a sloping manner upwardly, forming a V-shape. Each of the arms has a bend at an inter-

mediate location along the arm, forming a tine which is angled inwardly and upwardly, such that the two tines converge toward each other. During mounting of the connector, the mounting section of the fastener is inserted into the through-hole until the bends in the arms pass beyond a lower edge of the through-hole in the circuit board, opposite the housing of the connector. In this position, the tines are biased outwardly against the edge of the through-hole, securely holding the connector onto the circuit board. The resilient contact of the inwardly-angled tines facilitates the compensation of tolerance deviations while maintaining a secure mounting force.

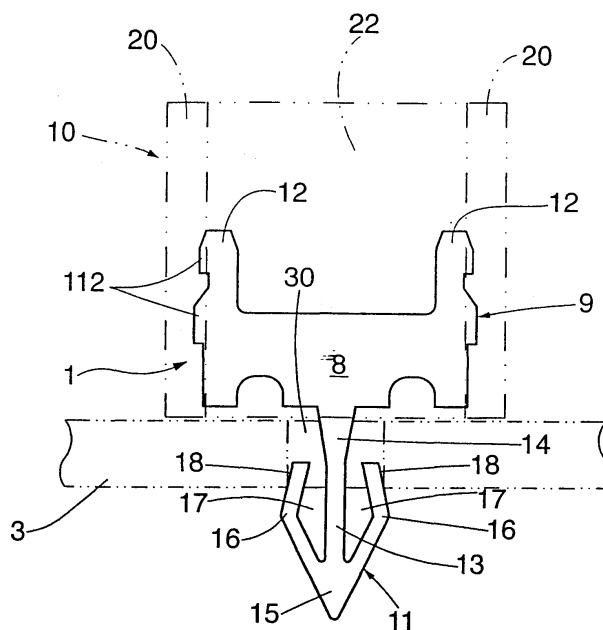

**FIG. 7**

## Description

### Background of the Invention

**[0001]** The present invention generally relates to the art of electrical connectors and, more particularly, to a device for anchoring a connector to a circuit board.

**[0002]** Circuit board connectors are widely used in electronic devices utilizing circuit boards. Typically, such a connector is used for mounting a secondary circuit board to a primary circuit board. The connector includes a housing which holds conductive terminals that connect respective electrical contacts on the circuit boards. A known type of circuit board connector is surface-mounted to the primary circuit board so that the terminals contact conductive pads on the primary circuit board. It is necessary to securely mount the connector to the primary circuit board in such a position for maintaining a proper connection to the secondary circuit board.

**[0003]** For mounting a connector to a circuit board, it is generally known to equip the connector with a plurality of boardlock fasteners. A conventional boardlock fastener has an anchoring section and a mounting section. The anchoring section is held within the housing, and the mounting section extends from the anchoring section to project from the housing. When the connector is assembled, the anchoring section is received within a slot in the housing. The conventional anchoring section has a plurality of barbs positioned to engage the housing for securing the boardlock fastener relative to the housing. The mounting section of the boardlock fastener is inserted into a through-hole in a circuit board. Known boardlock fasteners have a mounting section including a pair of generally parallel tines which project downwardly from the housing. When the connector is mounted to a circuit board by inserting the mounting section into the through hole, the tines resile outwardly and grip against the surface of the through hole for securing the connector onto the circuit board.

**[0004]** If the above-mentioned conventional boardlock fastener loosens from the circuit board, it could undesirably reduce the integrity of electrical contact or even cause the connector to become unmounted from the circuit board. Moreover, for conventional boardlock fastener designs, the permissible tolerance of the boardlock fastener relative to the through hole in the circuit board is small. If the assembling deviation substantially exceeds tolerance limits, the mounting section of the boardlock fastener will not firmly grip the through hole in the circuit board, and the connector will not be securely mounted.

### Summary Of The Invention

**[0005]** In order to provide improved mounting of a connector to a circuit board, the present invention provides a boardlock fastener that engages and grips the

through hole of a circuit board in an improved manner.

**[0006]** According to an embodiment of the invention, an electrical connector is provided for connecting conductive pads on a daughter circuit board to conductors on mother circuit board. The connector includes an insulative housing having side walls and a floor. An elongated groove is defined in the housing between the side walls for receiving a daughter circuit board therein. The connector includes a plurality of conductive terminals positioned along the groove to provide an electrical connection between the daughter and mother circuit boards in a known manner. The connector has a boardlock fastener for securing the connector to the mother circuit board. The fastener has an anchoring section and a generally arrowhead-shaped mounting section. The anchoring section is mounted into a fastener-receiving slot of the housing, and the mounting section projects downwardly from the housing. The mounting section includes a central leg for insertion into a through-hole in the mother circuit board and two arms upwardly diverging from the leg in a V-shape. Furthermore, each of the arms has a bend at an intermediate location along the arm, forming an inwardly-angled tine. The tines extend at an angle upwardly and inwardly so that the two tines converge toward each other. The tines are configured for abutting against walls of the through-hole in the circuit board to secure the connector to the board.

**[0007]** The arrowhead-shaped mounting section of the fastener can be easily inserted into a through-hole, causing the V-shaped arms to resiliently deflect inwardly. During mounting of the connector to a circuit board, the mounting section is inserted through the hole in the circuit board until the bends have passed beyond a lower edge of the circuit board. In this inserted position, the tines are held in biased contact against the bottom edge of the through-hole so that each of the tines applies an upward force component against the lower edge of the circuit board, resisting removal. Due to the inwardly-angled, converging configuration of the tines, the mounting section advantageously provides a good securing force to retain the housing securely against the circuit board. Moreover, the resilient contact of the tines advantageously compensates for tolerance deviations.

**[0008]** An advantage of the present invention is that it provides an improved boardlock fastener for anchoring a circuit board connector.

**[0009]** Another advantage of the present invention is that it provides a boardlock fastener which anchors a connector to a circuit board with an enhanced locking force.

**[0010]** A further advantage of the present invention is that it provides a boardlock fastener which allows larger manufacturing tolerances and assembly deviations.

**[0011]** Additional features are described in, and will be apparent from, the detailed description of the preferred embodiments, the claims, and from the drawings.

### Brief Description of the Drawings

**[0012]** FIG. 1 is a perspective view of a circuit board connector having a conventional boardlock fastener.

**[0013]** FIG. 2 is an end view of the boardlock fastener of the connector of FIG. 1, illustrating the surrounding connector housing in phantom lines.

**[0014]** FIG. 3 is a perspective view of the boardlock fastener of the conventional connector of FIG. 1.

**[0015]** FIG. 4 is a perspective view of a circuit board connector having a boardlock fastener constructed in accordance with teachings of the present invention.

**[0016]** FIG. 5 is a perspective view of the boardlock fastener of the connector of FIG. 4.

**[0017]** FIG. 6 is an end view of the connector of FIG. 4.

**[0018]** FIG. 7 is a cross-section view showing the boardlock fastener of the present invention assembled with a circuit board.

### Detailed Description of Presently Preferred Embodiments

**[0019]** Referring now to the drawings, wherein like numerals designate like components, FIG. 1 illustrates a conventional circuit board connector 5a. Such a connector may be used, for example, in a computer (not shown) for connecting a secondary circuit board to a primary circuit board. Generally, the conventional connector 5a of FIG. 1 includes an elongated housing 2a having at least one boardlock fastener 1a on the bottom thereof. As shown, the conventional connector 5a includes two fasteners 1a disposed at opposite ends of the housing 2a. The boardlock fasteners 1a can be clamped on a circuit board such that the connector can be mounted firmly on the circuit board.

**[0020]** FIGS. 2 and 3 illustrate the known type of boardlock fastener 1a in greater detail. The conventional boardlock fastener 1a has a U-shaped anchoring section 12a and a mounting section formed by a pair of parallel legs 13a on the upper and lower end thereof. The anchoring section 12a is embedded into the housing 2a whereby the boardlock fastener 1a is assembled on the housing 2a. A groove 14a is formed on the center of the mounting section 13a to provide resiliency to the mounting section 13a. The mounting section formed by the pair of generally parallel 13a is inserted into corresponding through-hole on the circuit board whereby the connector is fixed on the circuit board. Moreover, each of the legs 13a has a plurality of barbs 15a on an outwardly-directed side thereof to increase the locking strength between the legs 13a and the circuit board.

**[0021]** As mentioned, if the mounting section 13a of the conventional boardlock fastener 1a loosens from the circuit board, it could undesirably reduce the integrity of electrical contact or even cause the connector to become unmounted from the circuit board. Moreover, the permissible tolerance of the parallel legs 13a relative to the through hole in the circuit board is small. If the as-

sembling deviation substantially exceeds tolerance limits, the parallel legs 13a of the boardlock fastener 1a cannot grip the through hole in the circuit board with sufficient locking resistance, and the connector 5a will not be securely mounted.

**[0022]** Turning now to FIG. 4, a connector 5 is illustrated including a boardlock fastener 1 constructed in accordance with teachings of the present invention for mounting the connector 5 to a mother circuit board 3 (FIG. 7). The boardlock fastener 1 is described in greater detail in connection with FIGS. 5-7. Generally, the connector 5, as illustrated in FIG. 4, includes an elongated insulative housing 2 having a pair of longitudinal sidewalls 20. An elongated groove 22 is defined between the sidewalls 20 for receiving a secondary circuit board (not shown), in a manner generally known in the art.

**[0023]** For conductively connecting the mother and daughter circuit boards, the connector 5 further includes a plurality of conductive terminals 24. The housing 2 is shaped to have a plurality of terminal cavities 26 which respectively receive the terminals in a seated manner. Each of the terminals 24 has a contact portion in a respective terminal cavity 26 which extends in the groove 22 for contacting a conductive pad (not shown) on the daughter circuit board in a generally known manner. Opposite the contact portion, each of the terminals 24 also has a tail portion 124 which extends out of the housing 2 for engaging a respective conductor (not shown) on the mother circuit board 3 (FIG. 7).

**[0024]** Referring to FIGS. 5-7, the boardlock fastener 1 has a U-shaped anchoring section 9 for anchoring the fastener 1 to the housing 2. The anchoring section 9 is inserted into a slot 50 (FIG. 6) in the bottom of the housing 2. In an embodiment, the anchoring section 9 is formed by a generally transverse base 8 and a pair of beams 12 which respectively project upwardly from opposite ends of the base 8. Each of the upwardly projecting beams 12 has one or more barbs 112 extending in a laterally outward manner for engaging and gripping the housing 2, as illustrated in FIG. 7, thereby anchoring the fastener 1 securely relative to the housing.

**[0025]** For securely mounting the connector 5 to the mother circuit board 3 (FIG. 7), the boardlock fastener 1 also includes a generally arrowhead-shaped mounting section 11 which projects downwardly from the housing 2. The mounting section 11 has a central leg 13 which extends downwardly from the base 8. In an embodiment, the central leg 13 has a widened proximal end 14 that joins the base 8, enhancing the inserting strength and rigidity of the mounting section 11. The central leg 13 has a distal tip 15 located distally relative to the base 8 and opposite the proximal end 14 of the central leg 13. The tip 15 is preferably generally tapered in shape for easy guidance during insertion of the mounting section 14 into a circuit board.

**[0026]** The mounting section 11 further includes two arms 16 which extend outwardly away from the central

leg and upwardly toward the base 8, forming a V shape. In an embodiment, the central leg 13 has a widened end 14 which joins the base. By the connection end 14, the mounting section 11 is integrally formed with the anchoring section 10. Moreover, the central leg 13 is perpendicular to the bottom surface of the anchoring section 10. As illustrated in FIGS. 5-7, a freely-extending upper segment of each of the arms 16 has an inwardly-angled tine 18. A clearance 17 is defined between each of the arms and the central leg 13 to allow flexible and resilient movement of the arms 16.

**[0027]** For mounting the connector 5, as shown in FIG. 7, the mounting section 11 is inserted into a through-hole 30 disposed in the circuit board 3. As the mounting section 11 of the boardlock fastener 1 is inserted through the through-hole 30, the arms 16 resiliently flex inwardly. The dimensions of the mounting section 11 are configured so that upon full insertion of the mounting section, at which point the connector housing 2 rests upon the circuit board 3, the bends in the arms 16 pass just beyond a lower surface of the board so that the inwardly-angled upper tines 18 contact the lower edge of the through hole 30. The tines 18 resile outwardly against the circuit board 3 to pulled upwardly through the through hole 30. Due to the inward angle of the tines 18, the tines apply an upward force component against the circuit board 3, thereby fastening the connector 5 to the circuit board 3. The resilient flexibility of the arms 16 compensate for deviations in manufacturing tolerances to allow secure fastening in the described manner.

**[0028]** It is also contemplated that upper ends of the upper tines 18 may actually catch or abut against a lower surface of relatively sufficiently thin circuit boards 3.

**[0029]** Although the present invention has been described with reference to the preferred embodiment thereof, it will be understood that the invention is not limited to the specific features of the described embodiment. Various substitutions and modifications to the present invention will be apparent to those skilled in the art. Such substitutions and modifications may be made without departing from the spirit and scope of the invention. Accordingly, the appended claims are intended to encompass such substitutions and modifications.

## Claims

1. An electrical connector (5) for connecting conductive pads on a daughter circuit board to conductors on mother circuit board comprising: an insulative housing (10) having side walls (20) and a floor defining an elongated groove (22) for receiving the daughter circuit board therein, said housing defining terminal cavities along the elongated groove, and a fastener-receiving slot (50) in the floor;

a plurality of terminals (24) mounted in said terminal cavities, each of the terminals having a

contact portion extending into the elongated groove for engaging a respective conductive pad on the daughter circuit board and a tail portion (124) extending out of the housing (10) for engaging a respective conductor on the mother circuit board (3);

a fastener (1) having an anchoring section (9) mounted in the fastener-receiving slot (50) in the housing and a mounting section extending downwardly, said mounting section including a central leg (13) for insertion into a through-hole (30) in the mother circuit board, two arms (16) upwardly diverging from said leg for supporting a tine (18) on an end of each arm, said tines upwardly converging from said arms for abutting against walls of the through-hole in the circuit board to secure said connector to the board.

2. The electrical connector of claim 1, wherein the fastener (1) includes a base (8) which supports the anchoring section (9) and from which the mounting section (11) descends.

3. The electrical connector of claim 2, wherein the anchoring section (9) comprises a pair of spaced beams (12) extending upwardly from ends of said base, said beams (12) including a barb (112) for skiving into walls of the slot (50).

4. The electrical connector of claim 3 wherein said beams (12) and said base (8) define a recess that coincides with said elongated groove (22) in said housing.

5. The electrical connector of claim 1, wherein the tines (18) abut against the lower edge of the through-hole (30) in the mother circuit board (3).

6. The electrical connector of claim 1, wherein said central leg (13) and said arms (16) meet at a vertex (15) defining an arrow head shape.

7. A fastener (1) for fastening an electrical connector (5) to a circuit board (3), said fastener comprising:

a base (8) having two ends;  
an anchoring section (12) extending upwardly from said base for securing said fastener in a slot (50) in a housing (10) of the electrical connector;

a mounting section (11) extending downwardly from said base, said mounting section (11) including a central leg (13) for insertion into a through-hole (30) in the circuit board, two arms (16) upwardly diverging from said leg for supporting a tine (18) on an end of each arm, said tines upwardly converging from said arms for

abutting against walls of the through-hole in the circuit board to secure said connector to the board.

8. The electrical connector of claim 7, wherein the anchoring section (9) comprises a pair of spaced beams (12) extending upwardly from the ends of said base (8), said beams each including at least one barb (112) for skiving into walls of the slot (50). 5
9. The electrical connector of claim 8, wherein said beams (12) and said base (8) define a recess that coincides with said elongated groove (22) in said housing (10). 10
10. The electrical connector of claim 7, wherein the tines (18) abut against a lower edge of the through-hole (30) in the circuit board (3).
11. The electrical connector of claim 7, wherein said central leg (13), and said arms (16) meet at a vertex (15) defining an arrow head shape. 20
12. An electrical connector for connecting conductors on an electrical component to conductors on a circuit board (3): 25

an insulative housing (10) defining a receptacle (22) for receiving the electrical component therein, said housing defining terminal cavities about the receptacle, and a fastener-receiving slot (50) in the housing; 30

terminals (24) mounted in said terminal cavities having a contact portion extending into the receptacle for engaging a respective conductor on the electrical component and a tail portion (124) extending out of the housing for engaging a respective conductor on the circuit board; 35

a fastener (1) having an anchoring section (9) mounted in the slot in the housing and a mounting section (11) extending downwardly, said mounting section including a central leg (13) for insertion into a through-hole (30) in the circuit board, two arms (16) upwardly diverging from said leg (13) for supporting a tine (18) on an end of each arm, said tines upwardly converging from said arms for abutting against walls of the through-hole in the circuit board to secure said component to the board. 40

45

13. The electrical connector of claim 12, wherein the fastener (1) includes a base (8) which supports the anchoring section (9) and from which the mounting section (11) descends. 50
14. The electrical connector of claim 13, wherein the anchoring section (9) comprises a pair of spaced beams (12) extending upwardly from ends of said 55

base (8), said beams including at least one barb (112) for skiving into walls of the slot (50).

15. The electrical connector of claim 14, wherein said beams (12) and said base (8) define a recess that coincides with said elongated groove (22) in said housing (10).
16. The electrical connector of claim 12, wherein the tines (18) abut against the lower edge of the through-hole (30) in the circuit board (3).
17. The electrical connector of claim 12, wherein said central leg (13), and said arms (16) meet at a vertex (15) defining an arrow head shape.

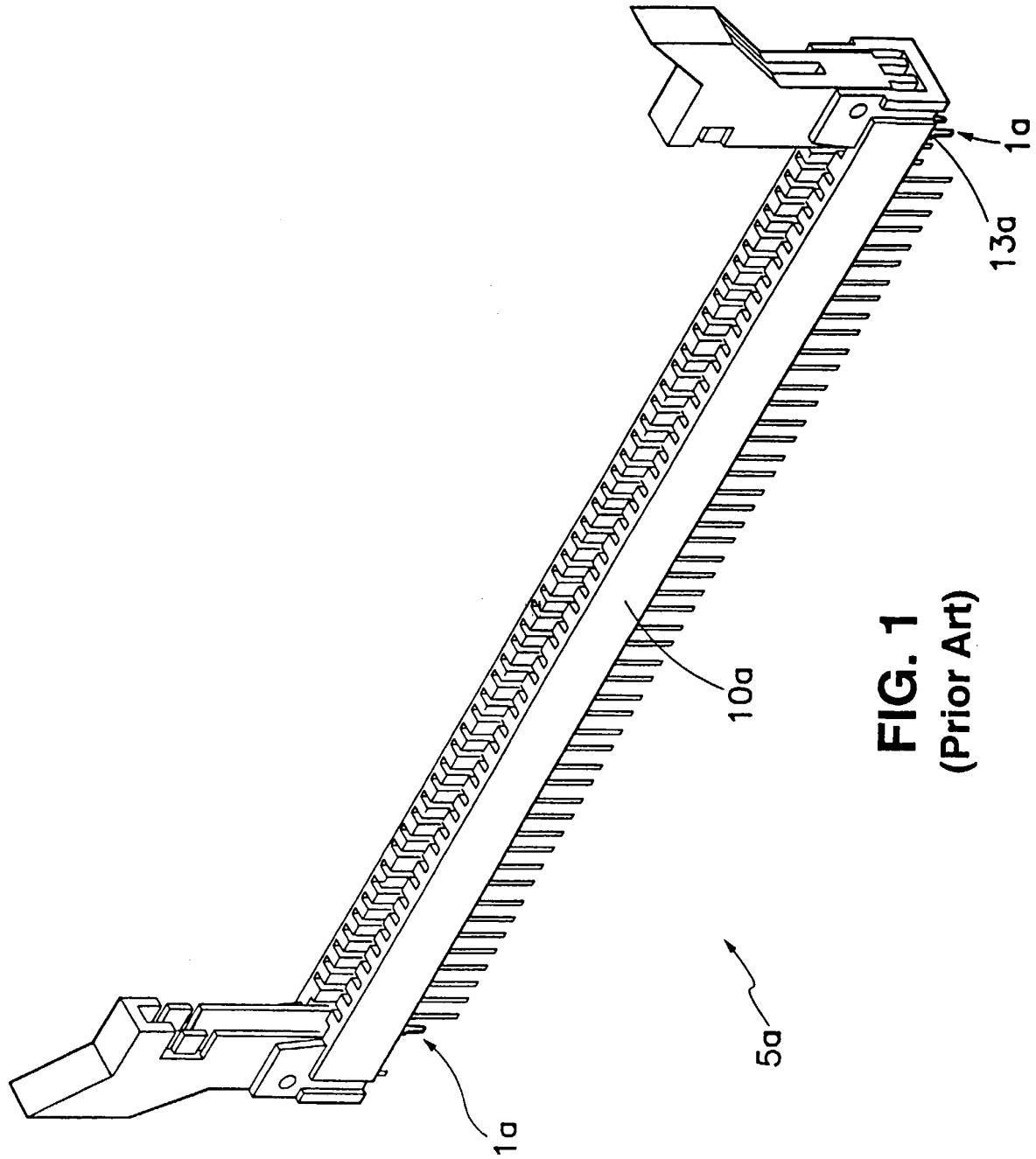

**FIG. 1**  
(Prior Art)

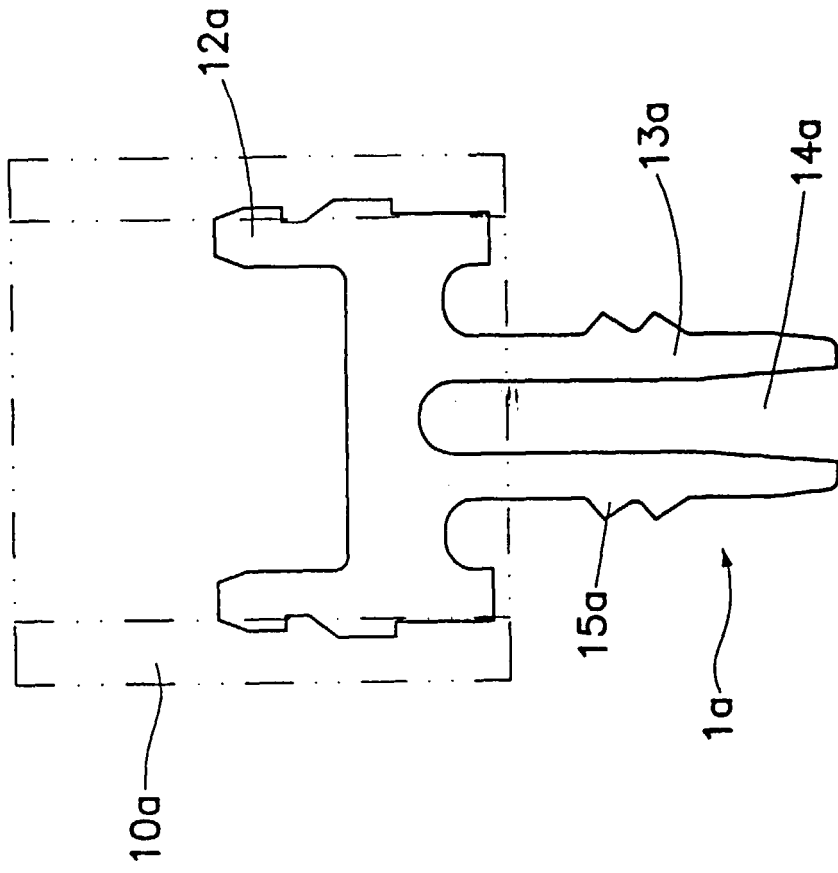

**FIG. 2**  
**(Prior Art)**

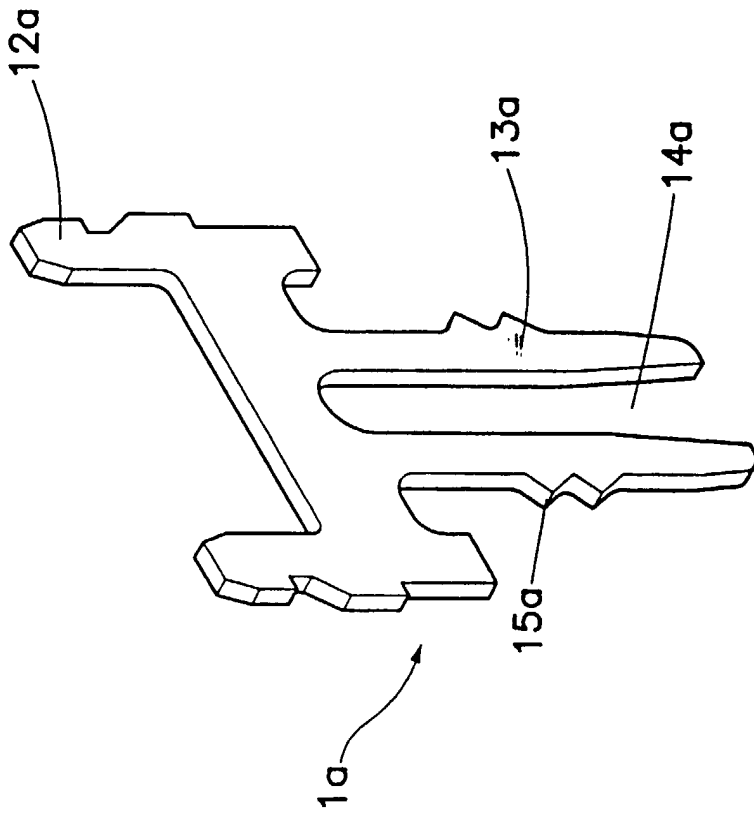

**FIG. 3**  
(Prior Art)

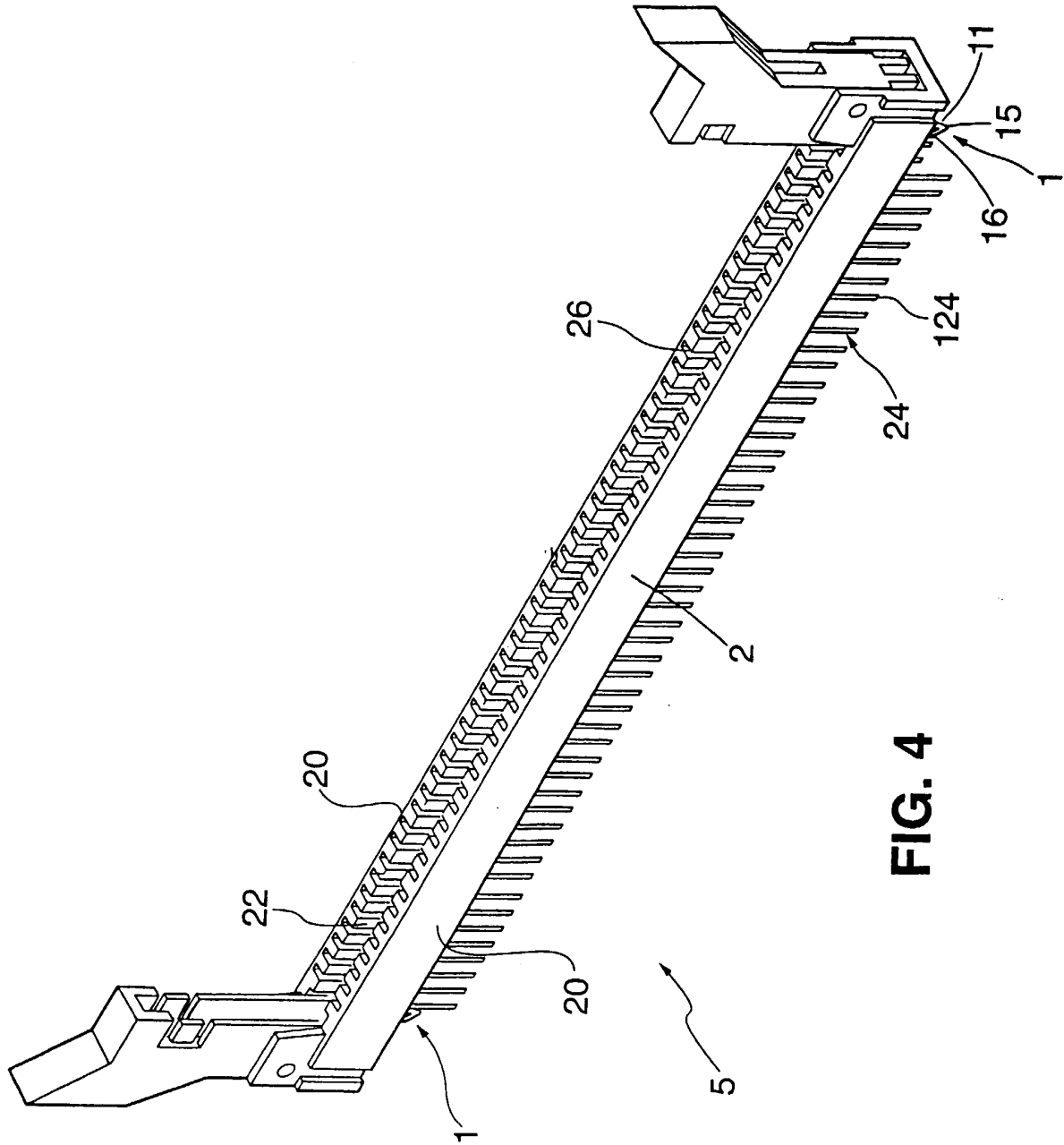

**FIG. 4**

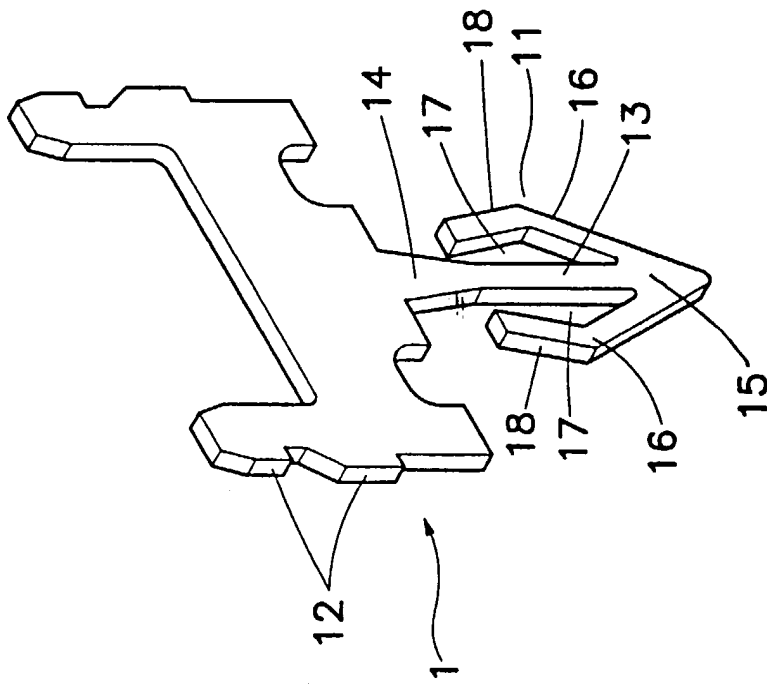

**FIG. 5**

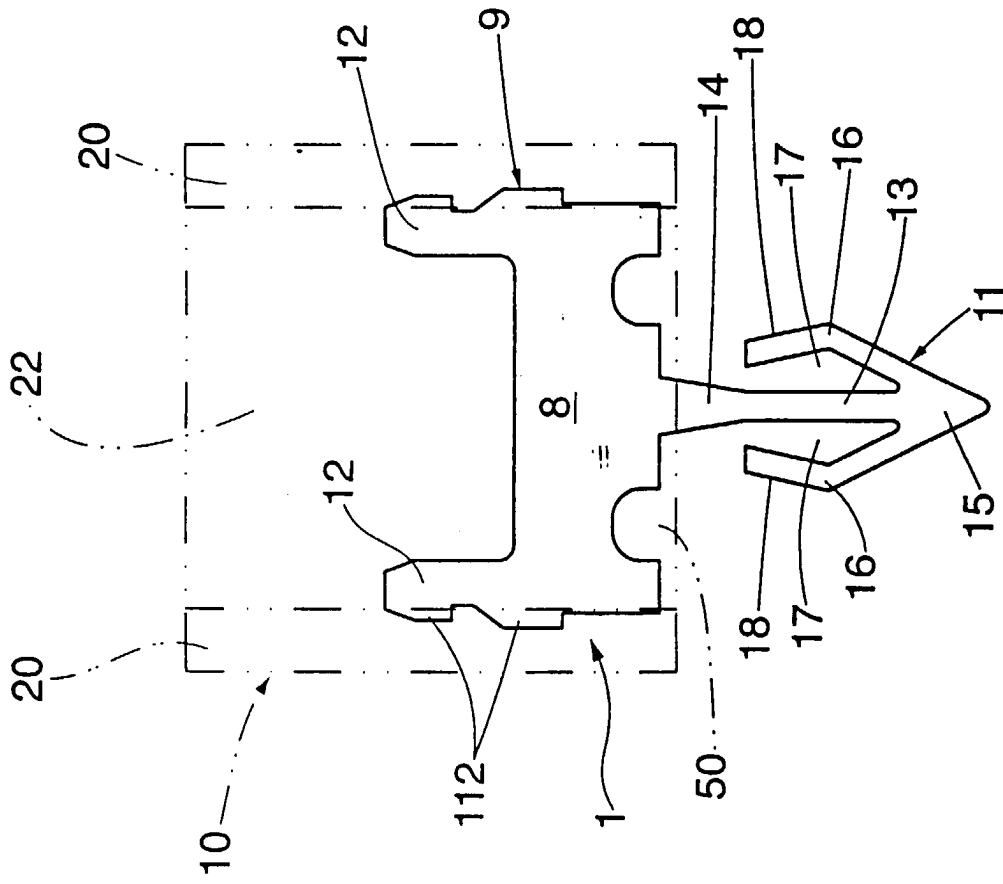

**FIG. 6**

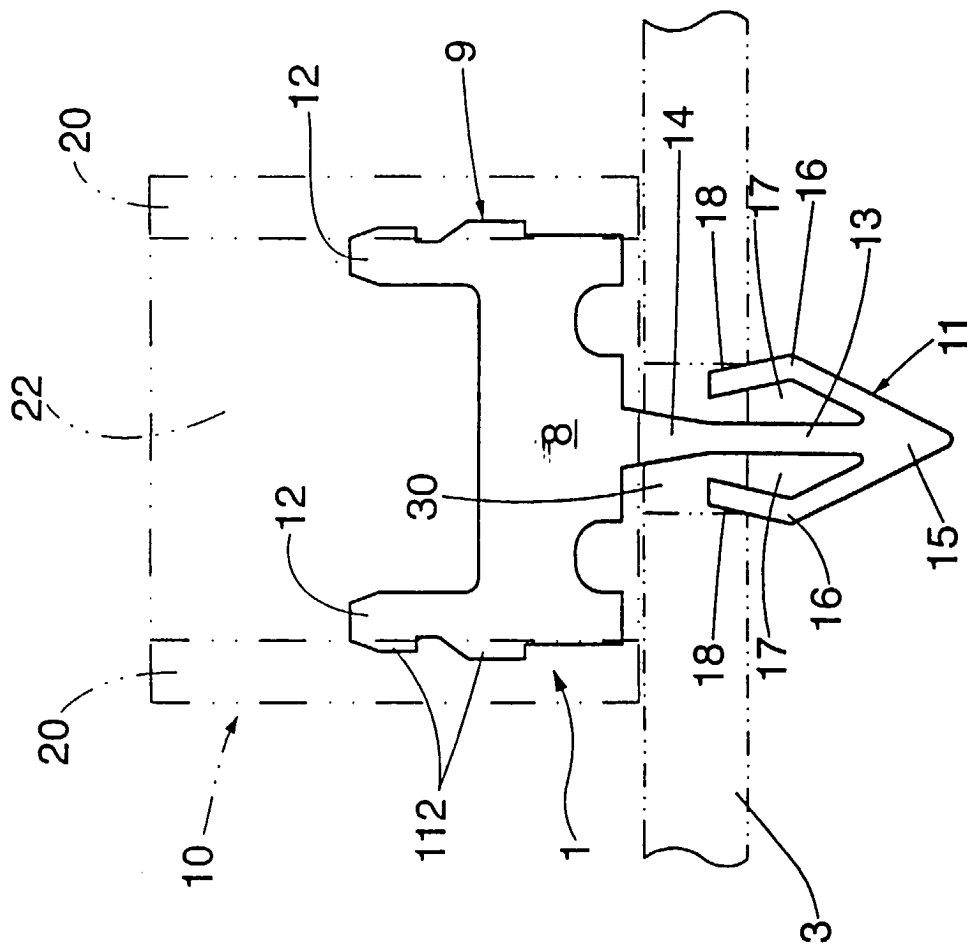

**FIG. 7**



European Patent  
Office

EUROPEAN SEARCH REPORT

Application Number  
EP 99 11 7228

DOCUMENTS CONSIDERED TO BE RELEVANT			
Category	Citation of document with indication, where appropriate, of relevant passages	Relevant to claim	CLASSIFICATION OF THE APPLICATION (Int.Cl.7)
A	DE 298 23 013 U (ADELS KG) 25 February 1999 (1999-02-25) * page 8, paragraph 3 *	1,7,12	H01R12/20
A	EP 0 718 932 A (WHITAKER CORP) 26 June 1996 (1996-06-26) * column 5, line 58 - column 6, line 21 *	1,7,12	
A	US 4 766 652 A (SUGIURA HARUYUKI) 30 August 1988 (1988-08-30) * column 3, line 32 - line 42 *	1,7,12	
			TECHNICAL FIELDS SEARCHED (Int.Cl.7)
			H01R H05K
The present search report has been drawn up for all claims			
Place of search <b>THE HAGUE</b>		Date of completion of the search <b>3 February 2000</b>	Examiner <b>Demo1, S</b>
<b>CATEGORY OF CITED DOCUMENTS</b> X : particularly relevant if taken alone Y : particularly relevant if combined with another document of the same category A : technological background O : non-written disclosure P : intermediate document		T : theory or principle underlying the invention E : earlier patent document, but published on, or after the filing date D : document cited in the application L : document cited for other reasons ..... & : member of the same patent family, corresponding document	

EPO FORM 1503 03.02 (P04C01)

ANNEX TO THE EUROPEAN SEARCH REPORT  
ON EUROPEAN PATENT APPLICATION NO.

EP 99 11 7228

This annex lists the patent family members relating to the patent documents cited in the above-mentioned European search report. The members are as contained in the European Patent Office EDP file on  
The European Patent Office is in no way liable for these particulars which are merely given for the purpose of information.

03-02-2000

Patent document cited in search report	Publication date	Patent family member(s)	Publication date
DE 29823013 U	25-02-1999	NONE	
EP 0718932 A	26-06-1996	US 5632649 A CN 1135668 A JP 8241770 A	27-05-1997 13-11-1996 17-09-1996
US 4766652 A	30-08-1988	JP 1660944 C JP 3025643 B JP 62233509 A CH 672662 A DE 3635866 A DE 8628122 U FR 2596822 A GB 2188669 A, B SE 467120 B SE 8701351 A	19-05-1992 08-04-1991 13-10-1987 15-12-1989 17-01-1991 12-02-1987 09-10-1987 07-10-1987 25-05-1992 03-10-1987