



(12) **EUROPEAN PATENT APPLICATION**

(43) Date of publication:
16.05.2001 Bulletin 2001/20

(51) Int Cl.7: **E05B 65/20, E05B 1/00**

(21) Application number: **00124655.2**

(22) Date of filing: **10.11.2000**

(84) Designated Contracting States:
**AT BE CH CY DE DK ES FI FR GB GR IE IT LI LU
MC NL PT SE TR**
Designated Extension States:
AL LT LV MK RO SI

(72) Inventor: **Agostini, Astorre**
10091 Alpignano (IT)

(74) Representative: **Cerbaro, Elena, Dr. et al**
STUDIO TORTA S.r.l.,
Via Viotti, 9
10121 Torino (IT)

(30) Priority: **12.11.1999 IT TO990976**

(71) Applicant: **Valeo Sicurezza Abitacolo S.p.A.**
10026 Santena (IT)

(54) **Vehicle door handle**

(57) A handle (1) for a vehicle door (2) has a supporting structure (10) fittable to the door (2), and a control lever (15) having an elongated grip portion (16) and which is movable, with respect to the supporting structure (10), between a rest position and a control position controlling a lock on the door (2); the control lever (15)

is connected to the supporting structure (10) by a guide and slide assembly (37) to enable the grip portion (16) to move between the rest position and the control position along a conical surface (S) having a generating line (D) substantially parallel to the elongated grip portion (16).

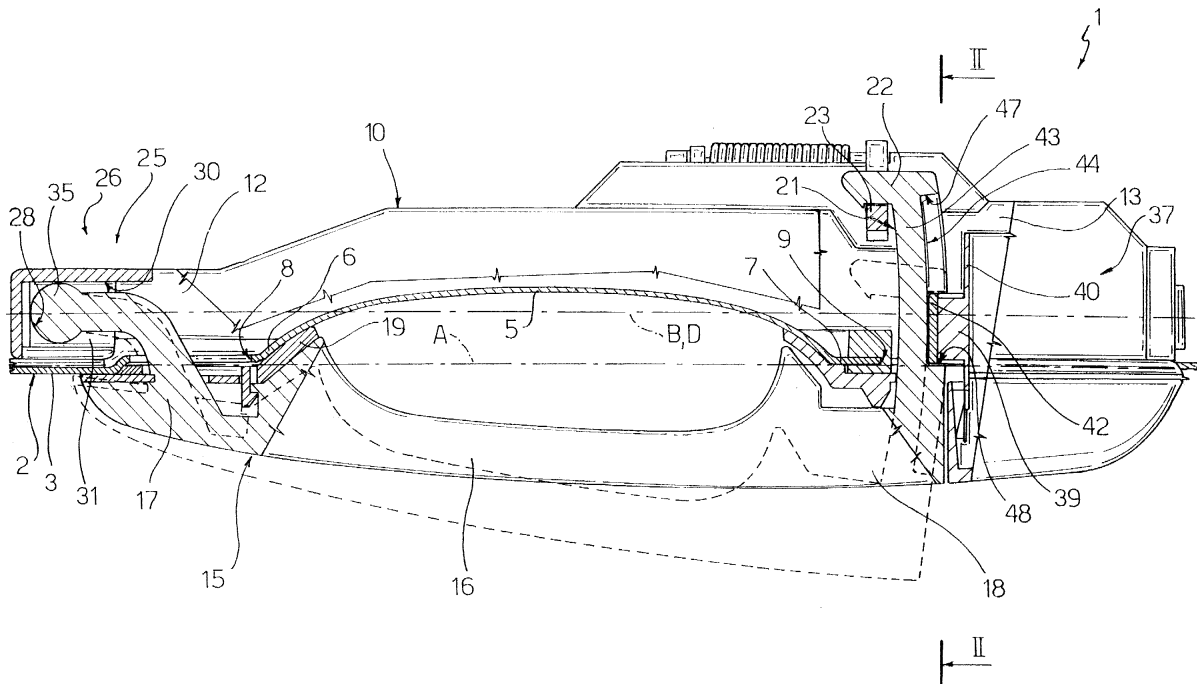

Fig.1

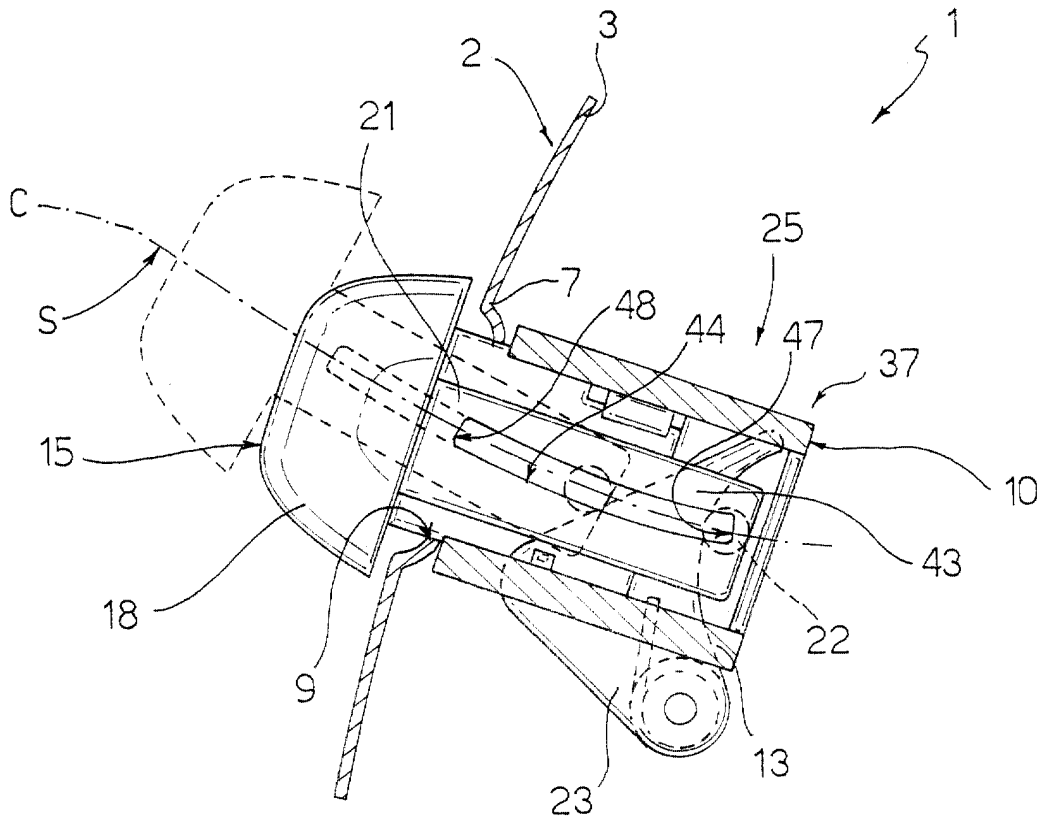

Fig.2

Description

[0001] The present invention relates to a vehicle door handle, and in particular to a handle of the type comprising a structure fittable integrally to a door of the vehicle, and a control lever in turn comprising an elongated intermediate outer grip portion facing the body of the door. The control lever also comprises an end portion hinged to the structure to enable the control lever to rotate, about a normally vertical hinge axis, between a rest position and a release position to release a lock on the door.

[0002] When, for construction reasons, the control lever is located relatively low down on the vehicle door, known handles of the type described above make it extremely awkward for the user to both release the lock and open the door.

[0003] That is, to release the lock, the user's arm must be held perfectly straight downwards to grip the grip portion, and force must be exerted by the user to rotate the grip portion in a substantially horizontal plane. Once the lock is released, the user must remain in a bent position, and, to open the door, exert additional force, the useful component of which is that in the horizontal plane, while the other components are transmitted to the hinges.

[0004] The force required to both release the lock and open the door is therefore not only considerable but also applied in a bent and, in any case, unnatural position.

[0005] It is an object of the present invention to provide a vehicle door handle designed to eliminate the aforementioned drawbacks.

[0006] According to the present invention, there is provided a handle for a vehicle door; the handle comprising a supporting structure fittable to said door; a control lever comprising an elongated grip portion gripped manually, in use, by a user to release a lock on said door; and connecting means for connecting said control lever to said supporting structure to enable the control lever to move, with respect to said supporting structure, between a rest position and a control position controlling said lock; characterized in that said connecting means comprise guide means for enabling at least said elongated grip portion to move between said rest position and said control position along a conical surface having a generating line substantially parallel to said elongated grip portion.

[0007] A non-limiting embodiment of the invention will be described by way of example with reference to the accompanying drawings, in which:

Figure 1 shows a partly sectioned view, with parts removed for clarity, of a preferred embodiment of the handle according to the present invention and fitted to a vehicle door;

Figure 2 shows a section, with parts removed for clarity, along line II-II in Figure 1;

Figure 3 shows a partly sectioned front view of a detail of the Figure 1 handle;

Figures 4 and 5 show the same views as in Figures 2 and 3 respectively, and of a variation of the Figure 2 and 3 handle.

[0008] Number 1 in Figure 1 indicates a handle for a vehicle door 2 (shown partly). Door 2 comprises an outer body 3 in turn comprising a concave intermediate portion 5, and two portions 6 and 7 having respective openings 8 and 9 and located on opposite sides of portion 5 in a direction A parallel, in use, to a horizontal longitudinal direction of the vehicle.

[0009] With reference to the accompanying drawings, handle 1 extends in a direction B parallel to direction A, and comprises a supporting structure 10, which is fitted to body 3, inside door 2, is connected integrally to door 2 in known manner not described in detail, and comprises two hollow end portions 12 and 13 adjacent to portions 6 and 7 respectively.

[0010] Handle 1 also comprises a lever 15 outside door 2 and in turn comprising an elongated intermediate grip portion 16, which is gripped by a user to move lever 15 between a rest position (shown by the continuous line in Figures 1, 2 and 4) and a control position (shown by the dash line in Figures 1, 2 and 4) to release a lock (not shown) on door 2. Grip portion 16 extends facing portion 5 and in a direction substantially parallel to direction B when in the rest position.

[0011] With particular reference to Figure 1, lever 15 also comprises two end portions 17 and 18 located on opposite sides of grip portion 16. Portion 17 extends through portions 6 and 12, and supports a seal 19 which mates with portion 6 to seal opening 8. Portion 18, on the other hand, carries an integral arm 21 extending through portions 7 and 13 and terminating with an appendix 22 connected to a known transmission lever 23 carried by structure 10 and for releasing the lock on door 2.

[0012] Lever 15 is connected to structure 10 by means of a connecting assembly 25.

[0013] With reference to Figure 1, assembly 25 comprises a spherical joint device 26 in turn comprising a dead retaining seat 28 formed in portion 12, parallel to direction B, and having an inlet 30 facing portion 13; and a spherical head 35 integral with the end of portion 17 of lever 15, and which engages seat 28 to enable lever 15 to rotate with respect to structure 10 about a center of rotation.

[0014] As shown in Figures 1, 2 and 3, connecting assembly 25 also comprises a guide device 37 interposed between arm 21 and portion 13 of structure 10 to enable grip portion 16 to move between the rest and control positions along a conical surface S.

[0015] Conical surface S has as a vertex the center of rotation of spherical joint device 26, and is defined by a generating line D through the center of rotation and parallel to grip portion 16, and by a curved directrix, the trace of which in a plane perpendicular to direction B is indicated C in Figure 2 and extends, in the example de-

scribed, along an arc of a circle.

[0016] Device 37 is defined by a guide and slide assembly comprising a guide 39 defined by a fixed portion forming part of a member 40, which is connected, in known manner not shown, to portion 13 on the opposite side of arm 21 with respect to grip portion 16, and houses a key-operated lock (not shown) of handle 1. Guide 39 is located in a fixed position facing arm 21, is covered with a layer 42 of self-lubricating material, is elongated and prismatic in shape, and has a V-shaped cross section (Figure 3).

[0017] With reference in particular to Figure 2, the guide and slide assembly also comprises a slide 43, which forms part of arm 21 and in turn comprises an elongated groove 44 having a V-shaped cross section complementary to that of layer 42.

[0018] Groove 44 is connected in sliding manner to guide 39 by the interposition of layer 42, and extends along a single curved path coincident with the curved directrix having trace C to guide grip portion 16 along conical surface S.

[0019] As shown in Figures 1 and 2, groove 44 is defined by two surfaces 47 and 48 extending crosswise to the curved path on opposite sides of guide 39, and which cooperate with and come to rest against guide 39 to define the limit control and rest positions of lever 15 respectively.

[0020] In the Figure 4 and 5 variation, the guide and slide assembly comprises a guide 50 in turn comprising two supporting members 51, which are connected integrally to portion 13 in fixed positions on opposite sides of arm 21 in a plane perpendicular to direction B. Each supporting member 51 supports a pair of rollers 53, which rotate about respective axes 54 substantially parallel to direction B, and are spaced apart in a direction parallel to arm 21.

[0021] The guide and slide assembly also comprises a slide 55 also forming part of arm 21 and in turn comprising two opposite curved lateral surfaces 56 bounding arm 21 and which define two tracks substantially parallel to direction B and to trace C, and each mating in rolling manner with a respective pair of rollers 53.

[0022] Still with reference to Figures 4 and 5, arm 21 carries an integral appendix 58 projecting towards member 40; member 40 carries a stop member 60, which is located in an intermediate position between appendix 58 and portion 18 of lever 15 and is positioned facing and detached from arm 21; and appendix 58 comes to rest against stop member 60 to define the limit control position of lever 15.

[0023] To assemble the handle, structure 10 is first fitted to door 2, and lever 15 is then connected to structure 10. In the case of the Figure 4 and 5 variation, arm 21 is inserted through portions 7 and 13; surfaces 56 are fitted contacting rollers 53 connected beforehand to portion 13 by means of supporting members 51; and, finally, member 40 is connected to structure 10. In the Figure 2 and 3 embodiment, on the other hand, arm 21 is simply

inserted through portions 7 and 13, and guide 39 fitted to groove 44 to connect member 40 to portion 13.

[0024] In actual use, to release the lock on door 2 and open door 2 itself, the user grips and pulls grip portion 16 outwards by exerting a force substantially parallel to conical surface S and therefore having a vertical upward component. Once rotated, grip portion 16 rotates from the rest to the control position along conical surface S, and, once the lock is released by means of transmission lever 23, the user continues exerting on grip portion 16 a pulling force directed substantially along a tangent to conical surface S to open door 2.

[0025] When located relatively low down on door 2, handle 1 as described and illustrated enables the user to open door 2 easily and with relatively little effort as compared with known solutions.

[0026] Guide device 37, in fact, provides for guiding grip portion 16, with respect to structure 10, along conical surface S, so that the user can open door 2 by exerting, in use, a force having a vertical upward component and a component extending in a horizontal plane crosswise to the door. When lever 15 is pulled towards the user, the user therefore exerts a force whose useful component is not only directed in a horizontal plane, and whose vertical component is not transmitted entirely to the hinges, as in known solutions.

[0027] After releasing the lock by moving lever 15 to the control position, the user, to open door 2, continues the same movement performed to rotate lever 15, thus performing one continuous, relatively effortless movement, during which, the user tends to straighten up from the bent position in which lever 15 is gripped.

[0028] Spherical joint device 26 enables lever 15 to travel along any path defined by guide device 37.

[0029] Clearly, changes may be made to handle 1 as described herein without, however, departing from the scope of the present invention.

[0030] In particular, spherical head 35 may engage retaining seat 28 with sufficient clearance parallel to direction B to eliminate any jamming and reduce the effort required to operate handle 1, and so, for example, make up for any errors in the manufacture or assembly of handle 1, or any deformation caused by variations in temperature.

[0031] Devices 26 and 37 may differ from those described and illustrated in the accompanying drawings, and slide 43, 55 may be defined by a portion separate from arm 21.

[0032] The trace of the curved directrix in a plane perpendicular to direction B may be shaped differently from trace C shown; and the curved path of device 37 may be parallel to, as opposed to lying on, conical surface S.

55 Claims

1. A handle (1) for a vehicle door (2); the handle (1) comprising a supporting structure (10) fittable to

said door (2); a control lever (15) comprising an elongated grip portion (16) gripped manually, in use, by a user to release a lock on said door (2); and connecting means (25) for connecting said control lever (15) to said supporting structure (10) to enable the control lever (15) to move, with respect to said supporting structure (10), between a rest position and a control position controlling said lock; characterized in that said connecting means (25) comprise guide means (37) for enabling at least said elongated grip portion (16) to move between said rest position and said control position along a conical surface (S) having a generating line (D) substantially parallel to said elongated grip portion (16).

2. A handle as claimed in Claim 1, characterized in that said connecting means (25) comprise substantially spherical joint means (26).

3. A handle as claimed in Claim 2, characterized in that said joint means (26) comprise a retaining seat (28) formed in said supporting structure (10); and a spherical head (35) carried by said control lever (15) and engaging said retaining seat (28).

4. A handle as claimed in Claim 2 or 3, characterized in that said control lever (15) comprises a first (17) and a second (18) end portion located on opposite sides of said elongated grip portion (16); said first end portion (17) carrying part (35) of said spherical joint means (26); and said second end portion (18) carrying part (43; 55) of said guide means (37).

5. A handle as claimed in any one of the foregoing Claims, characterized in that said guide means (37) comprise a guide and slide assembly (37) in turn comprising a guide (39; 50) carried by said supporting structure (10) in a fixed position, and a slide (43; 55) carried by said control lever (15) and connected to said guide (39; 50); at least one of said slide (43; 55) and said guide (39; 50) extending along a single curved path (C) parallel to said conical surface (S).

6. A handle as claimed in Claim 5, characterized in that said control lever (15) carries an arm (21) extending through said supporting structure (10) to release said lock; said slide (43; 55) forming part of said arm (21).

7. A handle as claimed in Claim 6, characterized in that said arm (21) comprises a groove (44) parallel to said curved path (C) and defining part of said guide means (37).

8. A handle as claimed in any one of Claims 5 to 7, characterized in that said guide (39; 50) and said slide (43; 55) are connected to each other in sliding manner by the interposition of a block (42) of self-

lubricating material.

9. A handle as claimed in any one of Claims 5 to 7, characterized in that at least one (50) of said guide (39; 50) and said slide (43; 55) comprises at least one rolling-contact body (53) connected in rolling manner to the other (55) of said guide (39; 50) and said slide (43; 55).

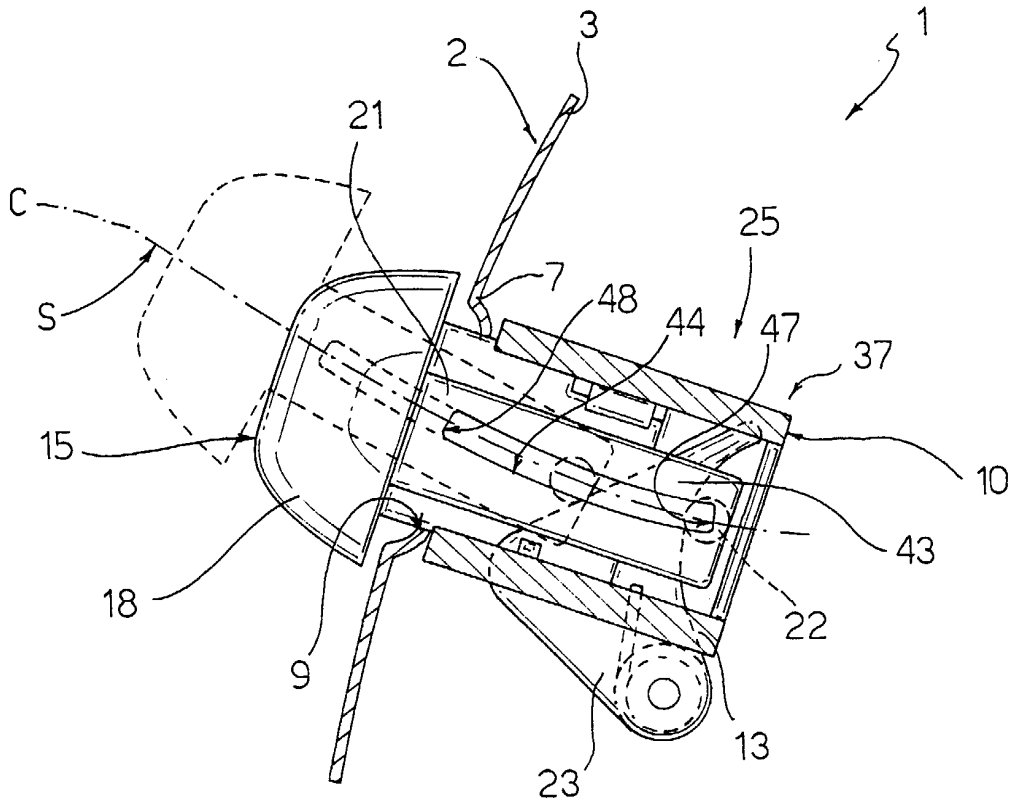

Fig.2

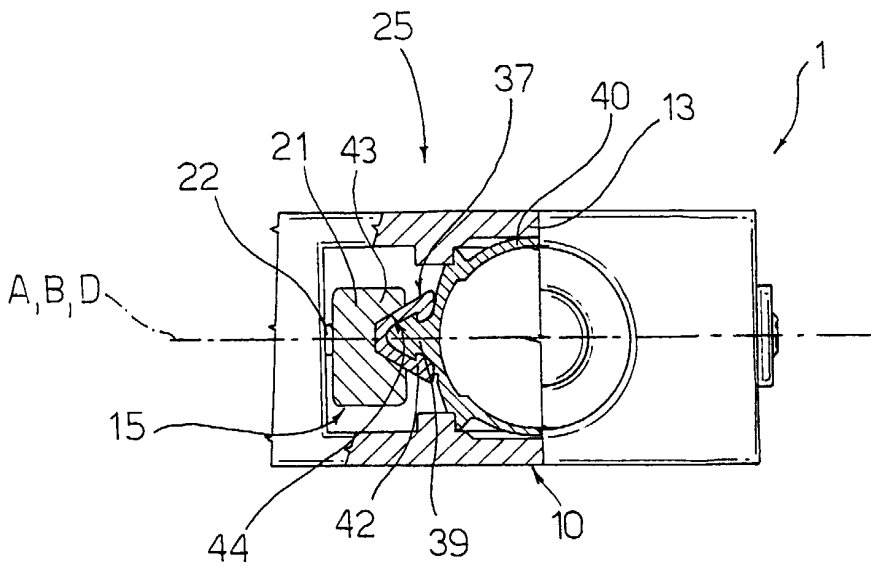

Fig.3

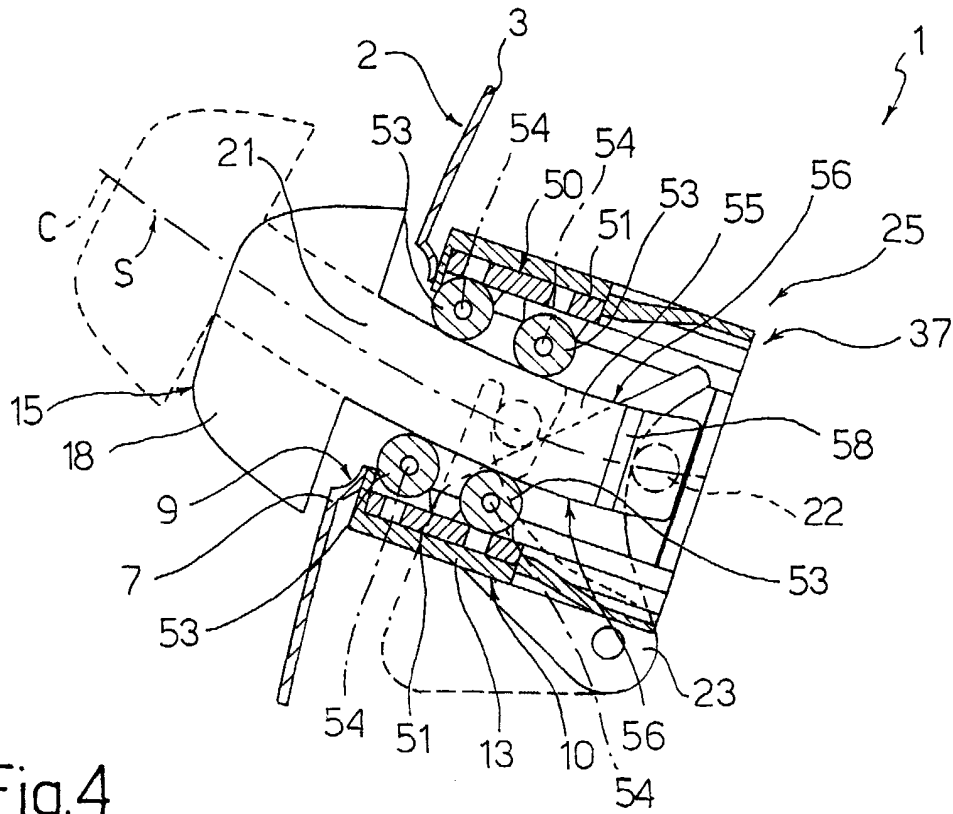

Fig.4

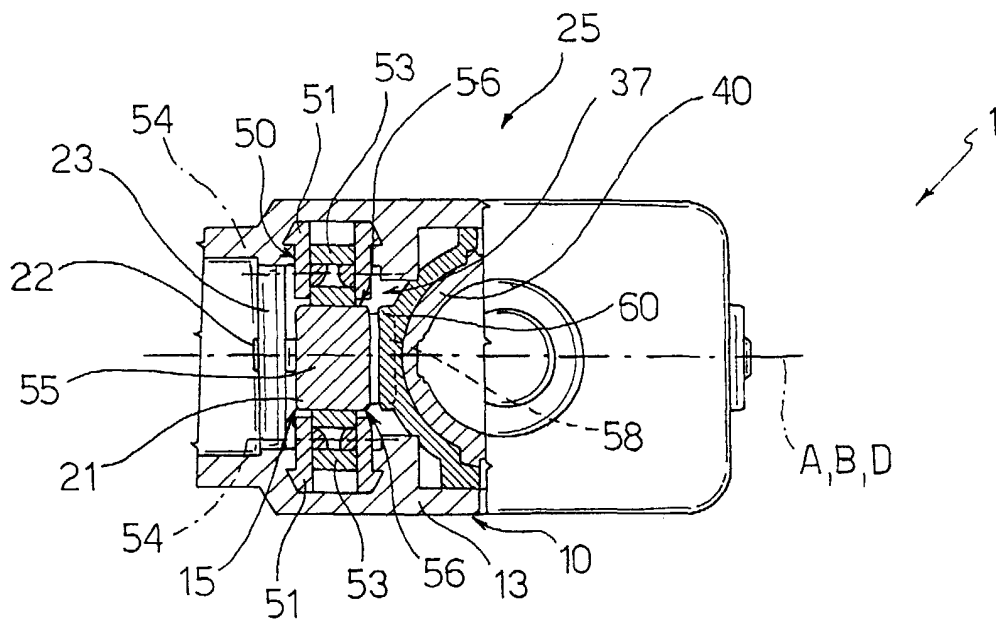

Fig.5



European Patent
Office

EUROPEAN SEARCH REPORT

Application Number
EP 00 12 4655

DOCUMENTS CONSIDERED TO BE RELEVANT			
Category	Citation of document with indication, where appropriate, of relevant passages	Relevant to claim	CLASSIFICATION OF THE APPLICATION (Int.Cl.7)
X	US 2 278 534 A (J. W. DICKASON) 7 April 1942 (1942-04-07)	1, 2, 6	E05B65/20 E05B1/00
A	* figures * ---	3-5	
X	US 2 131 033 A (J. W. BARRINGTON ET AL) 27 September 1938 (1938-09-27)	1	
A	* figures * ---	4, 6	
X	US 5 970 757 A (RAMSAUER) 26 October 1999 (1999-10-26)	1-3	
A	* figures * -----	4, 6	
			TECHNICAL FIELDS SEARCHED (Int.Cl.7)
			E05B
The present search report has been drawn up for all claims			
Place of search		Date of completion of the search	Examiner
MUNICH		1 March 2001	Vacca, R
CATEGORY OF CITED DOCUMENTS X : particularly relevant if taken alone Y : particularly relevant if combined with another document of the same category A : technological background O : non-written disclosure P : intermediate document T : theory or principle underlying the invention E : earlier patent document, but published on, or after the filing date D : document cited in the application L : document cited for other reasons & : member of the same patent family, corresponding document			

EPO FORM 1503 03 82 (P04C01)

**ANNEX TO THE EUROPEAN SEARCH REPORT
ON EUROPEAN PATENT APPLICATION NO.**

EP 00 12 4655

This annex lists the patent family members relating to the patent documents cited in the above-mentioned European search report. The members are as contained in the European Patent Office EDP file on
The European Patent Office is in no way liable for these particulars which are merely given for the purpose of information.

01-03-2001

Patent document cited in search report	Publication date	Patent family member(s)	Publication date
US 2278534 A	07-04-1942	NONE	
US 2131033 A	27-09-1938	NONE	
US 5970757 A	26-10-1999	DE 9217546 U	19-05-1993
		DE 9305893 U	17-06-1993
		DE 9315055 U	09-02-1995
		DE 29715560 U	24-12-1998
		AT 139819 T	15-07-1996
		BR 9307730 A	31-08-1999
		DE 59303091 D	01-08-1996
		DE 59304148 D	14-11-1996
		WO 9415049 A	07-07-1994
		WO 9415050 A	07-07-1994
		EP 0677131 A	18-10-1995
		EP 0675994 A	11-10-1995
		JP 3025306 B	27-03-2000
		JP 8507839 T	20-08-1996
		US 5722269 A	03-03-1998
		US 5685181 A	11-11-1997

EPC FORM P0459

For more details about this annex : see Official Journal of the European Patent Office, No. 12/82