



(12) **EUROPEAN PATENT APPLICATION**

(88) Date of publication A3:  
**13.11.2002 Bulletin 2002/46**

(51) Int Cl.7: **F04B 27/10**

(43) Date of publication A2:  
**25.07.2001 Bulletin 2001/30**

(21) Application number: **00127703.7**

(22) Date of filing: **18.12.2000**

(84) Designated Contracting States:  
**AT BE CH CY DE DK ES FI FR GB GR IE IT LI LU  
MC NL PT SE TR**  
Designated Extension States:  
**AL LT LV MK RO SI**

- Yokomachi, Naoya,  
KK Toyoda Jidoshokki Seisakusho  
Kariya-shi, Aichi-ken (JP)
- Murakami, Kazuo,  
KK Toyoda Jidoshokki Seisakusho  
Kariya-shi, Aichi-ken (JP)
- Nakane, Yoshiyuki,  
KK Toyoda Jidoshokki Seisakusho  
Kariya-shi, Aichi-ken (JP)

(30) Priority: **19.01.2000 JP 2000009908**

(71) Applicant: **Kabushiki Kaisha Toyota Jidoshokki  
Kariya-shi, Aichi-ken (JP)**

(74) Representative:  
**Leson, Thomas Johannes Alois, Dipl.-Ing.  
Tiedtke-Bühling-Kinne & Partner GbR,  
TBK-Patent,  
Bavariaring 4  
80336 München (DE)**

(72) Inventors:  
• Fujii, Toshiro,  
KK Toyoda Jidoshokki Seisakusho  
Kariya-shi, Aichi-ken (JP)

(54) **Swash plate type compressor**

(57) The electrically driven swash plate compressor consists of an electric motor (21) in the motor chamber (15) and a swash plate (26) with the stationary cylinder block (13) in the crank chamber (16). The swash plate is rotated by the drive shaft (17), whereby noise and vibration in the direction perpendicular to the drive shaft are reduced. The swash plate is supported on the drive

shaft by the supporting member (22). The rotating supporting member (22) has an inclined surface (22A) with respect to the axis of the drive shaft for supporting the swash plate by means of the thrust bearing (23) and the radial roller bearing (25) mounted on the perpendicular shaft support (22B). The roller bearing (25) has a small frictional resistance, which results in a reduction of mechanical losses.

**Fig. 1**

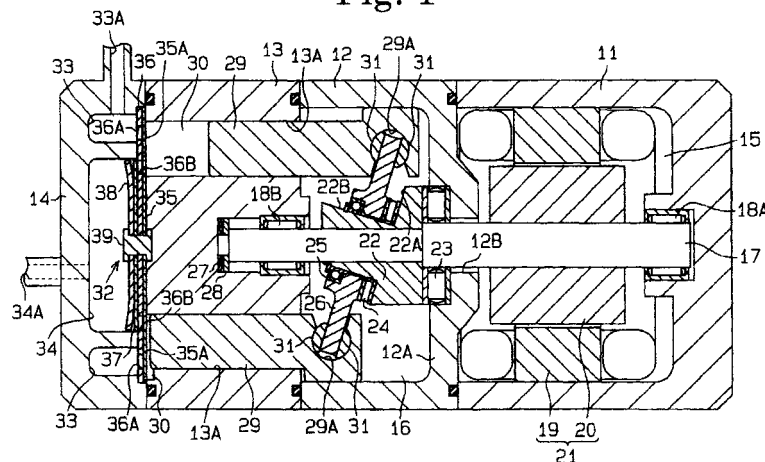



European Patent Office

EUROPEAN SEARCH REPORT

Application Number  
EP 00 12 7703

DOCUMENTS CONSIDERED TO BE RELEVANT			
Category	Citation of document with indication, where appropriate, of relevant passages	Relevant to claim	CLASSIFICATION OF THE APPLICATION (Int.Cl.7)
X	US 4 586 874 A (HIRAGA MASA HARU ET AL) 6 May 1986 (1986-05-06) * abstract; figure *	1	F04B27/10
Y	* column 1, line 62-66 * * column 2, line 37 - column 3, line 57 * ---	2,4	
Y	US 3 934 967 A (GANNAWAY EDWIN L) 27 January 1976 (1976-01-27)	2	
A	* column 5, line 27-31 * ---	3,5	
Y	US 5 813 314 A (UEDA YASUNORI ET AL) 29 September 1998 (1998-09-29) * column 2, line 38-47; figure 5 * ---	4	
X	GB 2 327 717 A (LUK FAHRZEUG HYDRAULIK) 3 February 1999 (1999-02-03) * figure 1 * -----	1	
The present search report has been drawn up for all claims			TECHNICAL FIELDS SEARCHED (Int.Cl.7)
			F04B
Place of search	Date of completion of the search	Examiner	
MUNICH	18 September 2002	Richmond, R	
CATEGORY OF CITED DOCUMENTS		T : theory or principle underlying the invention E : earlier patent document, but published on, or after the filing date D : document cited in the application L : document cited for other reasons ..... & : member of the same patent family, corresponding document	
X : particularly relevant if taken alone Y : particularly relevant if combined with another document of the same category A : technological background O : non-written disclosure P : intermediate document			

EPO FORM 1503 03/82 (P04/C01)

**ANNEX TO THE EUROPEAN SEARCH REPORT  
ON EUROPEAN PATENT APPLICATION NO.**

EP 00 12 7703

This annex lists the patent family members relating to the patent documents cited in the above-mentioned European search report.  
The members are as contained in the European Patent Office EDP file on  
The European Patent Office is in no way liable for these particulars which are merely given for the purpose of information.

18-09-2002

Patent document cited in search report		Publication date	Patent family member(s)	Publication date
US 4586874	A	06-05-1986	JP 1588922 C	19-11-1990
			JP 2014996 B	10-04-1990
			JP 60135680 A	19-07-1985
			AU 574023 B2	23-06-1988
			AU 3708184 A	04-07-1985
			CA 1235402 A1	19-04-1988
			DE 3478238 D1	22-06-1989
			EP 0172970 A2	05-03-1986
			IN 163156 A1	20-08-1988
			KR 9004604 B1	30-06-1990
			MX 161825 A	28-12-1990
US 3934967	A	27-01-1976	NONE	
US 5813314	A	29-09-1998	JP 2937040 B2	23-08-1999
			JP 8144944 A	04-06-1996
			CN 1132314 A	02-10-1996
			DE 19542945 A1	30-05-1996
			KR 167371 B1	20-03-1999
GB 2327717	A	03-02-1999	DE 19807923 A1	12-11-1998
			DE 19807691 A1	15-10-1998
			DE 19807947 A1	05-11-1998
			DE 19808251 A1	10-09-1998
			FR 2763102 A1	13-11-1998
			FR 2760258 A1	04-09-1998
			FR 2762876 A1	06-11-1998
			FR 2784142 A1	07-04-2000
			GB 2358891 A ,B	08-08-2001
			GB 2328252 A ,B	17-02-1999
			GB 2329224 A ,B	17-03-1999
			IT MI980421 A1	03-09-1998
			IT MI980422 A1	03-09-1998
			IT MI980423 A1	03-09-1998
			JP 10306773 A	17-11-1998
			JP 11030181 A	02-02-1999
			JP 10306774 A	17-11-1998
US 6250204 B1	26-06-2001			
US 6056517 A	02-05-2000			
US 6092996 A	25-07-2000			
US 6213733 B1	10-04-2001			

EPO FORM P0459

For more details about this annex : see Official Journal of the European Patent Office, No. 12/82