



(12) **EUROPEAN PATENT APPLICATION**

(43) Date of publication:
08.08.2001 Bulletin 2001/32

(51) Int Cl.7: **H01R 13/629, H01R 9/05**

(21) Application number: **00102417.3**

(22) Date of filing: **04.02.2000**

(84) Designated Contracting States:
**AT BE CH CY DE DK ES FI FR GB GR IE IT LI LU
 MC NL PT SE**
 Designated Extension States:
AL LT LV MK RO SI

(72) Inventor: **Henningsen, Jimmy Ciesla
 4700 Naestved (DK)**

(74) Representative: **Roerboel, Leif et al
 Budde, Schou & Ostenfeld A/S,
 Vester Sogade 10
 1601 Copenhagen V (DK)**

(71) Applicant: **Cabel-Con A/S
 DK-4760 Vordingborg (DK)**

(54) **One piece connector**

(57) Connector for a coaxial cable preferably for high frequencies which connector comprises a center terminal to be connected to the inner conductor of the coaxial cable and a main body to be directly connected to the outer conductor of the cable, where said main body is provided with a number of longitudinal slits making it possible to monitor the introduction of the outer

conductor into the main body and where the connector is furthermore provided with a support means placed inside said main body such that the insertion of said outer conductor into the main body simultaneously has the effect of establishing a proper and reliable electrical contact between said center terminal of the connector and said inner conductor of the coaxial cable.

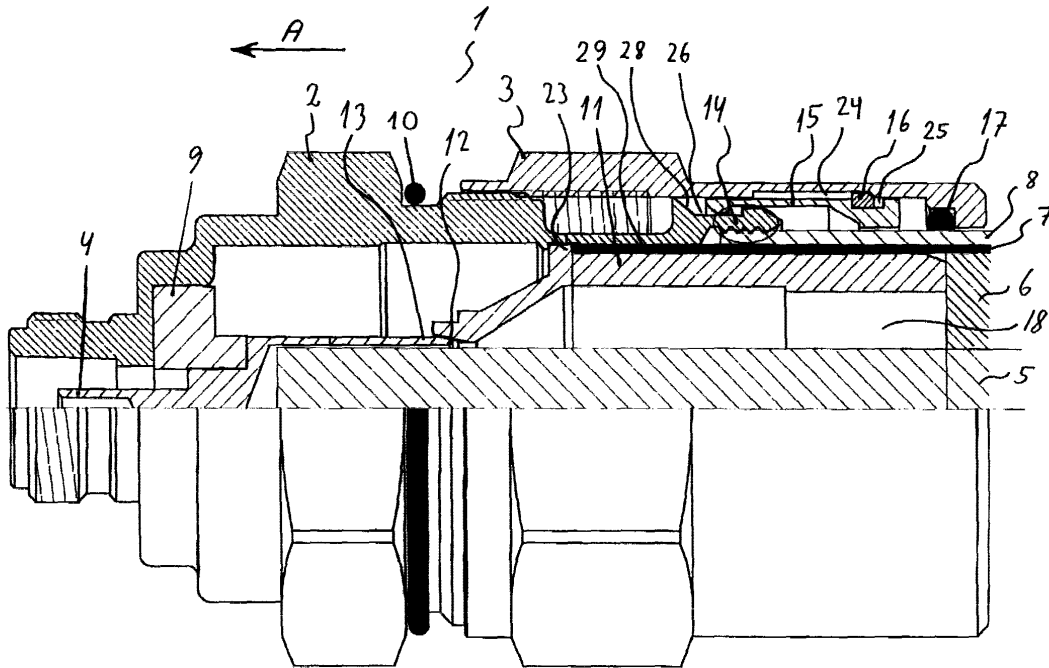

Fig.1

DescriptionTECHNICAL FIELD

[0001] The present invention relates generally to cable connectors and more particularly to connectors for coaxial cables for high frequencies, such as used in transmitter masts and the like, as set forth in the preamble of claim 1 and 2.

BACKGROUND ART

[0002] Many prior art coaxial cable connectors suffer from a number of disadvantages from the point of view of ease of handling and ease of obtaining a correct and reliable positioning of the connector on the cable, for example with respect to attaining the optimal degree of insertion of the cable into the connector. Furthermore many prior art connectors consist of a number of parts which can be separated from each other, which may cause problems for instance when the connector is being mounted on a cable in a high transmitter mast etc. Due to the size and weight of some of the connectors used in such places, the dropping of parts of the connector from an elevated position may even present hazards to people working at the foot of the mast. Furthermore, some prior art connectors require tools to finish the mounting of the connector on the cable, for instance to provide a firm attachment of the center terminal of the connector to the inner conductor of the cable. Furthermore, many prior art connectors do not provide for a simple visual indication of a correct placement of the connector on the cable. Finally the fact that many prior art connectors consist of a large number of components is a disadvantage from a manufacturing point of view, both regarding the production set-up in the factory and regarding quality control procedures.

DISCLOSURE OF THE INVENTION

[0003] It is the object of the present invention to provide a cable connector primarily for a coaxial cable as mentioned above, which connector solves the above problems and overcomes said disadvantages associated with many prior art connectors, and more particularly to provide a connector, which both facilitates handling of the connector during the mounting hereof on a cable and at the same time provides for an optimal electrical connection of the connector to the cable, and an optimal mechanical attachment hereto. The handling of the connector is partly being facilitated by the fact that the connector according to the invention makes it possible to establish the connection between the center terminal of the connector and the inner conductor of the cable without using fastening tools and partly by the fact that the connector is delivered as a one-piece connector, so that various parts hereof may not be dropped during mounting of the connector on the cable. Furthermore, an op-

5 timal placement of the connector on the cable is ascertained by providing indicator means on the connector, making it possible from outside to ascertain that a correct placement of the connector on the cable is in fact obtained. Furthermore a reduction of intermodulation distortion on the electrical signal after passage through the connector is according to the invention being obtained through a reduction of the number of separate components interacting electrically (and mechanically) with each other in the connector, and hence a reduction of the number of electrical contact surfaces inserted between the outer conductor of the coaxial cable and those parts of the connector, which shall be connected to the outer conductor. In the embodiment of the invention described in the detailed description of the invention thus only 2 contact surfaces between the outer conductor and the main body of the connector is present, which is the minimum number of contact surfaces possible. The reduction of the number of said contact surfaces furthermore reduces the overall risk of contamination between contact surfaces in the connector and hence improves its overall reliability as well as provides for a more simple and effective production set-up of the connector. Finally, an optimal electrical connection (i.e. minimal electrical contact resistance) is obtained with a connector according to the invention in that a mechanical cleaning of the contact surface of the outer conductor of the cable is obtained during mounting of the connector on the cable.

[0004] These and other objects are achieved with a connector in accordance with the invention as set forth in the characterising clause of claim 1, 2 and 5. Preferred embodiments of the connector according to the invention are set forth in the remaining dependent claims.

[0005] The connector according to the present invention comprises (contrary to many prior art connectors) one tubular main body, which can receive said coaxial cable and provide direct electrical contact between the outer conductor of the coaxial cable and said tubular main body without any intermediary means between said tubular main body and said outer conductor, and which main body is provided with a center terminal, which center terminal is to be electrically and mechanically connected to the inner conductor of said coaxial cable, and a tubular bushing which can be attached to a rear portion of said main body, for instance by means of suitable threads provided on the outer surface of the main body and on a frontal portion of said bushing, and where at least said main body is to be electrically and mechanically connected to the outer conductor of said coaxial cable. The rear portion of said main body is characterised in that it comprises a number of longitudinal slits cut through the wall of the rear portion of the main body, so that this portion is able to be compressed and/or expanded radially to ensure correct and reliable direct electrical contact between said rear portion of the main body and the outer conductor of the cable, and in that it is furthermore provided with means on a part of the inner

surface of said rear portion, for instance in the form of threads to be brought into engagement with the jacket of said coaxial cable during the mounting of the connector on the cable, said mounting being performed for instance by screwing the connector unto the cable, and thus displacing the connector longitudinally relative to the cable. Due to the presence of said longitudinal slits through the wall of the rear portion of the main body, it is possible visually to monitor the displacement of the outer conductor of the cable inside said main body and thereby to ascertain the correct relative longitudinal placement of the connector on the cable. Furthermore, the connector comprises a tubular support means, which is substantial rigid in the radial direction, positioned within said main body, so that said support means can be displaced longitudinally a certain distance within said main body, and where the outer diameter of said support means is slightly less than the inner diameter of a part of said rear portion of said main body, so that the gab thereby formed between the rear portion of said main body and said support means can accommodate the outer conductor of said cable. Said support means comprises a radially outwardly projecting circumferential collar, against which the end of the outer conductor of the coaxial cable is being pressed, when said main body is being mounted on said cable, for instance by screwing the connector onto the cable, thereby resulting in a longitudinal displacement of said support means in the direction towards the center terminal of the connector. Furthermore, said support means at the end hereof facing said center terminal of the connector is provided with a connecting portion connecting said support means with the outer surface of a rear portion of said center terminal, said rear portion of the center terminal being provided with a number of longitudinal slits through the wall of said rear portion of the center terminal, so that a longitudinal displacement of said support means in the direction towards said center terminal by means of said connecting portion causes said rear portion of the center terminal to be radially compressed against the outer surface of the inner conductor of said coaxial cable and by this compression providing a firm electrical and mechanical contact between said center terminal and said inner conductor.

[0006] Thus, for instance by screwing said main body unto a suitably prepared end of a coaxial cable, an electrically and mechanically reliable attachment and connection is achieved between the center terminal of the connector and the inner conductor of the coaxial cable.

[0007] According to the invention, said bushing can as previously mentioned be displaced longitudinally relative to said main body of the connector. According to the invention, retainer means are provided between said main body and said bushing, which retainer means provide for the possibility to displace the bushing on the main body over a certain limited distance in the longitudinal direction, but which retainer means also make a complete separation of said bushing from said main

body impossible, once the connector has initially been assembled. Thus, according to the invention it is not possible incidentally to drop the various parts hereof, for instance during mounting of the connector on a cable.

[0008] When the connector is properly positioned on the cable, the outer conductor of the cable is being retained in the gab formed between the inner circumferential surface of said rear portion of said main body and the outer circumferential surface of said support means by virtue of the fact that said rear portion due to said longitudinal slits provided therein is able to expand and/or compress in the radial direction, whereas said outer circumferential surface of said support means is radially non-compressible, said rear portion thereby exerting a radially inwardly directed force against the outer conductor of the cable. Thus, when the connector is properly positioned on the cable, electrical contact between said outer conductor and said main body is obtained. When as a final step of the mounting process of the connector on the end of the coaxial cable said bushing is screwed as much as possible longitudinally over the main body, the end of said retaining means placed between the rear portion of the main body and the bushing which is facing the center terminal engages an outwardly directed circumferential protrusion provided on the outer surface of the rear portion of the main body, with the effect that said rear portion is being pressed radially towards the longitudinal axis of the connector and thereby increases the contact pressure between the outer circumferential surface of the outer conductor and the inner circumferential surface of the rear portion of the main body. This increased contact pressure ensures an even better and more reliable electrical and mechanical connection and attachment between the outer conductor of the cable and the main body of the connector.

[0009] The relative displacement between the main body and the outer conductor caused by said screwing of the main body unto the prepared end of the cable during mounting hereof has the further advantageous effect that due to the frictional movement between the main body and the outer conductor, dirt and remains of insulating materials adhering to the outer conductor of the cable, which dirt and remains of insulating material incidentally has not been properly removed during the preparation of the cable, will be removed during mounting of the connector on the cable, because the inner edges of said longitudinal slits cut in the rear portion of the main body will scrape off dirt and remains of insulation, said dirt and remains of insulation being able hereafter to accumulate in said longitudinal slits. This feature further improves the performance and reliability of the connector according to the invention.

BRIEF DESCRIPTION OF THE DRAWINGS

[0010] The invention will now be described by way of example and with reference to the accompanying drawings, in which:

Figure 1 is a longitudinal partly sectional view of a preferred embodiment of the connector according to the invention;

Figure 2 shows at the top (a) a longitudinal view of the center terminal and below (b) a longitudinal view of the main body of the connector with visual indicator means in the form of two longitudinally extending narrow slits through a rear portion of the wall of the main body; and

Figure 3 shows the end of a cable prepared for receiving the connector.

DETAILED DESCRIPTION OF THE INVENTION

[0011] Hereafter a detailed description of a preferred embodiment of the connector according to the present invention will follow.

[0012] Prior to mounting, the end of the cable is prepared by exposing a suitable length of the outer conductor 7 by cutting off a corresponding length of the jacket 8. Furthermore, the inner conductor 5 is exposed in such a manner that the inner conductor 5 extends longitudinally beyond the end of the outer conductor 7. Finally, a suitable length of the insulating material 6 disposed between the inner conductor 5 and the outer conductor 7 is removed, leaving a cavity 18 between said conductors. A prepared cable could for instance look somewhat like the one shown in figure 3. After preparation of the cable, the connector is mounted hereon as described in the following with reference to figure 1 and 2.

[0013] Prior to the application of the connector on the end of the cable, the bushing 3 of the connector is displaced longitudinally as far as possible relative to the main body 2 of the connector towards the rear end of the connector, i.e. to the right on the drawings. It is not possible to remove the bushing 3 of the connector entirely from the main body 2 of the connector due to the presence of the retaining means 15, 16, 24, 25, 26 between the main body 2 of the connector and the bushing 3, the function of which retaining means will be described in detail in the following. This displacement leaves a part of the longitudinal slits 21 through the wall of the main body free for inspection from outside, so that the outer conductor 7 of the cable during insertion of the connector on the end of the cable can be viewed through said slits 21. The connector is pushed over the end of the cable until the point where the end of the jacket reaches the thread 14 provided on the inner wall of the rear portion 22 of the main body 2. Thereafter the connector is displaced further in the longitudinal direction over the end of the cable by screwing the main body 2 of the connector onto the jacket 8 with the aid of said thread 14. This further displacement of the connector relative to the end of the cable can be monitored by visual inspection of the outer conductor 7 through said slits 21 in the wall of the main body 2. It is thus possible by visual inspection to ascertain the correct longitudinal position of the connector on the end of the cable.

[0014] When the connector 1 is screwed onto the cable with the aid of the thread 14 provided on the inner wall of the back portion of the main body 2 of the connector, the support means 11 is forced to move along the axis of the connector in the direction indicated by the arrow A, because the end of the outer conductor 7 presses against the collar 23 on the support means 11. This longitudinal movement of the support means 11 results in that the inclined center surface 12 of support means 11 is pressed in the direction of arrow A over the rear portion 13 of the central terminal 4 of the connector 1, which portion may be similarly inclined, whereby said rear portion 13 due to the presence herein of the narrow slits 20 is being pressed radially against the inner conductor 5 of the cable. Thus, screwing the connector onto the jacket 8 of the cable simultaneously provides a firm connection between the inner conductor 5 of the cable and the center terminal 4 of the connector without the application of fastening tools.

[0015] Regarding the function of the retaining means 15, 16, 24, 25, 26 between the main body 2 of the connector and the bushing 3, these means have the combined effect that once assembled by the manufacturer, it will not be possible to separate the main body 2 and the bushing 3 from each other. Furthermore, due to the dimensions of the various details of said retaining means 15, 16, 24, 25, 26, it is possible to displace the bushing 3 relative to the main body 2 to such an extent that it becomes possible to see said longitudinal slits 21 cut through the wall of the rear portion of the main body 2 and hence as mentioned to visually monitor the insertion of the outer conductor 7 of the cable into the connector 1. The retaining means comprise a connecting annulus 15 slidably positioned between the rear portion of the main body 2 and the bushing 3, one end of said connection annulus 15 being free to move longitudinally in an annular recess 26 provided in the rear portion of the main body 2, and the other end of said connection annulus 15 being provided with a circumferential recess 25 containing a retainer ring 16, which retainer ring 16 is able to move freely longitudinally in a circular recess 24 cut in the inner wall of the bushing 3.

After properly fastening of the connector 1 onto the end of the cable by means of said thread 14, the bushing 3 is screwed onto the main body 2 by means of the thread 27 for final connection between the main body 2 and the bushing 3. The connector is finally provided with two sealing joints, for instance in the form of O-rings 10, 17, ensuring a hermetically sealed placement of the bushing 3 on the main body 2.

[0016] The connection annulus 15 between the main body 2 and the bushing 3 serves a further purpose in that when the bushing 3 as a final step of the mounting of the connector on the cable is screwed as far as possible in the direction of the arrow A (see figure 1), the end of said connecting annulus 15 facing the center terminal 4 of the connector 1 comes into engagement with an outwardly directed circumferential protrusion 28 pro-

vided on the rear portion of the main body 2 and thereby presses the rear portion of the main body 2 firmly against the outer circumferential surface of the outer conductor 7 of the cable due to the presence of the support means 11, which is not able to yield in the radial direction, whereby a reliable electrical and mechanical connection and attachment is ensured between the main body 2 and the outer conductor 7 of the cable.

[0017] Even though one particular embodiment of the connector according to the present invention has been shown and described in the preceding detailed description, it is understood that somebody skilled in the art may conceive other embodiments hereof without departing from the scope of the invention as defined in the accompanying claims.

LIST OF PARTS

[0018]

1	Cable connector	
2	Main body (of connector)	
3	Bushing (of connector)	
4	Center terminal (of connector)	
5	Inner conductor (of cable)	
6	Insulator (of cable)	
7	Outer conductor (of cable)	
8	Jacket (of cable)	
9	Centering means (for center terminal)	
10	O-ring	
11	Support means	
12	Inclined center surface of support means	
13	Rear portion of center terminal	
14	Thread for jacket	
15	Connection annulus between main body and bushing	
16	Retainer ring	
17	O-ring	
18	Cavity between inner and outer conductor	
19	Tip of center terminal	
20	Longitudinal slits through the wall of the center terminal	
21	Longitudinal slits through the wall of the main body	
22	Rear portion of main body	
23	Collar on the support means	
24	Circular recess in inner wall of bushing	
25	Circumferential recess	
26	Recess in rear portion of main body	
27	Thread for final connection between main body and bushing	
28	Outwardly directed circumferential protrusion on rear portion of main body	
29	Contact surface between rear portion of main body and outer conductor	

Claims

- Connector for a coaxial cable, where said connector comprises a tubular main body (2) provided with a center terminal (4) electrically insulated from said main body (2), where said center terminal (4) is to be electrically connected to the inner conductor (5) of said coaxial cable, and where said main body (2) is to be electrically connected to the outer conductor (7) of said coaxial cable, characterised in that said connector comprises first means (21) provided in the rear portion of said main body (2) such that the introduction of said outer conductor (7) into said main body (2) of the connector (1) can be monitored from outside the connector (1), whereby an appropriate and reliable electrical connection directly between said outer conductor (7) and said main body (2) can be ascertained.
- Connector for a coaxial cable, where said connector comprises a tubular main body (2) provided with a center terminal (4) electrically insulated from said main body (2), where said center terminal (4) is to be electrically connected to the inner conductor (5) of said coaxial cable, and where said main body (2) is to be electrically connected to the outer conductor (7) of said coaxial cable, characterised in that said connector comprises second means (11) such that during the introduction of said outer conductor (7) into said main body (2) an appropriate and reliable electrical connection between said inner conductor (5) and said center terminal (4) will be achieved.
- Connector according to claim 1, characterised in that said first means (21) comprises a number of longitudinally extending slits through the wall of the rear portion of said main body (2), i.e. that part of said main body (2) which is located furthest away from said center terminal (4) of said conductor (1), which slits (21) make it possible for said rear portion to undergo a radial displacement thereby establishing a direct and reliable electrical connection between said rear portion of said main body (2) and the outer conductor (7) of said coaxial cable without the insertion of any intermediary parts between said main body (2) and said outer conductor (7), and through which slits (21) it is possible visually to inspect said outer conductor (7) during introduction of said cable into said connector (1).
- Connector according to claim 2, characterised in that said second means (11) comprises a substantially tubular body placed coaxially within said main body (2) and forming a circumferential gap between said main body (2) and said tubular body, where said tubular body (11) is able to be displaced longitudinally within certain limits within said main body (2), said longitudinal displacement being caused by

the end of said outer conductor (7) of said cable during insertion hereof being brought into engagement with said tubular body and thereby moving the same in the direction towards the center terminal (4) into said connector (1), and where said tubular body furthermore is provided with an end portion facing the rear portion (13) of said center terminal (4), which rear portion (13) is receiving the inner conductor (5) of said coaxial cable, and which end portion during said movement is being brought into engagement with the rear portion (13) of said center terminal (4) and thereby causes a radial compression of said rear portion (13) of said center terminal (4), so that a firm and reliable contact is being achieved between the inner surface of said rear portion (13) and the outer surface of said inner conductor (5).

5. Connector according to any of the preceding claims, characterised in that said rear portion of said main body (2) is provided with connection means (14) for engagement with the jacket (8) of said coaxial cable during mounting of said connector (1) on the end of said cable.

6. Connector according to claim 5, characterised in that said connection means (14) is formed as a thread provided on the inner surface of the rear portion of said main body (2), such that movement of the outer conductor (7) in the direction towards the center terminal (4) of the connector (1) is being caused by said main body being screwed unto the jacket (8) of said cable.

7. Connector according to any of the preceding claims, characterised in that said connector furthermore comprises a tubular bushing (3) placed concentric with said main body (2), which bushing (3) can be attached to said main body (2) in circumferentially overlapping relationship hereto and which can be displaced longitudinally relative to said main body (2) within certain limits, such that a longitudinal displacement of said bushing (3) relative to said main body (2) causes a radial compression of said rear part of said main body (2), which is provided with said longitudinal slits (21), in the direction towards the longitudinal axis of the connector (1), whereby said outer conductor (7) of said coaxial cable, which outer conductor (7) is placed in said circumferential gap between said main body (2) and said tubular body (11), is being firmly retained between the inner surface of said rear part of said main body (2) and the outer surface of said tubular body (11).

8. Connector according to claim 7, characterised in that said limits are being defined by retaining means (15, 16, 24, 25, 26) slidably positioned between said rear part of said main body (2) and said bushing (3),

such that these retaining means (15, 16, 24, 25, 26) have the combined effect of retaining said bushing (3) to said main body (2) and of causing said radial compression of said rear part of said main body (2), when said bushing (3) is being displaced relative to said main body (2) in the direction towards the center terminal (4) of the connector (1).

9. Connector according to claim 8, characterised in that said radial compression of said rear part of said main body (2) is caused by a connection annulus (15) placed between said main body (2) and said bushing (3) during said displacement of said bushing (3) relative to the main body (2) being brought into engagement with an outwardly directed protrusion (28) on the rear portion of said main body (2), said protrusion (28) on the side hereof facing said connection annulus (15) being inclined such that said longitudinal displacement of said connection annulus (15) forces said protrusion (28) - and thereby said rear portion of said main body (2) to become radially compressed towards the longitudinal axis of said connector (1).

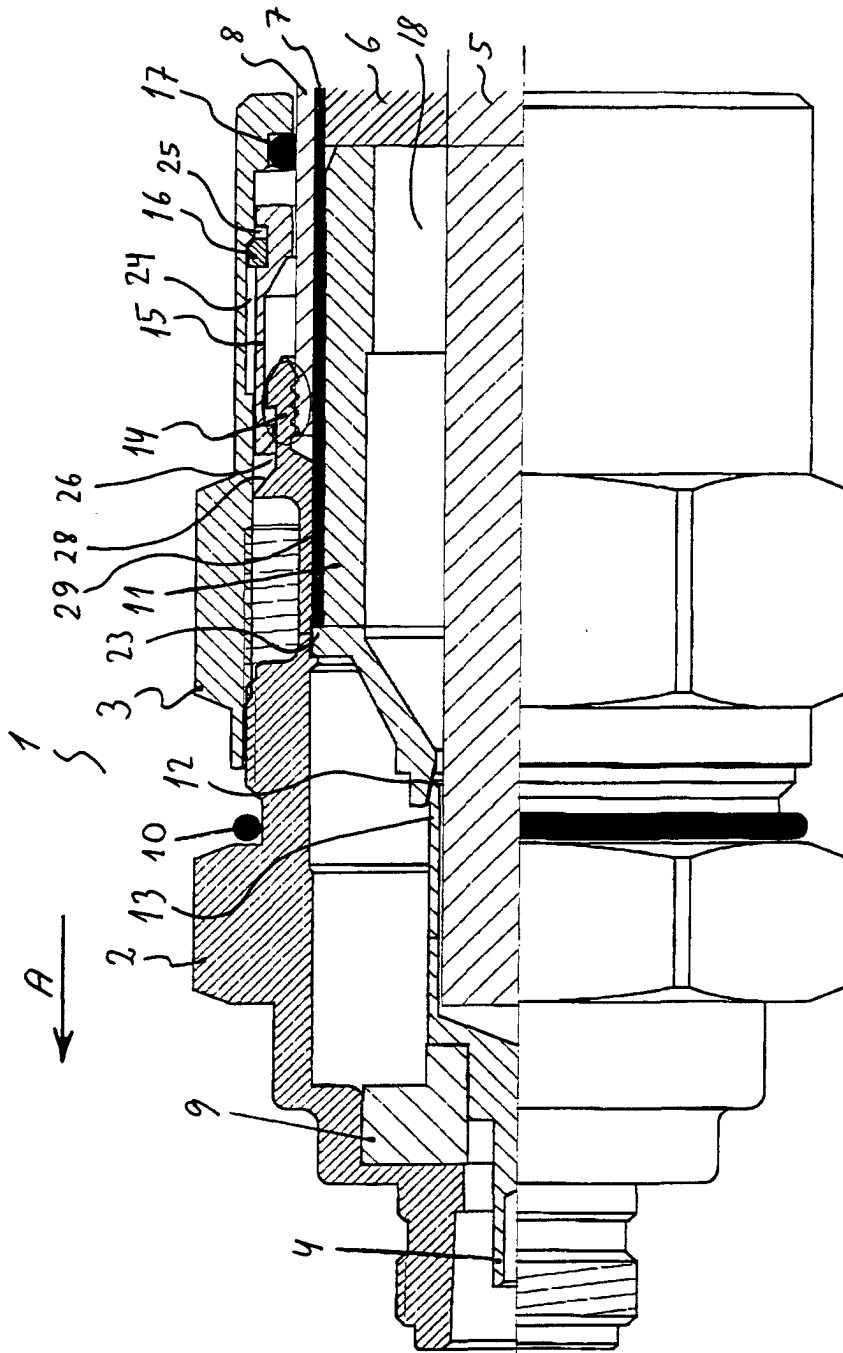

Fig. 1

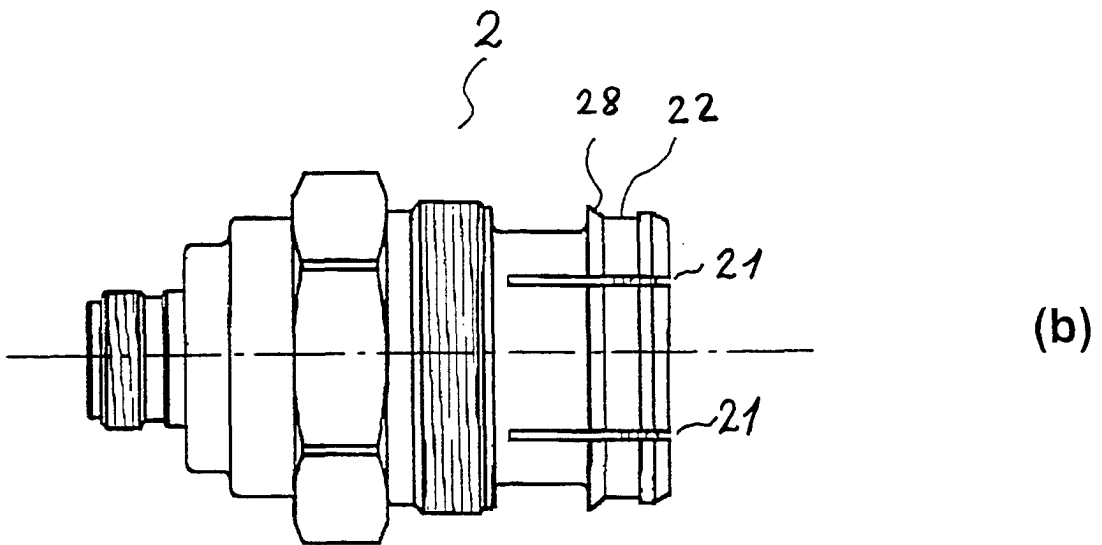
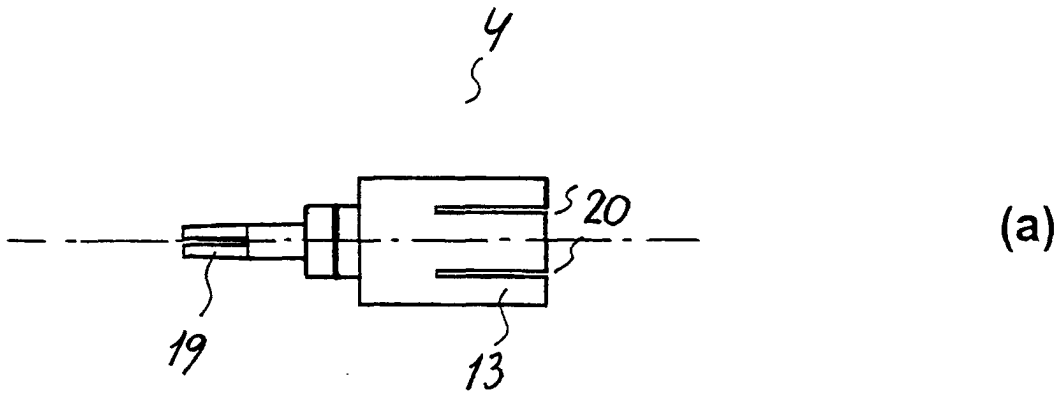

Fig. 2

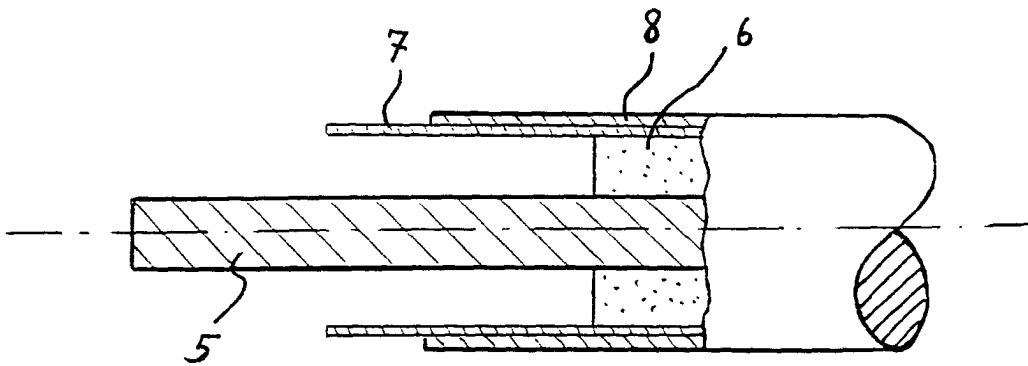

Fig. 3



European Patent
Office

EUROPEAN SEARCH REPORT

Application Number
EP 00 10 2417

DOCUMENTS CONSIDERED TO BE RELEVANT			
Category	Citation of document with indication, where appropriate, of relevant passages	Relevant to claim	CLASSIFICATION OF THE APPLICATION (Int.Cl.7)
X	US 5 651 698 A (LOCATI RONALD PETER ET AL) 29 July 1997 (1997-07-29) * the whole document * ---	1,2,4-6	H01R13/629 H01R9/05
X	EP 0 975 051 A (CON CABEL AS) 26 January 2000 (2000-01-26) * the whole document * -----	2-9	
			TECHNICAL FIELDS SEARCHED (Int.Cl.7)
			H01R
The present search report has been drawn up for all claims			
Place of search THE HAGUE		Date of completion of the search 12 July 2000	Examiner Salojärvi, K
<p>CATEGORY OF CITED DOCUMENTS</p> <p>X : particularly relevant if taken alone Y : particularly relevant if combined with another document of the same category A : technological background O : non-written disclosure P : intermediate document</p> <p>T : theory or principle underlying the invention E : earlier patent document, but published on, or after the filing date D : document cited in the application L : document cited for other reasons</p> <p>..... & : member of the same patent family, corresponding document</p>			

EPO FORM 1503 03/82 (P04/C01)

**ANNEX TO THE EUROPEAN SEARCH REPORT
ON EUROPEAN PATENT APPLICATION NO.**

EP 00 10 2417

This annex lists the patent family members relating to the patent documents cited in the above-mentioned European search report. The members are as contained in the European Patent Office EDP file on
The European Patent Office is in no way liable for these particulars which are merely given for the purpose of information.

12-07-2000

Patent document cited in search report	Publication date	Patent family member(s)	Publication date
US 5651698 A	29-07-1997	AU 720115 B	25-05-2000
		AU 7463996 A	03-07-1997
		EP 0809872 A	03-12-1997
		WO 9722162 A	19-06-1997
EP 0975051 A	26-01-2000	NONE	