



(12) **EUROPEAN PATENT APPLICATION**

(88) Date of publication A3:
23.01.2002 Bulletin 2002/04

(51) Int Cl.7: **H01R 13/629**

(43) Date of publication A2:
08.08.2001 Bulletin 2001/32

(21) Application number: **01500015.1**

(22) Date of filing: **12.01.2001**

(84) Designated Contracting States:
**AT BE CH CY DE DK ES FI FR GB GR IE IT LI LU
MC NL PT SE TR**
Designated Extension States:
AL LT LV MK RO SI

(72) Inventors:
• **Roset Rubio, Josep Maria
43800 Valls (Tarragona) (ES)**
• **Calavera Alvarez, Andreu
43800 Valls (Tarragona) (ES)**

(30) Priority: **31.01.2000 ES 200000194 U**

(74) Representative:
**Primo de Rivera y Urquijo, Jose Antonio
General Martinez Campos, 51
28010 Madrid (ES)**

(71) Applicant: **Lear Automotive (EEDS) Spain, S.L.
43800 Valls, Tarragona (ES)**

(54) **Improved electrical connector box**

(57) An improved electrical connector box made up of a housing (1) with side walls (2) and frontal opening adapted to house a sliding body (3) associated with a connector made up of two parallel arms (5) provided

with inclined parallel guides (6), causing said arms to move with respect to the housing. The side walls have pivots (8,9,10), perpendicular to the same, which are introduced inside the guides of said arms.

FIG.1

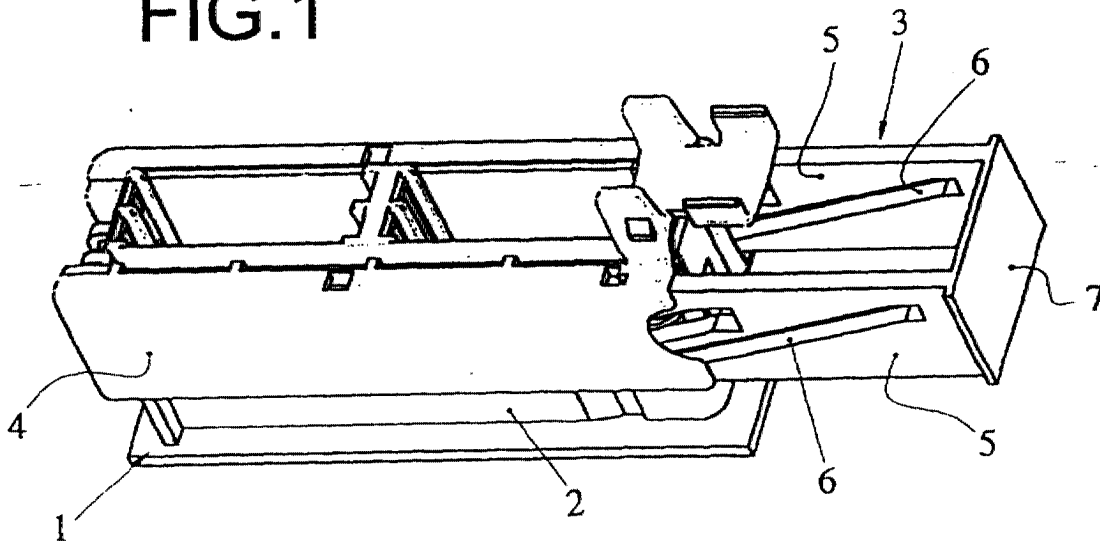



European Patent
Office

EUROPEAN SEARCH REPORT

Application Number
EP 01 50 0015

| DOCUMENTS CONSIDERED TO BE RELEVANT | | | |
|---|---|---|--|
| Category | Citation of document with indication, where appropriate, of relevant passages | Relevant to claim | CLASSIFICATION OF THE APPLICATION (Int.Cl.7) |
| X | US 5 618 195 A (CAPPE PATRICE) 8 April 1997 (1997-04-08) * abstract; figures * * column 2, line 35 - column 4, line 15 * --- | 1 | H01R13/629 |
| A | DE 89 14 038 U (KABELWERKE REINSHAGEN GMBH) 8 February 1990 (1990-02-08) * abstract; figures 2-4 * * page 8, line 24 - page 9, line 20 * * page 10, line 10 - line 26 * --- | 1,2 | |
| A | US 5 964 602 A (AOKI HIROSHI ET AL) 12 October 1999 (1999-10-12) * abstract; figure 1 * * column 5, line 26 - column 7, line 57 * ----- | 1,2 | |
| The present search report has been drawn up for all claims | | | TECHNICAL FIELDS SEARCHED (Int.Cl.7) |
| | | | H01R |
| Place of search | Date of completion of the search | Examiner | |
| THE HAGUE | 21 November 2001 | Serrano Funcia, J | |
| CATEGORY OF CITED DOCUMENTS | | T : theory or principle underlying the invention E : earlier patent document, but published on, or after the filing date D : document cited in the application L : document cited for other reasons & : member of the same patent family, corresponding document | |
| X : particularly relevant if taken alone Y : particularly relevant if combined with another document of the same category A : technological background O : non-written disclosure P : intermediate document | | | |

EPO FORM 1503 03 82 (P04601)

**ANNEX TO THE EUROPEAN SEARCH REPORT
ON EUROPEAN PATENT APPLICATION NO.**

EP 01 50 0015

This annex lists the patent family members relating to the patent documents cited in the above-mentioned European search report. The members are as contained in the European Patent Office EDP file on
The European Patent Office is in no way liable for these particulars which are merely given for the purpose of information.

21-11-2001

| Patent document cited in search report | Publication date | Patent family member(s) | Publication date |
|---|---------------------|----------------------------|---------------------|
| US 5618195 A | 08-04-1997 | FR 2730585 A1 | 14-08-1996 |
| | | DE 69607404 D1 | 04-05-2000 |
| | | DE 69607404 T2 | 07-09-2000 |
| | | EP 0726619 A1 | 14-08-1996 |
| DE 8914038 U | 08-02-1990 | DE 3910117 C1 | 13-09-1990 |
| | | DE 8914038 U1 | 08-02-1990 |
| | | AT 104803 T | 15-05-1994 |
| | | DE 59005402 D1 | 26-05-1994 |
| | | EP 0390006 A1 | 03-10-1990 |
| | | ES 2056277 T3 | 01-10-1994 |
| US 5964602 A | 12-10-1999 | JP 10021991 A | 23-01-1998 |
| | | DE 19727064 A1 | 02-01-1998 |