



Europäisches Patentamt
European Patent Office
Office européen des brevets



(11) **EP 1 143 095 A1**

(12) **EUROPEAN PATENT APPLICATION**
published in accordance with Art. 158(3) EPC

(43) Date of publication:
10.10.2001 Bulletin 2001/41

(51) Int Cl.7: **E05F 11/48**

(21) Application number: **99940211.8**

(86) International application number:
PCT/ES99/00269

(22) Date of filing: **23.08.1999**

(87) International publication number:
WO 01/14673 (01.03.2001 Gazette 2001/09)

(84) Designated Contracting States:
**AT BE CH CY DE DK ES FI FR GB GR IE IT LI LU
MC NL PT SE**
Designated Extension States:
AL LT LV MK RO SI

(72) Inventors:
• **RAUSCHER, Jochen**
E-09001 Burgos (ES)
• **PUENTE GARCIA, Rubén**
E-09004 Burgos (ES)

(71) Applicant: **Grupo Antolin Ingenieria, S.A.**
E-09007 Burgos (ES)

(74) Representative:
Urteaga Simarro, José Antonio et al
Principe de Vergara, 31
28001 Madrid (ES)

(54) **WINDOW ACTUATING DEVICE**

(57) A drive system for window winders with internal reduction, that has a toothed device (5) that transmits power to its cable drum (10), transmitting the corresponding torque, in which a spring (6) is situated, con-

nected to a rear projection of the toothed device, with this spring being housed in the interior of a bowl-shaped retainer (7), and with both occupying a position whose shaft coincides with the drive shaft.

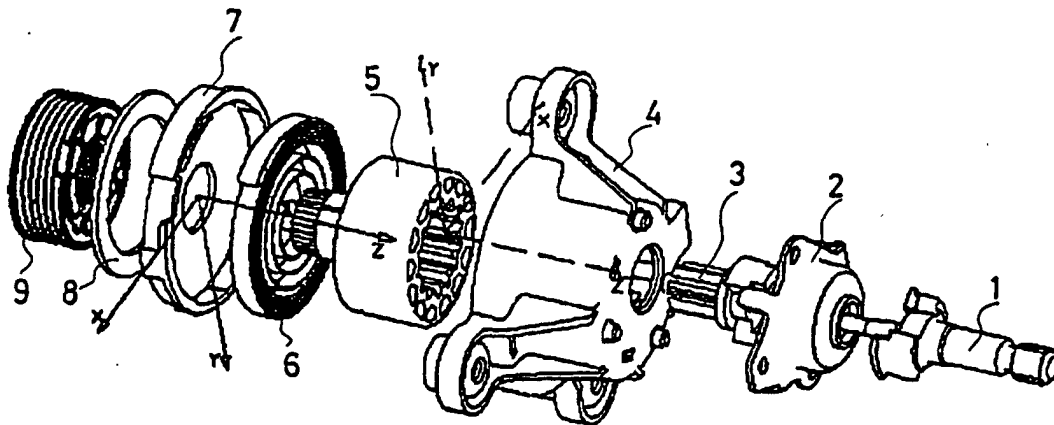

Fig:1

EP 1 143 095 A1

Description

[0001] This invention relates to a drive system for window winders with a unified kinematic chain, applicable to automobile vehicles and within the context of the technique included in EP.A. 0724060 of the same applicant.

[0002] In the said reference a window winder is described in which the movement of the kinematic chain is carried out by means of a turning device driven indifferently either manually or electrically. The kinematic chain is common for both drive systems and the said drive can be of any kind, with the characteristic that when it is manual, a reduction is placed with a braking system on the operating shaft of the window winder handle and a torque compensator by means of a suitable spring.

[0003] In the case of the present invention, the movement of the kinematic chain is carried out by means of rotation system with gear engagement, which is connected appropriately to the manual or electric drive system. This system of movement is known within these techniques.

[0004] In particular, this system is composed of a crown gear that receives a rotation movement and which, in turn, transmits a torque to a cable drum. The crown gear is operated by a pinion and in turn incorporates a toothed area, by means of which it connects with the drum already mentioned.

[0005] One object of the invention is to provide a drive system with internal reduction and compensation of high torque levels, applicable to window winder systems with a common kinematic chain and which, when it is manual, includes a compensation spring that produces a greater torque reduction.

[0006] Another object of the invention is to provide a drive system in which the compensation spring occupies a minimum space inside the mechanism.

[0007] In order to achieve these objectives, the drive system includes an end pinion which is housed inside the toothed interior of a crown gear. This crown gear is in turn provided with a toothed projection on the opposite face or side, and this projection engages with the cable drum, with the particularity that between the crown gear and the cable drum are situated a spring and a retainer that housed the said spring, and the shaft or axis of both these coincide with the shaft of the crown gear and drum.

[0008] The spring is mounted on the toothed projection of the crown gear, on the side closer to the cable drum, and its inner end is provided with a lug which is received in a longitudinal slot or groove cut in the toothed are of the crown gear.

[0009] The slot runs throughout the whole of the toothed portion of the said projection and is prolonged throughout its non-toothed portion, so that the width of the spring corresponds with the length of the said non-toothed portion, leaving the toothed part free for its adjustment with the cable drum.

[0010] The exterior of the spring is provided with a bent free end that connects with a portion of the internal side surface of the retainer that adopts the shape of a bowl, with a width noticeably equal to that of the spring and with a centred hole in order to permit the passage of the toothed portion of the projection on the crown gear towards the cable drum.

[0011] With the spring arranged on the crown gear, between it and the retainer, and with the internal and external ends secured as described, the toothed projection of the crown gear is engaged with the cable drum, following the interposition of a washer.

[0012] In this way, the alignment of the spring with the drive shaft is established and with a direct power haul connection with the crown gear that transmits the torque to the cable drum, so that it achieves the objectives foreseen previously.

[0013] The accompanying sheet of drawings allows us to observe a practical solution, non-restrictive, of the invention, in which the following are represented:

Figure 1 is a perspective of a drive system for a window winder that incorporates the object of the invention.

Figure 2 is an enlarged perspective of the constituent items of the reduction.

[0014] In accordance with Figure 1, we can appreciate the drive system items, that start with the window winder handle shaft (1), which, through the retainer (2), reaches the pinion (2, 3) and which are housed in the casing (4) towards the crown gear (5).

[0015] The crown gear has a toothed recess in which the pinion (3) is received, so that the said crown gear is made to turn when the shaft (1) turns. The opposite end of the crown gear has an axial projection finishing off in toothed portion (7), by means of which rotation movement is transmitted to the cable drum (10).

[0016] This general drive system is applicable to either a manually or an electrically operated kinematic chain for the transmission of movement to the cable drum, with the characteristic that when it is manual, a housing is fitted which is provided with the compensation spring (6) which establishes a direct connection to the power haul with the crown gear (5) that transmits the torque to the cable drum (10).

[0017] In particular, if Figure 2 we can observe the spring (6) with an internal end (15) that procures a small fin or rib, which becomes inserted into a longitudinal slot (12) in the rear axial projection of the crown gear (5), so that it becomes arranged in the non-toothed portion of the projection, leaving free the toothed portion (7) for it to fit together with the drum (10).

[0018] The external end (16) of the spring (6) is housed on an internal ledge of the retainer (8), which clasps the said spring.

[0019] Obviously, there is correspondence between

the length of the non-toothed area of the rear projection of the crown gear (5) and the widths of the spring (6) and retainer (8), so that the toothed portion of the rear projection of the crown gear (5) becomes clear for its connection to the cable drum.

5

[0020] As stated previously, the arrangement described for the spring and its location on board the longitudinal shaft or axis provides a better reduction of the torque, as well as a lower occupation of physical space in the drive system assembly unit.

10

Claims

1. Drive system for window winders with internal compensation, that has a toothed device (5) that receives the rotation of a pinion (3) operated by a shaft (1) from the exterior, in which the toothed device has a partially toothed rear projection (13) that is connected to the cable drum (10), which is **characterised in that** when the movement of the drive is manual, a spring (6) is placed, connected to the toothed device (5) through its connection to the partially toothed projection of this device, and more specifically in its non-toothed area (12), with the spring having a longitudinal shaft that coincides with that of the drive system, **in that** a bowl-shaped retainer (7) is arranged on the spring and that the internal and lower (15, 14) ends of the spring have appropriate means for them to be secured to the rear projection of the toothed device (5) and to the internal wall of the retainer (7), respectively, and with the base of the bowl shape having a central hole (16) to allow the passage of the toothed portion of the projection (13).
2. Drive system for window winders with internal compensation, in accordance with claim 1, **characterised in that** the length of the non-toothed portion (12) of the rear projection of the toothed device is fundamentally equal to the height of the spring (6) and of the retainer (7).
3. Drive system for window winders with internal compensation, in accordance with claim 1, **characterised in that** the internal part (15) of the spring (6) is a fin or rib which is received in a longitudinal slot (11) that occupies the whole of the rear projection of the toothed device (5) and the external part (14) of the spring (6) is taken into an internal projection in the side surface of the retainer (7).

55

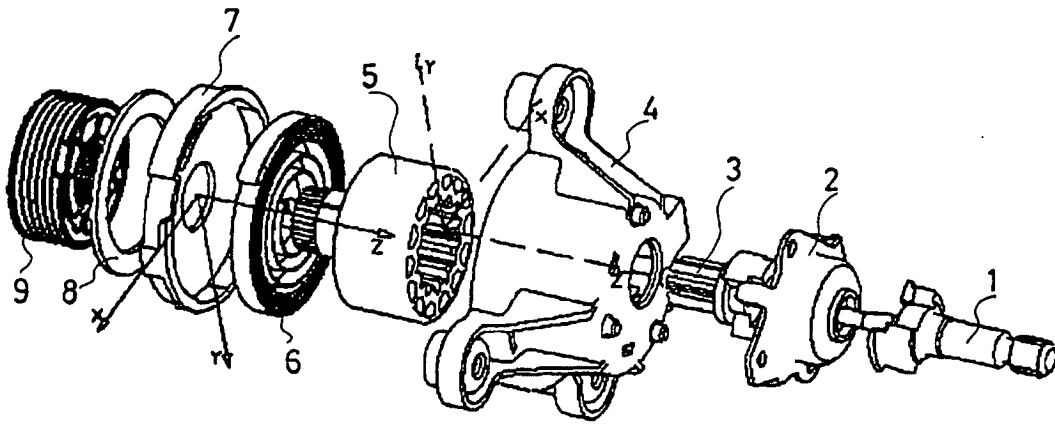

Fig:1

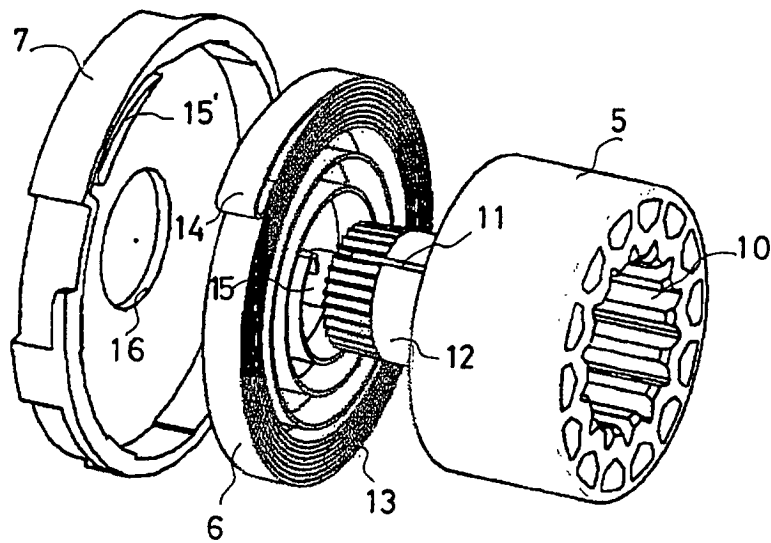

Fig: 2

INTERNATIONAL SEARCH REPORT

		International Application No PCT/ES 99/00269
A. CLASSIFICATION OF SUBJECT MATTER IPC 7 E05F11/48		
According to International Patent Classification (IPC) or to both national classification and IPC		
B. FIELDS SEARCHED		
Minimum documentation searched (classification system followed by classification symbols) IPC 7 E05F		
Documentation searched other than minimum documentation to the extent that such documents are included in the fields searched		
Electronic data base consulted during the international search (name of data base and, where practical, search terms used)		
C. DOCUMENTS CONSIDERED TO BE RELEVANT		
Category ^o	Citation of document, with indication, where appropriate, of the relevant passages	Relevant to claim No.
A	EP 0 724 060 A (IRAUSA ING SA) 31 July 1996 (1996-07-31) claims 1,4; figures 1,3,4,6 ---	1
A	US 4 821 589 A (SHIRAISHI DAIICHI ET AL) 18 April 1989 (1989-04-18) column 3, line 31 - line 63; figures 5,6 ---	1-3
A	GB 2 062 746 A (KUESTER & CO GMBH) 28 May 1981 (1981-05-28) the whole document ---	1-3
A	US 5 199 310 A (YOSHIMURA TATUO) 6 April 1993 (1993-04-06) the whole document ---	1
	-/--	
<input checked="" type="checkbox"/> Further documents are listed in the continuation of box C. <input checked="" type="checkbox"/> Patent family members are listed in annex.		
^o Special categories of cited documents :		
A document defining the general state of the art which is not considered to be of particular relevance *E* earlier document but published on or after the international filing date *L* document which may throw doubts on priority claim(s) or which is cited to establish the publication date of another citation or other special reason (as specified) *O* document referring to an oral disclosure, use, exhibition or other means *P* document published prior to the international filing date but later than the priority date claimed		*T* later document published after the international filing date or priority date and not in conflict with the application but cited to understand the principle or theory underlying the invention *X* document of particular relevance; the claimed invention cannot be considered novel or cannot be considered to involve an inventive step when the document is taken alone *Y* document of particular relevance; the claimed invention cannot be considered to involve an inventive step when the document is combined with one or more other such documents, such combination being obvious to a person skilled in the art. *&* document member of the same patent family
Date of the actual completion of the international search 13 March 2000		Date of mailing of the international search report 13. 04. 2000
Name and mailing address of the ISA European Patent Office, P.B. 5818 Patentlaan 2 NL - 2280 HV Rijswijk Tel. (+31-70) 340-2040, Tx. 31 651 epo nl, Fax: (+31-70) 340-3016		Authorized officer S. Gómez Fernández

INTERNATIONAL SEARCH REPORT

International Application No PCT/ES 99/00269

C.(Continuation) DOCUMENTS CONSIDERED TO BE RELEVANT		
Category °	Citation of document, with indication, where appropriate, of the relevant passages	Relevant to claim No.
A	US 4 503 732 A (SCHUST GERHARD) 12 March 1985 (1985-03-12) column 1, line 6 - line 38; figures -----	

INTERNATIONAL SEARCH REPORT

information on patent family members

International Application No

PCT/ES 99/00269

Patent document cited in search report	Publication date	Patent family member(s)	Publication date
EP 0724060 A	31-07-1996	ES 2120318 A	16-10-1998
US 4821589 A	18-04-1989	NONE	
GB 2062746 A	28-05-1981	DE 2945041 A	21-05-1981
		ES 492295 D	16-12-1980
		ES 8101187 A	01-03-1981
		FR 2469305 A	22-05-1981
		IT 1129258 B	04-06-1986
		ZA 8006799 A	28-10-1981
US 5199310 A	06-04-1993	JP 2925254 B	28-07-1999
		JP 4060083 A	26-02-1992
		JP 2966049 B	25-10-1999
		JP 4060084 A	26-02-1992
		JP 2925255 B	28-07-1999
		JP 4060085 A	26-02-1992
US 4503732 A	12-03-1985	DE 3148523 A	07-07-1983
		DE 3152858 A	28-07-1983
		JP 58106084 A	24-06-1983
		ZA 8208634 A	28-09-1983