



(12) **EUROPEAN PATENT APPLICATION**

(43) Date of publication:
30.01.2002 Bulletin 2002/05

(51) Int Cl.7: **F01N 3/08**, F01N 3/20,
F02D 41/02, F02M 25/07,
F01N 3/025, F02D 21/08,
F02D 41/40

(21) Application number: **01117848.0**

(22) Date of filing: **23.07.2001**

(84) Designated Contracting States:
**AT BE CH CY DE DK ES FI FR GB GR IE IT LI LU
MC NL PT SE TR**
Designated Extension States:
AL LT LV MK RO SI

- **Tsukasaki, Yukihiro**
Toyota-shi, Aichi-ken 471-8571 (JP)
- **Matsuoka, Hiroki**
Toyota-shi, Aichi-ken 471-8571 (JP)
- **Hayashi, Kotaro**
Toyota-shi, Aichi-ken 471-8571 (JP)
- **Ohtsubo, Yasuhiko**
Toyota-shi, Aichi-ken 471-8571 (JP)
- **Shibata, Daisuke**
Toyota-shi, Aichi-ken 471-8571 (JP)
- **Oda, Tomihisa**
Toyota-shi, Aichi-ken 471-8571 (JP)
- **Harada, Yasuo**
Toyota-shi, Aichi-ken 471-8571 (JP)
- **Ono, Tomoyuki**
Toyota-shi, Aichi-ken 471-8571 (JP)
- **Aoyama, Taro**
Toyota-shi, Aichi-ken 471-8571 (JP)
- **Ohki, Hisashi**
Toyota-shi, Aichi-ken 471-8571 (JP)

(30) Priority: **24.07.2000 JP 2000223053**
07.09.2000 JP 2000272186
16.02.2001 JP 2001040086

(71) Applicant: **TOYOTA JIDOSHA KABUSHIKI
KAISHA**
Aichi-ken 471-8571 (JP)

(74) Representative:
Leson, Thomas Johannes Alois, Dipl.-Ing.
Tiedtke-Bühling-Kinne & Partner GbR,
TBK-Patent, Bavariaring 4
80336 München (DE)

- (72) Inventors:
- **Ishiyama, Shinobu**
Toyota-shi, Aichi-ken,471-8571 (JP)
 - **Magarida, Naofumi**
Toyota-shi, Aichi-ken,471-8571 (JP)
 - **Kobayashi, Masaki**
Toyota-shi, Aichi-ken,471-8571 (JP)
 - **Tahara, Jun**
Toyota-shi, Aichi-ken,471-8571 (JP)
 - **Negami, Akihiko**
Toyota-shi, Aichi-ken 471-8571 (JP)
 - **Matsushita, Souichi**
Toyota-shi, Aichi-ken 471-8571 (JP)

(54) **Exhaust gas purification device for internal combustion engine**

(57) An exhaust gas purification device of an internal combustion engine in accordance with the present invention is provided with a NOx absorbent (70), which is provided in an exhaust passage (106,107) of the internal combustion engine (101), for occluding nitrogen oxide when an oxygen concentration of inflow exhaust gas is high and emitting the occluded nitrogen oxide when the oxygen concentration of the inflow exhaust gas falls, and poisoning eliminating means for, if necessity for eliminating poisoning of the NOx absorbent due to oxide arises, executing poisoning elimination processing of the NOx absorbent when the internal combustion engine is in a decelerating operation state and an idling operation state, and further provided with a particulate filter (20) on which a NOx absorbent is carried and poisoning eliminating means for, if necessity for eliminating poisoning of the particulate filter due to oxide

and/or due to particulate matters arises, executing poisoning elimination processing of the particulate filter on condition that a decelerating operation state of the internal combustion engine is detected.

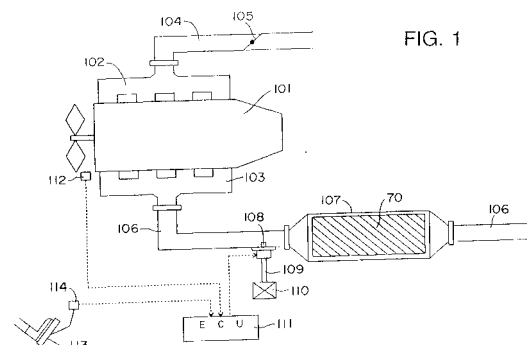

FIG. 1

Description

BACKGROUND OF THE INVENTION

1. Technical Filed

[0001] The present invention relates to a technology for purifying exhaust gas of an internal combustion engine, and in particular to an exhaust gas purification device having means for eliminating poisoning of an exhaust gas purifying catalyst, means for removing nitrogen oxide (NOx) in exhaust gas and means for removing particulate matters (PMs) in exhaust gas.

2. Description of the Related Art

[0002] In general, as a technology for purifying nitrogen oxide (NOx) contained in exhaust gas of a lean burn internal combustion engine such as a diesel engine loaded on an automobile or the like, a NOx absorbent represented by a storage-reduction NOx catalyst has been proposed. In addition, in a lean burn internal combustion engine, it has been required to purify particulate matters such as soot in addition to nitrogen oxide (NOx) contained in exhaust gas. In response to such a request, a method has been proposed which arranges a particulate filter on which a NOx absorbent is carried in an exhaust passage of an internal combustion engine.

[0003] A NOx absorbent absorbs nitrogen oxide (NOx) in exhaust gas when an oxygen concentration in inflow exhaust gas is high and emits absorbed nitrogen oxide (NOx) when the oxygen concentration of inflow exhaust gas falls.

[0004] An storage-reduction NOx catalyst, which is a sort of such a NOx absorbent, absorbs nitrogen oxide (NOx) in exhaust gas when an oxygen concentration in inflow exhaust gas is high and reduces absorbed nitrogen oxide (NOx) into nitrogen (N₂) while emitting the same when an oxygen concentration of inflow exhaust gas falls and a reducing agent exists.

[0005] If a storage-reduction NOx catalyst is disposed in an exhaust system of a lean burn internal combustion engine, when exhaust gas of a lean air-fuel ratio flows into the storage-reduction NOx catalyst, nitrogen oxide (NOx) in the exhaust gas is absorbed by the storage-reduction NOx catalyst. When exhaust gas of a stoichiometric air-fuel ratio or a rich air-fuel ratio flows into the storage-reduction NOx catalyst, nitrogen oxide (NOx) absorbed in the storage-reduction NOx catalyst is emitted as nitrogen dioxide (NO₂), and the emitted nitrogen dioxide (NO₂) reacts with a reducing component such as hydrocarbon (HC) and carbon monoxide (CO) in the exhaust gas to be reduced into nitrogen (N₂).

[0006] On the other hand, a particulate filter is a filter that is formed of a porous base material having a plurality of pores and collects PMs in exhaust gas when the exhaust gas flows through the pores.

[0007] Therefore, it becomes possible to remove ni-

trogen oxide (NOx) and PMs contained in exhaust gas by disposing a particulate filter on which a NOx absorbent is carried in an exhaust passage of an internal combustion engine.

5 **[0008]** In addition, fuel of an internal combustion engine may include a sulfur (S) component. If such fuel is burnt in the internal combustion engine, the sulfur (S) component in the fuel is oxidized and sulfur oxide (SOx) such as SO₂ and SO₃ is formed. Thus, exhaust gas emitted from the internal combustion engine contains sulfur oxide (SOx).

10 **[0009]** When exhaust gas containing sulfur oxide (SOx) flows into a NOx absorbent such as a storage-reduction NOx catalyst, the sulfur oxide (SOx) is absorbed in the NOx absorbent by a mechanism similar to that for nitrogen oxide (NOx). However, the nitrogen oxide (NOx) absorbed in the NOx absorbent forms stable barium sulfate (BaSO₄) as time passes. Thus, the sulfur oxide is hard to be decomposed and emitted simply by decreasing an oxygen concentration of exhaust gas flowing into the NOx absorbent and tends to be accumulated in the NOx absorbent.

15 **[0010]** Then, when the accumulated amount of SOx in the NOx absorbent increases, ability for absorbing NOx of the NOx absorbent falls and nitrogen oxide (NOx) in the exhaust gas cannot be sufficiently removed. That is, so-called SOx poisoning occurs. Therefore, if the NOx absorbent is disposed in an exhaust passage of an internal combustion engine, it is necessary to eliminate the SOx poisoning of the NOx absorbent before the ability of absorbing NOx of the NOx absorbent excessively falls.

20 **[0011]** As a method of eliminating the SOx poisoning of a NOx absorbent, there is known a method of raising the atmospheric temperature of the NOx absorbent up to a high temperature area of approximately 500 °C to 700 °C and turning an air-fuel ratio of exhaust gas flowing into the NOx absorbent into a rich air-fuel ratio, thereby thermally decomposing barium sulfate (BaSO₄) into SO₃⁻ or SO₄⁻ and then causing SO₃⁻ or SO₄⁻ to react with hydrocarbon (HC) or carbon dioxide (CO) in the exhaust gas to reduce it into SO₂⁻ of a gas form.

25 **[0012]** On the other hand, ability for collecting PMs of a particulate filter is also limited. When particulate matters equal to or exceeding the ability for collecting PMs are collected in the particulate filter, an exhaust passage in the particulate filter is clogged and troubles such as excessive increase of a exhaust pressure are caused. That is, so-called PM poisoning occurs. Therefore, if a particulate filter is disposed in an exhaust passage of an internal combustion engine, it is necessary to eliminate the PM poisoning of the particulate filter before an exhaust pressure excessively rises.

30 **[0013]** As a method of eliminating the PM poisoning of a particulate filter, there is known a method of raising a temperature of the particulate filter up to a high temperature area of approximately 500 °C to 700 °C and turning an air-fuel ratio of exhaust gas flowing into the

particulate filter into a lean air-fuel ratio, thereby oxidizing (burning) the particulate matters (PMs).

[0014] Therefore, if a particulate filter on which a NOx absorbent is carried is disposed in an exhaust passage of an internal combustion engine, it is necessary to properly eliminate the SOx poisoning or the PM poisoning of the particulate filter. When eliminating the SOx poisoning and the PM poisoning of the particulate filter, it is necessary to raise the temperature of the particulate filter to a high temperature area of 500 °C or more. Thus, it is possible to perform SOx poisoning elimination processing or PM poisoning elimination processing at the time of a high load and high-speed rotation operation when an exhaust gas temperature of the internal combustion engine rises.

[0015] However, when the internal combustion engine is in the state of the high load and high-speed rotation operation, an amount of exhaust gas emitted from the internal combustion engine increases. Thus, there is a problem in that a large amount of fuel corresponding to the emission amount is necessary for turning an air-fuel ratio of the emission into a rich air-fuel ratio in order to eliminate the SOx poisoning of the particulate filter, which causes increase of a fuel consumption amount.

[0016] In order to cope with such a problem, an exhaust gas purification device of an internal combustion engine as described in Japanese Patent Application Laid-open No. Hei 8-170558 has been conventionally proposed.

[0017] The exhaust gas purification device of the internal combustion engine described in the above-mentioned patent application heats a catalyst and controls an air-fuel ratio of exhaust gas flowing into the catalyst to be in a richer side than a stoichiometric air-fuel ratio at the time of the idling operation when a flow rate of exhaust gas decreases, thereby intending to eliminate poisoning of the catalyst while suppressing increase of a fuel consumption amount in accordance with unnecessary cooling of the catalyst by the exhaust gas and enrichment of the exhaust gas.

[0018] Incidentally, when an internal combustion engine is in the state of idling operation, a flow rate of exhaust gas emitted in a unit time from the internal combustion engine decreases, and the flow rate of exhaust gas flowing into a catalyst in the unit time decreases as well accordingly. Thus, an amount of fuel flowing into the catalyst in the unit time also decreases when the air-fuel ratio of the exhaust gas is turned into a rich air-fuel ratio. In particular, if a storage-reduction NOx catalyst is used, an amount of a reducing agent flowing into the catalyst in the unit time also decreases.

[0019] Therefore, in an exhaust gas purification device, in which the poisoning elimination processing is executed only at the time of idling operation as in the above-mentioned conventional exhaust gas purification device, an internal combustion engine needs to be idly operated for a long period of time in order to eliminate poisoning of a catalyst. If the idling operation of the in-

ternal combustion engine is not continued for a long period of time, it becomes difficult to eliminate the poisoning of the catalyst.

[0020] On the other hand, when the idling operation of the internal combustion engine is continued for a long time and the air-fuel ratio of exhaust gas is turned into a rich air-fuel ratio continuously during that period, an amount of reducing agent adsorbed on a wall surface of an exhaust passage in more upstream than an exhaust gas purification catalyst may excessively increase. Therefore, in an exhaust gas purification device in which poisoning elimination processing of a catalyst is executed only at the time of idling operation as in the above-mentioned conventional exhaust gas purification device, an internal combustion engine needs to be operated idly for a long period of time in order to eliminate the poisoning of the catalyst. If the idling operation of the internal combustion engine is not continued for a long period of time, it becomes difficult to sufficiently eliminate the poisoning of the catalyst.

[0021] When the operation state of the internal combustion engine is shifted from an idling operation state to an accelerating operation state with a large amount of reducing agent adsorbed on the wall surface of the exhaust passage, it is likely that the relatively large amount of reducing agent adsorbed on the wall surface of the exhaust passage is desorbed from the wall surface of the exhaust passage all at once and flows into the catalyst due to a rise of an exhaust pressure.

[0022] When the large amount of reducing agent desorbed from the wall surface of the exhaust passage flows into the catalyst, it is likely that the reducing agent rapidly burns in the catalyst and the catalyst deteriorates due to heating.

[0023] The present invention has been devised in view of the above and other drawbacks, and it is an object of the present invention to provide a technology that is capable of surely eliminating poisoning due to oxidation of a NOx absorbent while preventing unnecessary deterioration of the NOx absorbent in an exhaust gas purification device in which the NOx absorbent is disposed in an exhaust system of an internal combustion engine.

[0024] Moreover, if the above-mentioned conventional exhaust gas purification device is applied to a particulate filter on which a NOx absorbent is carried, it is necessary to perform PM poisoning elimination processing in addition to SOx poisoning elimination processing. Thus, it is assumed that it becomes difficult to sufficiently perform the SOx poisoning elimination processing and the PM poisoning elimination processing if the processing is performed only at the time of the idling operation.

[0025] It is another object of the present invention to provide a technology that is capable of surely eliminating, in an exhaust gas purification device of an internal combustion engine provided with such a particulate filter on which a NOx absorbent is carried, the SOx poisoning and the PM poisoning of the particulate filter without un-

necessarily increasing a fuel consumption amount.

SUMMARY OF THE INVENTION

[0026] The present invention adopts the following means in order to solve the subject of providing a technology that is capable of surely eliminating poisoning due to oxidization of a NOx absorbent while preventing unnecessary deterioration of the NOx absorbent in the above-mentioned exhaust gas purification device in which the NOx absorbent is disposed in the exhaust system of the internal combustion engine.

[0027] That is, an exhaust gas purification device of an internal combustion engine in accordance with the present invention is characterized by comprising:

a NOx absorbent, which is provided in an exhaust passage of the internal combustion engine, for occluding nitrogen oxide when an oxygen concentration of inflow exhaust gas is high and emitting the occluded nitrogen oxide when the oxygen concentration of the inflow exhaust gas falls; and poisoning eliminating means for, if necessity for eliminating poisoning of the NOx absorbent due to oxide arises, executing poisoning elimination processing of the NOx absorbent when the internal combustion engine is in an decelerating operation state and an idling operation state.

[0028] In the exhaust gas purification device of the internal combustion engine configured as above, when necessity for eliminating poisoning of a NOx absorbent due to oxide arises, the poisoning eliminating means executes the poisoning elimination processing of the NOx absorbent on condition that the operation state of the internal combustion engine is in the idling operation state or in the decelerating operation state.

[0029] That is, in the exhaust gas purification device of the internal combustion engine in accordance with the present invention, if necessity for eliminating poisoning of the NOx absorbent due to oxide arises, the poisoning elimination processing of the NOx absorbent is also executed when the operation state of the internal combustion engine is in the decelerating operation state in addition to when the operation state of the internal combustion engine is in the idling operation state.

[0030] As a result, an area for executing the poisoning elimination processing is enlarged, and it becomes easy to secure time for executing the poisoning elimination processing.

[0031] Further, the poisoning eliminating means may turn an air-fuel ratio of exhaust gas flowing into a NOx absorbent into a stoichiometric air-fuel ratio or a rich air-fuel ratio in the poisoning elimination processing.

[0032] An exhaust gas purification device of an internal combustion engine in accordance with the present invention may be characterized by comprising:

a NOx catalyst, which is provided in an exhaust passage of the internal combustion engine, for occluding nitrogen oxide when an oxygen concentration of inflow exhaust gas is high and reducing and purifying the occluded nitrogen oxide while emitting it when an oxygen concentration of the inflow exhaust gas falls and a reducing agent exists;

reducing agent adding means for adding the reducing agent in an exhaust passage in more upstream than the NOx catalyst; and

poisoning eliminating means for, if necessity for eliminating poisoning of the NOx catalyst due to oxide arises, controlling the reducing agent adding means in order to eliminate poisoning of the NOx catalyst when the internal combustion engine is in the decelerating operation state or the idling operation state.

[0033] In the exhaust gas purification device of the internal combustion engine configured as above, when necessity for eliminating poisoning of a NOx absorbent due to oxide arises, the poisoning eliminating means controls the reducing agent adding means in order to execute the poisoning elimination processing of the NOx absorbent on condition that the operation state of the internal combustion engine is in the idling operation state or in the decelerating operation state.

[0034] In this case, the poisoning elimination processing of a NOx absorbent is also executed when the operation state of the internal combustion engine is in the decelerating operation state in addition to when the operation state of the internal combustion engine is in the idling operation state. Thus, an area for executing the poisoning elimination processing is enlarged, and as a result, it becomes easy to secure time for executing the poisoning elimination processing.

[0035] Further, under a situation in which it is necessary to eliminate poisoning of the NOx catalyst due to oxide, when the internal combustion engine is in the decelerating operation state or in the idling operation state, the poisoning eliminating means may control the reducing agent adding means such that the air-fuel ratio of the exhaust gas flowing into the NOx catalyst turns into a stoichiometric air-fuel ratio or a rich air-fuel ratio. When the internal combustion engine is neither in the decelerating operation state nor in the idling operation state, the poisoning eliminating means may control the reducing agent adding means such that the air-fuel ratio of the exhaust gas flowing into the NOx catalyst turns into a lean air-fuel ratio.

[0036] This is because an exhaust gas purification device is assumed which is configured such that a reducing agent is added to an exhaust passage in more upstream than a NOx catalyst.

[0037] In addition, when the internal combustion engine is continuously operated idly for a predetermined time or more and then operated acceleratingly during the execution of the poisoning elimination processing,

the poisoning eliminating means may control the reducing agent adding means in order to prohibit the addition of the reducing agent for a predetermined period from the start of the accelerating operation.

[0038] Here, when the internal combustion engine is in the idling operation state, since a flow rate of exhaust gas is a little and a pressure of the exhaust gas is low, the reducing agent added to the exhaust passage from the reducing agent adding means tends to adsorb on the wall surface or the like of the exhaust passage in more upstream than the NOx catalyst.

[0039] When the idling operation state of the internal combustion engine is continued for a long period of time, a large amount of reducing agent adsorbs on the wall surface of the exhaust passage in more upstream than the NOx catalyst. The reducing agent that has adsorbed on the wall surface of the exhaust passage is desorbed from the wall surface of the exhaust passage and flows into the NOx catalyst when the flow rate of exhaust gas is large and the exhaust gas pressure is high as in the case in which the internal combustion engine is in the accelerating operation state.

[0040] Therefore, when the internal combustion engine is continuously operated idly for a predetermined time or more and then acceleratingly operated, a large amount of reducing agent, which has adsorbed on the wall surface of the exhaust passage at the time of the idling operation of the internal combustion engine, is desorbed from the wall surface of the exhaust passage all at once at the time of the accelerating operation of the internal combustion engine and flows into the NOx catalyst. Thus, when the reducing agent is added to the exhaust passage from the reducing agent adding means under such a situation, an excessive reducing agent is supplied to the NOx catalyst and the reducing agent rapidly burns the NOx catalyst to heat the NOx catalyst.

[0041] On the other hand, when the internal combustion engine is continuously operated idly for a predetermined time or more and then acceleratingly operated during the execution of the poisoning elimination processing, if the addition of the reducing agent is prohibited for a predetermined period from the start of the accelerating operation, only the reducing agent desorbed from the wall surface of the exhaust passage flows into the NOx catalyst. The reducing agent added in the exhaust passage from the reducing agent adding means never flows into the NOx catalyst all at once in addition to the reducing agent desorbed from the wall surface of the exhaust passage.

[0042] The above-mentioned predetermined period may be a fixed value or a variable value that is changed according to the idling operation continuation time of the internal combustion engine.

[0043] In addition, the poisoning eliminating means in accordance with the present invention may prohibit supply of the reducing agent when the idling operation continuation time of the internal combustion engine ex-

ceeds an upper limit value set in advance.

[0044] A NOx catalyst in accordance with the present invention can be exemplified by a storage-reduction NOx catalyst, and oxide in accordance with the present invention can be exemplified by sulfur oxide (SOx).

[0045] Moreover, the present invention adopts the following means in order to solve the subject of providing a technology for, in the exhaust gas purification device of the internal combustion engine provided with the particulate filter on which the above-mentioned NOx absorbent is carried, surely eliminating the SOx poisoning and the PM poisoning of the particulate filter without unnecessarily increasing a fuel consumption amount.

[0046] That is, an exhaust gas purification device of an internal combustion engine in accordance with the present invention is provided with:

a particulate filter, which is provided in an exhaust passage of an internal combustion engine, for absorbing nitrogen oxide in exhaust gas when an oxygen concentration of inflow exhaust gas is high and emitting the absorbed nitrogen oxide when the oxygen concentration of the inflow exhaust gas falls; and

poisoning eliminating means for, if necessity for eliminating poisoning of the particulate filter due to oxide or due to particulate matters arises, executing poisoning elimination processing of the particulate filter when a decelerating operation state of the internal combustion engine is detected.

[0047] In the exhaust gas purification device of the internal combustion engine configured as above, when necessity for eliminating poisoning of the particulate filter due to oxide and/or particulate matters arises, the poisoning eliminating means executes the poisoning elimination processing of the particulate filter on condition that the decelerating operation state of the internal combustion engine is detected.

[0048] In this case, the poisoning elimination processing of the particulate filter is also executed in an idling operation period in addition to the decelerating operation period if the internal combustion engine shifts from the decelerating operation state to the idling operation state in addition to a period in which the internal combustion engine is in the decelerating operation state.

[0049] As a result, an area for executing the poisoning elimination processing is enlarged compared with the case in which the poisoning elimination processing is executed only when the internal combustion engine is in the idling operation state.

[0050] In addition, in the exhaust gas purification device of the internal combustion engine in accordance with the present invention, when necessity for eliminating poisoning of the particulate filter due to oxide and particulate matters arises, the poisoning eliminating means may turn an air-fuel ratio of exhaust gas flowing into the particulate filter into a rich air-fuel ratio for a first

predetermined period and into a lean air-fuel ratio for a subsequent second predetermined period from the time when the decelerating operation state of the internal combustion engine is detected.

[0051] In this case, in the first predetermined period from the time when the decelerating operation state of the internal combustion engine is detected, the air-fuel ratio of the exhaust gas flowing into the particulate filter is turned into a rich air-fuel ratio. Thus, the exhaust gas flowing into the particulate filter becomes exhaust gas containing a relatively large amount of reducing component such as hydrocarbon (HC) and carbon dioxide (CO).

[0052] When the exhaust gas containing a large amount of reducing component flows into the particulate filter, oxide poisoning the particulate filter tends to react with the reducing component in the exhaust gas. As a result, elimination of the poisoning of the particulate filter due to the oxide is prompted.

[0053] Subsequently, in the second predetermined period after the first predetermined period has passed since the decelerating operation state of the internal combustion engine is detected, the air-fuel ratio of the exhaust gas flowing into the particulate filter is turned into a lean air-fuel ratio. Thus, the exhaust gas flowing into the particulate filter becomes exhaust gas containing a relatively large amount of oxygen.

[0054] When the exhaust gas containing a large amount of oxygen flows into the particulate filter, particulate matters poisoning the particulate filter tends to react with the oxygen contained in the exhaust gas. As a result, elimination of the poisoning of the particulate filter due to the particulate matters is prompted.

[0055] As described above, when the processing for eliminating the poisoning of the particulate filter due to oxide and due to particulate matters is performed on condition that the decelerating operation state of the internal combustion engine is detected, the poisoning elimination processing is also executed in the idling operation period in addition to the decelerating operation period if the internal combustion engine shifts from the decelerating operation state to the idling operation state in addition to a period in which the internal combustion engine is in the decelerating operation state.

[0056] As a result, an execution period of the poisoning elimination processing with respect to oxide and an execution period of the poisoning elimination processing with respect to particulate matters are sufficiently secured.

[0057] Further, a method of changing an air-fuel ratio of exhaust gas flowing into a particulate filter can be exemplified by a method of changing the air-fuel ratio by controlling a sub-injection amount by a fuel injection valve for directly injecting fuel into a cylinder of an internal combustion engine and/or an adding amount of adding means for adding fuel in an exhaust passage in the upstream of the particulate filter.

[0058] In addition, in the exhaust gas purification de-

vice of the internal combustion engine in accordance with the present invention, if an exhaust gas re-circulating mechanism for re-circulating a part of exhaust gas flowing through the exhaust passage of the internal combustion engine to an intake passage is further provided, the poisoning eliminating means may control the exhaust gas re-circulating mechanism in order to increase an exhaust gas amount to be re-circulated from the exhaust passage to the intake passage when eliminating poisoning of the particulate filter due to oxide.

[0059] In this case, in the period when the elimination processing of the poisoning of the particulate filter due to oxide is performed, an amount of exhaust gas to be re-circulated from the exhaust passage to the intake passage is increased. Thus, an amount of fresh air decreases instead of an amount of exhaust gas to be inhaled in the internal combustion engine increased.

[0060] As a result, an amount of oxygen to be inhaled in the internal combustion engine decreases, and an amount of oxygen contained in exhaust gas emitted from the internal combustion engine also decreases accordingly. Thus, it becomes possible to reduce an amount of fuel (or a reducing agent) required when turning an air-fuel ratio of the exhaust gas into a rich air-fuel ratio. Moreover, in the internal combustion engine in which combustion is prohibited when it is in the decelerating operation state, intake gas of the internal combustion engine is emitted as exhaust gas as it is. Thus, when an amount of fresh air to be inhaled in the internal combustion engine is decreased, and an amount of fresh air flowing into the particulate filter decreases, it becomes possible to suppress the particulate filter to be cooled by the fresh air of a relatively low temperature.

[0061] In addition, in the exhaust gas purification device of the internal combustion engine in accordance with the present invention, if an intake throttle valve, which is provided in an intake passage of the internal combustion engine, for adjusting a flow rate of intake gas flowing in the intake passage is further provided, the poisoning eliminating means may reduce an opening degree of the intake throttle valve when eliminating poisoning of the particulate filter due to oxide.

[0062] In this case, in the period when the elimination processing of poisoning of the particulate filter due to oxide is executed, an amount of fresh air to be inhaled in the internal combustion engine is decreased. Thus, an amount of exhaust gas emitted from the internal combustion engine also decreases accordingly.

[0063] As a result, it becomes possible to reduce an amount of fuel (or a reducing agent) required when turning an air-fuel ratio of the exhaust gas into a rich air-fuel ratio. Moreover, in the internal combustion engine in which combustion is prohibited when it is in the decelerating operation state, intake gas of the internal combustion engine is emitted as exhaust gas as it is. Thus, when an amount of fresh air inhaled in the internal combustion engine is decreased, and an amount of fresh air flowing into the particulate filter decreases, it becomes

possible to suppress the particulate filter to be cooled by the fresh air of relatively low temperature.

[0064] In addition, if the exhaust gas purification device of the internal combustion engine in accordance with the present invention is provided with both the exhaust gas re-circulating mechanism and the intake throttle valve, the poisoning eliminating means may reduce an amount of fresh air to be inhaled in the internal combustion engine by using both the exhaust gas re-circulating mechanism and the intake throttle valve when eliminating poisoning of the particulate filter due to oxide.

[0065] In addition, the exhaust gas purification device of the internal combustion engine in accordance with the present invention may be further provided with decelerating torque generating means for generating a desired decelerating torque when the poisoning elimination processing of the particulate filter is executed.

[0066] This is because a case is assumed in which combustion is performed in the internal combustion engine in order to suppress fall of exhaust gas temperature, in other words, fall of a temperature of the particulate filter in the poisoning elimination processing of the particulate filter. This is also because it is likely that a negative torque (so-called engine braking force) generated by the internal combustion engine is reduced and decelerating performance of an automobile loaded with the internal combustion engine declines if combustion of air-fuel mixture is performed in the internal combustion engine when it is in the decelerating operation state.

[0067] Here, a method of generating a decelerating torque can be exemplified by a method of decreasing a torque generated by the internal combustion engine, a method of increasing braking force by a braking device provided in the automobile mounted with the internal combustion engine, a method of properly combining these two methods, or the like.

[0068] In addition, a method of decreasing the torque generated by the internal combustion engine can be exemplified by a method of advancing a combustion timing of the internal combustion engine, more preferably a method of advancing a combustion timing to before a dead point on a compressing stroke.

[0069] When air-fuel mixture is burnt before the dead point on the compressing stroke in the internal combustion engine, a pressure (combustion pressure) generated by the combustion of the air-fuel mixture prevents rising operation of a piston. As a result, a torque of the internal combustion engine falls.

[0070] Here, in advancing the combustion timing of the internal combustion engine, an ignition time may be advanced if the internal combustion engine in accordance with the present invention is a gasoline engine provided with an ignition plug. Alternatively, a fuel injection timing may be advanced if the internal combustion engine in accordance with the present invention is a diesel engine of a compressing ignition type that is not provided with an ignition plug.

[0071] Moreover, if the internal combustion engine in accordance with the present invention is a diesel engine of the compressing ignition type and is an internal combustion engine provided with main fuel injecting means for injecting main fuel supplied for combustion into a cylinder and pilot injecting means for injecting secondary fuel into a cylinder prior to the injection of the main fuel, the decelerating torque generating means may advance the fuel injection timing of the main fuel injecting means and the fuel injection timing of the pilot injecting means.

[0072] In addition, if the internal combustion engine in accordance with the present invention is provided with an exhaust gas re-circulating mechanism, the decelerating torque generating means may advance the fuel injection timing of the internal combustion engine and also increase an exhaust gas amount to be re-circulated by the exhaust gas re-circulating mechanism.

[0073] In general, exhaust gas of the internal combustion engine contains an inactive gas component such as carbon dioxide (CO₂) and water (H₂O). Thus, if exhaust gas re-circulated by the exhaust gas re-circulating mechanism is contained in air-fuel mixture, combustion heat of the air-fuel mixture is absorbed due to incompleteness and endothermism that the inactive gas component has, and a combustion pressure that is generated when the air-fuel mixture burns falls accordingly.

[0074] Therefore, when the combustion injection period of the internal combustion engine is advanced and an exhaust gas amount to be re-circulated by the exhaust gas re-circulating mechanism is increased, the decelerating torque of the internal combustion engine tends to be generated.

[0075] Other objects and features of the present invention will be apparent from the following descriptions taken in conjunction with the accompanying drawings, in which like reference characters designate the same or similar parts throughout the figures thereof.

BRIEF DESCRIPTION OF THE DRAWINGS

[0076] In the accompanying drawings:

Fig. 1 is a schematic illustration showing a configuration of an internal combustion engine to which an exhaust gas purification device in accordance with the present invention is applied and an intake and exhaust system of the same;

Fig. 2 illustrates a mechanism for occluding and emitting NO_x of a storage-reduction NO_x catalyst, and (A) and (B) illustrate a mechanism for occluding NO_x of the storage-reduction NO_x catalyst and a mechanism for emitting NO_x of the storage-reduction NO_x catalyst, respectively;

Fig. 3 is a flow chart showing a routine of SO_x poisoning elimination processing in accordance with a first embodiment;

Fig. 4 is a flow chart showing a routine of SO_x poisoning elimination processing in accordance with a

second embodiment;

Fig. 5 is a schematic illustration showing an internal combustion engine to which an abnormality detecting device of a reducing agent supplying device in accordance with the present invention is applied and an intake and exhaust system of the same;

Figs. 6(A) and 6(B) are a front view and a sectional view of a particulate filter, respectively;

Fig. 7 is a block diagram showing an internal configuration of an ECU of Fig. 5;

Fig. 8 illustrates poisoning elimination control in accordance with a third embodiment;

Fig. 9 is a flow chart showing a routine of the poisoning elimination control in accordance with the third embodiment; and

Fig. 10 illustrates a relation between an injection timing of main fuel and a pressure inside a pipe in a fourth embodiment.

Fig. 11 illustrates a relation between an injection timing of main fuel and a pressure inside a pipe in a fourth embodiment.

DETAILED DESCRIPTION OF THE PREFERRED EMBODIMENTS

[0077] Specific embodiments of an exhaust gas purification device of an internal combustion engine in accordance with the present invention will be hereinafter described with reference to the drawings.

[0078] Fig. 1 is a schematic illustration showing a configuration of an internal combustion engine to which an exhaust gas purification device in accordance with the present invention is applied and an intake and exhaust system of the same.

[0079] An internal combustion engine 101 shown in Fig. 1 is a diesel engine for driving an automobile. An intake branch line 102 and an exhaust branch line 103 are connected to this internal combustion engine 101.

[0080] The intake branch line 102 is connected to an intake pipe 104, and the intake pipe 104 is connected to an intake duct via a not-shown air cleaner box in the upstream. An intake throttle valve 105 for adjusting a flow rate of intake gas flowing through the intake pipe 104 is disposed in the middle of the intake pipe 104.

[0081] On the other hand, the exhaust branch line 103 is connected to an exhaust pipe 106, and the exhaust pipe 106 is connected to a not-shown muffler in the downstream. A casing 107, which contains a storage-reduction NOx catalyst as a NOx absorbent in accordance with the present invention, is disposed in the middle of the exhaust pipe 106. A fuel adding nozzle 108, which adds fuel being a reducing agent to exhaust gas flowing in the exhaust pipe 106, is attached to the exhaust pipe 106 in the upstream of the casing 107.

[0082] The fuel adding nozzle 108 is connected to a fuel pump 110 via a fuel pipe 109 and is allowed to inject fuel discharged from the fuel pump 110 into the exhaust pipe 106.

[0083] An storage-reduction NOx catalyst 70 contained in the casing 107 is formed having, for example, alumina as a carrier and at least one element selected out of, for example, alkaline metals such as potassium (K), sodium (Na), lithium (Li) or cesium (Cs), alkaline earth such as barium (Ba) or calcium (Ca) and rare earth such as lanthanum (La) or yttrium (Y) and a precious metal such as platinum (Pt) carried on the carrier.

[0084] Here, a ratio of air and fuel (hydrocarbon (HC)) supplied into an exhaust passage in the upstream of an intake passage of the internal combustion engine 101 and the storage-reduction NOx catalyst 70 is referred to as an air-fuel ratio of exhaust gas (hereinafter abbreviated as an exhaust gas air-fuel ratio) flowing into the storage-reduction NOx catalyst 70. The storage-reduction NOx catalyst 70 absorbs nitrogen oxide (NOx) in the exhaust gas when the exhaust gas air-fuel ratio turns into a lean air-fuel ratio and an oxygen concentration in the exhaust gas is high. On the other hand, the storage-reduction NOx catalyst 70 performs a NOx absorbing and emitting action for emitting the absorbed nitrogen oxide (NOx) when the exhaust gas air-fuel ratio turns into a stoichiometric air-fuel ratio or a rich air-fuel ratio and the oxygen concentration in the exhaust gas falls.

[0085] The NOx absorbing and emitting action of the storage-reduction NOx catalyst 70 is considered to be performed by a mechanism schematically shown in Fig. 2. This mechanism will be hereinafter described with reference to a case in which platinum (Pt) and barium (Ba) are carried on a carrier made of alumina as an example. A similar mechanism is also realized using other precious metals, alkaline metals, alkaline earth or rare earth.

[0086] First, when an exhaust gas air-fuel ratio turns into a lean air-fuel ratio and an oxygen concentration in exhaust gas rises, oxygen (O₂) in the exhaust gas adsorbs on a surface of platinum (Pt) in the form of O₂⁻ or O²⁻ as shown in Fig. 2(A). On the other hand, nitrogen monoxide (NO) contained in the exhaust gas reacts with O₂⁻ or O²⁻ on the surface of the platinum (Pt) to be nitrogen dioxide (NO₂) ($2NO + O_2 \rightarrow 2NO_2$).

[0087] Subsequently, a part of the nitrogen dioxide (NO₂) is absorbed in the storage-reduction NOx catalyst 70 while being oxidized on the platinum (Pt) and diffuses into the storage-reduction NOx catalyst 70 in the form of a nitrate ion (NO₃⁻) while combining with barium oxide (BaO).

[0088] In this way, the nitrogen oxide (NOx) in the exhaust gas is absorbed in the storage-reduction NOx catalyst 70. A NOx absorptive action of the storage-reduction NOx catalyst 70 is continued as long as the oxygen concentration of the exhaust gas flowing into the storage-reduction NOx catalyst 70 is high and a NOx absorbing ability of the storage-reduction NOx catalyst 70 does not saturate.

[0089] On the other hand, when the exhaust gas air-fuel ratio turns into a stoichiometric air-fuel ratio or a rich air-fuel ratio and the oxygen concentration in the ex-

haust gas falls, an amount of nitrogen dioxide (NO_2) generation decreases on the surface of the platinum (Pt) as shown in Fig. 2(B). Thus, the nitrite ion (NO_3^-) bonded with the barium oxide (BaO) reversely turns into nitrogen dioxide or nitrogen monoxide (NO) and is emitted from the storage-reduction NOx catalyst 70.

[0090] In this instance, a part of unburnt fuel component (hydrocarbon (HC)) and carbon monoxide (CO) existing in the exhaust gas react with the oxygen (O_2^- or O^{2-}) on the platinum (Pt) to be oxidized. The remaining hydrocarbon (HC) and carbon monoxide (CO) react with the nitrogen dioxide (NO_2) and the nitrogen monoxide (NO) emitted from the storage-reduction NOx catalyst 70 to reduce the nitrogen dioxide (NO_2) and the nitrogen monoxide (NO) into nitrogen (N_2).

[0091] That is, the hydrocarbon (HC) and the carbon monoxide (CO) in the exhaust gas first react with the oxygen (O_2^- or O^{2-}) on the platinum (Pt) to be oxidized. Subsequently, if the hydrocarbon (HC) and the carbon monoxide (CO) remain in the exhaust gas after the oxygen (O_2^- or O^{2-}) on the platinum (Pt) is consumed, the hydrocarbon (HC) and the carbon monoxide (CO) (in particular, an active species of the hydrocarbon (HC) and the carbon monoxide (CO) partly oxidized by the oxygen (O_2^- or O^{2-})) reduce the nitrogen oxide (NOx) emitted from the storage-reduction NOx catalyst 70 and the nitrogen oxide (NOx) emitted from the internal combustion engine 101 into nitrogen (N_2).

[0092] With the storage-reduction NOx catalyst 70 as described above, when the exhaust gas air-fuel ratio is a lean air-fuel ratio, nitrogen oxide (NOx) in the exhaust gas is absorbed in the absorbing and reducing type NOx catalyst 70 and nitrogen oxide (NOx) in the exhaust gas is removed. When the exhaust gas air-fuel ratio is a stoichiometric air-fuel ratio or a rich air-fuel ratio, the nitrogen oxide (NOx) absorbed in the storage-reduction NOx catalyst 70 is reduced into nitrogen (N_2) while being emitted from the storage-reduction NOx catalyst 70, and the nitrogen oxide (NOx) emitted from the internal combustion engine 101 is also reduced into nitrogen (N_2) or the like in the storage-reduction NOx catalyst 70.

[0093] In the internal combustion engine 101 configured as above, an electronic control unit (ECU) 111 for controlling an operation state of the internal combustion engine 101 is also provided. This ECU 111 is composed of, for example, a CPU, a ROM, a RAM, a backup RAM, an input port or an output port and the like that are connected each other by a bidirectional bus.

[0094] The fuel adding nozzle 108 is electrically connected to the ECU 111 in addition to various sensors such as a crank position sensor 112 for outputting a pulse signal each time a not-shown crank shaft of the internal combustion engine 101 rotates a predetermined angle (e.g. 10°) and an acceleration pedal position sensor 114 for outputting an electric signal corresponding to an operated amount of an acceleration pedal 113 provided in a cabin. Thus, it is possible to control the fuel adding nozzle 108 with output signals of the crank po-

sition sensor 112, the acceleration pedal position sensor 114 and the like as parameters.

[0095] For example, in a diesel engine such as the internal combustion engine 101, the diesel engine is operated by lean burn in most operation areas. Thus, it is assumed that an air-fuel ratio of exhaust gas flowing into the storage-reduction NOx catalyst 70 turns into a lean air-fuel ratio in most operation areas as well, a NOx emitting action cannot catch up with the NOx absorptive action of the storage-reduction NOx catalyst 70, and the NOx absorbing ability of the storage-reduction NOx catalyst 70 saturates.

[0096] Here, if the internal combustion engine 101 is operated by lean burn, the ECU 111 controls the reducing agent adding nozzle 108 in order to turn an air-fuel ratio of exhaust gas flowing into the storage-reduction NOx catalyst 70 into a stoichiometric air-fuel ratio or a rich air-fuel ratio in a relatively short period in a spike-like manner (short time), that is, executes so-called rich spike control, thereby allowing emission and reduction of nitrogen oxide (NOx) in a short period in the storage-reduction NOx catalyst 70.

[0097] On the other hand, a sulfur (S) component may be contained in fuel of the internal combustion engine 101. When such fuel is burnt, the sulfur (s) component in the fuel is oxidized and sulfur oxide (SOx) such as SO_2 and SO_3 is generated.

[0098] When the sulfur oxide (SOx) as described above flows into the storage-reduction NOx catalyst 70 together with the exhaust gas, the storage-reduction NOx catalyst 70 absorbs the sulfur oxide (SOx) by a mechanism similar to that for the nitrogen oxide (NOx).

[0099] That is, when the air-fuel ratio of the exhaust gas flowing into the storage-reduction NOx catalyst 70 is a lean air-fuel ratio, oxygen (O_2) adsorbs on a surface of a platinum (Pt) of the storage-reduction NOx catalyst 70 in the form of O_2^- or O^{2-} as mentioned in the description of the NOx absorptive action. Thus, the sulfur oxide (SOx) (e.g., SO_2) in the exhaust air is oxidized on the surface of the platinum (Pt) to be SO_3 .

[0100] Subsequently, the SO_3 is absorbed in the storage-reduction NOx catalyst 70 while being further oxidized on the surface of the platinum (Pt) to combine with barium oxide (BaO) and diffuses into the storage-reduction NOx catalyst 70 in the form of a sulfate ion (SO_4^{2-}) to generate barium sulfate (BaSO_4).

[0101] Incidentally, since the above-mentioned barium sulfate (BaSO_4) is stable and hard to be decomposed, it remains in the storage-reduction NOx catalyst 70 without being decomposed even if the air-fuel ratio of the inflow exhaust gas is turned into a rich air-fuel ratio. Therefore, when a generated amount of barium sulfate (BaSO_4) increases as time passes, an amount of barium oxide (BaO) that can participate in the absorption of the storage-reduction NOx catalyst 70 decreases, whereby the NOx absorbing ability of the storage-reduction NOx catalyst 70 falls, that is, so-called SOx poisoning occurs.

[0102] Thus, in the exhaust gas purification device of the internal combustion engine in accordance with this embodiment, the ECU 111 estimates an amount of sulfate oxide (SOx) absorbed in the storage-reduction NOx catalyst 70 with an operation history or the like of the internal combustion engine 101 as a parameter. When the estimated amount reaches an upper limit value, the ECU 111 executes poisoning elimination processing in order to emit the sulfur oxide (SOx) from the storage-reduction NOx catalyst 70.

[0103] As a method of eliminating SOx poisoning of the storage-reduction NOx catalyst 70, a method is considered to be effective which raises a catalyst bed temperature up to a temperature area (e.g., 600 to 650 °C) that is higher than a temperature in which NOx emitting and reducing action is performed and then turns the exhaust gas air-fuel ratio into a stoichiometric air-fuel ratio or a rich air-fuel ratio.

[0104] According to such a method, the barium sulfate (BaSO₄) occluded in the storage-reduction NOx catalyst 70 is decomposed into SO₃. The SO₃ is reduced by hydrocarbon (HC) or carbon monoxide (CO) in the exhaust gas to SO₂ and emitted.

[0105] Poisoning elimination processing in accordance with the present invention will be hereinafter described specifically.

<First embodiment>

[0106] First, SOx poisoning elimination processing in accordance with a first embodiment will be described.

[0107] The SOx poisoning elimination processing in accordance with this embodiment is executed when the internal combustion engine 101 is in an idling operation state or a decelerating operation state.

[0108] When the internal combustion engine 101 is in the idling operation state or in the decelerating operation state, a flow rate of exhaust gas decreases. Thus, even if an injection amount of the fuel adding nozzle 108 is reduced to relatively little, it becomes possible to turn the exhaust gas air-fuel ratio into a stoichiometric air-fuel ratio or a rich air-fuel ratio.

[0109] In doing so, if the opening degree of the intake throttle valve 105 is tightened, the amount of intake gas in the internal combustion engine 101 is reduced and the flow rate of the exhaust gas is further reduced accordingly. Thus, even if the injection amount of the fuel adding nozzle 108 is further reduced, it becomes possible to turn the exhaust gas air-fuel ratio into a stoichiometric air-fuel ratio or a rich air-fuel ratio.

[0110] The SOx poisoning elimination processing in this embodiment will be hereinafter described along a flow chart of Fig. 3.

[0111] The flow chart shown in Fig. 3 is a flow chart showing a routine of SOx poisoning elimination processing. The routine of the SOx poisoning elimination processing is a routine to be executed repeatedly at each predetermined time (e.g., each time the crank po-

sition sensor 12 outputs a pulse signal) by the ECU 111.

<Step S101>

[0112] First, in step S101, the ECU 111 estimates an amount of sulfate oxide (SOx) absorbed in the storage-reduction NOx catalyst 70. A method of estimating an absorbed amount of sulfate oxide (SOx) can be exemplified by a method of calculating an absorbed amount of sulfate oxide (SOx) in the storage-reduction NOx catalyst 70 for a unit time with the number of engine rotations and an output signal value (opening degree of acceleration pedal) of the acceleration pedal position sensor 114 as parameters and accumulating amounts of sulfate oxide (SOx), thereby estimating the absorbed amount of sulfate oxide (SOx) in the storage-reduction NOx catalyst 70.

[0113] In doing so, a relation between the number of engine rotations, the opening degree of an acceleration pedal and the absorbed amount of sulfate oxide may be found experimentally in advance to mapping the relation in advance.

<Step S102>

[0114] In step S102, the ECU 111 determines whether or not the absorbed amount of sulfate oxide (SOx) calculated in step S101 is a predetermined upper limit value or more. Here, if it is determined that the absorbed amount of sulfate oxide (SOx) is less than the predetermined upper limit value, the ECU 111 ends the execution of this routine at this point. On the other hand, if it is determined that the absorbed amount of sulfate oxide (SOx) is the predetermined upper limit value or more, the ECU 111 advances to step S103.

<Step S103>

[0115] In step S103, the ECU 111 determines whether or not the internal combustion engine 101 is in a decelerating operation state. A method of determining the decelerating operation state of the internal combustion engine 101 is exemplified by a method of determining that the internal combustion engine 101 is in the decelerating operation state when such a condition that an opening degree of an acceleration pedal is "0", a running speed of an automobile is not "0" or an operating amount of a not-shown braking pedal is not "0" is met.

[0116] In this step S103, if it is determined that the internal combustion engine 101 is not in the decelerating operation state, the ECU 111 advances to step S104. On the other hand, if it is determined in step S103 that the internal combustion engine 101 is in the decelerating operation state, the ECU 111 advances to step S105.

<Step S104>

[0117] In step S104, the ECU 111 determines whether

or not the internal combustion engine 101 is in an idling operation state. A method of determining the idling operation state of the internal combustion engine 101 is exemplified by a method of determining that the internal combustion engine 101 is in the idling operation state when such a condition that an opening degree of an acceleration pedal is "0", the number of engine rotations is less than a predetermined number of rotations or a running speed of an automobile is "0" is met.

[0118] If it is determined in this step S104 that the internal combustion engine 101 is not in the idling operation state, the ECU 111 ends execution of this routine at this point. On the other hand, if it is determined in step S104 that the internal combustion engine 101 is in the idling operation state, the ECU 111 advances to step S105.

<Step S105>

[0119] In step S105, the ECU 111 executes poisoning elimination processing in order to recover SOx poisoning of the storage-reduction NOx catalyst 70. In the poisoning elimination processing, the ECU 111 turns an air-fuel ratio of exhaust gas flowing into the storage-reduction NOx catalyst 70 into a stoichiometric air-fuel ratio or a rich air-fuel ratio by, for example, adding a reducing agent in the exhaust pipe 106 from the reducing agent injecting nozzle 108, thereby emitting sulfate oxide (SOx) from the storage-reduction NOx catalyst 70 while raising a bed temperature of the storage-reduction NOx catalyst 70.

[0120] Poisoning eliminating means in accordance with the present invention is realized by the ECU 111 executing the above-mentioned routine of poisoning elimination processing.

[0121] Therefore, according to the exhaust gas purification device of the internal combustion engine in accordance with this embodiment, the poisoning elimination processing is executed when the internal combustion engine 101 is in the decelerating operation state as well in addition to when it is in the idling operation state. Thus, an execution time of the SOx poisoning elimination processing can be sufficiently secured compared with the case in which the SOx poisoning elimination processing is executed only when the internal combustion engine 101 is in the idling operation state.

<Second embodiment>

[0122] SOx poisoning elimination processing in accordance with a second embodiment will now be described.

[0123] In the SOx poisoning elimination processing in accordance with this embodiment, an operation state of the internal combustion engine 101 in which SOx poisoning elimination processing is being executed is monitored. When the operation state of the internal combustion engine 101 shifts from an idling operation state to

an accelerating operation state during the execution of the SOx poisoning elimination processing, addition of fuel by the fuel adding nozzle 108 is prohibited.

[0124] When the internal combustion engine 101 is in the idling operation state, all of the fuel added in the exhaust pipe 106 from the fuel adding nozzle 108 does not reach the storage-reduction NOx catalyst 70, and some adsorbs on the wall surface or the like of the exhaust pipe 106 in the upstream of the storage-reduction NOx catalyst 70 and remains there.

[0125] If the idling operation state of the internal combustion engine 101 is continued for a long period during the execution of the SOx poisoning elimination processing, an amount of fuel piling up in the exhaust pipe 106 in the upstream of the storage-reduction NOx catalyst 70 increases. Under such a situation, when the operation state of the internal combustion engine 101 shifts from the idling operation state to the accelerating operation state, a large amount of fuel remaining in the exhaust pipe 106 in more upstream than the storage-reduction NOx catalyst 70 may flow into the storage-reduction NOx catalyst 70 all at once and rapidly burn in the storage-reduction NOx catalyst 70.

[0126] When a large amount of fuel rapidly burns in the storage-reduction NOx catalyst 70 in this way, it is likely that the storage-reduction NOx catalyst 70 is heated by heat generated when the fuel burns and the storage-reduction NOx catalyst 70 is thermally deteriorated.

[0127] In order to cope with this problem, in the SOx poisoning elimination processing in accordance with this embodiment, the ECU 111 monitors a continuation time of the idling operation and, when the continuation time reaches a predetermined time or more, prohibits addition of fuel in the exhaust pipe 106 from the fuel adding nozzle 108.

[0128] Moreover, in the SOx poisoning elimination processing in accordance with this embodiment, when the internal combustion engine 101 is continuously operated idly for a predetermined time or more and then continues to be operated in the accelerating operation state, addition of fuel in the exhaust pipe 106 from the fuel adding nozzle 108 is prevented for a predetermined period from a point when the acceleration operation is started.

[0129] Further, the above-mentioned predetermined period may be a fixed value that is set in advance or a variable value that is changed according to the continuation time of the idling operation state.

[0130] The SOx poisoning elimination processing in this embodiment will be hereinafter described along a flow chart of Fig. 4.

[0131] The flowchart shown in Fig. 4 is a flow chart showing a monitoring routine of the SOx poisoning elimination processing. The monitoring routine of the SOx poisoning elimination processing is a routine that is executed repeatedly at each predetermined time (e.g., each time the crank position sensor 12 outputs a pulse signal) by the ECU 111.

<Step S201>

[0132] In step S201, the ECU 111 determines whether or not the SOx poisoning elimination processing is being executed.

[0133] If it is determined in this step S201 that the SOx poisoning elimination processing is not being executed, the ECU 111 ends the execution of this routine at this point. On the other hand, if it is determined in step S201 that the SOx poisoning elimination processing is being executed, the ECU 111 advances to step S202.

<Step S202>

[0134] In step S202, the ECU 111 determines whether or not the continuation time of the idling operation state is shorter than a predetermined time or whether or not an elapsed time from the point when the internal combustion engine 101 shifted from the idling operation state to the accelerating operation state is longer than a predetermined time.

[0135] If it is determined in this step S202 that the continuous time of the idling operation state is less than the predetermined time or the elapsed time from the point when the internal combustion engine 101 shifted from the idling operation state to the accelerating operation state is longer than the predetermined time, the ECU 111 ends the execution of this routine at this point.

[0136] On the other hand, if it is determined in step S202 that the continuous time of the idling operation state is the predetermined time or more and the elapsed time from the point when the internal combustion engine 101 shifted from the idling operation state to the accelerating operation state is the predetermined time or less, the ECU 111 advances to step S203.

<Step S203>

[0137] In step S203, the ECU 111 prohibits addition of fuel in the exhaust pipe 106 from the fuel adding nozzle 108.

[0138] According to the embodiment described above, if the internal combustion engine 101 is continuously operated idly for a predetermined time or more during the execution of the SOx poisoning elimination processing and then shifted to the accelerating operation, the fuel remaining in the exhaust pipe 106 at the time of the idling operation and the fuel added from the fuel adding nozzle 108 do not flow into the storage-reduction NOx catalyst 70 all at once any more. Thus, excessive fuel does not rapidly burn in the storage-reduction NOx catalyst 70, whereby deterioration of the storage-reduction NOx catalyst 70 due to heating is prevented.

[0139] Therefore, in the exhaust gas purification device of the internal combustion engine in accordance with the present invention, when necessity for eliminating poisoning of NOx absorbent or NOx catalyst due to

oxide arises, the poisoning elimination processing is also executed when the internal combustion engine is in the decelerating operation state in addition to when the internal combustion engine is in the idling operation state. Thus, an area for executing the poisoning elimination processing is enlarged, whereby a time for executing the poisoning elimination processing is sufficiently secured easily.

[0140] As a result, the poisoning of the NOx absorbent or the NOx catalyst due to oxide can be eliminated in a short period.

[0141] In addition, according to the exhaust gas purification device of the internal combustion engine in accordance with the present invention, even if it is necessary to turn an air-fuel ratio of exhaust gas into a stoichiometric air-fuel ratio or a rich air-fuel ratio, the poisoning elimination processing is executed when a flow rate of exhaust gas is relatively little such as when the internal combustion engine is in the idling operation state and in the decelerating operation state. Thus, it becomes possible to turn the exhaust gas air-fuel ratio into the stoichiometric air-fuel ratio or the rich air-fuel ratio by a relatively little amount of fuel.

[0142] In addition, if the exhaust gas purification device of the internal combustion engine in accordance with the present invention is provided with reducing agent adding means for adding a reducing agent in an exhaust passage in the upstream of the NOx catalyst, when the internal combustion engine continues the idling operation state for a predetermined time or more under the situation in which the poisoning elimination processing is executed and then shifts to the accelerating operation state, addition of the reducing agent is prohibited in a predetermined period from the start of the accelerating operation. Thus, the reducing agent remaining in the exhaust passage at the time of the idling operation and the reducing agent added in the exhaust passage by the reducing agent adding means never flow into the NOx catalyst all at once.

[0143] As a result, the excessive reducing agent is not oxidized (burns) all at once in the NOx catalyst and heating of the NOx catalyst due to combustion of the reducing agent is prevented, whereby it becomes possible to suppress thermal deterioration of the NOx catalyst.

[0144] A third and a fourth embodiments will now be described with a case in which the exhaust gas purification device in accordance with the present invention is applied to a diesel engine for driving an automobile as an example.

<Third embodiment>

[0145] First, a third embodiment of the exhaust gas purification device of the internal combustion engine in accordance with the present invention will be described with reference to Fig. 2 and Figs. 5 to 8.

[0146] Fig. 5 is a schematic illustration showing an internal combustion engine to which the exhaust gas pu-

rification device in accordance with the present invention is applied and an intake and exhaust system of the same.

[0147] An internal combustion engine 1 shown in Fig. 5 is a water cooling four-stroke-cycle diesel engine having four cylinders 2.

[0148] The internal combustion engine 1 is provided with a fuel injection valve 3 for directly injecting fuel into a combustion chamber of each cylinder 2. Each fuel injection valve 3 is connected to an accumulation chamber (common rail) 4 that accumulate fuel to a predetermined pressure. A common rail pressure sensor 4a, which outputs an electric signal corresponding to a pressure of fuel in the common rail 4, is attached to this common rail 4.

[0149] The common rail 4 communicates with a fuel pump 6 via a fuel supply pipe 5. This fuel pump 6 is a pump that is actuated with a rotation torque of an output shaft (crank shaft) of the internal combustion engine 1 as a driving source. A pump pulley 6a attached to an input shaft of the fuel pump 6 is coupled to a crank pulley 1a attached to the output shaft (crank shaft) of the internal combustion engine 1 via a belt 7.

[0150] In a fuel injection system configured as described above, when a rotation torque of the crank shaft is transmitted to the input shaft of the fuel pump 6, the fuel pump 6 discharges fuel at a pressure corresponding to the rotation torque transmitted to the input shaft of the fuel pump 6.

[0151] The fuel discharged from the fuel pump 6 is supplied to the common rail 4 via the fuel supply pipe 5 and accumulated to a predetermined pressure in the common rail 4. The fuel accumulated to the predetermined pressure in the common rail 4 is distributed to the fuel injection valve 3 of each cylinder 2. The fuel injection valve 3 opens when a driving current is applied to it and injects fuel into the combustion chamber of each cylinder 2.

[0152] Next, an intake branch line 8 is connected to the internal combustion engine 1. Each branch line of the intake branch line 8 communicates with the combustion chamber of each cylinder 2 via a not-shown intake port.

[0153] The intake branch line 8 is connected to an intake pipe 9, which is connected to an air cleaner box 10. An air flow meter 11 for outputting an electric signal corresponding to a mass of intake gas flowing in the intake pipe 9 and an intake gas temperature sensor 12 for outputting an electric signal corresponding to a temperature of intake gas flowing in the intake pipe 9 are attached to the intake pipe 9 in the downstream of the air cleaner box 10.

[0154] An intake throttle valve 13, which adjusts a flow rate of intake gas flowing in the intake pipe 9, is provided in a part positioned in the immediately upstream of the intake branch line 8 in the intake pipe 9. An actuator for intake throttle 14, which is composed of a stepper motor or the like and drives to open and close the

intake throttle valve 13, is attached to this intake throttle valve 13.

[0155] A compressor housing 15a of a centrifugal supercharger (turbo charger), which operates with thermal energy of exhaust gas as a driving source, is provided in the intake pipe 9 positioned between the air flow meter 11 and the intake throttle valve 13. An inter-cooler 16, which cools intake gas that is compressed in the compressor housing 15a to have a high temperature, is provided in the intake pipe 9 in the downstream of the compressor housing 15a.

[0156] In an intake system configured as above, intake gas having flown in the air cleaner box 10 flows into the compressor housing 15a via the intake pipe 9 after dust, dirt or the like is removed from it by a not-shown air cleaner in the air cleaner box 10.

[0157] The intake gas having flown in the compressor housing 15a is compressed by rotation of a compressor wheel provided in the compressor housing 15a. The intake gas, which is compressed in the compressor housing 15a to have a high temperature, is cooled in the inter-cooler 16 and then has its flow rate adjusted by the intake throttle valve 13 if necessary to flow into the intake branch line 8. The intake gas having flown in the intake branch line 8 is distributed to the combustion chamber of each cylinder 2 via each branch line and burnt with the fuel injected from the fuel injection valve 3 of each cylinder 2 as an ignition source.

[0158] On the other hand, an exhaust branch line 18 is connected to the internal combustion engine 1. Each branch line of the exhaust branch line 18 communicates with the combustion chamber of each cylinder 2 via a not-shown exhaust port.

[0159] The exhaust branch line 18 is connected to a turbine housing 15b of the centrifugal supercharger 15. The turbine housing 15b is connected to an exhaust pipe 19, which is connected to a not-shown muffler in the downstream.

[0160] A particulate filter 20 for removing and purifying a poisonous gas component in exhaust gas is disposed in the middle of the exhaust pipe 19. An air-fuel ratio sensor 23, which outputs an electric signal corresponding to an air-fuel ratio of exhaust gas flowing in the exhaust pipe 19, and an exhaust gas temperature sensor 24, which outputs an electric signal corresponding to a temperature of the exhaust gas flowing in the exhaust pipe 19, are attached to the exhaust pipe 19 in the downstream of the particulate filter 20.

[0161] An exhaust throttle valve 21, which adjusts a flow rate of exhaust gas flowing in the exhaust pipe 19, is provided in the exhaust pipe 19 in the downstream of the air-fuel ratio sensor 23 and the exhaust gas temperature sensor 24. An actuator for exhaust throttle 22, which is composed of a stepper motor or the like and drives the exhaust throttle valve 21 to open and close, is attached to the exhaust throttle valve 21.

[0162] In the exhaust system composed as above, air-fuel mixture (burnt gas) burnt in each cylinder 2 of

the internal combustion engine 1 is discharged to the exhaust branch line 18 via the exhaust port and then flows into the turbine housing 15b of the centrifugal supercharger 15 from the exhaust branch line 18. The exhaust gas having flown in the turbine housing 15b rotates a turbine wheel, which is rotatably supported in the turbine housing 15b, utilizing thermal energy that the exhaust gas has. In this instance, a rotation torque of the turbine wheel is transmitted to the above-mentioned compressor wheel of the compressor housing 15a.

[0163] The exhaust gas emitted from the turbine housing 15b flows into the particulate filter 20 via the exhaust pipe 19, and a poisonous gas component in the exhaust gas is removed or purified. The exhaust gas from which the poisonous gas component is removed or purified in the particulate filter 20 is emitted to the atmosphere via a muffler after a flow rate is adjusted by the exhaust throttle valve 21 if necessary.

[0164] In addition, the exhaust branch line 18 and the intake branch line 8 are communicated each other via an exhaust re-circulating passage (EGR passage) 25 that re-circulates a part of exhaust gas flowing in the exhaust branch line 18 to the intake branch line 8. In the middle of this EGR passage 25, a flow rate adjusting valve (EGR valve) 26 is provided which is composed of an electromagnetic valve or the like and changes a flow rate of exhaust gas flowing in the EGR passage 25 (hereinafter referred to as EGR gas) according to a magnitude of applied electricity.

[0165] An EGR cooler 27, which cools EGR gas flowing in the EGR passage 25, is provided in a part in the upstream of the EGR valve 26 in the EGR passage 25.

[0166] In the exhaust re-circulating mechanism configured as above, when the EGR valve 26 is opened, the EGR passage 25 is in a communicating state, and a part of the exhaust gas flowing in the exhaust branch line 18 flows into the EGR passage 25 and is guided to the intake branch line 8 via the EGR cooler 27.

[0167] In this instance, heat exchange is performed between the EGR gas flowing in the EGR passage 25 and a predetermined refrigerant in the EGR cooler 27, and the EGR gas is cooled.

[0168] The EGR gas circulated from the exhaust branch line 18 to the intake branch line 8 via the EGR passage 25 is guided to the combustion chamber of each cylinder 2 while being mixed with fresh air flowing from the upstream of the intake branch line 8. Then, the EGR gas is burnt with fuel injected from the fuel injection valve 3 as an ignition source.

[0169] Here, the EGR gas does not burn by itself as water (H₂O), carbon dioxide (CO₂) or the like does not and contains an inactive gas component having endothermism. Thus, when the EGR gas is contained in air-fuel mixture, a combustion temperature of the air-fuel mixture is lowered, whereby a generated amount of nitrogen oxide (NO_x) is suppressed.

[0170] Moreover, when the EGR gas is cooled in the EGR cooler 27, a temperature of the EGR gas itself falls

and a volume of the EGR gas is reduced simultaneously. Thus, the atmospheric temperature in a combustion chamber does not unnecessarily rise when the EGR gas is supplied to the combustion chamber, and an amount of fresh air (a volume of fresh air) to be supplied into the combustion chamber does not unnecessarily decrease as well.

[0171] The particulate filter 20 in accordance with this embodiment will now be described specifically.

[0172] Fig. 6 illustrates a configuration of the particulate filter 20. Fig. 6(A) shows a front view of the particulate filter 20 and. Fig. 6(B) shows a side sectional view of the particulate filter 20.

[0173] As shown in Figs. 6(A) and 6(B), the particulate filter 20 is a wall flow type filter consisting of a porous base material in which a first exhaust passage 50 closed by a plug 52 at its end on the downstream side and a second exhaust passage 51 closed by a plug 53 at its end on the upstream side are disposed alternately each other and in a honey-comb shape via a partition wall 54. Further, a base material of the particulate filter 20 is exemplified by cogerite, ceramics or the like.

[0174] An storage-reduction NO_x catalyst is carried on a surface of the partition wall 54 of the particulate filter 20 and on an internal surface of pores of the partition wall 54, which absorbs nitrogen oxide (NO_x) contained in exhaust gas flowing through the particulate filter 20 when an oxygen concentration of the exhaust gas is high and reduces the absorbed nitrogen oxide (NO_x) into nitrogen (N₂) while emitting it when the oxygen concentration of the exhaust gas flowing through the particulate filter falls and a reducing agent such as hydrocarbon (HC) exists.

[0175] The storage-reduction NO_x catalyst is formed having, for example, alumina (Al₂O₃) as a carrier and one element selected out of, for example, alkaline metals such as potassium (K), sodium (Na), lithium (Li) or cesium (Cs), alkaline earth such as barium (Ba) or calcium (Ca) and rare earth such as lanthanum (La) or yttrium (Y) and a precious metal such as platinum (Pt) carried on the carrier.

[0176] In the particulate filter 20 configured as above, exhaust gas having flowed into the particulate filter 20 flows into the first exhaust passage 50 first and then flows to the second exhaust passage 51 through pores of the surrounding partition walls 54 as shown by an arrow in Fig. 6(B).

[0177] When exhaust gas passes through the partition wall 54, so-called particulate matters such as soot or SOFs (soluble organic fractions) contained in the exhaust gas are collected.

[0178] In addition, if the air-fuel ratio of exhaust gas flowing into the particulate filter 20 is an air-fuel ratio with excessive oxygen (lean air-fuel ratio), the storage-reduction NO_x catalyst carried on the particulate filter 20 absorbs nitrogen oxide (NO_x) in the exhaust gas. Then, when the air-fuel ratio of the exhaust gas flowing into the particulate filter 20 turns into a stoichiometric air-fuel

ratio or a rich air-fuel ratio and an oxygen concentration falls and, at the same time, a concentration of a reducing agent rises, the nitrogen oxide (NOx) absorbed in the storage-reduction NOx catalyst is reduced and purified while being emitted based on the mechanism shown in Fig. 2 as described above.

[0179] Therefore, the air-fuel ratio of the exhaust gas flowing into the storage-reduction NOx catalyst is turned into a stoichiometric air-fuel ratio or a rich air-fuel ratio, whereby it becomes possible to reduce the nitrogen oxide (NOx) occluded in the storage-reduction NOx catalyst while emitting it.

[0180] Incidentally, an ability for occluding NOx of a storage-reduction NOx catalyst is limited. Therefore, when exhaust gas of a lean air-fuel ratio flows into the storage-reduction NOx catalyst for a long period, the ability for occluding NOx of the storage-reduction NOx catalyst saturates, and nitrogen oxide (NOx) in the exhaust gas is emitted in to the atmosphere without being removed or purified in the storage-reduction NOx catalyst.

[0181] However, in a diesel engine such as the internal combustion engine 1, air-fuel mixture of a lean air-fuel ratio is burnt in most of operating areas and an air-fuel ratio of exhaust gas turns into the lean air-fuel ratio in most of the operating areas accordingly. Thus, the ability for occluding NOx of the storage-reduction NOx catalyst tends to saturate.

[0182] Therefore, if an storage-reduction NOx catalyst is applied to a lean burn internal combustion engine such as a diesel engine, an air-fuel ratio of exhaust gas needs to be turned into a stoichiometric air-fuel ratio or a rich air-fuel ratio at a predetermined timing before a ability for occluding NOx of the storage-reduction NOx catalyst saturates.

[0183] In order to cope with this problem, the internal combustion engine 1 in accordance with this embodiment is provided with a reducing agent supplying mechanism for adding fuel (light oil) being an reducing agent in exhaust gas flowing in an exhaust passage in the upstream of the storage-reduction NOx catalyst.

[0184] The reducing agent supplying mechanism is one embodiment of adding means in accordance with the present invention. As shown in Fig. 5, its injection hole is attached to a cylinder head of the internal combustion engine 1 to face inside the exhaust branch line 18, and the reducing agent supplying mechanism is provided with a reducing agent injection valve 28 that opens and injects fuel when fuel of a predetermined opening pressure or more is applied, a reducing agent supplying path 29 that guides the fuel discharged from the fuel pump 6 to the reducing agent injection valve 28, a flow rate adjusting valve 30 that is provided in the middle of the reducing agent supplying path 29 and adjusts a flow rate of fuel flowing in the reducing agent supplying path 29, a shutoff valve 31 that is provided in the reducing agent supplying path 29 in the upstream of the flow rate adjusting valve 30 and blocks flow of fuel in the reducing

agent supplying path 29 and a reducing agent pressure sensor 32 that is attached to the reducing agent supplying path 29 in the upstream of the flow rate adjusting valve 30 and outputs an electric signal corresponding to a pressure in the reducing agent supplying path 29.

[0185] Further, the reducing agent injection valve 28 is preferably attached to a cylinder head such that the injection hole of the reducing agent injection valve 28 protrudes into an exhaust port of the cylinder 2 that is in the downstream of a connection part with the EGR passage 25 in the exhaust branch line 18 and closest to a gathering part of four branch lines in the exhaust branch line 18, and faces the gathering part of the exhaust branch line 18.

[0186] This is because a reducing agent (unburnt fuel component) injected from the reducing agent injection valve 28 is prevented from flowing into the EGR passage 25, and the reducing agent reaches the turbine housing 15b of the centrifugal supercharger without piling up in the exhaust branch line 18.

[0187] Further, in the example shown in Fig. 5, since the number 4 (#4) cylinder 2 among the four cylinders 2 of the internal combustion engine 1 is in the position closest to the gathering part of the exhaust branch line 18, the reducing agent injection valve 28 is attached to the exhaust port of the number 4 (#4) cylinder 2. If the cylinder 2 other than the number 4 (#4) cylinder 2 is in the position closest to the gathering part of the exhaust branch line 18, the reducing agent injection valve 28 is attached to the exhaust port of the cylinder 2.

[0188] In addition, the reducing agent injection valve 28 may be attached penetrating through a not-shown water jacket formed in the cylinder head or in the proximity of the water jacket to cool the reducing agent injection valve 28 utilizing cooling water flowing in the water jacket.

[0189] In such a reducing agent supplying mechanism, when the flow rate adjusting valve 30 is opened, a pressure of high pressure fuel discharged from the fuel pump 6 is applied to the reducing agent injection valve 28 via the reducing agent supplying path 29. Then, when a pressure of the fuel applied to the reducing agent injection valve 28 reaches a valve opening pressure or more, the reducing agent injection valve 28 is opened and the fuel as a reducing agent is injected in the exhaust branch line 18.

[0190] The reducing agent injected from the reducing agent injection valve 28 to the exhaust branch line 18 flows into the turbine housing 15b together with the exhaust gas flowing from the upstream of the exhaust branch line 18. The exhaust gas and the reducing agent having flown in the turbine housing 15b are agitated by the rotation of the turbine wheel and equally mixed to form exhaust gas of a rich air-fuel ratio.

[0191] The exhaust gas of the rich air-fuel ratio formed in this way flows into the particulate filter 20 from the turbine housing 15b via the exhaust pipe 19 and reduces the nitrogen oxide (NOx) occluded in the storage-reduc-

tion NOx catalyst of the particulate filter 20 into nitrogen (N₂) while emitting the nitrogen oxide (NOx).

[0192] Thereafter, when the flow rate adjusting valve 30 is closed and the supply of the reducing agent from the fuel pump 6 to the reducing agent injection valve 28 is blocked, the pressure of the fuel applied to the reducing agent injection valve 28 falls to less than the valve opening pressure. As a result, the reducing agent injection valve 28 is closed, and the addition of the reducing agent in the exhaust branch line 18 is stopped.

[0193] An electronic control unit (ECU) 35 for controlling the internal combustion engine 1 is also provided in the internal combustion engine 1 configured as above. This ECU 35 is a unit for controlling an operation state of the internal combustion engine 1 according to an operation condition of the internal combustion engine 1 or a request of an operator.

[0194] Various sensors such as a common rail pressure sensor 4a, an air flow meter 11, an intake gas temperature sensor 12, an intake pipe pressure sensor 17, an air-fuel ratio sensor 23, an exhaust gas temperature sensor 24, a reducing agent pressure sensor 32, a crank position sensor 33, a water temperature sensor 34, and an acceleration pedal opening degree sensor 36 are connected to the ECU 35 via electric wiring, and output signals of the various sensors are inputted to the ECU 35.

[0195] On the other hand, a fuel injection valve 3, an intake throttle actuator 14, an exhaust throttle actuator 22, an EGR valve 26, a flow rate adjusting valve 30, a shutoff valve 31 and the like are connected to the ECU 35 via electric wiring, and these portions are controlled by the ECU 35.

[0196] Here, the ECU 35 is provided with a CPU 351, an ROM 352, an RAM 353, a backup RAM 354, an input port 356 and an output port 357 that are connected each other by a bidirectional bus 350 and is also provided with an A/D converter (A/D) 355 connected to the input port 356 as shown in Fig. 7.

[0197] The input port 356 inputs an output signal of a sensor for outputting a signal of a digital signal format such as the crank position sensor 33 and transmits the output signal to the CPU 351 and the RAM 353.

[0198] The input port 356 inputs an output signal of a sensor for outputting a signal of an analogue signal format such as the common rail pressure sensor 4a, the air flow meter 11, the intake gas temperature sensor 12, the intake pipe pressure sensor 17, the air-fuel ratio sensor 23, the exhaust gas temperature sensor 24, the reducing agent pressure sensor 32, the water temperature sensor 34 and the acceleration pedal opening degree sensor 36 via the A/D 355 and transmits the output signal to the CPU 351 and the RAM 353.

[0199] The output port 357 is connected to the fuel injection valve 3, the intake throttle actuator 14, the exhaust throttle actuator 22, the EGR valve 26, the flow rate adjusting valve 30, the shutoff valve 31 and the like via electric wiring and transmits a control signal output-

ted from the CPU 351 to the fuel injection valve 3, the intake throttle actuator 14, the exhaust throttle actuator 22, the EGR valve 26, the flow rate adjusting valve 30 or the shutoff valve 31.

[0200] The ROM 352 stores a poisoning elimination control routine for eliminating poisoning of the particulate filter 20 in addition to various application programs such as a fuel injection control routine for controlling the fuel injection valve 3, an intake throttle control routine for controlling the intake throttle valve 13, an exhaust throttle control routine for controlling the intake throttle valve 21, an EGR control routine for controlling the EGR valve 26, a reducing agent addition control routine for controlling the flow rate adjusting valve 30 and a shutoff valve control routine for controlling the shutoff valve 31.

[0201] The ROM 352 stores various control maps in addition to the above-mentioned application programs. The control maps are, for example, a fuel injection amount control map showing a relation between an operation state of the internal combustion engine 1 and a basic fuel injection amount (basic fuel injection time), a fuel injection timing control map showing a relation between the operation state of the internal combustion engine 1 and a basic fuel injection timing, an intake throttle valve opening degree control map showing a relation between the operation state of the internal combustion engine 1 and a target opening degree of the intake throttle valve 13, an exhaust throttle valve opening degree control map showing a relation between the operation state of the internal combustion engine 1 and a target opening degree of the exhaust throttle valve 21, an EGR valve opening degree control map showing a relation between the operation state of the internal combustion engine 1 and a target opening degree of the EGR valve 26, a flow rate adjusting valve control map showing a relation between the operation state of the internal combustion engine 1 and an opening timing of the flow rate adjusting valve 30 and a shutoff valve control map showing a relation between the operation state of the internal combustion engine 1 and opening and closing timings of the shutoff valve 31.

[0202] The RAM 353 stores an output signal from each sensor, an operation result of the CPU 351 or the like. The operation result is, for example, a number of engine rotations that is calculated based on a time interval for the crank position sensor 33 outputting pulse signals. The data is rewritten with latest data each time the crank position sensor 33 outputs a pulse signal.

[0203] The backup RAM 354 is a nonvolatile memory that can store data even after the operation of the internal combustion engine 1 stops.

[0204] The CPU 351 operates in accordance with the application programs stored in the ROM 352 and executes poisoning elimination control, which is the point of the present invention, in addition to fuel injection control, intake throttle control, exhaust throttle control, EGR control, reducing agent addition control and shutoff valve control.

[0205] For example, in the fuel injection control, the CPU 351 first determines a fuel amount to be injected from the fuel injection valve 3 and then determines a timing for injecting fuel from the fuel injection valve 3.

[0206] In determining a fuel injection amount, the CPU 351 reads a number of engine rotations and an output signal (acceleration pedal opening degree) of the acceleration pedal opening sensor 36 that are stored in the RAM 353. The CPU 351 accesses to the fuel injection amount control map and calculates a basic fuel injection amount (basic fuel injection time) corresponding to the number of engine rotations and the acceleration pedal opening degree. The CPU 351 corrects the basic fuel injection time based on output signal values or the like of the air flow meter 11, the intake gas temperature sensor 12, the water temperature sensor 34 or the like and determines a final fuel injection time.

[0207] In determining a fuel injection timing, the CPU 351 accesses to the fuel injection timing control map and calculates a basic fuel injection timing corresponding to the number of engine rotations and the acceleration pedal opening degree. The CPU 351 corrects the basic fuel injection timing with output signal values of the air flow meter 11, the intake temperature sensor 12, the water temperature sensor 34 or the like as parameters and determines a final fuel injection timing.

[0208] When the fuel injection time and the fuel injection timing are determined, the CPU 351 compares the fuel injection timing and the output signal of the crank position sensor 33 and starts application of driving power to the fuel injection valve 3 at a point when the output signal of the crank position sensor 33 and the fuel injection timing coincide with each other. The CPU 351 stops the application of driving power to the fuel injection valve 3 at a point when a time elapsed from the point when the application of the driving power to the fuel injection valve 3 is started reaches the fuel injection time.

[0209] In addition, in the intake throttle control, the CPU 351 reads, for example, a number of engine rotations and an acceleration pedal opening degree that are stored in the RAM 353. The CPU 351 accesses to the intake throttle valve opening degree control map and calculates a target intake throttle valve opening degree corresponding to the number of engine rotations and the acceleration pedal opening degree. The CPU 351 applies driving power corresponding to the target intake throttle valve opening degree to the intake throttle actuator 14.

[0210] In doing so, the CPU 351 may detect an actual opening degree of the intake throttle valve 13 to apply feedback control to the intake throttle actuator 14 based on a difference between the actual opening degree of the intake throttle valve 13 and the target intake throttle valve opening degree.

[0211] In addition, in the exhaust throttle control, the CPU 351 controls the exhaust throttle actuator 22 in order to drive the exhaust throttle valve 21 in the valve closing direction in such cases that the internal combustion

engine 1 is in a warm-up state after a cold start or a cabin heater is in an actuated state.

[0212] In this case, loading on the internal combustion engine 1 increases, and the fuel injection amount is increased accordingly. As a result, a heating value of the internal combustion engine 1 increases and the warm-up of the internal combustion engine 1 is prompted or a heat source of the cabin heater is secured.

[0213] In addition, in the EGR control, the CPU 351 reads a number of engine rotations, an acceleration pedal opening degree, an output signal (cooling water temperature) of the water temperature sensor 34 or the like that are stored in the RAM 353 and determines whether or not a condition for executing the EGR control have been met.

[0214] The condition for executing the EGR control is that, for example, a cooling water temperature is a predetermined temperature or more, the internal combustion engine 1 has been operated for a predetermined time or more from the starting time or a variable amount of the acceleration pedal opening degree is a positive value.

[0215] If it is determined that the above-mentioned condition for executing the EGR control has been met, the CPU 351 accesses to the EGR valve opening degree control map and calculates a target EGR valve opening degree corresponding to the number of engine rotation and the acceleration pedal opening degree. The CPU 351 applies driving power corresponding to the target EGR valve opening degree to the EGR valve 26. On the other hand, if it is determined that the above-mentioned condition for executing the EGR control has not been met, the CPU 351 controls the EGR valve 26 in order to hold it in a fully closed state.

[0216] Moreover, in the EGR control, the CPU 351 may perform a so-called EGR valve feedback control for applying feedback control to an opening degree of the EGR valve 26 with an intake air amount of the internal combustion engine 1 as a parameter.

[0217] In the EGR valve feedback control, for example, the CPU 351 determines a target intake air amount with an acceleration pedal opening degree, a number of engine rotations or the like as a parameter. In doing so, a relation among an acceleration pedal opening degree, a number of engine rotations and a target intake air amount may be mapped in advance to calculate a target intake air amount from the map, an acceleration pedal opening degree and the number of engine rotations.

[0218] When a target intake air amount is determined by the above-mentioned procedures, the CPU 351 reads an output signal value (actual intake air amount) of the air flow meter 11 stored in the RAM 353 and compares the actual intake air amount and the target intake air amount.

[0219] If the actual intake air amount is less than the target intake air amount, the CPU 351 closes the EGR valve 26 by a predetermined degree. In this case, an amount of EGR gas flowing into the intake branch line

8 from the EGR passage 25 decreases, and an amount of EGR gas inhaled in the cylinder 2 of the internal combustion engine 1 decreases accordingly. As a result, an amount of fresh air inhaled in the cylinder 2 of the internal combustion engine 1 increases by the decreased amount of the EGR gas.

[0220] On the other hand, if the actual intake air amount is more than the target intake air amount, the CPU 351 opens the EGR valve 26 by a predetermined degree. In this case, an amount of EGR gas flowing into the intake branch line 8 from the EGR passage 25 increases, and an amount of EGR gas inhaled in the cylinder 2 of the internal combustion engine 1 increases accordingly. As a result, an amount of fresh air inhaled in the cylinder 2 of the internal combustion engine decreases by the increased amount of EGR gas.

[0221] In addition, in the reducing agent addition control, the CPU 351 first determines whether or not a condition for adding a reducing agent has been met. The condition for adding a reducing agent is that, for example, an storage-reduction NOx catalyst is in an active state, an output signal value (exhaust gas temperature) of the exhaust gas temperature sensor 24 is a predetermined upper limit value or less, or poisoning elimination control has not been executed in order to recover from SOx poisoning of the storage-reduction NOx catalyst, PM poisoning of the particulate filter 20 or the like.

[0222] If it is determined that the above-mentioned condition for adding a reducing agent has been met, the CPU 351 controls the flow rate adjusting valve 30 such that an air-fuel ratio of exhaust gas flowing into the storage-reduction NOx catalyst turns into a stoichiometric air-fuel ratio or a rich air-fuel ratio in a relatively short period and in a spike-like manner. Thereby nitrogen oxide (NOx) occluded in the storage-reduction NOx catalyst is emitted and reduced in a short period.

[0223] In doing so, the CPU 351 reads a number of engine rotations, an acceleration pedal opening degree, an intake air amount, a fuel injection amount (fuel injection time) or the like. The CPU 351 accesses to the flow rate adjusting valve control map of the ROM 352 and calculates a valve opening timing of the flow rate adjusting valve 30 corresponding to the number of engine rotations, the acceleration pedal opening degree, the intake air amount and the fuel injection amount. The CPU 351 opens the flow rate adjusting valve 30 in accordance with the valve opening timing.

[0224] In this case, high pressure fuel discharged from the fuel pump 6 is supplied to the reducing agent injection valve 28 via the reducing agent supply path 29, whereby a pressure of the fuel applied to the reducing agent injection valve 28 rises. Then, when the pressure of the fuel applied to the reducing agent injection valve 28 reaches the valve opening pressure or more, the reducing agent injection valve 28 is opened and the fuel as a reducing agent is injected into the exhaust branch line 18.

[0225] The reducing agent injected into the exhaust

branch line 18 from the reducing agent injection valve 28 mixes with exhaust gas flowing from the upstream of the exhaust branch line 18 to form exhaust gas of a stoichiometric air-fuel ratio or a rich air-fuel ratio. The exhaust gas of a stoichiometric air-fuel ratio or a rich air fuel ratio flows into the storage-reduction NOx catalyst.

[0226] In this way, when exhaust gas of a stoichiometric air-fuel ratio or a rich air-fuel ratio flows into an storage-reduction NOx catalyst, nitrogen oxide (NOx) occluded in the storage-reduction NOx catalyst is reduced to nitrogen (N₂) or the like while being emitted.

[0227] A poisoning elimination control, which is the point of the present invention, will now be described.

[0228] The particulate filter 20 on which a storage-reduction NOx catalyst is carried is disposed in an exhaust system of the internal combustion engine 1 in accordance with this embodiment. Since a ability of collecting PMs of the particulate filter 20 is limited, when particulate matters exceeding the ability of collecting PMs are collected in the particulate filter 20, an exhaust passage in the particulate filter 20 is clogged, which causes a trouble such as excessive increase of a exhaust pressure, that is, so-called PM poisoning occurs.

[0229] In addition, fuel of the internal combustion engine 1 may contain a sulfur (S) component. When such fuel is burnt in the internal combustion engine 1, the sulfur (S) component in the fuel is oxidized to form sulfur oxide (SOx) such as SO₂ and SO₃. Thus, exhaust gas of the internal combustion engine 1 contains the sulfur oxide (SOx).

[0230] When the exhaust gas containing the sulfur oxide (SOx) flows into the particulate filter 20, the sulfur oxide (SOx) is absorbed in the storage-reduction NOx catalyst by a mechanism similar to that for nitrogen oxide (NOx). The sulfur oxide (SOx) absorbed in the storage-reduction NOx catalyst forms stable barium sulfate (BaSO₄) as time passes. Thus, the sulfur oxide is hard to be decomposed and emitted simply by reducing an oxygen concentration of exhaust gas flowing into the storage-reduction NOx catalyst and tends to be accumulated in the storage-reduction NOx catalyst.

[0231] Then, when the accumulated amount of SOx in the storage-reduction NOx catalyst increases, an ability for absorbing NOx of the storage-reduction NOx catalyst falls, and nitrogen oxide (NOx) in the exhaust gas cannot be sufficiently removed. That is, so-called SOx poisoning occurs.

[0232] Therefore, it is necessary to eliminate the PM poisoning of the particulate filter 20 before the exhaust pressure excessively increases and also eliminate the SOx poisoning of the storage-reduction NOx catalyst before the ability of absorbing NOx of the storage-reduction NOx catalyst excessively falls.

[0233] A method of eliminating the PM poisoning of the particulate filter 20 can be exemplified by a method of raising a temperature of the particulate filter 20 up to a high temperature area of approximately 500 °C to 700 °C and turning an air-fuel ratio of exhaust gas flowing

into the particulate filter 20 into a lean air-fuel ratio, thereby oxidizing (burning) the particulate matters (PMs).

[0234] On the other hand, a method of eliminating the SOx poisoning of an storage-reduction NOx catalyst can be exemplified by a method of raising a temperature of the storage-reduction NOx catalyst up to a high temperature area of approximately 500 °C to 700 °C and turning an air-fuel ratio of exhaust gas flowing into the storage-reduction NOx catalyst into a rich air-fuel ratio, thereby thermally decomposing barium sulfate (BaSO₄) absorbed in the storage-reduction NOx catalyst into SO₃ or SO₄, and then causing SO₃ or SO₄ to react with hydrocarbon (HC) or carbon dioxide (CO) in the exhaust gas to reduce it into SO₂ of a gas form.

[0235] As described above, if the SOx poisoning and the PM poisoning of the particulate filter 20 are eliminated, it is necessary to raise a temperature of the particulate filter 20 up to a high temperature area of 500 °C or more. Thus, it is possible to perform SOx poisoning elimination processing and PM poisoning elimination processing at the time of a high load and high-speed rotation operation when an exhaust gas temperature of the internal combustion engine 1 rises. However, when the internal combustion engine 1 is in the state of a high load and high-speed rotation operation, an amount of exhaust gas emitted from the internal combustion engine in a unit of time increases. Thus, there is a problem in that a large amount of fuel corresponding to the emission amount is necessary for turning an air-fuel ratio of the emission into a rich air-fuel ratio in order to eliminate the SOx poisoning, which causes increase of a fuel consumption amount.

[0236] In order to cope with the problem, it is possible to eliminate the SOx poisoning by heating the particulate filter 20 and controlling an air-fuel ratio of exhaust gas flowing into the particulate filter 20 to a side richer than a stoichiometric air-fuel ratio. However, when the internal combustion engine 1 is in an idling operation state, there is a problem in that a flow rate of exhaust gas emitted from the internal combustion engine 1 in a unit time, in other words, a flow rate of exhaust gas flowing into the particulate filter 20 in a unit time decreases, and an amount of a reducing agent supplied to the particulate filter 20 also decreases accordingly, thus it takes long to eliminate the SOx poisoning.

[0237] In order to cope with the above-mentioned various problems, in poisoning elimination control in accordance with this embodiment, when necessity for eliminating the PM poisoning of the particulate filter 20 arises, SOx poisoning elimination processing of an storage-reduction NOx catalyst is executed in addition to PM poisoning elimination processing of the particulate filter 20 on condition that a decelerating operation state of the internal combustion engine 1 has been detected.

[0238] That is, when necessity for eliminating the PM poisoning of the particulate filter 20 arises, the CPU 351 executes the PM poisoning elimination processing of

the particulate filter 20 and the SOx poisoning elimination processing of the storage-reduction NOx catalyst with the fact that the operation state of the internal combustion engine 1 has shifted from a normal operation state or an acceleration operation state to the decelerating operation state as a trigger.

[0239] More specifically, as shown in Fig. 8, when an acceleration pedal opening degree (acceleration pedal position) is fully open (acceleration pedal position is 0%) and the operation state of the internal combustion engine 1 shifts to the decelerating operation state, the CPU 351 first causes the fuel injection valve 3 to post-inject secondary fuel at an expanding stroke of each cylinder 2 and also causes the reducing agent injection valve 28 to add fuel in the exhaust gas to increase bed temperatures of the particulate filter 20 and the storage-reduction NOx catalyst.

[0240] In doing so, the CPU 351 may apply feedback control to an amount of post-injection fuel and an amount of added fuel based on an output signal value of the exhaust gas temperature sensor 24 in order to prevent excessive increase of the bed temperatures of the particulate filter 20 and the storage-reduction NOx catalyst.

[0241] Subsequently, the CPU 351 executes the SOx poisoning elimination processing (SOx poisoning recovery operation) of the storage-reduction NOx catalyst for a first predetermined time. In the SOx poisoning elimination processing, the CPU 351 controls an amount of post-injection fuel from the fuel injection valve 3 and an amount of added fuel from the reducing agent injection valve 28 in order to turn an air-fuel ratio of exhaust gas flowing into the particulate filter 20 into a rich air-fuel ratio. In doing so, the CPU 351 may apply feedback control to the amount of post-injection fuel and the amount of added fuel based on an output signal of the air-fuel ratio sensor 35.

[0242] Moreover, the CPU 351 executes the PM poisoning elimination processing (PM poisoning recovery operation) of the particulate filter 20 for a second predetermined time after the first predetermined time has elapsed. In the PM poisoning elimination processing, the CPU 351 controls the amount of post-injection fuel and the amount of added fuel such that an air-fuel ratio of exhaust gas flowing into the particulate filter turns into a weakly lean air-fuel ratio.

[0243] The CPU 351 ends the post-injection from the fuel injection valve 3 and the addition of fuel from the reducing agent injection valve 28 after the second predetermined time has elapsed.

[0244] Here, the first predetermined time and the second predetermined time may be fixed values set in advance or variable values that are changed according to an operation history of the internal combustion engine 1.

[0245] Further, in general, when the internal combustion engine 1 is in the decelerating operation state, if a predetermined fuel-cut condition is met, injection of main fuel from the fuel injection valve 3 is prohibited,

that is, so-called decelerating fuel-cut control is executed. However, it is preferable to prohibit execution of the decelerating fuel-cut control while the above-mentioned SOx poisoning elimination processing and PM poisoning elimination processing are executed.

[0246] This is because, when the decelerating fuel-cut control is executed while the SOx poisoning elimination processing and the PM poisoning elimination processing are executed, low temperature fresh air inhaled in the internal combustion engine 1 is emitted as exhaust gas without change, thus, the particulate filter 20 and the storage-reduction NOx catalyst are unnecessarily cooled by the low temperature exhaust gas.

[0247] In addition, in the above-mentioned SOx poisoning elimination processing and PM poisoning elimination processing, the CPU 351 preferably controls the EGR valve 26 to increase its opening degree and the intake throttle valve 13 to decrease its opening degree.

[0248] This is because the CPU 351 reduces an amount of fresh air inhaled in the internal combustion engine 1, thereby suppressing increase of the amount of post-injection fuel and the amount of added fuel and also suppressing fall of an exhaust air temperature due to low temperature fresh air.

[0249] In this way, when the PM poisoning elimination processing and the SOx poisoning elimination processing are executed on condition that a decelerating operation state of the internal combustion engine 1 has been detected, the PM poisoning elimination processing and the SOx poisoning elimination processing are executed not only in the decelerating operation period of the internal combustion engine 1 but also from the decelerating operation period to an idling operation period if the internal combustion engine 1 shifts to an idling operation state subsequently to the decelerating operation state. Thus, it becomes possible to sufficiently secure a period for executing the PM poisoning elimination processing and the SOx poisoning elimination processing.

[0250] The poisoning elimination control in accordance with this embodiment will now be hereinafter described specifically.

[0251] In the poisoning elimination control, the CPU 351 executes a poisoning elimination control routine shown in Fig. 9. This poisoning elimination control routine is a routine that is stored in the ROM 352 in advance and repeatedly executed at each predetermined time (e.g., each time the crank position sensor 33 outputs a pulse signal) by the CPU 351.

[0252] In the poisoning elimination control routine, the CPU 351 first detects an exhaust pressure P_x acting on the internal combustion engine 1 in step S601. Since the exhaust pressure P_x varies according to a number of engine rotations of the internal combustion engine 1 and an opening degree of the intake throttle valve 13, the number of engine rotations and the opening degree of the intake throttle valve 13 may be estimated as parameters.

[0253] In step S602, the CPU 351 determines wheth-

er or not a value found by subtracting a reference exhaust pressure P_{x0} from the exhaust pressure P_x detected in step S601 ($P_x - P_{x0}$) is larger than a predetermined value P_s . The reference exhaust pressure P_{x0} is an exhaust pressure under a condition identical with the exhaust pressure P_x (e.g., a number of engine rotations and an opening degree of the intake throttle valve 13 are identical) and at the time when particulate matters (PMs) are not collected in the particulate filter 20. The reference exhaust pressure P_{x0} is experimentally found and stored in the ROM 352 in advance.

[0254] If it is determined in step S602 that the value ($P_x - P_{x0}$) found by subtracting the reference exhaust pressure P_{x0} from the exhaust pressure P_x is the predetermined value P_s or less, the CPU 351 regards that a degree of the PM poisoning of the particulate filter 20 is within an allowable range and ends the execution of this routine at this point.

[0255] On the other hand, if it is determined in step S602 that the value ($P_x - P_{x0}$) found by subtracting the reference exhaust pressure P_{x0} from the exhaust pressure P_x is larger than the predetermined value P_s , the CPU 351 regards that a degree of the PM poisoning of the particulate filter 20 exceeds the allowable range and advances to step S603.

[0256] In step S603, the CPU 351 determines whether or not the operation state of the internal combustion engine 1 is in the decelerating operation state or the idling operation state.

[0257] If it is determined in step S603 that the operation state of the internal combustion engine 1 is neither in the decelerating operation state nor the idling operation state, the CPU 351 ends the execution of this routine at this point.

[0258] If it is determined in step S603 that the operation state of the internal combustion engine 1 is in the decelerating operation state or the idling operation state, the CPU 351 advances to step S604. In step S604, the CPU 351 accesses to a SOx poisoning elimination flag storing area that is set in the RAM 353 in advance and determines whether or not "1" is stored in the SOx poisoning elimination flag storing area.

[0259] The SOx poisoning elimination flag storing area is an area in which "1" is set when the execution of the SOx poisoning elimination processing ends and "0" is set when the execution of the PM poisoning elimination processing ends.

[0260] If it is determined in step S604 that "1" is not stored in the SOx poisoning elimination flag storing area, that is, if the execution of the SOx poisoning elimination processing has not ended, the CPU 351 advances to step S605 and executes the SOx poisoning elimination processing of the storage-reduction NOx catalyst.

[0261] In the SOx poisoning elimination processing, the CPU 351 first raises a temperature of exhaust gas by causing the fuel injection valve 3 to post-inject fuel at the time of the expansion stroke of each cylinder 2 as

mentioned in the description of Fig. 8, and also burns the fuel with the storage-reduction NOx catalyst by adding the fuel into the exhaust gas from the reducing agent injection valve 28, thereby raising bed temperatures of the particulate filter 20 and the storage-reduction NOx catalyst.

[0262] Subsequently, the CPU 351 applies feedback control to an amount of post-injection fuel and an amount of added fuel such that an air-fuel ratio of exhaust gas flowing into the storage-reduction NOx catalyst turns into a desired rich air-fuel ratio suitable for the SOx poisoning elimination, while referring to an output signal value of the air-fuel ratio sensor 35. Moreover, the CPU 351 increases an opening degree of the EGR valve 26 and also decreases an opening degree of the intake throttle valve 13 in order to decrease an amount of fresh air inhaled in the internal combustion engine 1.

[0263] In this case, an air-fuel ratio of exhaust gas flowing into the storage-reduction NOx catalyst under the conditions in which a bed temperature of the storage-reduction NOx catalyst rises turns into a rich air-fuel ratio. Thus, barium sulfate (BaSO_4) absorbed in the storage-reduction NOx catalyst is thermally decomposed into SO_3 - or SO_4 - and the SO_3 - or SO_4 - reacts with hydrocarbon (HC) or carbon dioxide (CO) in the exhaust gas to be reduced into SO_2 - of a gas form.

[0264] When the execution of the SOx poisoning elimination processing is started in step S605, the CPU 351 starts up a SOx poisoning elimination timer T_1 in step S606 and causes it to measure an execution time of the SOx poisoning elimination processing.

[0265] In step S607, the CPU 351 determines whether or not the time measured by the SOx poisoning elimination timer T_1 is a first predetermined time T_s , that is, whether or not the SOx poisoning elimination processing has been executed for the first predetermined time T_s or more.

[0266] If it is determined in step S607 that the time measured by the SOx poisoning elimination timer T_1 is less than the first predetermined time T_s , the CPU 351 returns to step S603 and determines whether or not the decelerating operation state or the idling operation state of the internal combustion engine 1 is continued. If it is determined in step S603 that the decelerating operation state or the idling operation state of the internal combustion engine 1 is continued, the CPU 351 executes again the processing of S604 and subsequent steps. If it is determined in step S603 that the internal combustion engine 1 is neither in the decelerating operation state nor the idling operation state, the CPU 351 advances to step S614. In step S614, the CPU 351 stops the execution of the SOx poisoning elimination processing and resets the time measured by the SOx poisoning elimination timer T_1 to "0" to end the execution of this routine.

[0267] On the other hand, if it is determined in step S607 that the time measured by the SOx poisoning elimination timer T_1 is the first predetermined time T_s or

more, that is, if it is determined that the execution time of the SOx poisoning elimination processing has reached the first predetermined time or more, the CPU 351 regards that the SOx poisoning of the storage-reduction NOx catalyst has been eliminated and advances to step S608.

[0268] In step S608, the CPU 351 accesses to the SOx poisoning elimination flag storing area of the RAM 353 and rewrites a value of the SOx poisoning elimination flag storing area from "0" to "1".

[0269] In step S609, the CPU 351 starts the execution of the PM poisoning elimination processing of the particulate filter 20. In the PM poisoning elimination processing, the CPU 351 controls an amount of post-injection fuel and an amount of added fuel such that an air-fuel ratio of exhaust gas flowing into the particulate filter 20 turns into a weakly lean air-fuel ratio while maintaining an opening degree of the EGR valve 26 and an opening degree of the intake throttle valve 13 at an opening degree similar to that in the above-mentioned SOx poisoning processing as mentioned in the description of Fig. 8.

[0270] In this case, the air-fuel ratio of the exhaust gas flowing into the particulate filter 20 turns into a weakly lean air-fuel ratio. Thus, an unburnt fuel component (e.g., hydrocarbon (HC)) remaining in the exhaust gas is burnt with the storage-reduction NOx catalyst, and a temperature of the particulate filter 20 is maintained high by heat generated then. When exhaust gas of a weakly lean air-fuel ratio flows into the particulate filter 20 under the conditions in which the temperature of the particulate filter 20 is maintained high in this way, the particulate matters (PMs) collected in the particulate filter 20 are oxidized (burnt).

[0271] When the execution of the PM poisoning elimination processing is started in step S609, the CPU 351 starts up a PM poisoning elimination timer T_2 in step S610 and causes it to measure an execution time of the PM poisoning elimination processing.

[0272] In step S611, the CPU 351 determines whether or not the time measured by the PM poisoning elimination timer T_2 is a second predetermined time T_p or more, that is, whether or not the SOx poisoning elimination processing has been executed for the second predetermined time or more.

[0273] If it is determined in step S611 that the time measured by the PM poisoning elimination timer T_2 is less than the second predetermined time T_p , the CPU 351 returns to step S603 and determines whether or not the decelerating operation state or the idling operation state of the internal combustion engine 1 is continued.

[0274] If it is determined in step S603 that the decelerating operation state or the idling operation state of the internal combustion engine 1 is continued, the CPU 351 executes the processing of S604 and subsequent steps again. In doing so, the CPU 351 determines in step S604 that "1" is stored in the SOx poisoning elimination flag storing area. Thus, the CPU 351 skips the

processing of steps S605 to S608 and executes the processing of step S609 and subsequent steps again.

[0275] If it is determined in step S603 that the internal combustion engine 1 is not in the decelerating operation state or the idling operation state, the CPU 351 advances to step S614. In step S614, the CPU 351 stops the execution of the PM poisoning elimination processing, resets the time measured by the PM poisoning elimination timer T_2 to "0" and also resets the value of the SOx poisoning elimination flag storing area to "0".

[0276] On the other hand, it is determined in step S611 that the time measured by the PM poisoning elimination timer T_2 is the second predetermined time T_p or more, that is, if it is determined that the execution time of the PM poisoning elimination processing has reached the second predetermined time T_p or more, the CPU 351 regards that the PM poisoning of the particulate filter 20 has been eliminated and advances to step S612.

[0277] In step S612, the CPU 351 ends the execution of the PM poisoning elimination processing. More specifically, the CPU 351 controls the fuel injection valve 3 in order to stop post-injection and also controls the flow rate adjusting valve 30 in order to stop addition of fuel from the reducing agent injection valve 28.

[0278] In step S613, the CPU 351 accesses to the SOx poisoning elimination flag storing area of the RAM 353 and rewrites a value of the SOx poisoning elimination flag storing area from "1" to "0". After executed the processing of step S613, The CPU 351 ends the execution of this routine.

[0279] In this way, the CPU 351 executes the poisoning elimination control routine, whereby the poisoning eliminating means in accordance with the present invention is realized.

[0280] In the above-mentioned embodiment, the SOx poisoning elimination processing and the PM poisoning elimination processing of a particulate filter on which a storage-reduction NOx catalyst is carried are executed when the internal combustion engine 1 is in a decelerating operation state and in an idling operation state. Thus, periods for executing the SOx poisoning elimination processing and the PM poisoning elimination processing become easily secured.

[0281] Moreover, in the exhaust gas purification device of the internal combustion engine in accordance with this embodiment, when the SOx poisoning elimination processing and the PM poisoning elimination processing are executed, an opening degree of the intake throttle valve 13 is decreased and an opening degree of the EGR valve 26 is increased to reduce a flow rate of exhaust gas emitted from the internal combustion engine 1 in a unit of time. Thus, amounts of post-injection fuel and added fuel that intend to turn an air-fuel ratio of exhaust gas into a rich air-fuel ratio can be reduced.

[0282] Therefore, according to the exhaust gas purification device of the internal combustion engine in accordance with this embodiment, it becomes possible to

eliminate the PM poisoning and the SOx poisoning of a particulate filter and an storage-reduction NOx catalyst while suppressing an increase of a fuel consumption amount required for eliminating the SOx poisoning and the PM poisoning.

<Fourth embodiment>

[0283] A fourth embodiment of the exhaust gas purification device of the internal combustion engine in accordance with the present invention will now be described with reference to Figs. 10 and 11. Here, a configuration that is different from that of the third embodiment will be described, and description of a similar configuration shall be omitted.

[0284] A difference between the third embodiment and this embodiment is that, when poisoning elimination processing of the particulate filter 20 and an storage-reduction NOx catalyst is performed, a deceleration torque is actively generated in this embodiment.

[0285] This assumes a case in which execution of decelerating fuel-cut control is prohibited when the poisoning elimination processing of the particulate filter 20 and the storage-reduction NOx catalyst is executed.

[0286] When the execution of the decelerating fuel-cut control is prohibited during the period for executing the poisoning elimination processing of the particulate filter 20 and the storage-reduction NOx catalyst, fuel is burnt in the internal combustion engine 1. Thus, a torque of the internal combustion engine 1 unnecessarily increases and, as a result, it is likely that a decelerating performance of an automobile declines.

[0287] On the other hand, in the case in which the execution of the decelerating fuel-cut control is prohibited and then the poisoning elimination processing of the particulate filter 20 and the storage-reduction NOx catalyst is performed, when a decelerating torque is generated, a torque increase of the internal combustion engine due to the prohibition of the execution of the decelerating fuel-cut control is offset by the decelerating torque, whereby the decelerating performance of an automobile never declines. As a result, it becomes possible to eliminate the poisoning of the particulate filter 20 and the storage-reduction NOx catalyst without reducing the decelerating performance of the automobile.

[0288] As methods of actively generating a decelerating torque when the poisoning elimination processing of the particulate filter 20 and the storage-reduction NOx catalyst is executed will now be described.

[0289] A method of generating a decelerating torque can be exemplified by a method of reducing a torque itself generated by the internal combustion engine 1, a method of increasing a braking force of a braking device provided in an automobile that is mounted with the internal combustion engine 1, a method of properly combining these two methods, or the like. Here, the method of reducing a torque itself generated by the internal combustion engine 1 will be described.

[0290] In the case in which a torque itself generated by the internal combustion engine 1 is reduced, the CPU 351 advances an injection timing of main fuel from the fuel injection valve 3 to before a dead point on a compressing stroke, preferably to the middle of the compressing stroke.

[0291] When the main fuel is injected in the middle of the compressing stroke, the fuel burns in the middle of the compressing stroke. Thus, a pressure in the cylinder 2 shows a maximum value (hereinafter referred to as a maximum pressure inside a cylinder) before the dead point on the compressing stroke as shown in Fig. 10.

[0292] In this case, the above-mentioned maximum pressure inside a cylinder prevents a rising operation of a not-shown piston in the cylinder 2. Therefore, the internal combustion engine 1 performs a negative work of raising the piston up to the dead point on the compressing stroke against the maximum pressure inside a cylinder.

[0293] As a result, even if the fuel is burnt in the internal combustion engine 1 due to the prohibition of the execution of the decelerating fuel-cut control, a torque of the internal combustion engine 1 never increases unnecessarily.

[0294] Incidentally, in the description of Fig. 9, the example in which main fuel is supplied into the cylinder 2 by one fuel injection is described. If the main fuel is supplied into the cylinder 2 by two fuel injections, for example, if a part of the main fuel that should be supplied into the cylinder 2 is injected in a pilot-like manner and the remaining main fuel is mainly injected at the point when the fuel pilot-injected is in an ignition state, the CPU 351 preferably advances both a timing of the pilot injection and a timing of a main injection to the middle of the compressing stroke as shown in Fig. 11.

[0295] In addition, if the injection of the main fuel is advanced in order to generate a decelerating torque, the CPU 351 may control the EGR valve 26 in order to increase an amount of exhaust gas (EGR gas) that is circulated from the exhaust branch line 18 to the intake branch line 8.

[0296] Here, the exhaust gas as the EGR gas contains an inactive gas component that does not burn itself like carbon dioxide (CO₂), water (H₂O) or the like and has endothermism. Thus, when the EGR gas is supplied into the cylinder 2, a combustion temperature in the cylinder 2 is lowered. As a result, the maximum pressure inside cylinder falls and it becomes easy to generate a deceleration torque.

[0297] In this way, in the exhaust gas purification device of the internal combustion engine in this embodiment, when the poisoning elimination processing of the particulate filter 20 and the storage-reduction NOx catalyst are executed, it becomes possible to suppress unnecessary increase of a torque of the internal combustion engine 1 even if the execution of the decelerating fuel-cut control is prohibited in order to suppress fall of temperatures of the particulate filter 20 and the storage-

reduction NOx catalyst. Thus, a decelerating performance of an automobile never declines.

[0298] Therefore, according to the exhaust gas purification device of the internal combustion engine in this embodiment, it becomes possible to preferably eliminate the poisoning of the particulate filter 20 and the storage-reduction NOx catalyst without reducing the decelerating performance of an automobile.

[0299] In the exhaust gas purification device of the internal combustion engine in accordance with the present invention, when necessity for eliminating poisoning by oxide of the particulate filter on which a NOx absorbing agent is carried or poisoning by particulate matters arises, the poisoning elimination processing of the particulate filter is executed on condition that the decelerating operation state of the internal combustion engine has been detected. Thus, the poisoning elimination processing is executed not only in a period when the internal combustion engine is in the decelerating operation state but also in the idling operation period if the internal combustion engine shifts from the decelerating operating state to the idling operation state, and it is easy to secure a period for executing the poisoning elimination processing.

[0300] Moreover, in the exhaust gas purification device of the internal combustion engine in accordance with the present invention, the elimination processing of the poisoning of a particulate filter on which a NOx absorbing agent is carried and the elimination processing of poisoning due to particulate matters are executed at the time of the decelerating operation with a relatively few amount of exhaust gas emitted from the internal combustion engine or at the time of the idling operation. Thus, it becomes possible to suppress increase of a fuel consumption amount in accordance with the poisoning elimination processing.

[0301] Therefore, according to the exhaust gas purification device of the internal combustion engine in accordance with the present invention, when necessity for eliminating the poisoning of the particulate filter on which a NOx absorbing agent is carried and the poisoning due to particulate matters arises, it becomes possible to surely eliminate the poisoning of the particulate filter while suppressing the increase of the fuel consumption amount in accordance with the poisoning elimination processing.

[0302] In addition, in the exhaust gas purification device of the internal combustion engine in accordance with the present invention, if decelerating torque generating means generates a desired decelerating torque when the poisoning elimination processing of a particulate filter is executed, a decline of a decelerating performance of an automobile mounted with an internal combustion engine can be suppressed even if combustion is performed in the internal combustion engine in order to suppress the fall of a temperature of the particulate filter.

[0303] Thus, it is seen that an exhaust gas purification

device for an internal combustion engine is provided. One skilled in the art will appreciate that the present invention can be practiced by other than the preferred embodiments which are presented for the purposes of illustration and not of limitation, and the present invention is limited only by the claims which follow.

[0304] An exhaust gas purification device of an internal combustion engine in accordance with the present invention is provided with a NOx absorbent, which is provided in an exhaust passage of the internal combustion engine, for occluding nitrogen oxide when an oxygen concentration of inflow exhaust gas is high and emitting the occluded nitrogen oxide when the oxygen concentration of the inflow exhaust gas falls, and poisoning eliminating means for, if necessity for eliminating poisoning of the NOx absorbent due to oxide arises, executing poisoning elimination processing of the NOx absorbent when the internal combustion engine is in a decelerating operation state and an idling operation state, and further provided with a particulate filter on which a NOx absorbent is carried and poisoning eliminating means for, if necessity for eliminating poisoning of the particulate filter due to oxide and/or due to particulate matters arises, executing poisoning elimination processing of the particulate filter on condition that a decelerating operation state of the internal combustion engine is detected.

Claims

1. An exhaust gas purification device of an internal combustion engine comprising:

an exhaust gas purification material, which is provided in an exhaust passage of said internal combustion engine, for absorbing harmful matters in exhaust gas when an oxygen concentration of inflow exhaust gas is high and emitting the absorbed harmful matters in exhaust gas when the oxygen concentration of the inflow exhaust gas falls; and

poisoning eliminating means for, if necessity for eliminating poisoning of said exhaust gas purification material due to oxide arises, executing poisoning elimination processing of said exhaust gas purification material when said internal combustion engine is in a decelerating operation state and an idling operation state.

2. An exhaust gas purification device of an internal combustion engine according to claim 1, wherein said exhaust gas purification material is a NOx absorbent for occluding nitrogen oxide when the oxygen concentration of the inflow exhaust gas is high and emitting the occluded nitrogen oxide when the oxygen concentration of the inflow exhaust gas falls,

and further comprising poisoning eliminating means by executing poisoning elimination processing of said NOx absorbent if necessity for eliminating poisoning of said NOx absorbent due to oxide arises.

3. An exhaust gas purification device of an internal combustion engine according to claim 2, wherein said poisoning eliminating means turns an air-fuel ratio of the exhaust gas flowing into said NOx absorbent into a stoichiometric air-fuel ratio or a rich air-fuel ratio to eliminate the poisoning of said NOx absorbent.

4. An exhaust gas purification device of an internal combustion engine comprising:

a NOx catalyst, which is provided in an exhaust passage of an internal combustion engine, for occluding nitrogen oxide when an oxygen concentration of inflow exhaust gas is high and reducing and purifying the occluded nitrogen oxide while emitting the same when the oxygen concentration of the inflow exhaust gas falls and a reducing agent exists;

reducing agent adding means for adding a reducing agent in an exhaust passage in more upstream than said NOx catalyst; and

poisoning eliminating means for, if necessity for eliminating poisoning of said NOx catalyst due to oxide arises, controlling said reducing agent adding means in order to eliminate the poisoning of said NOx catalyst when said internal combustion engine is in a decelerating operation state or an idling operation state.

5. An exhaust gas purification device of an internal combustion engine according to claim 4, wherein

under a situation in which it is necessary to eliminate poisoning of said NOx catalyst due to oxide, when said internal combustion engine is in the decelerating operation state or the idling operation state, said poisoning eliminating means controls said reducing agent adding means such that the air-fuel ratio of the exhaust gas flowing into said NOx catalyst turns into a stoichiometric air-fuel ratio or a rich air-fuel ratio, and when the internal combustion engine is neither in the decelerating operation state nor in the idling operation state, said poisoning eliminating means controls said reducing agent adding means such that the air-fuel ratio of the exhaust gas flowing into said NOx catalyst turns into a lean air-fuel ratio.

6. An exhaust gas purification device of an internal combustion engine according to claim 5, wherein when said internal combustion engine is continuously operated idly for a predetermined time or

more and then operated acceleratingly during the execution of the poisoning elimination processing, said poisoning eliminating means controls said reducing agent adding means in order to prohibit the addition of a reducing agent for a predetermined period from the start of the accelerating operation.

7. An exhaust gas purification device of an internal combustion engine according to claim 6, wherein said poisoning eliminating means determines said predetermined period based on a continuous time of the idling operation of said internal combustion engine.

8. An exhaust gas purification device of an internal combustion engine according to claim 5, wherein said poisoning eliminating means controls said reducing agent adding means in order to prohibit addition of a reducing agent when the continuous time of the idling operation of said internal combustion engine exceeds an upper limit value set in advance.

9. An exhaust gas purification device of an internal combustion engine according to claim 1, wherein

said exhaust gas purification material is a particulate filter for absorbing nitrogen oxide in exhaust gas when the oxygen concentration of the inflow exhaust gas is high and emitting the absorbed nitrogen oxide when the oxygen concentration of the inflow exhaust gas falls and, further comprising poisoning eliminating means for executing poisoning elimination processing of said particulate filter if necessity for eliminating poisoning of said particulate filter due to oxide and/or poisoning of said particulate filter due to particulate matters arises.

10. An exhaust gas purification device of an internal combustion engine according to claim 9, wherein when eliminating poisoning of said particulate filter due to oxide and particulate matters, said poisoning eliminating means turns an air-fuel ratio of exhaust gas flowing into said particulate filter into a rich air-fuel ratio for a first predetermined period and into a lean air-fuel ratio for a subsequent second predetermined period.

11. An exhaust gas purification device of an internal combustion engine according to claim 9, further comprising an exhaust gas re-circulating mechanism for re-circulating a part of exhaust gas flowing through the exhaust passage of said internal combustion engine to an intake passage, wherein said poisoning eliminating means controls said exhaust gas re-circulating mechanism in order to increase an exhaust gas amount to be re-circu-

lated from the exhaust passage to the intake passage when eliminating poisoning of said particulate filter due to oxide.

12. An exhaust gas purification device of an internal combustion engine according to claim 9, further comprising an intake throttle valve, which is provided in an intake passage of said internal combustion engine, for adjusting an intake flow rate of intake gas flowing in the intake passage, wherein said poisoning eliminating means reduces an opening degree of said intake throttle valve when eliminating poisoning of said particulate filter due to oxide.

13. An exhaust gas purification device of an internal combustion engine according to claim 9, further comprising:

an exhaust gas re-circulating mechanism for re-circulating a part of exhaust gas flowing in the exhaust passage of said internal combustion engine to the intake passage; and an intake throttle valve, which is provided in the intake passage of said internal combustion engine, for adjusting an intake flow rate flowing in the intake passage, wherein said poisoning eliminating means controls said exhaust gas re-circulating mechanism in order to increase an amount of exhaust gas to be re-circulated from the exhaust passage to the intake passage and reduces the opening degree of said intake throttle valve when eliminating the poisoning of said particulate filter due to oxide.

14. An exhaust gas purification device of an internal combustion engine according to claim 10, further comprising:

a fuel injection valve for directly injecting fuel into a cylinder of said internal combustion engine; and adding means for adding fuel in an intake passage in more upstream than said particulate filter, wherein said poisoning eliminating means controls a sub-injection amount from said fuel injection valve and/or an added amount from said adding means to control the air-fuel ratio of the exhaust gas.

15. An exhaust gas purification device of an internal combustion engine according to claim 9, further comprising decelerating torque generating means for generating a desired decelerating torque when the poisoning elimination processing of said particulate filter is executed.

16. An exhaust gas purification device of an internal combustion engine according to claim 15, wherein said decelerating torque generating means reduces a torque generated by said internal combustion engine. 5
17. An exhaust gas purification device of an internal combustion engine according to claim 16, wherein said decelerating torque generating means advances a fuel injection timing of said internal combustion engine. 10
18. An exhaust gas purification device of an internal combustion engine according to claim 16, further comprising an exhaust gas re-circulating mechanism for re-circulating a part of the exhaust gas flowing in the exhaust passage of said internal combustion engine to the intake passage, wherein said decelerating torque generating means advances the fuel injection timing of said internal combustion engine and increases an amount of exhaust gas to be re-circulated by said exhaust gas re-circulating mechanism. 15
20
19. An exhaust gas purification device of an internal combustion engine according to claim 17 or 18, further comprising: 25
- main fuel injecting means for injecting main fuel supplied for combustion into a cylinder of said internal combustion engine; and 30
- pilot injecting means for injecting secondary fuel prior to the injection of the main fuel by said main fuel injecting means, wherein said decelerating torque generating means advances the fuel injection timing of said main fuel injecting means and the fuel injection timing of said pilot injecting means. 35
20. An exhaust gas purification device of an internal combustion engine according to claim 15, wherein said decelerating torque generating means increases a braking force by a braking device of an automobile mounted with said internal combustion engine. 40
45

50

55

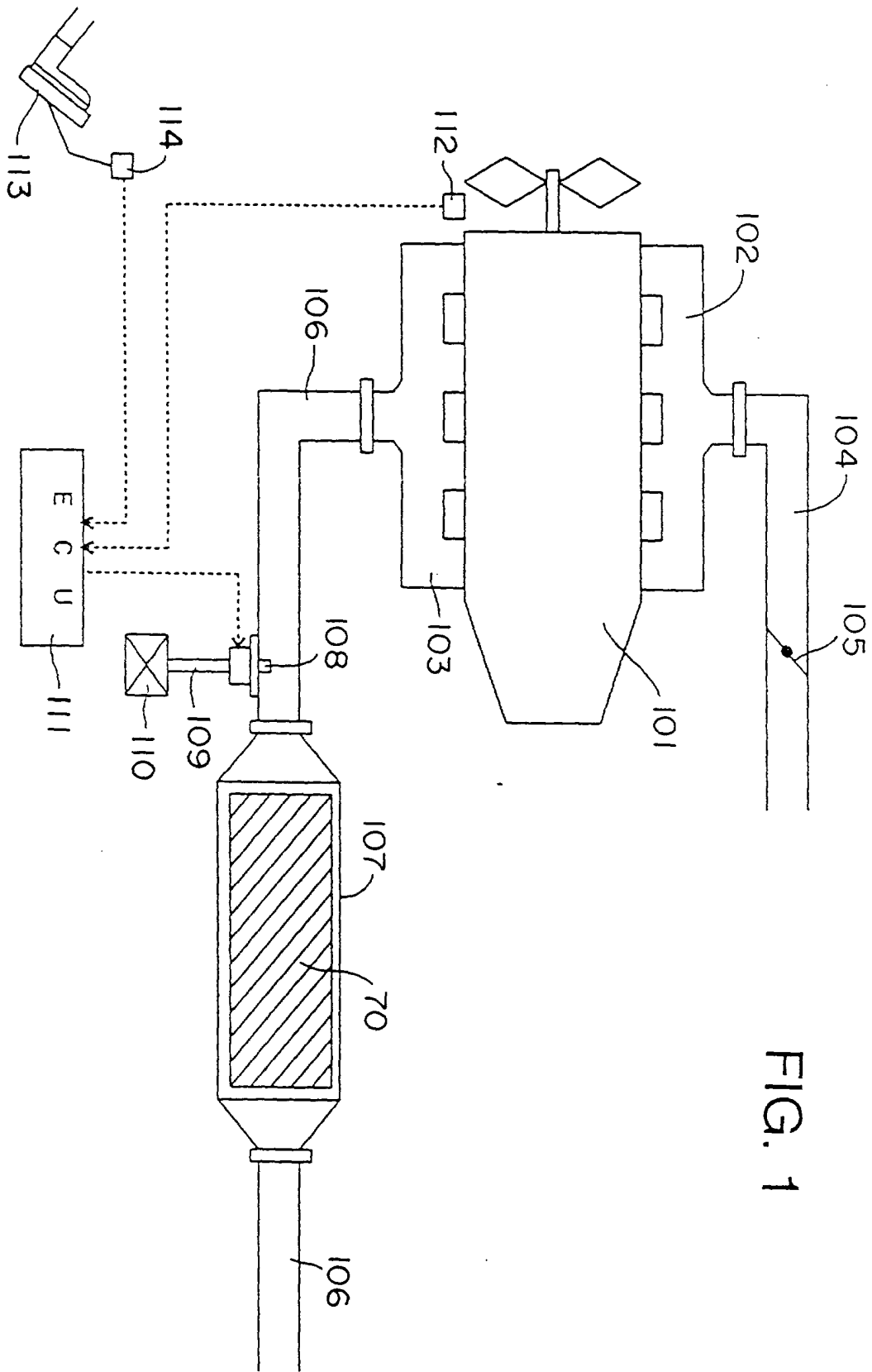

FIG. 1

FIG. 2

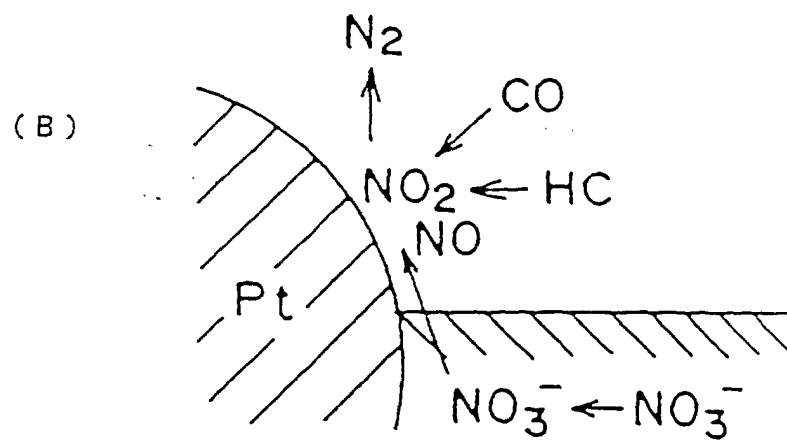
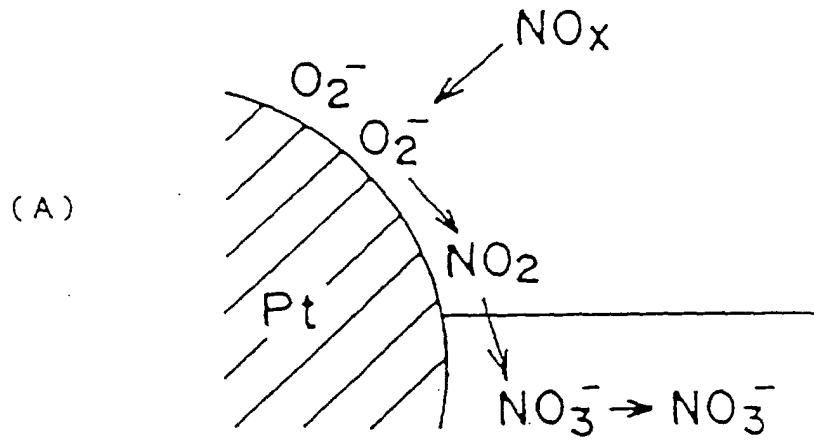

FIG. 3

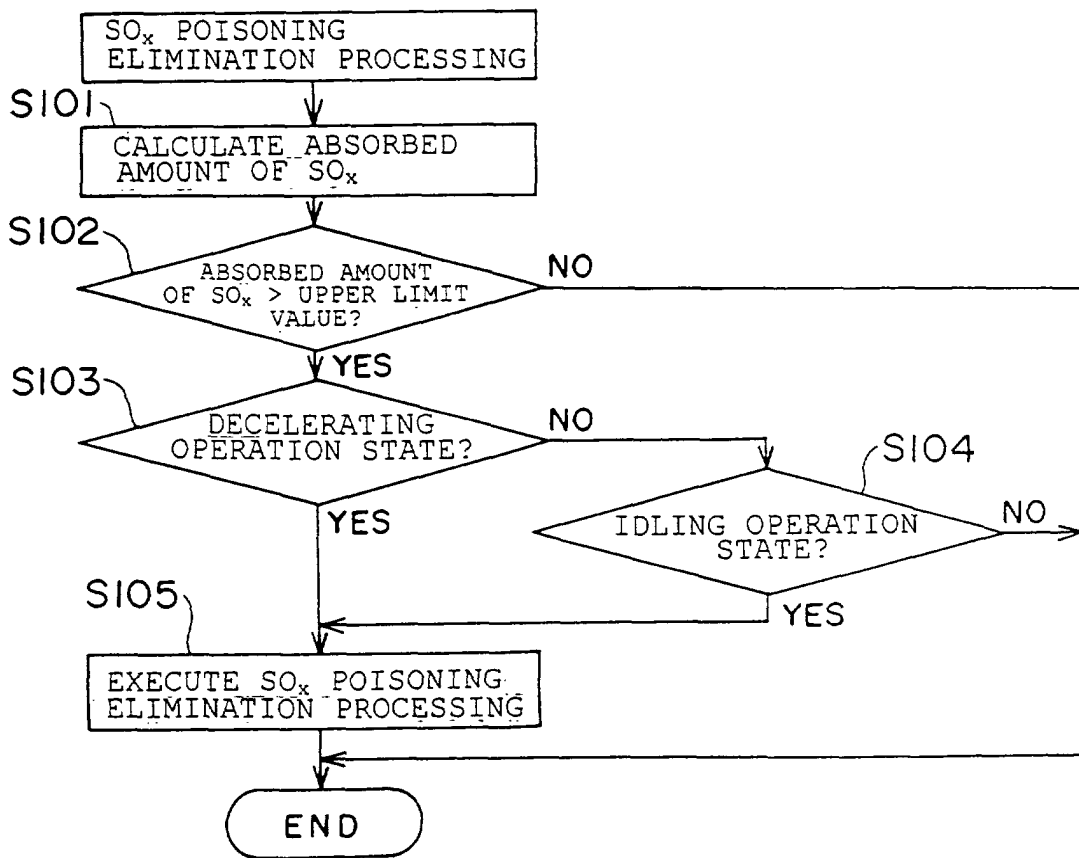
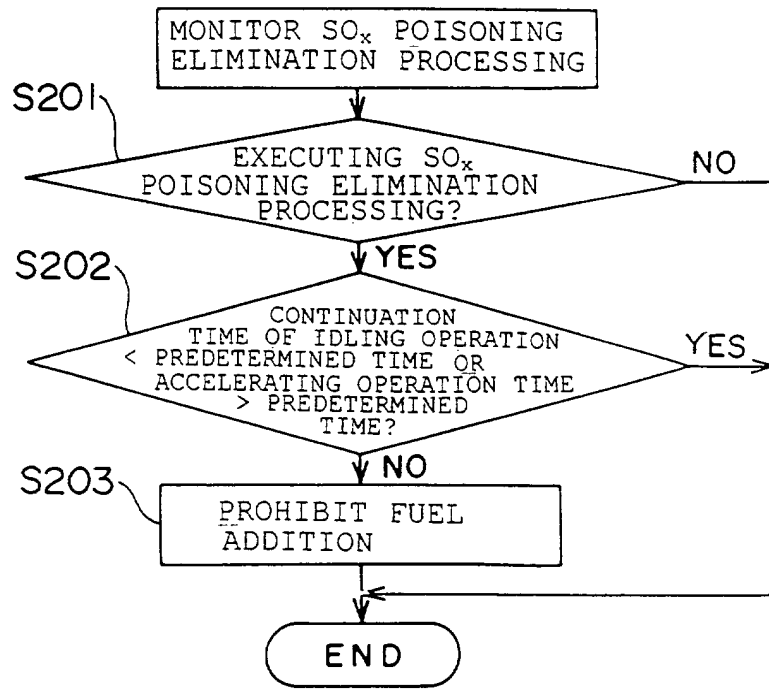

FIG. 4



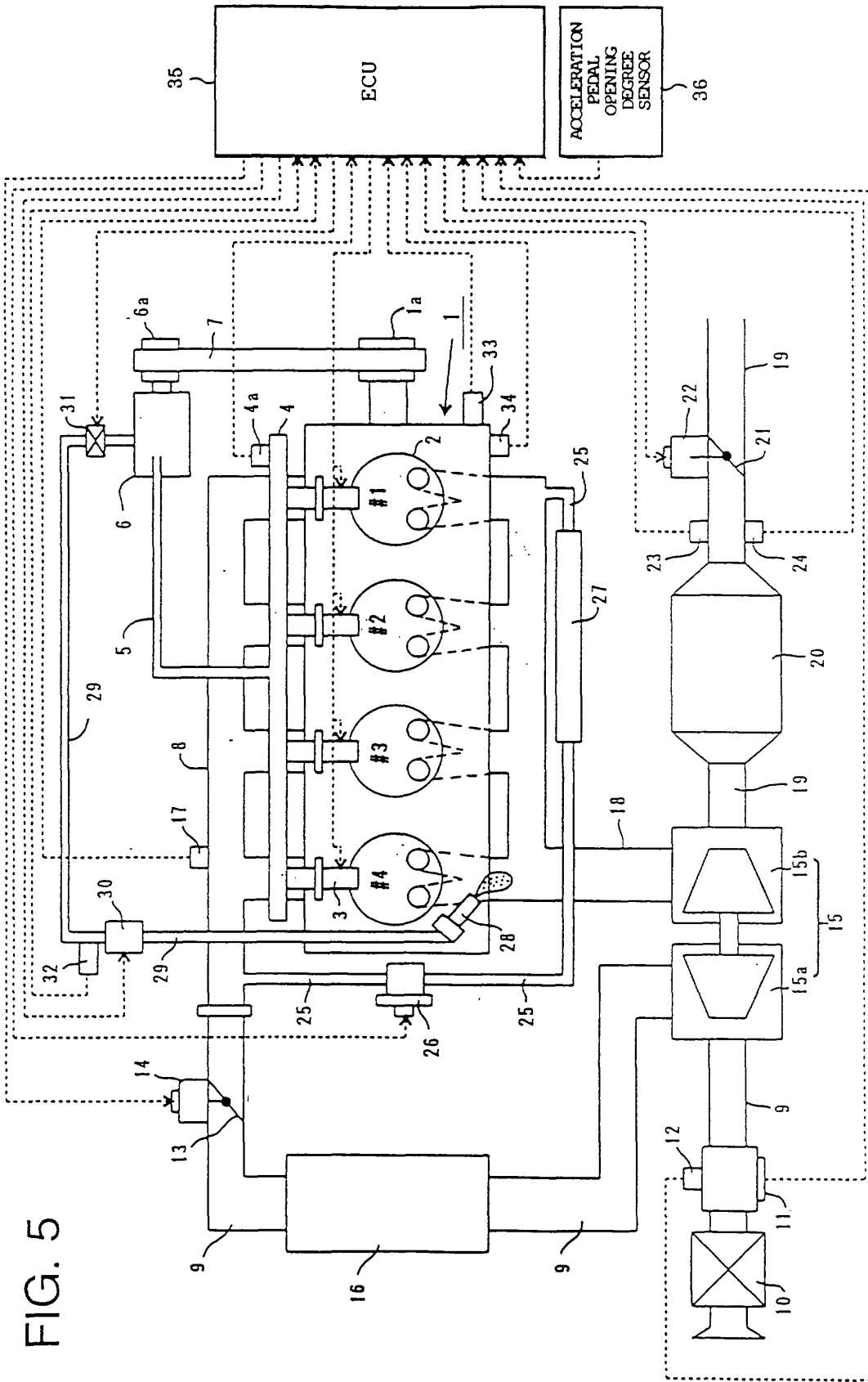

FIG. 5

FIG. 6

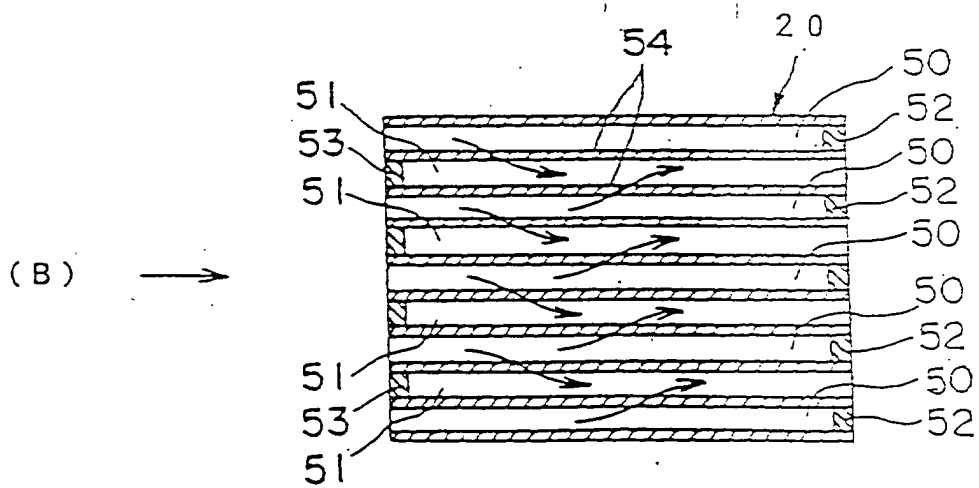
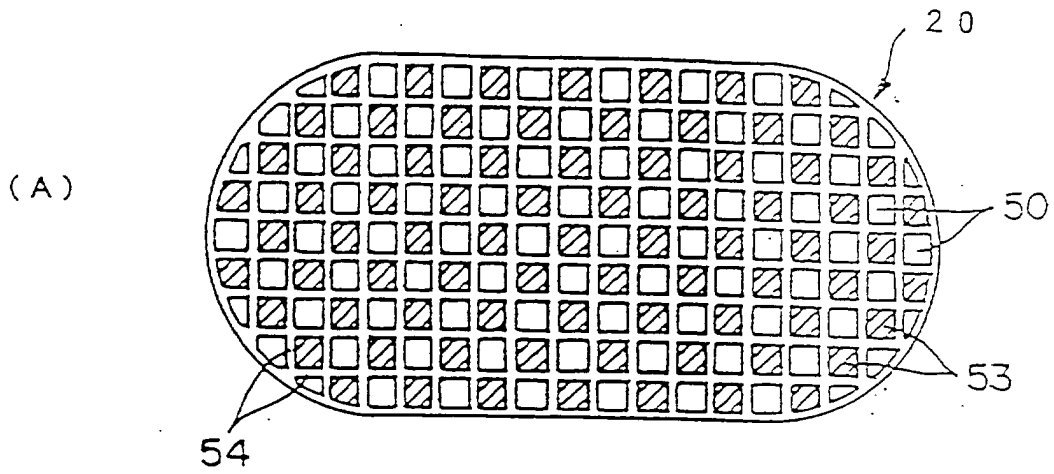

FIG. 7

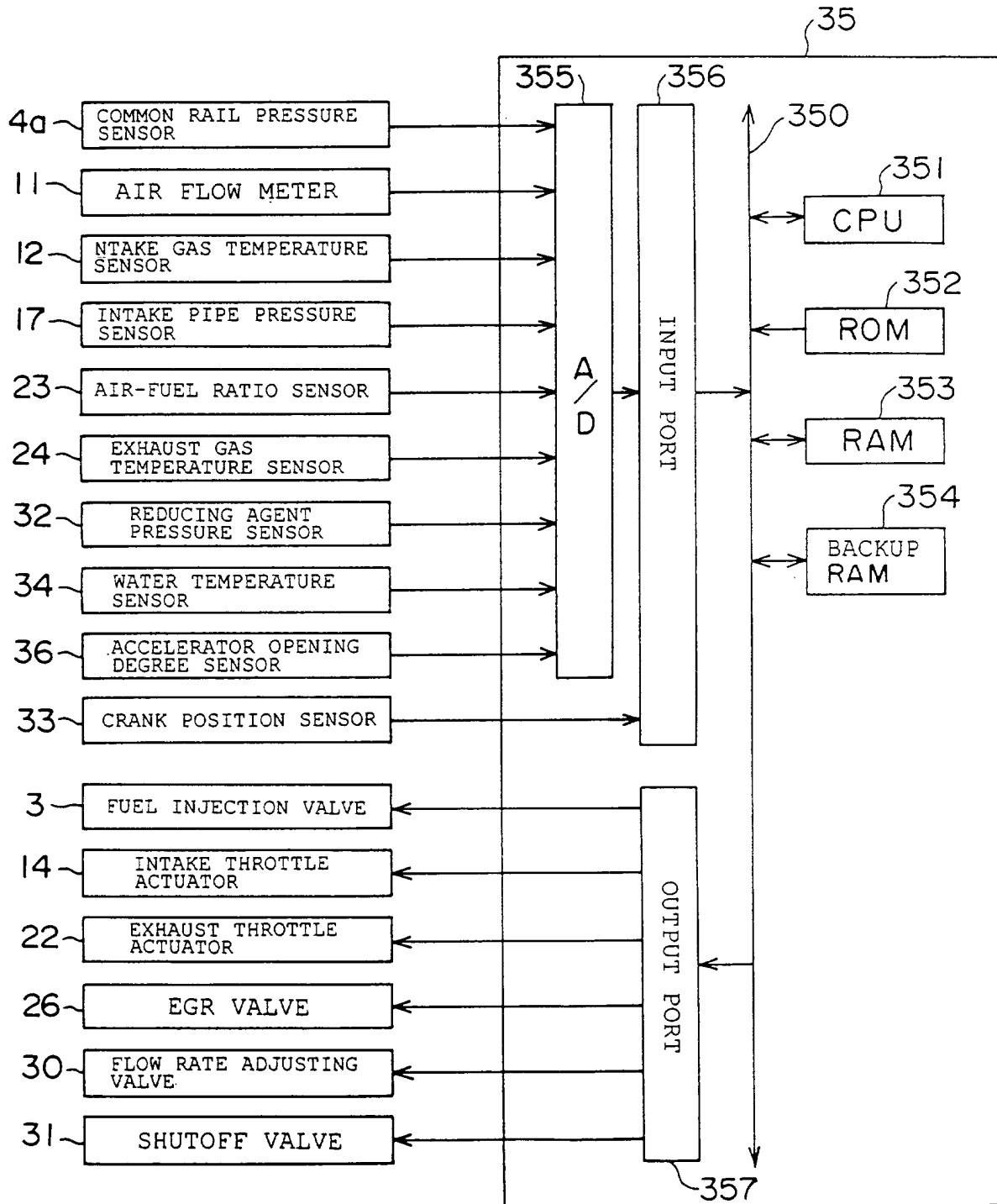

FIG. 8

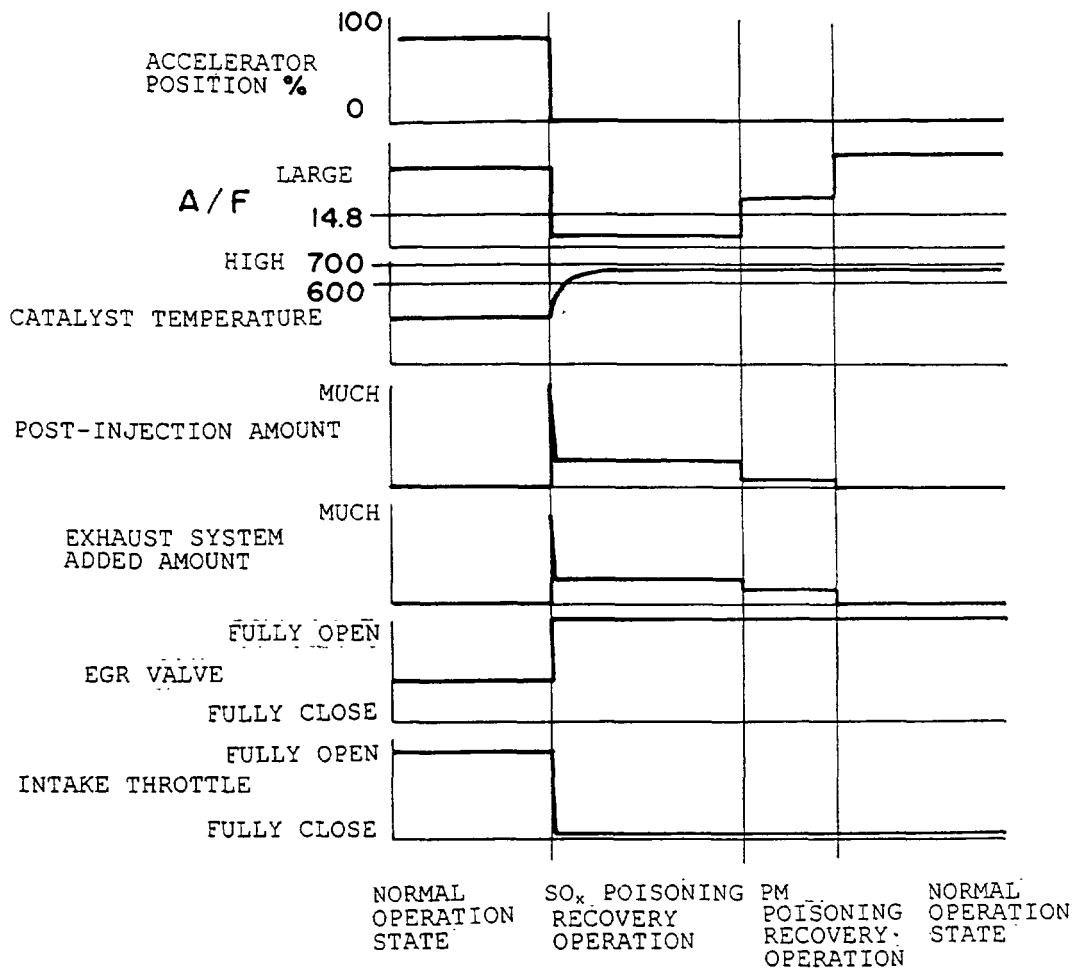

FIG. 9

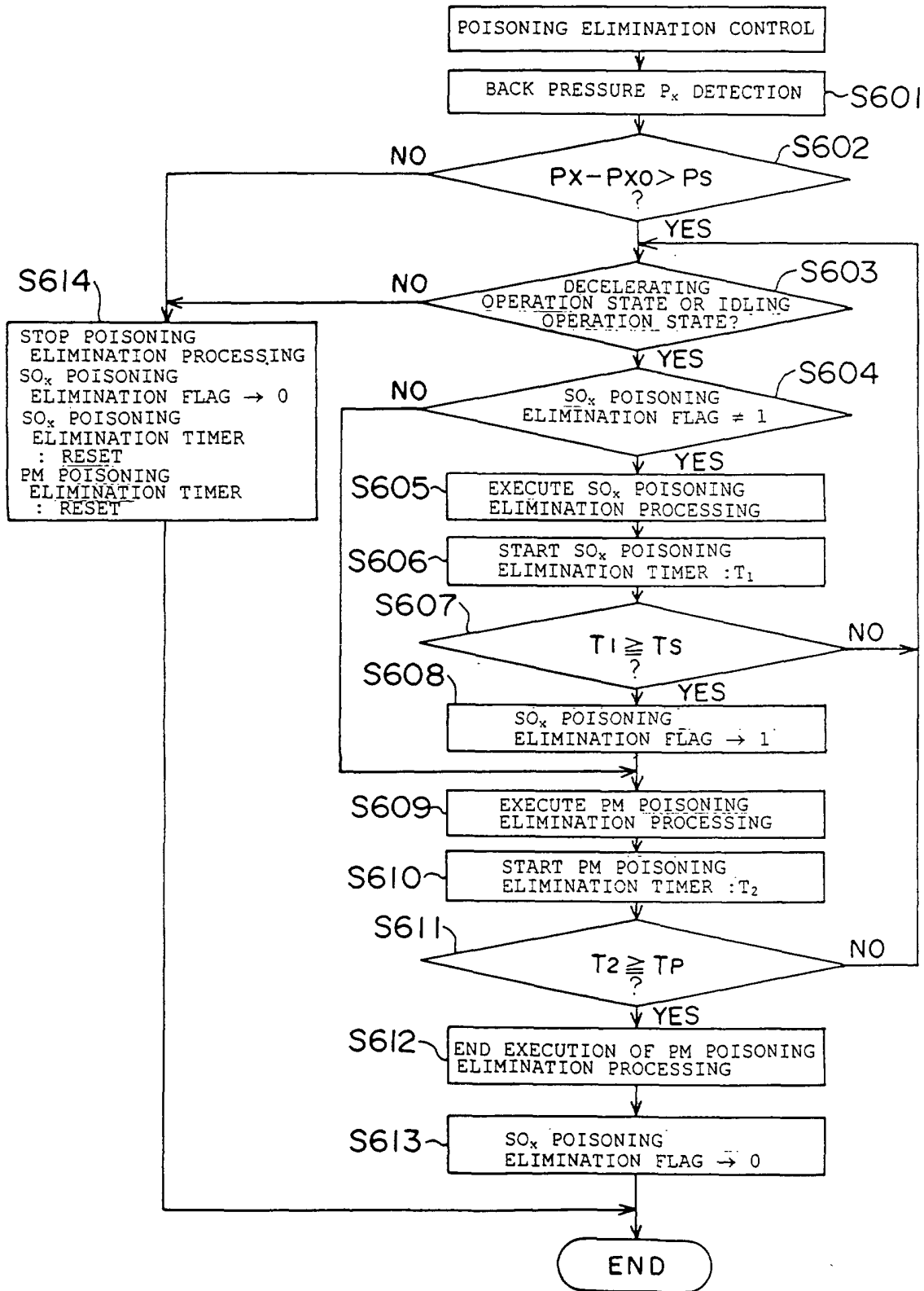

FIG. 10

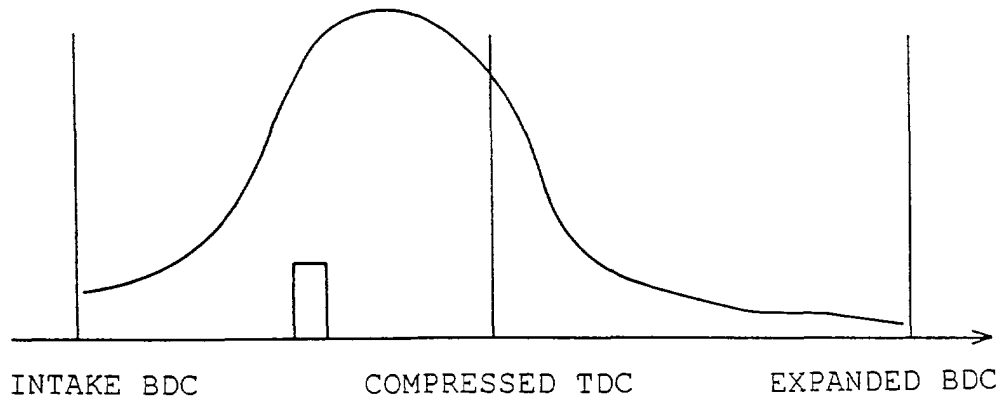
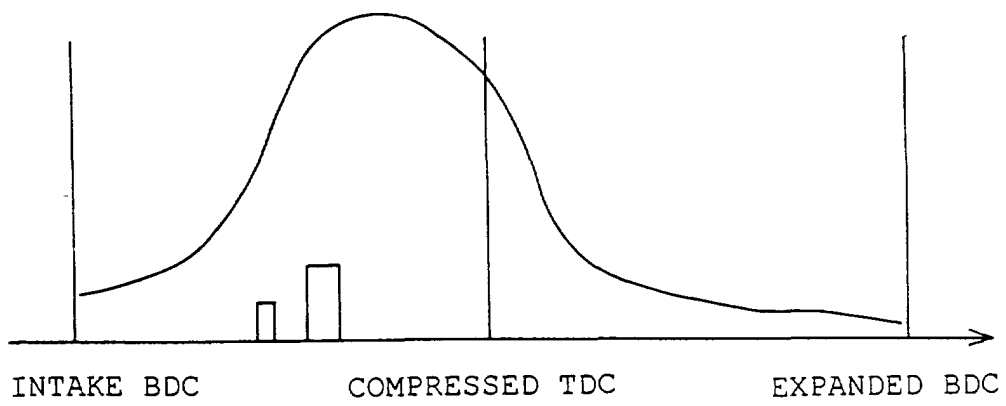

FIG. 11





European Patent Office

EUROPEAN SEARCH REPORT

Application Number
EP 01 11 7848

DOCUMENTS CONSIDERED TO BE RELEVANT			
Category	Citation of document with indication, where appropriate, of relevant passages	Relevant to claim	CLASSIFICATION OF THE APPLICATION (Int.Cl.7)
X	EP 0 598 917 A (TOYOTA MOTOR CO LTD) 1 June 1994 (1994-06-01) * column 24, line 46 - column 26, line 19 * * figure 1 *	1-5	F01N3/08 F01N3/20 F02D41/02 F02M25/07 F01N3/025 F02D21/08 F02D41/40
X	US 5 992 142 A (POTT EKKEHARD) 30 November 1999 (1999-11-30) * column 4, line 53 - column 9, line 37 * * figure 1 *	1-5	
D,A	PATENT ABSTRACTS OF JAPAN vol. 1996, no. 11, 29 November 1996 (1996-11-29) & JP 08 170558 A (NISSAN MOTOR CO LTD), 2 July 1996 (1996-07-02) * abstract *	1,4	
A	DE 198 50 757 A (VOLKSWAGENWERK AG) 17 February 2000 (2000-02-17) * column 3, line 11 - line 55 * * figure 1 *	9	
			TECHNICAL FIELDS SEARCHED (Int.Cl.7)
			F01N F02D F02M
The present search report has been drawn up for all claims			
Place of search THE HAGUE		Date of completion of the search 30 October 2001	Examiner Ingegneri, M
CATEGORY OF CITED DOCUMENTS X : particularly relevant if taken alone Y : particularly relevant if combined with another document of the same category A : technological background O : non-written disclosure P : intermediate document		T : theory or principle underlying the invention E : earlier patent document, but published on, or after the filing date D : document cited in the application L : document cited for other reasons ----- & : member of the same patent family, corresponding document	

EPC FORM 1503 03 92 (P04C01)

**ANNEX TO THE EUROPEAN SEARCH REPORT
ON EUROPEAN PATENT APPLICATION NO.**

EP 01 11 7848

This annex lists the patent family members relating to the patent documents cited in the above-mentioned European search report. The members are as contained in the European Patent Office EDP file on
The European Patent Office is in no way liable for these particulars which are merely given for the purpose of information.

30-10-2001

Patent document cited in search report	Publication date	Patent family member(s)	Publication date	
EP 0598917	A	01-06-1994	DE 69326217 D1	07-10-1999
			DE 69326217 T2	13-04-2000
			EP 0598917 A1	01-06-1994
			US 5437153 A	01-08-1995
			DE 69326417 D1	21-10-1999
			DE 69326417 T2	13-04-2000
			EP 0598916 A1	01-06-1994
			WO 9325805 A1	23-12-1993
			WO 9325806 A1	23-12-1993
			JP 2586739 B2	05-03-1997
US 5450722 A	19-09-1995			
US 5992142	A	30-11-1999	DE 19640161 A1	02-04-1998
			WO 9813128 A1	02-04-1998
			EP 0930930 A1	28-07-1999
			JP 2001502395 T	20-02-2001
JP 08170558	A	02-07-1996	NONE	
DE 19850757	A	17-02-2000	DE 19850757 A1	17-02-2000
			WO 0008311 A1	17-02-2000
			EP 1102920 A1	30-05-2001

EPC FORM P/459

For more details about this annex : see Official Journal of the European Patent Office, No. 12/82