



(12) **EUROPEAN PATENT APPLICATION**

(88) Date of publication A3:  
**14.05.2003 Bulletin 2003/20**

(51) Int Cl.7: **C14B 5/00, C14B 17/04,  
C14B 17/06**

(43) Date of publication A2:  
**06.02.2002 Bulletin 2002/06**

(21) Application number: **01114830.1**

(22) Date of filing: **28.06.2001**

(84) Designated Contracting States:  
**AT BE CH CY DE DK ES FI FR GB GR IE IT LI LU  
MC NL PT SE TR**  
Designated Extension States:  
**AL LT LV MK RO SI**

(72) Inventor: **Gallucci, Gianni**  
**63015 Monte Urano (Ascoli Piceno) (IT)**

(74) Representative: **Dall'Olio, Giancarlo**  
**c/o INVENTION s.a.s.,**  
**Via delle Armi, 1**  
**40137 Bologna (IT)**

(30) Priority: **04.07.2000 IT BO000393**

(71) Applicant: **Teseo S.p.A.**  
**63023 Fermo (Ascoli Piceno) (IT)**

(54) **Apparatus for removable fastening of flat articles, like leathers and similar to a work surface**

(57) In an apparatus for removable fastening of flat articles (2) to a work surface (1) for a machine for processing flat articles, e.g. leathers, the work surface (1) includes a plurality of fastening elements (3), which are selectively connected to suction means by respective valve means (10) to set under a vacuum effect the articles (2). Each of the valve means (10) includes a throttle valve (12), operated by a direct-current motor

(21). The apparatus includes also sensor means (23) for detecting the motor (21) supply voltage and detecting variations with respect to the nominal voltage due to the motor rotation. Furthermore, the apparatus includes a sensor (24) detecting the current flowing through the motor (21) for detecting a motor (21) stop situation which is a consequence of reaching one of the extreme positions full open (A) and full closed (B) by the throttle valve (12).

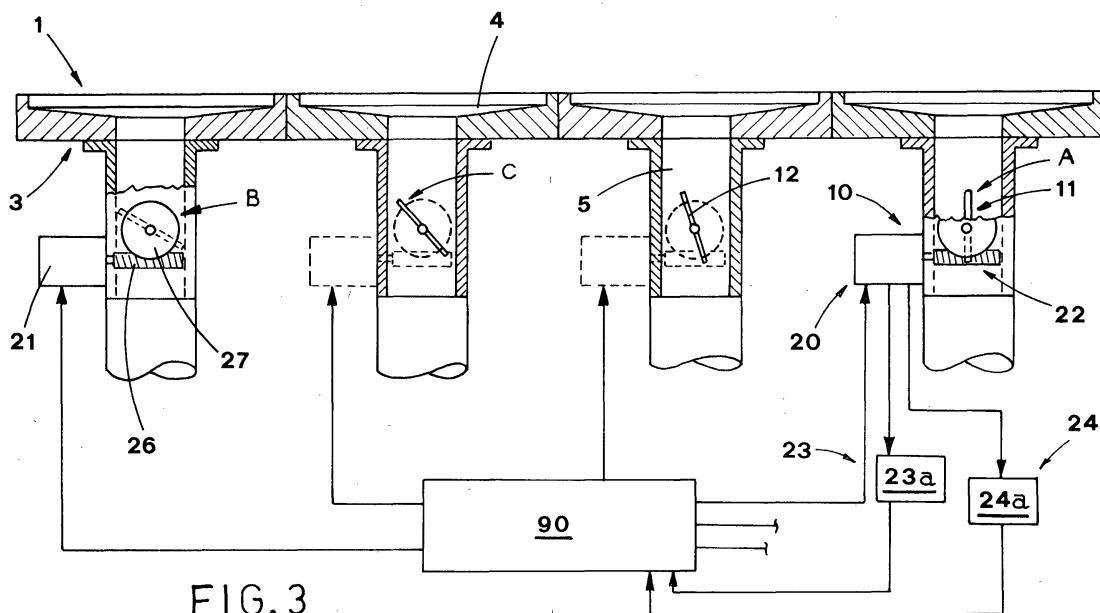



European Patent  
Office

EUROPEAN SEARCH REPORT

Application Number  
EP 01 11 4830

DOCUMENTS CONSIDERED TO BE RELEVANT			
Category	Citation of document with indication, where appropriate, of relevant passages	Relevant to claim	CLASSIFICATION OF THE APPLICATION (Int.CI.7)
A	DE 195 21 616 C (FELBER) 17 July 1997 (1997-07-17) * the whole document * ---	1,6	C14B5/00 C14B17/04 C14B17/06
A	US 5 953 232 A (BLAIMSCHEIN) 14 September 1999 (1999-09-14) * the whole document * ---	1,6	
A	EP 0 566 817 A (GFM) 27 October 1993 (1993-10-27) * the whole document * -----	1,6	
			TECHNICAL FIELDS SEARCHED (Int.CI.7)
			C14B
The present search report has been drawn up for all claims			
Place of search <b>THE HAGUE</b>		Date of completion of the search <b>27 March 2003</b>	Examiner <b>De Rijck, F</b>
CATEGORY OF CITED DOCUMENTS		T : theory or principle underlying the invention E : earlier patent document, but published on, or after the filing date D : document cited in the application L : document cited for other reasons ..... & : member of the same patent family, corresponding document	
X : particularly relevant if taken alone Y : particularly relevant if combined with another document of the same category A : technological background O : non-written disclosure P : intermediate document			

EPO FORM 1508 03/82 (P04C01)

**ANNEX TO THE EUROPEAN SEARCH REPORT  
ON EUROPEAN PATENT APPLICATION NO.**

EP 01 11 4830

This annex lists the patent family members relating to the patent documents cited in the above-mentioned European search report. The members are as contained in the European Patent Office EDP file on The European Patent Office is in no way liable for these particulars which are merely given for the purpose of information.

27-03-2003

Patent document cited in search report		Publication date	Patent family member(s)	Publication date
DE 19521616	C	17-07-1997	DE 19521616 C1	17-07-1997
US 5953232	A	14-09-1999	AT 405497 B	25-08-1999
			AT 59096 A	15-01-1999
			AT 220115 T	15-07-2002
			DE 59707621 D1	08-08-2002
			EP 0799898 A2	08-10-1997
EP 566817	A	27-10-1993	EP 0566817 A1	27-10-1993