



(12) **EUROPEAN PATENT APPLICATION**

(43) Date of publication:  
**06.03.2002 Bulletin 2002/10**

(51) Int Cl.7: **A61G 7/018**

(21) Application number: **00610088.7**

(22) Date of filing: **01.09.2000**

(84) Designated Contracting States:  
**AT BE CH CY DE DK ES FI FR GB GR IE IT LI LU  
MC NL PT SE**  
Designated Extension States:  
**AL LT LV MK RO SI**

(72) Inventor: **Dyhr, Klaus B.  
Tingerup, 4330 Hvalsoe (DK)**

(74) Representative: **Nielsen, Henrik Sten et al  
Budde, Schou & Ostenfeld A/S Vester Søgade 10  
1601 Copenhagen V (DK)**

(71) Applicant: **Invacare EC-Hoeng  
4270 Hoeng (DK)**

(54) **A bed and a remote control terminal for use in connection with a bed**

(57) A bed (60) comprises a bed frame divided into a plurality of sections constituting individual sections (64, 66, 68, 70) for supporting the back or the head of a person lying on or sitting in the bed, for supporting the person's buttocks, for supporting the person's thigh, and for supporting the person's crus and feet. The bed further comprises connector means linking the bed frame sections (64, 66, 68, 70) together in a continuous bed frame structure and allowing the individual bed frame section to pivot relative to the adjacent bed frame section and a further plurality of actuator means (A, B, C, D) for raising or lowering the respective bed frame section relative to the adjacent bed frame section through pivoting the respective bed frame section relative to the adjacent bed frame section. The bed also includes control means communicating with and controlling the actuator means through the supplying of addressing orders to the actuator means (A, B, C, D), and a remote control terminal (10) communicating with the control means and including a set of manually operable switch means (26, 28, 30, 32), each individual switch means representing a specific position of each of the bed frame sections (64, 66, 68, 70) of the plurality of bed frame sections an each switch means of the set of switch means transmitting a specific order to the control means when the switch means in question is manually actuated and the control means transforming the specific order into a set of addressing orders supplied to the actuator means (A, B, C, D) of the further plurality of actuators means for establishing a shift of the position of the individual bed frame sections into the position represented by the switch means in question (Figs. 1 and 3).

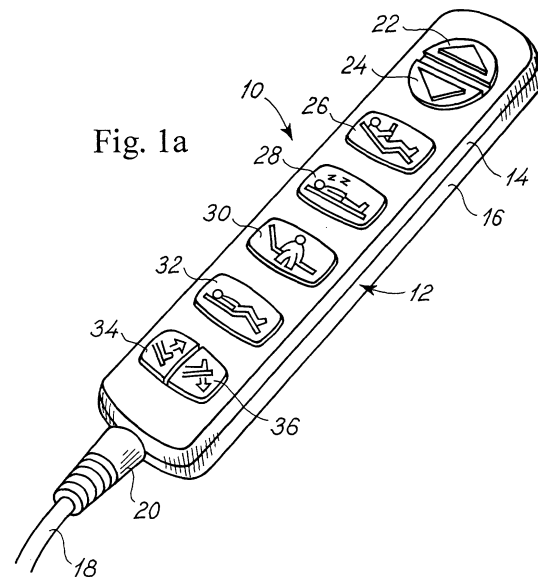

Fig. 1a

Fig. 1b

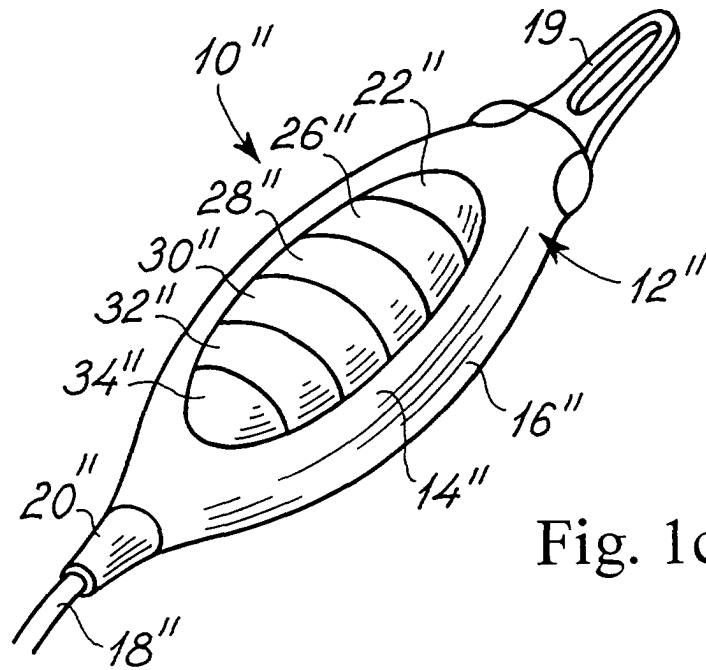
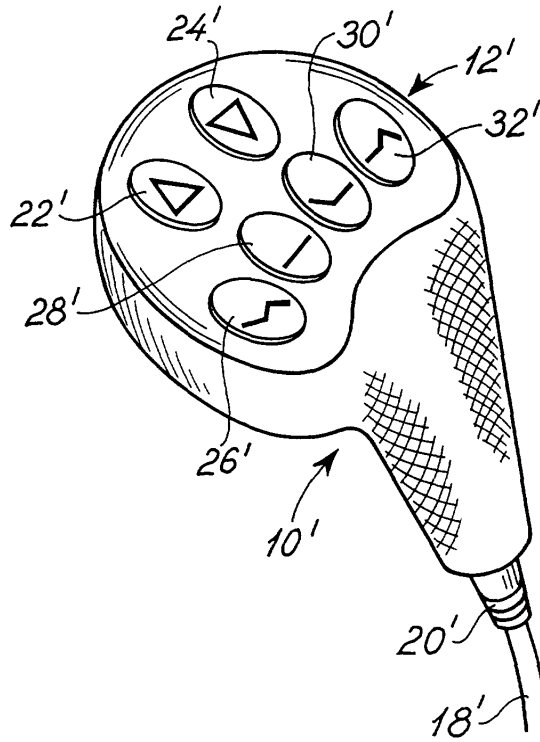

Fig. 1c

## Description

**[0001]** The present invention relates generally to the technical field of beds and in particular to hospital beds or beds used for nursing applications or similar applications and of the kind having a bed frame divided into a plurality of mutually displaceable sections. The present invention also relates to a piece of furniture of the kind occasionally called a sitting or lying furniture. In the present context the word bed is, however, used throughout the specification as a generic term representing furniture of the kind generally named beds and similar furniture such as sitting or lying furniture or any other appliance of furniture used for the same purpose as a conventional bed.

**[0002]** The bed is, as is well known, adapted to support a person in a lying or sitting posture. The person may e.g. be a patient who is hospitalised or may e.g. be a person at a rest home of residential home. The person being a patient or a person of the above kind may be supported directly by the sections of the bed frame or supported by a mattress which is further supported by the sections of the bed frame. The sections of the bed frame may have identical size or be sized differently for complying with differences in the relevant body parts to be supported by the various sections. Further the sections may be of identical structure or may be of different structure as some or all of the sections of the bed frame may be constituted by mesh structures, grid or lamella structures, structures composed of segments of slats or tubes which may further be solid or at least partly flexible or bendable. The structure of the bed frame and the individual sections of the bed frame may per se be of a structure well known within the art and the sections of the bed frame may further or alternatively be ergonomically shaped for provided an improved supporting effect.

**[0003]** The prior art beds comprising bed frame sections have been implemented as structures engineered by technicians having focussed on the ability of the bed to obtain the highest degree of flexibility and allowing the person or patient sitting or lying the bed to be positioned in as many positions as possible for simply allowing the bed through adjusting the bed frame structure to the person or patient sitting or lying in the bed to accommodate any arbitrary position of the bed frame structure involving the positioning of the number of bed frame sections in any arbitrary position relatively to the remaining bed frame sections of the bed. In general, bed frame sections being powered by actuators independently or through linking structures are able to move up or down as the remote control terminals for adjusting the bed frame sections in relation to one another and in relation to the supporting floor have been developed by technicians focusing on the ability of obtaining the highest degree of freedom as to positioning of the bed frame sections. Consequently, the remote control terminals have been implemented having separate push bottoms or

similar elements allowing the person operating the remote control terminal to move each section of the bed frame structure up or down independent on the position or the movement in general of the remaining bed frame sections. However, considerations have been made as to eliminating the risk of positioning the bed frame sections in positions which might cause harm or injury to the person sitting or lying in the bed and the central computer included in the controller of the bed and addressed by the control terminal has consequently included a limiting programme preventing the bed frame sections from being positioned in extreme positions which might cause injuries to the person or patient lying or sitting in the bed and also cause damage to the whole bed frame structure and the bed structure itself.

**[0004]** The prior art beds including a bed frame divided into a plurality of subsections which are independently movable up and down have proven to be not entirely satisfactory from the point of view of the person operating the remote control terminal and from the point of view of the patient or person sitting or lying in the bed. The reason for this not entirely perfect fulfilment of the requirements as to the utilisation of the bed is believed to be originating from a kind of fear as the infinite number of possible positions of each of the sections of the bed frame structure may scare the cautious person operating the remote control terminal of the bed as the person may be somewhat afraid of moving the individual bed frame sections, exclusively, which might cause harm to the person such as an elderly patient lying or sitting in the bed. Furthermore, it is believed that a further reason for this not entirely perfect fulfilment of the requirements adds to utilization of the bed is believed to originate from a lack of skill as the person operating the remote control terminal may often lack the technical skill and the technical understanding of how to operate the remote control terminal for positioning the bed frame in a specific position as requested by the patient or person sitting or lying in the bed or needed for a particular nursing or handling operation.

**[0005]** As the person operating the remote control terminal is afraid of moving the bed frame sections to far up or down, the prior art bed structures having independent operable bed frame sections which may be positioned in an infinite number of mutual positions have not been used as originally intended by the technicians constructing and implementing the beds and the nursing staff have therefore in some instances expressed a need for a more easily and more safely operable bed than the prior art bed frame structures which may be positioned in an infinite number of positions.

**[0006]** An object of the present invention is to provide a bed of the above kind, i.e. a bed having a bed frame divided into a plurality of individual sections which bed may be easily and safely operated by the staff nursing a person or patient lying or sitting in the bed and which bed allows the person operating the remote control terminal to position the bed frame structure in adequate

positions relevant in the nursing and handling of persons or patients.

**[0007]** It is an advantage of the present invention that the bed implemented in accordance with the teachings of the present invention may be readily used for obtaining specific and advantageous utilitarian positions.

**[0008]** It is a particular feature of the present invention that the bed may be operated by the staff nursing a patient or person lying or sitting in the bed or by the patient or person himself or herself in an easily understandable and self-explanatory manner.

**[0009]** The above object, the above advantage and the above feature together with numerous other objects, advantages and features of the present invention which will be evident from the below description of presently preferred embodiments of the present invention is obtained by a bed comprising a bed frame divided into a plurality of sections constituting individual sections for supporting the back or the head of a person lying on or sitting in the bed, for supporting the person's buttocks, for supporting the person's thigh, and for supporting the person's crur and feet, connector means linking the bed frame sections together in a continuous bed frame structure and allowing the individual bed frame section to pivot relative to the adjacent bed frame section, a further plurality of actuator means for raising or lowering the respective bed frame section relative to the adjacent bed frame section through pivoting the respective bed frame section relative to the adjacent bed frame section, control means communicating with and controlling the actuator means through the supplying of addressing orders to the actuator means, and a remote control terminal communicating with the control means and including a set of manually operable switch means, each individual switch means representing a specific position of each of the bed frame sections of the plurality of bed frame sections and each switch means of the set of switch means transmitting a specific order to the control means when the switch means in question is manually actuated and the control means transforming the specific order into a set of addressing orders supplied to the actuator means of the further plurality of actuators means for establishing a shift of the position of the individual bed frame sections into the position represented by the switch means in question.

**[0010]** According to the teachings of the present invention the individual sections of the bed frame are not moved independently of one another by means of the remote control terminal and may not be positioned in any arbitrary position relative to the remaining bed frame sections or the supporting floor. According to the teachings of the present invention, the bed frame is allowed to be positioned in specific positions exclusively, such as a lying, a sitting, a moving or getting out of the bed position and further e.g. a rest position or any other relevant nursing or hospitalisation position, exclusively. The repositioning of the bed is accomplished by simply depressing a single key for bringing about a shift of the

plurality of bed frame sections from one previously position corresponding to one of the above mentioned specific positions such as a sitting position to another specific position such as e.g. a lying or resting position.

**[0011]** It is contemplated that the concept of positioning the bed frame sections in specific positions rather than allowing the individual bed frame sections to be positioned in any number of positions or in an infinite number of positions independent of the positions of the other bed frame sections gives the person operating the bed by means of the remote control terminal a feeling of safety and security and also gives the person or patient sitting or lying in the bed a feeling of comfort and safety as the bed may be positioned in a set of specific positions exclusively and cannot be operated in a manner which might cause harm or injuries to the person or patient sitting or lying in the bed.

**[0012]** A number of remote control terminals to be used in connection with beds are known from e.g.: US 5,544,376, GB 1086827, US 3,697,986, EP 0 341 358 and US 6,008,598, to which patent applications and patents reference is made and which US patents are hereby incorporated in the present specification by reference.

**[0013]** It is to be realised that certain prior art beds have been constructed having a specific Trendelenburg position in which the individual bed frame sections are positioned having the foot end raised in relation to the head end. It is, however, to be understood that the prior art beds and the prior art remote control terminals to be used in connections with beds and having a single pre-set position, namely the Trendelenburg position, have been developed in accordance with the above described technical considerations according to which the individual bed frame sections may be moved up and down independently on the other bed frame sections except for the one Trendelenburg position whereas the bed according to the present invention is based on the basic realisation of allowing the person operating the remote control terminal to position the bed frame sections of the bed in a limited number of specific positions, exclusively, rather than allowing the person operating the remote control terminal to raise or lower the individual bed frame sections independently of the other bed frame sections.

**[0014]** As mentioned above, the bed includes a first plurality of sections together defining the bed frame and a further plurality or second plurality of actuators. Dependent on the structure of the bed and in particular the structure of the bed frame, the number of actuators may be identical to or different from the number of bed frame sections. Consequently, according to a first embodiment of the bed according to the present invention, the number of actuators is identical to the number of bed frame sections as each and every bed frame section is powered by a single actuator. According to an alternative embodiment of the bed according to the present invention, one or more bed frame sections are powered

by more than one actuator and the number of actuators is consequently larger than the number of bed frame sections. Alternatively or supplementary, according to a further or alternative embodiment of the bed according to the present invention, one or more bed frame sections may be fixed or mechanically linked to another bed frame section and consequently unpowered by actuators in which case the number of actuators may be smaller than the number of bed frame sections unless one or more of the bed frame sections is powered by more than one actuator.

**[0015]** It is to be realised that the control means of the bed according to the present invention preferably includes a central computer means such as a microprocessor means or microprocessor based controller communicating with and controlling the actuator means and further receiving the orders from the remote control terminal. The provision of a central computer means such as a microprocessor based controller within the control means of the bed brings about a number of advantages as to controlling the operation of the bed and further of programming the control means in accordance with specific requirements determined by the patient or person sitting or lying in the bed or determined by the general application of the bed for specific purposes. Consequently, provided a microprocessor based controller be used, the positions of the bed frame section corresponding to the individual switch means of the set of switch means included in the remote control terminal may be pre-set or programmed according to specific requirements rather than be determined by the geometrical structure of the bed. Furthermore, the provision of the central computer means such as a microprocessor controller within the control means of the bed according to the present invention provides additional advantages as to communication and controlling as is well known within the computer art per se.

**[0016]** According to the above realisation of providing a maximum of safety and security to the patient or person lying or sitting in the bed and also a feeling of safety to the person operating the remote control terminal, the central computer of the control means of the bed may advantageously include a limit programme monitoring the motion of the individual bed frame sections by means of separate detectors or through monitoring the motion of the individual actuators for adjusting the motion of the individual actuators dependent on the motion of the other actuators for preventing the actuators from raising or lowering the bed frame sections or a single bed frame section beyond specific allowable limits such as a specific maximum inclination relative to an adjacent bed frame section. The limit program of the central computer of the bed may further as is well known in the art include specific outer boundary limits preventing, in case of malfunction, the actuators from moving beyond the allowable limits and preventing in the first place the person or patient lying in the bed from being injured or harmed and in the second place preventing the actua-

tors from damaging the bed frame structure or the bed itself.

**[0017]** The remote control terminal of the bed according to the present invention may be implemented in any appropriate manner as an independent remote terminal as an integral control terminal of the bed and may further communicate with the control means of the bed in any appropriate matter such as through a wireless link or a wired link. Provided a cable connection is established between the remote control terminal and the control means, the cable connection may be implemented as a multicore cable connection in which each specific order generated by the switch means of the remote control terminal is transmitted through a respective wire connection or alternatively, the remote control terminal may include multiplexing means such as time divisional multiplexing means or frequency multiplexing means allowing a two wire cable or a coax cable to be used for transmitting the specific orders generated by the switch means of the remote control terminal through a single two wire or coax cable link. According to a different implementation of the remote control terminal of the bed according to the present invention, the connection between the remote control terminal and the control means of the bed is established as an optical link or alternatively as a wireless link being an optical, an ultrasonic, an radio-transmission or infrared link. Further alternatively, the remote control terminal may be constituted by a PC (personal computer) communicating with a central computer means of the control means of the bed through a parallel or serial link such as a local or public network.

**[0018]** Provided the communication between the remote control terminal and the control means of the beds of the type involving signal transformation such as conversion of DC signals into frequency multiplexed or time divisional multiplex signals, the transmission link may also include an information link from the control means to the remote control terminal in which instance the remote control terminal preferably also includes a display for informing the person holding and operating the remote control terminal about the status of the bed and also the operation of the bed.

**[0019]** According to techniques well known within this technical field per se, the bed preferably comprises an additional, exterior frame in which the bed frame divided into a plurality of individual sections is journalled. The exterior frame may further as is well known in the art comprise a head and a foot board and the exterior frame may be journalled or supported on an underframe which preferably is a frame positioned on wheels allowing the bed to be moved easily from one place to another.

**[0020]** The exterior frame may, according to alternative embodiments of the bed according to the present invention, constitute a stationary exterior frame or may, alternatively and preferably, be raisable or lowerable relative to the underframe by means of a separate actuator allowing the person controlling the operation of the bed to raise or lower the exterior frame such as for making

it more easy for the person sitting or lying the bed to get out of the bed by lowering the exterior frame to a low position or alternatively to raise the exterior frame to a high or elevated position for certain nursing purposes.

**[0021]** The remote control terminal including the manually operable switch means characteristic of the present invention allowing the bed frame sections to be positioned in specific pre-set positions rather than allowing each and every bed frame section to be raised or lowered independently of the other bed frame sections, may further for certain applications include one or more switch means for ordering a specific actuator to raise or lower a specific bed frame section. It is contemplated that for some purposes, a person sitting or lying in a bed may wish to have the section supporting the back and head of the person raised or lowered relative to the sitting position for obtaining a higher degree of comfort. Similar specific applications may require the independent adjustment of the individual bed frame sections from the individual positions characteristic of the present invention.

**[0022]** The actuators of the bed according to the present invention may be constituted by any appropriate power generating element such as hydraulic, pneumatic or electric power driven elements or alternatively pressurised air operated elements. Preferably, the actuators are constituted by electric power driven elements such as electric motors or electric actuators and further preferably, the actuator means are constituted by low voltage electric motors including linear or displaceable rods or arms as the low voltage electric motors allows the bed to be constructed including low voltage elements exclusively for eliminating the risk of exposing the person sitting or lying in the bed to excessive electric shocks from e.g. a mains supply outlet.

**[0023]** The present invention further relates to a remote control terminal for use in connection with a bed for obtaining the above object, advantage and feature together with numerous objects, advantages and features which will be evident from the below description of presently preferred embodiments of the present invention, which bed comprises bed frame divided into a plurality of sections constituting individual sections for supporting the back or the head of a person lying on or sitting in the bed, for supporting the person's buttocks, for supporting the person's thigh, and for supporting the person's crus and feet, connector means linking the bed frame sections together in a continuous bed frame structure and allowing the individual bed frame section to pivot relative to the adjacent bed frame section, a further plurality of actuator means for raising or lowering the respective bed frame section relative to the adjacent bed frame section through pivoting the respective bed frame section relative to the adjacent bed frame section, and control means communicating with and controlling the actuator means through the supplying of addressing orders to the actuator means, the remote control terminal having a communication link being a wire connection

or a wireless link for communicating with the control means of the bed and including a set of manually operable switch means, each individual switch means representing a specific position of each of the bed frame sections of the plurality of bed frame sections and each switch means of the set of switch means transmitting a specific order through the communication link to the control means when the switch means in question is manually actuated for causing the control means to transform the specific order into a set of addressing orders supplied to the actuator means of the further plurality of actuators means for establishing a shift of the position of the individual bed frame sections into the position represented by the switch means in question.

**[0024]** The present invention is now to be further described with reference to the drawings in which

figs. 1a, 1b and 1c are perspective and schematic views of three alternative embodiments of a remote control terminal to be used in connection with a bed, in particular a hospital bed,

fig. 2 is a schematic view of a simple wiring scheme of controlling four bed frame motors of a bed by means of the remote control terminal illustrated in fig. 1a,

fig. 3 is an elevational, schematic and partly broken away view of a four section bed including four actuators and controllable in accordance with the teachings of the present invention by means of the remote control terminal such as the remote control terminal illustrated in figs. 1a and fig. 2, and

fig. 4 is a schematic view illustrating a wireless remote control terminal to be used in connection with the bed illustrated in fig. 3.

**[0025]** In fig. 1a, a first and presently preferred embodiment of a remote control terminal implemented in accordance with the teachings of the present invention and to be used in connection with a control system of a bed also implemented in accordance with the teachings of the present invention is shown. The control terminal illustrated in fig. 1a is in its entirety designated the reference numeral 10 and includes a housing 12 composed of a top housing part 14 and a bottom housing part 16. The two housing parts 14 and 16 together constituting the housing 12 may be fit together by means of screws or simply snap fitted together establishing the housing 12. From the lower end of the housing 12, a multicore cable 18 extends through a bushing 20.

**[0026]** Within the housing 12, a plurality of switches is positioned preferably mounted on a printed circuit board. The switches may be operated by means of keys exposed at the top surface of the top housing part 14. At the top of the housing 12 opposite the bushing 20, two keys 22 and 24 are provided which keys serve the

purpose of allowing a person holding the control terminal 10 to raise an exterior frame of a bed by operating the key 22 or alternatively lowering the outer frame of the bed by operating or depressing the key 24. A further set of keys 26, 28, 30 and 32 are provided constituting keys characteristic of the present invention. The key 26 like the keys 28, 30 and 32 serve the purpose of allowing the person holding and operating the control terminal 10 to position the individual sections of the bed in a specific position by the simple operation of a single key rather than operating the individual motors of the sectional bed one at the time.

**[0027]** By operating the key 26, the control system of the bed connected to the control terminal 10 causes the motors such as the four motors of a bed to be described below to position the four sections of the bed in positions resembling the diagram of the key 26 or more precisely in a position allowing the person lying in the bed to have his or her back rest raised and the foot rest lowered for allowing the person to read in a newspaper or in a book as illustrated schematically in the diagram on the key 26.

**[0028]** Similarly by the operation of the key 28, the sections of the bed are all positioned in a horizontal orientation allowing the individual resting or lying on the bed to sleep as illustrated diagrammatically on the key 28. The single bottom operation concept of the present invention further allows the person holding an operating the control terminal 10 to position the bed in a position illustrated on the key 30 in which position the back rest of the bed is raised which position makes it more easy for a person lying or resting in the bed to raise to a standing position or be raised to a standing position as is illustrated on the key 30 which illustrates the person sitting on the edge of the bed having his or her legs depending from the bed rest. The key 32 further allows the person holding an operating the control terminal 10 to position the sections of the bed in a specific resting position in which the section supporting the person's thighs is raised whereas the section supporting the person's crus and feet are lowered. It is to be realised that the keys 26, 28, 30 and 32 in accordance with the teachings of the present invention cause through operation the individual sections of the bed frame of the bed to be positioned in specific positions as illustrated schematically on the respective keys as distinct from the prior art control terminals which include a set of keys allowing the person holding and operating the control terminal to operate a single motor of the bed frame system one at the time for raising or lowering a specific section of the bed frame system independent on the position and the motion of the other sections of the bed frame system.

**[0029]** The control terminal 10 further includes two keys positioned at the lower end of the top housing part 14 which keys resemble the prior art operation keys of prior art remote control terminals as the keys 34 and 36 allows the person holding and operating the control terminal 10 to lower or alternatively raise the section of the bed frame system supporting the crus and feet of the

person resting or lying in the bed. It has been realised that the position of the section supporting the crus and feet of the person or individual lying or resting in the bed is to some extent individually determined and a incorrect position of the section supporting the crus and feet of the person lying or resting on the bed may give origin to a feeling of discomfort to the person or individual. The keys 34 and 36 may alternatively be used for establishing the above described Trendelenburg position by raising or lowering the section of the bed frame system supporting the crus and feet of the person lying or resting in the bed. Alternatively, provided the bed is of a structure having a head end and foot end including separate actuators for raising or lowering the frame supported by the head end and foot end, the keys 34 and 36 may be used for addressing and operating the actuators included in the head end and foot end, respectively and in doing so, establishing a position of tilt of the bed frame relative to the supporting surface.

**[0030]** In figs. 1b and 1c, two alternative embodiments of the control terminal implemented in accordance with the teachings of the present invention are shown. The second embodiment 10' of the control terminal implemented in accordance with the teachings of the present invention illustrated in fig. 1b includes a housing 12' which is ergonomically designed for allowing the person holding and operating the control terminal 10' to simply depress one key at a time by means of the thumb. The control terminal 10' includes two keys 22' and 24' similar to the keys 22 and 24 described above and further four keys 26', 28', 30' and 32' similar to the keys 26, 28, 30 and 32 described above. As distinct from the above-described first embodiment of the control terminal 10, the control terminal 10' shown in fig. 1b includes no keys similar to the keys 34 and 36 described above. Like the above described first embodiment 10 of the control terminal implemented in accordance with the teachings of the present invention, the second embodiment 10' also includes a cable 18' which is connected to the housing 12' through a bushing 20'. It is to be realised that the keys 22', 24', 26', 28', 30' and 32' like the keys 22, 24, 26, 28, 30, 32, 34 and 36 of the first embodiment 10 described above may be connected through a set of wires or as mentioned above through a printed circuit board to the individual cores of a multicore cable constituting the cable 18' and similarly the cable 18. Alternatively, a multiplexing circuit may be included in the control terminal which multiplexer circuit may convert the signal generated through the operation of one of the keys of the control terminal into a frequency multiplex signal or alternatively a time divisional multiplex signal in which case the cable such as the cables 18 and 18' of the first and second embodiment 10 and 10', respectively, may be substituted by a two-wire or coax cable rather than a multicore cable.

**[0031]** In fig. 1c, a third embodiment of the control terminal is shown designating the reference numeral 10". The control terminal 10" also includes a housing

12" composed of two housing parts 14" and 16". Further like the above-described first and second embodiments, a cable 18" is connected to the housing 12" through a bushing 20". The third embodiment 10" further includes an eyelet 19 positioned at the opposite end of the housing 12" relative to the cable 18", i.e. at the top end of the housing 12". The eyelet 19 serves the purpose of allowing a person holding and operating the control terminal 10" to position the terminal 10" in a hanging position on the bed as the control terminal 10" may be easily hung on a hook or a similar device having the hook received within the eyelet of the control terminal. At the upper surface of the top housing part 14" of the housing 12", six manually operable keys are provided designated the reference numerals 22", 26", 28", 30", 32" and 34". These keys generally serve the same purpose as the keys described above in connection with the description of the control terminal 10 and no detailed discussion of these keys are therefore presented. It is to be realised that the components and elements of the second embodiment 10' of the control terminal described above with reference to fig. 1b and similarly the components and elements of the third embodiment of the control terminal 10" described above with reference to fig. 10c serving the same purpose as components and elements, respectively, described in greater details with reference to fig. 1a are designated the same integer reference, however added a marking or alternatively the marking " for indicating the similarity and correspondence with the previously described elements shown in fig. 1a.

**[0032]** In fig. 2, a schematic and diagrammatic view is shown illustrating the transformation of the signals generated through the operation of the keys 26, 28, 30, 32, 34, 36, 22 and 24 into control signals addressing a central control means 50 such as a microprocessor having appropriate input-output interfaces through which the microprocessor 50 communicates with a total of 4 actuators A, B, C and D.

**[0033]** In fig. 3, the actuators A, B, C and D are shown in connection with a bed 60. The bed 60 comprises an exterior frame mentioned above and designated the reference numeral 62 which exterior frame is connected to the actuator D which actuator serves the purpose of raising or lowering the exterior frame 62 and in doing so also raising and lowering the bed frame of the bed which bed frame is composed of four sections 64, 66, 68 and 70. On top of the bed frame, a mattress 72 is positioned. In fig. 3, the bed frame section 64 constitutes a first section on which the person's back and head is resting and which first section is acted upon by the actuator A for raising or lowering the first bed frame section 64 relative to the adjacent or second bed frame section 64. The second bed frame section 66 is rigidly connected to the exterior frame 62 and as indicated above linked to the first bed frame section 64 and further linked to a third bed frame section 68. The second bed frame section 66 serves the purpose of supporting the person's buttocks

whereas the third bed frame section 68 serves the purpose of supporting the person's thigh. The third bed frame section 68 is acted upon by the actuator B for raising and lowering the third bed frame section 68 and is further linked to the fourth bed frame section 70 on which the actuator C acts. The fourth bed frame section 70 serves the purpose of supporting the person's crux and feet. In fig. 3, the reference signs 74 and 76 designate to control terminals which are rigidly connected to the bed frame sections 64 and 68, respectively, and which control terminals may be operated by the person sitting or lying in the bed or alternatively by a person standing next to the bed. The control terminals 74 and 76 may operate in parallel with the remote control terminal 10 shown in fig. 1a or alternatively constitute parts of a remote control terminal system as the one part such as the part 74 which part is easily operated by the person sitting or lying in the bed allows for the positioning of the bed frame sections 64, 66, 68, 70 in two specific positions, exclusively, whereas the part 76 which part is to be operated by the person standing by the bed and normally constituted by a person nursing the individual lying or sitting in the bed allows for the positioning of the bed in all relevant positions or only a limited number of specific positions. Through the division of the possible positions in which the bed frame section may be positioned into one part operated by means of the remote control terminal part 74 and another part which is operated by means of the remote control terminal part 76, it may further from a safety precaution point of view be ensured that the person sitting or lying in the bed does not unintentionally position the bed frame sections in the most extreme positions which might else cause injury or harm to the person or individual.

**[0034]** Now returning to fig. 2, the key 26 is shown together with a switch 26<sub>1</sub> which switch serves the purpose of supplying a positive voltage such as +5 VDC present from a positive supply line 40 to a set of addressing 1/0 or high/low input channels of the microprocessor 50. The microprocessor 50 includes four sets of input lines constituting lines for the addressing of the actuators A, B, C and D for causing the actuators to raise or lower the corresponding bed frame sections. Provided the key 26 is depressed actuating the switch 26<sub>1</sub>, a positive voltage signal constituting a logical high is supplied to the line high or 1 of the input addressing terminals belonging to the actuators A, B and C through three diodes 42, 44 and 46. As is evident from fig. 2, the input lines 1 and 0 belonging to the actuator D are not addressed through the depression of the key 26 and the switching of the switch 26<sub>1</sub>. Through the supply of the logical 1 to the logical high or 1 input lines of the microprocessor 50 belonging to the actuators A, B and C, the microprocessor is addressed for supplying electric power to the actuator A, B and C for establishing the position schematically illustrated on the key 26 and corresponding to the setting or reading position. Through the supply of the logical 1 to the three logical 1 input lines belonging

to the three actuators A, B and C, the microprocessor irrespective of the original position of the four bed frame sections 64, 66, 68 and 70 operate the actuators A, B and C for positioning the three operable bed frame sections 64, 68 and 70 through the supply of power to the actuators A, B and C for establishing the position of the bed frame sections 64, 66, 68, 70 illustrated schematically on the key 26 and also illustrated in fig. 3.

**[0035]** The microprocessor 50 includes internally a program representing the final position of the bed frame sections 64, 68 and 70 as represented in fig. 3 and also as is well known in the art includes limiting programmes preventing any person operating the control terminal 10 from shifting any of the bed frame sections or the exterior bed frame 62 to a position which might cause injury to the person lying or sitting in the bed. Provided the key 28 is operated, a switch 28<sub>1</sub> supplies power through three diodes similar to the diodes 42, 44 and 46 described above to the logical low input lines belonging to the actuators A and B and to the logical high input line belonging to the actuator C for causing the first and third bed frame sections 64 and 68, respectively, to be lowered to a horizontal position and for causing the fourth bed frame section 70 to be raised to the horizontal position.

**[0036]** A further switch 30<sub>1</sub> belonging to the key 30 supplies power to the logical 1 input lines belonging to the actuators A and C and also supplies power to the logical low input line belonging to the actuator B for causing the actuator A to raise the first bed frame section 64 and similarly raise the fourth bed frame section 70 through the supply of power to the actuators A and C and cause the actuator B to lower the third bed frame section 68 and in doing so establishing the sitting position illustrated on the key 30 in which the bed frame section 66, 68 and 70 are positioned in an overall horizontal orientation whereas the first bed frame section 64 is raised.

**[0037]** A further switch 32<sub>1</sub> belonging to the key 32 supplies power through respective diodes to the logical high input line belonging to the actuator B and to the logical low input lines belonging to the actuators A and C for causing the actuator B to raise the third bed frame section 68 and for causing the actuators A and C to lower the first bed frame section and the fourth bed frame section 70, respectively, as the first bed frame section 64 is positioned in an overall horizontal orientation.

**[0038]** Two additional switches 34<sub>1</sub> and 36<sub>1</sub> are provided belonging to the keys 34 and 36, respectively, for allowing the person holding and operating the remote control terminal 10 to cause the actuator C to raise or alternatively lower the fourth bed frame section 10 as the logical 1 and the logical 0 input line, respectively, belonging to the actuator C are addressed through respective diodes connected to the switches 34<sub>1</sub> and 36<sub>1</sub>, respectively.

**[0039]** In fig. 2, two additional switches 22<sub>1</sub> and 24<sub>1</sub> are provided belonging to the keys 22 and 24 for ad-

ressing the logical 1 and the logical 0 input line, respectively, belonging to the actuator D for causing the actuator D to raise or alternatively lower the exterior frame 62 as is discussed and described above.

**[0040]** It is to be understood that the input lines or channels of the microprocessor 50 shown in Fig. 2 along with the addressing diodes such as the diodes 42, 44, and 46 may be integrated into the interface on input block of the microprocessor 50.

**[0041]** In fig. 4, a further embodiment 10<sub>3</sub> of the remote control terminal implemented in accordance with the teachings of the present invention is shown constituting a wireless remote terminal. The wireless remote control terminal 10<sup>iii</sup> may constitute a terminal which allows for the transmission of signals from the remote control terminal to the microprocessor 50 exclusively through an interface block 48 or alternatively may constitute a remote control terminal including a display for the presentation of information received from the microprocessor 50 to the person holding and operating the remote control terminal in which case the wireless link between the remote control terminal 10<sub>3</sub> and the microprocessor is established as a bi-directional or duplex link. The wireless communication may be established as is well known in the art through ultrasonic transmission, through infrared transmission or radio transmission.

**[0042]** Although the present invention has been described above with reference to a number of presently preferred embodiments, it is to be contemplated that the present invention is by no means limited to the above described embodiments as numerous modifications and amendments obvious to a person having ordinary skill in the art may readily be deduced based on the above disclosure and also the common knowledge of the technician.

## Claims

1. A bed comprising a bed frame divided into a plurality of sections constituting individual sections f or supporting the back or the head of a person lying on or sitting in the bed, for supporting the person's buttocks, for supporting the person's thigh, and for supporting the person's crus and feet, connector means linking the bed frame sections together in a continuous bed frame structure and allowing the individual bed frame section to pivot relative to the adjacent bed frame section, a further plurality of actuator means for raising or lowering the respective bed frame section relative to the adjacent bed frame section through pivoting the respective bed frame section relative to the adjacent bed frame section, control means communicating with and controlling the actuator means through the supplying of addressing orders to the actuator means, and a remote control terminal communicating with the con-

- trol means and including a set of manually operable switch means, each individual switch means representing a specific position of each of the bed frame sections of the plurality of bed frame sections and each switch means of the set of switch means transmitting a specific order to the control means when the switch means in question is manually actuated and the control means transforming the specific order into a set of addressing orders supplied to the actuator means of the further plurality of actuators means for establishing a shift of the position of the individual bed frame sections into the position represented by the switch means in question.
2. The bed according to claim 1, the further plurality of actuator means being identical to the plurality of bed frame sections as each bed frame section includes a single actuator means, or alternatively, the further plurality of actuator means being different from the plurality of bed frame sections as at least one of the bed frame sections includes more than one actuator means or alternatively includes no actuator means.
  3. The bed according to any of the claims 1 or 2, the control means comprising a central computer means including a limit programme for preventing the actuator means from raising or lowering the bed frame sections beyond specific allowable limits and receiving feedback information from separate detectors of the individual bed frame sections or from the actuator means representing the actual positions of the individual bed frame sections.
  4. The bed according to any of the claims 1-3, the remote control terminal being constituted by a handheld control terminal connected to the control means through a cable connection or through a wireless link for the transmission of the specific orders representing the individual positions represented by the switch means through a multicore cable connection, in a multiplexed signalling mode, in a radio transmission link or an optical transmission link, or alternatively, the remote control terminal being constituted by a PC communicating with the control means through a parallel or serial link such as a local or public network.
  5. The bed according to any of the claims 1-4, further comprising an additional, exterior frame in which the bed frame is journaled.
  6. The bed according to claim 5, the exterior frame comprising a head and a footboard and the exterior frame being journaled or supported on an underframe.
  7. The bed according to claim 6, the exterior frame being raisable or lowerable relative to the underframe
- by means of separate actuators.
8. The bed according to any of the claims 1-7, the remote control terminal further includes one or more switch means for ordering a specific actuator to raise or lower a specific bed frame section, or for establishing a tilt position of the bed frame
  9. The bed according to any of the claims 1-8, the actuator means being constituted by low voltage electric motors including linear displaceable rods or arms.
  10. A remote control terminal for use in connection with a bed comprising a bed frame divided into a plurality of sections constituting individual sections for supporting the back or the head of a person lying on or sitting in the bed, for supporting the person's buttocks, for supporting the person's thigh, and for supporting the person's crus and feet, connector means linking the bed frame sections together in a continuous bed frame structure and allowing the individual bed frame section to pivot relative to the adjacent bed frame section, a further plurality of actuator means for raising or lowering the respective bed frame section relative to the adjacent bed frame section through pivoting the respective bed frame section relative to the adjacent bed frame section, and control means communicating with and controlling the actuator means through the supplying of addressing orders to the actuator means, the remote control terminal having a communication link being a wire connection or a wireless link for communicating with the control means of the bed and including a set of manually operable switch means, each individual switch means representing a specific position of each of the bed frame sections of the plurality of bed frame sections and each switch means of the set of switch means transmitting a specific order through the communication link to the control means when the switch means in question is manually actuated for causing the control means to transform the specific order into a set of addressing orders supplied to the actuator means of the further plurality of actuators means for establishing a shift of the position of the individual bed frame sections into the position represented by the switch means in question.

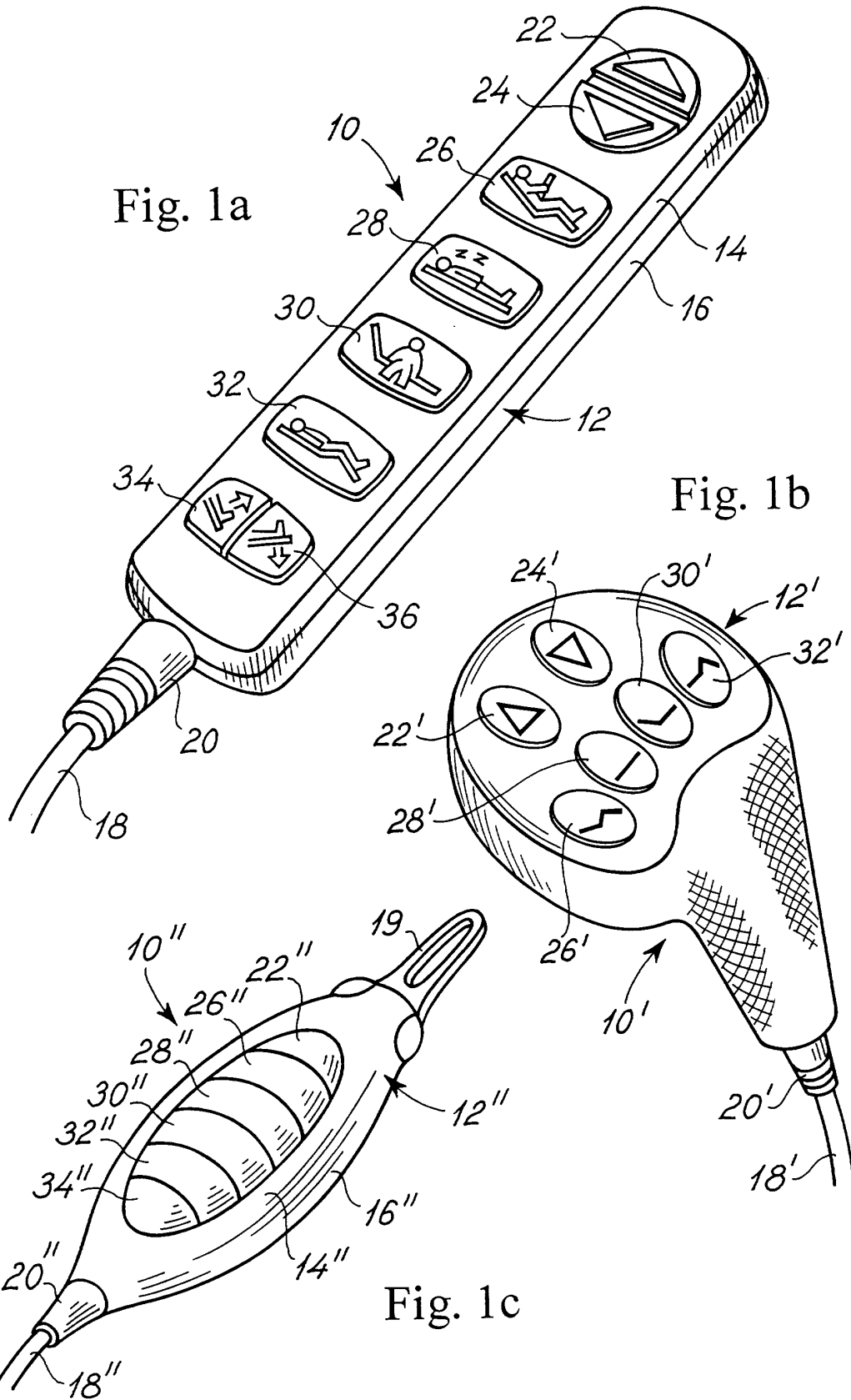

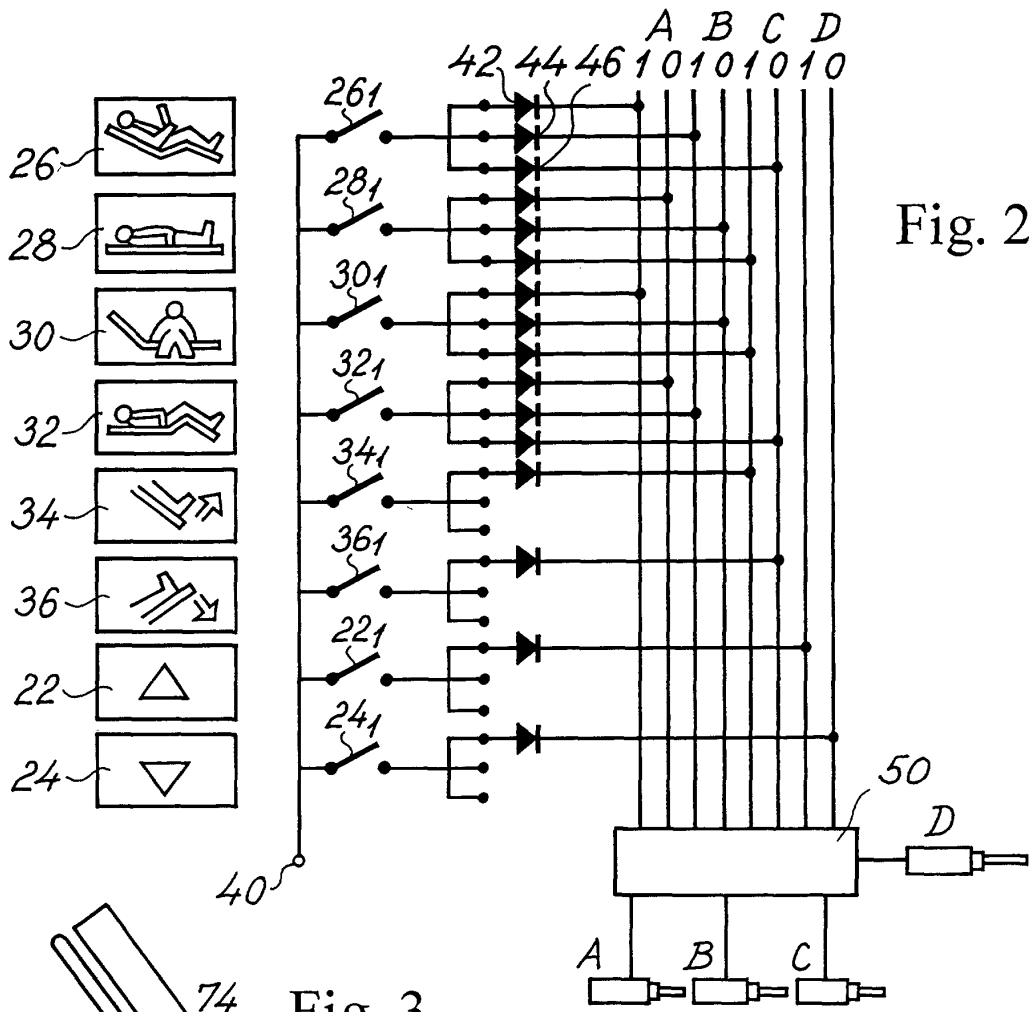

Fig. 2

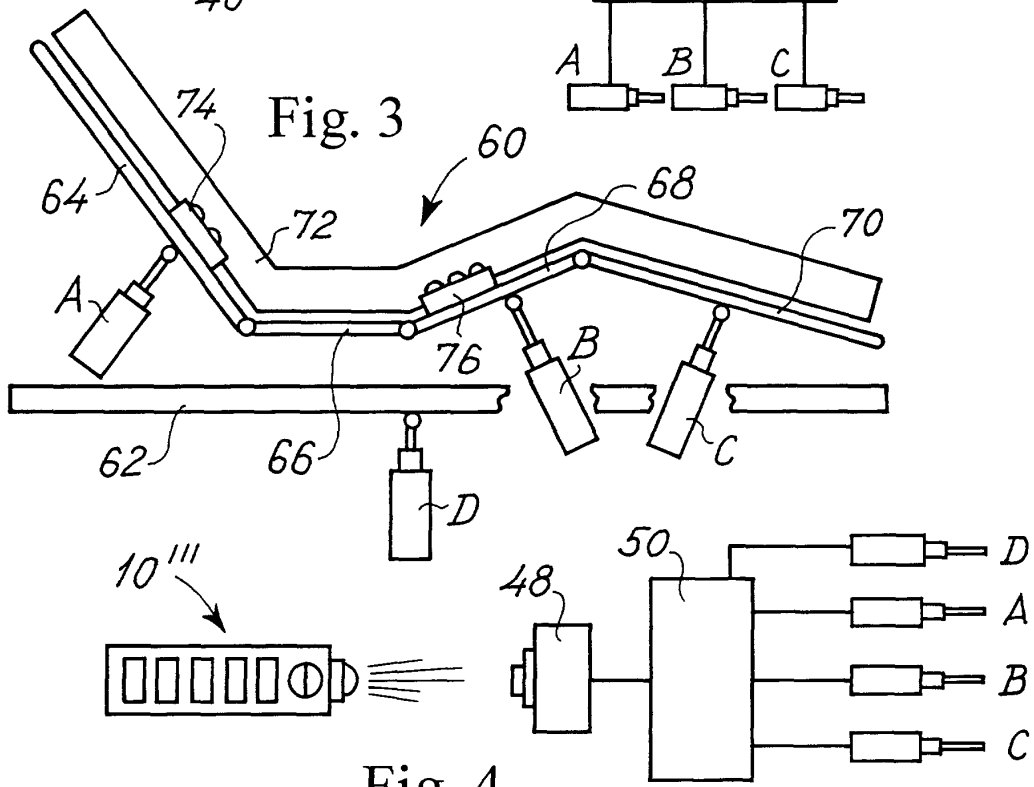

Fig. 3

Fig. 4



European Patent  
Office

## EUROPEAN SEARCH REPORT

Application Number  
EP 00 61 0088

DOCUMENTS CONSIDERED TO BE RELEVANT			
Category	Citation of document with indication, where appropriate, of relevant passages	Relevant to claim	CLASSIFICATION OF THE APPLICATION (Int.Cl.7)
X	DE 94 20 495 U (ARNOLD L & C) 30 March 1995 (1995-03-30)	1, 2, 4-8, 10	A61G7/018
Y	* page 4, line 11 - line 14 *	3	
A	* page 9, line 21 - page 10, line 4; figures *	9	
----			
X	DE 298 15 699 U (SCHMITZ U SOEHNE GMBH & CO KG) 27 May 1999 (1999-05-27)	1, 2, 4, 8, 10	
A	* page 8, line 6 - line 17; figures *	3, 5-7, 9	
----			
Y	US 5 600 214 A (FROMSON LEONARD E) 4 February 1997 (1997-02-04)	3	TECHNICAL FIELDS SEARCHED (Int.Cl.7)  A61G H01H
A	* column 8, line 17 - line 33; figures *	9	
----			
A	FR 2 696 384 A (FAURE BERTRAND AUTOMOBILE) 8 April 1994 (1994-04-08)	3, 4, 8, 9	
----			
A	DE 298 02 346 U (SIEMENS AG) 23 April 1998 (1998-04-23)	3, 4	
----			
A	* page 7, line 35 - page 8, line 4 * * page 8, line 22 - line 27; figures *		
----			
A	FR 2 641 424 A (KERDONCUFF FRANCOIS) 6 July 1990 (1990-07-06)	9	
* the whole document * -----			
The present search report has been drawn up for all claims			
Place of search		Date of completion of the search	Examiner
THE HAGUE		2 February 2001	Cametz, C
CATEGORY OF CITED DOCUMENTS			
X: particularly relevant if taken alone Y: particularly relevant if combined with another document of the same category A: technological background O: non-written disclosure P: intermediate document		T: theory or principle underlying the invention E: earlier patent document, but published on, or after the filing date D: document cited in the application L: document cited for other reasons &: member of the same patent family, corresponding document	

EPC FORM 1503 03.92 (P04001)

**ANNEX TO THE EUROPEAN SEARCH REPORT  
ON EUROPEAN PATENT APPLICATION NO.**

EP 00 61 0088

This annex lists the patent family members relating to the patent documents cited in the above-mentioned European search report. The members are as contained in the European Patent Office EDP file on  
The European Patent Office is in no way liable for these particulars which are merely given for the purpose of information.

02-02-2001

Patent document cited in search report	Publication date	Patent family member(s)	Publication date
DE 9420495 U	30-03-1995	NONE	
DE 29815699 U	27-05-1999	NONE	
US 5600214 A	04-02-1997	US 5544376 A US 5969488 A	13-08-1996 19-10-1999
FR 2696384 A	08-04-1994	NONE	
DE 29802346 U	23-04-1998	NONE	
FR 2641424 A	06-07-1990	NONE	

EPC FORM P0469

For more details about this annex : see Official Journal of the European Patent Office, No. 12/82