



Europäisches Patentamt
European Patent Office
Office européen des brevets



(11) **EP 1 197 437 A2**

(12) **EUROPEAN PATENT APPLICATION**

(43) Date of publication:
17.04.2002 Bulletin 2002/16

(51) Int Cl.7: **B65D 6/18**, B65D 43/16,
B65D 45/24, B65D 51/16,
B65D 81/18, B65D 81/22

(21) Application number: **01308732.5**

(22) Date of filing: **12.10.2001**

(84) Designated Contracting States:
**AT BE CH CY DE DK ES FI FR GB GR IE IT LI LU
MC NL PT SE TR**
Designated Extension States:
AL LT LV MK RO SI

(72) Inventors:
• **Uke, Alan**
Poway, California 92064 (US)
• **Arnett, Jeffrey**
Fallbrook, California 92028 (US)
• **Thomas, Matthew**
La Mesa, California 91941 (US)

(30) Priority: **23.07.2001 US 911928**
12.10.2000 US 689001

(74) Representative: **Beck, Simon Antony et al**
Withers & Rogers,
Goldings House,
2 Hays Lane
London SE1 2HW (GB)

(71) Applicant: **Underwater Kinetics, Inc.**
Poway, California 92064 (US)

(54) **Shock-resistant and environmentally sealed container with pressure equalization**

(57) A shock-resistant and environmentally sealed container with pressure equalization is provided. A latch is pivotally coupled to the container and has an open position and a closed position. An air passageway is provided that permits air to pass between the interior of the container and the surrounding atmosphere. Several different elements are disclosed that are positioned in the air passageway. These elements are designed to cooperate with the latch so that when the latch is in the closed position, the element seals the air passageway and when the latch is in the open position, air is allowed to pass through the air passageway and equalize any air pressure differentials.

A latching system for the container may also include a deflectable pin coupled to a first section of the container with a latch coupled to a second section. The latch includes a deflectable pin engaging member. When the deflectable pin engaging member is engaged with the deflectable pin, the deflectable pin absorbs relative movement between the first section and the second section of the container. Another embodiment of the container employs a latch containing a deflectable member. The latch is pivotally coupled to a latch pin that is mounted to either the first section or the second section of the container. The deflectable member is positioned between the latch pin and the latch, and the deflectable member is configured to absorb relative movement between the first section and the second section.

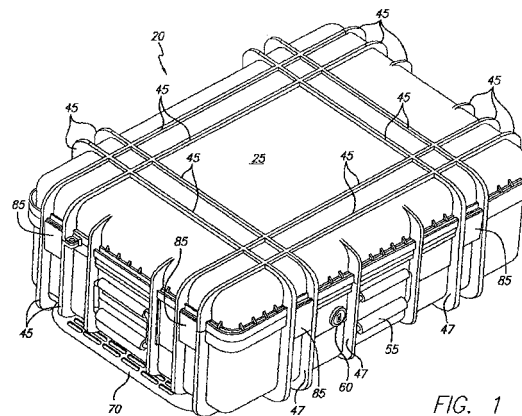

FIG. 1

Description**Field Of The Invention**

[0001] The present invention generally relates to containers. More particularly, the invention concerns containers that are both shock-resistant and environmentally sealed.

Background Of The Invention

[0002] A wide variety of containers are used everyday to transport the goods that comprise the modern global economy. An ever-increasing part of the new economy are electronic devices such as digital cameras, personal digital assistants, and other apparatus. However, containers that were previously suitable for transporting mechanical goods are not capable of safely shipping the delicate electronic devices of today. Moreover, the technology employed by the transport industry has not kept pace with the goods it transports. For example, shipping containers continue to be dropped by careless handlers and goods shipped overseas are subjected to a host of adverse environmental conditions.

[0003] In response, electronics and other manufacturers are demanding new containers that can survive drop tests and pressure tests, that are aimed at protecting their products from high humidity, moisture and the severe impacts that can occur during shipment.

[0004] However, the new containers have several shortcomings. For instance, containers designed to be airtight and waterproof employ a sealing ring to seal the container. When the container is closed, the sealing ring is partially compressed. However, upon impact, the seal compresses completely, which allows the latches to loosen, resulting in a container that opens unexpectedly. In addition, the severe impact tests also destroy container hinges which cause the containers to break apart. Additional problems include damage to handles, latches and other components located on the exterior of the containers.

[0005] Therefore, a need exists for a shock-resistant, environmentally sealed container that can transport delicate goods while enduring rigorous shipping conditions.

Summary Of The Invention

[0006] In order to overcome the deficiencies with known, conventional containers, a shock-resistant and environmentally sealed container with pressure equalization is provided. Briefly, the container can include a number of unique latching systems that keep the container closed even after severe impacts. In addition, the container provides a pressure equalization system to equalize air pressure between the interior of the container and the surrounding atmosphere. Alternatively, the pressure equalization system may equalize pressure between two compartments located within a single

container.

[0007] More specifically, one embodiment of the present invention container employs a deflectable pin coupled to one section of the container and a latch coupled to a second section of the container. The latch includes a deflectable pin engaging member and when the deflectable pin engaging member is engaged with the deflectable pin, the latch system absorbs relative movement between the first section and the second section of the container. Another embodiment of the present invention employs a latch pin mounted on a first container section and a latch containing a deflectable member mounted in the latch with the latch pivotally coupled to the latch pin so that the deflectable member is positioned between the latch pin and the latch. The latch is structured to removably engage a second container section and the deflectable member is configured to absorb relative movement between the first section and the second section of the container.

[0008] The shock-resistant and environmentally sealed container of the present invention affords its users with a number of distinct advantages. First, unlike prior containers, the latches remain secured even after severe impacts. In addition, a plurality of ribs extending around the container protect the handles, latches and the top and bottom sections of the container from severe impact. In addition, a removable hinge pin is included which permits the two sections comprising the container to be completely separated from each other. This modification can be accomplished by hand, without the use of any tools.

[0009] In addition, another embodiment of the present invention employs a latch that is pivotally coupled to the container. A deflectable member is positioned in a container air passageway and located adjacent to the latch. When the latch is in a closed position, the latch seals one end of the deflectable member and prevents air from flowing through the deflectable member and the air passageway. When the latch is moved to an open position, the seal is broken and air can flow through the deflectable member and through the air passageway, thereby equalizing pressure between the surrounding atmosphere and the interior of the container.

[0010] Yet another embodiment of the present invention employs a deflectable member that is pinched by the latch. When the latch is in a closed position, a tip of the latch pinches the deflectable member and seals the air passageway. When the latch is moved to an open position, the tip of the latch rotates away from the deflectable member and the air passageway is opened.

[0011] A further embodiment of the present invention employs a slideable member positioned in an air passageway. The slideable member includes a sealing member that seals the air passageway when the latch is in a closed position. A spring member urges the slideable member against the latch, and when the latch is rotated to the open position, the slideable member is urged partially out of the air passageway, unseating the

sealing member and allowing air to flow through the air passageway.

[0012] The pressure equalization system affords its users with a number of distinct advantages. During instances when the pressure inside the container is less than the pressure outside the container, the container can be difficult to open. Advantageously, the pressure equalization system constructed according to the present invention performs pressure equalization during the container-opening procedure. When the latches are released to open the container, a seal between one of the latches and a deflectable member is broken, permitting air to flow through an air passageway and into the container. No additional steps are required to equalize air pressure between the interior of the container and the surrounding atmosphere.

Brief Description Of The Drawings

[0013] The nature, goals, and advantages of the invention will become more apparent to those skilled in the art after considering the following detailed description when read in connection with the accompanying drawing in which like reference numerals identify like elements throughout wherein:

FIG. 1 is a perspective view of one embodiment of the shock-resistant and environmentally sealed container;

FIG. 2 is a perspective view of the embodiment of FIG. 1 showing the bottom of the container;

FIG. 3 is an elevation view of a front side of the container illustrated in FIG. 1;

FIG. 4 is an elevation view of the hinge side of the container illustrated in FIG. 1;

FIG. 5 is a sectional view taken along cutting plane 5--5 of FIG. 3;

FIG. 6 is a perspective view of one embodiment of a latch used to secure the container illustrated in FIG. 1;

FIG. 7 is a side view of the latch illustrated in FIG. 6;

FIG. 8 is a side elevation sectional view of the latch illustrated in FIG. 6 attached to the container illustrated in FIG. 1;

FIG. 9 is an elevation view of the latch and surrounding area illustrated in FIG. 8;

FIG. 10 is a side elevation sectional view of an alternative embodiment latch that secures the container illustrated in FIG. 1;

FIG. 11 is an elevation view of the latch illustrated in FIG. 10;

FIG. 12 is a sectional view taken along cutting plane 12--12 of FIG. 4;

FIG. 13 is a perspective view of the container illustrated in FIG. 1 showing the extendable handle;

FIG. 14 is a perspective view of the extendable handle illustrated in FIG. 13;

FIG. 15A is a side elevation sectional view of an alternative embodiment of the present invention incorporating one embodiment of a pressure equalization system;

FIG. 15B is a side elevation sectional view of the pressure equalization system illustrated in FIG. 15A;

FIG. 16 is an elevation view of the pressure equalization system illustrated in FIG. 15A;

FIG. 17A is a side elevation sectional view of yet another embodiment of the present invention incorporating an alternative embodiment pressure equalization system;

FIG. 17B is a side elevation sectional view of the pressure equalization system illustrated in FIG. 17A;

FIG. 18A is a side elevation sectional view of another embodiment of the present invention incorporating yet another embodiment of a pressure equalization system;

FIG. 18B is a side elevation sectional view of the pressure equalization system illustrated in FIG. 18A; and

FIG. 19 is an elevation view of yet another embodiment latch that secures the container illustrated in FIG. 1.

[0014] It will be recognized that some or all of the Figures are schematic representations for purposes of illustration and do not necessarily depict the actual relative sizes or locations of the elements shown.

Detailed Description Of The Invention

[0015] In the following paragraphs, the present invention will be described in detail by way of example with reference to the attached drawings. Throughout this description, the preferred embodiment and examples shown should be considered as exemplars, rather than

as limitations on the present invention.

[0016] Referring to FIGS. 1 and 2, a shock-resistant and environmentally sealed container 20 in accordance with the present invention is illustrated. As defined herein, a "container" comprises any enclosed volume that can hold other objects within itself, such as receptacles, canisters, tanks, chests, trunks, and other devices.

[0017] One embodiment container 20 generally comprises a substantially rectangular receptacle for holding delicate or fragile objects. Other configurations, such as substantially cylindrical, or other suitable configurations are also contemplated. The container 20 is shock-resistant and is configured to absorb substantial impacts. The container 20 is also environmentally sealed and therefore is waterproof and airtight. As used herein, waterproof means the container 20 is highly resistant to penetration by water into the interior of the container 20 when it is closed. In addition, as used herein airtight means the container 20 is highly resistant to penetration by air into the interior of the container 20 when it is closed. The container 20 incorporates several unique features that permit it to securely transport delicate and fragile objects without the risk of opening as result of mishandling or inadvertent accidents.

[0018] FIGS. 1-4 illustrate a container 20 having a top or first section 25 and a bottom or second section 30. The container 20 is substantially rectangular, but it will be appreciated that other container shapes, such as squares or more elongated rectangles, may also be constructed using principles according to the present invention. In the illustrated embodiment, eight ribs 45 extend around the outer surface of the container 20. Additional rib portions 45 also extend along the sides of the container 45. For example, illustrated in FIG. 3 the front side 35 has six rib portions 45. Shown in FIG. 4, the hinge side 40 of the container 20 has four rib portions 45. It will be appreciated that the number of ribs 45 can vary depending upon the strength requirements and aesthetic requirement of the container 20. In a preferred embodiment, the ribs are molded integrally into the first and second sections 25 and 30, respectively. The container 20, including ribs 45, is injection-molded using acrylonitrile-butadiene-styrene (ABS). It will be appreciated that other types of plastics or other composite materials can be used to manufacture the container 20. Ribs 45 add structural strength to the container by increasing the bending and torsional stiffness of the container 20. In addition, as illustrated in FIGS. 1 and 2, the ribs extend past the latches 85, handles 55 and other objects positioned on the outside of the container 20, thereby protecting these objects from damage.

[0019] Referring now to FIGS. 3 and 5, the ribs 45 in conjunction with overlapping tabs 27 keep the first section 25 from being torn-off or otherwise removed from the second section 30 during impacts. Overlapping tabs 27 are connected to the first section 25 and overlap over the second section 30. Shown in FIG. 5, parting line 32 defines the meeting point of first section 25 and second

section 30. Overlapping tab 27 extends over the parting line 32 from the first section 25 over the second section 30. Referring now to FIG. 3, the overlapping tabs 27 closely abut the rib sides 47. The distance between the rib sides 47 and the overlapping tabs 27 can range from about 0.01 inches to about 0.1 inches. When the container 20 is dropped or otherwise mishandled and encounters a force on load on the first section 25, that load is transferred to the second section 30 through the overlapping tabs and into the ribs sides 47. In this manner, the rib sides 47 support the first section 25 and keep the first section 25 from deflecting relative to the second section 30. This ensures that the first section 25 remains securely attached to the second section 30 thereby keeping the container 20 environmentally sealed even under severe impact loads.

[0020] Referring now to FIGS. 6-9, a latch 85 constructed in accordance with the present invention is illustrated. Latch 85 includes a bushing 95 located in a cylindrical cavity 87 of latch 85. One embodiment of the bushing 95 comprises a cylindrically-shaped bushing having an outer surface comprised of a series of projections running along the longitudinal-axis of the bushing 95. It will be appreciated that other versions of the bushing 95 could be employed such as one or more bushings positioned within the cylindrical cavity 87 of the latch 85. Bushing 95 has a central aperture extending along its longitudinal axis which is sized to receive a latch pin 100, shown in FIGS. 8 and 9. In one embodiment, latch pin 100 is mounted in first section 25, but it will be appreciated that the latch pin 100 could be mounted in the bottom section 30. That is, the orientation of latch 85 may be reversed. Latch 85 is pivotally coupled to the first section 25 by the latch pin 100 which is inserted through the bushing 95. When the container 20 is closed, latch 85 can be rotated about the latch pin 100 so that latch locking ridge 110 frictionally engages the container locking ridge 115, shown in FIG. 8. In this manner, the two container sections 25 and 30 are securely held together. When desired, the container 20 can be opened by pulling on the finger grip 105 and releasing the latch 85 from the container locking ridge 115 and pivoting the latch 85 about the latch pin 100. Advantageously, latch pin 100 is mounted in a double-shear arrangement in ribs 45, resulting in an extremely strong and durable latch 85 mount.

[0021] Referring now to FIG. 8, gasket 120 is positioned between the first section 25 and the second section 30 of the container 20. In one embodiment the gasket 120 resides in a recessed channel in the first section 25, but it will be appreciated that the gasket 120 can also be located in the second section 30. Gasket 120 creates an airtight and waterproof seal by sealing the first section 25 to the second section 30. In a preferred embodiment gasket 120 is made of a soft rubber or plastic material and has a substantially D-shaped cross-section with a hollow center section. However, it will be appreciated that solid gasket or gaskets of other cross-section

tions such as O-rings can be employed.

[0022] Referring now to FIG. 8, one advantage of the present invention is illustrated. When a force or load is exerted against the top section 25 of the container 20, such as when the container 20 is dropped, the top section 25 presses against the bottom section 30, compressing gasket 120. Latch pin 100, which is also connected to first section 25 compresses bushing 95 as the top section 25 is forced against the bottom section 30. In contrast to conventional latch systems that are rigidly mounted, and that would release and allow the container 20 to open, the latch system of the present invention can absorb the load and keep the latch 85 securely engaged. This is because bushing 95 deflects, as shown in FIG. 8, allowing the latch pin 100 to shift in the cylindrical aperture 87 of the latch 85. Because the bushing 95 deflects, the latch 85 does not move, keeping the latch 85 securely engaged with the second section 30 of the container 20. Another advantage of the present invention is that the bushing 95 frictionally engages the latch pin 100, creating a rotational resistance in latch 85. Because latch 85 does not freely rotate about latch pin 100, when the latch 85 is released and the container 20 is opened the latch 85 remains in an open position keeping the finger grip 105 from contacting the parting line 32 when the container 20 is closed.

[0023] Referring now to FIGS. 10-11, an alternative embodiment latching system in accordance with the present invention is illustrated. In this embodiment, military latch 90 is employed to secure the first section 25 of the container 20 to the second section 30. The military latch 90 is a conventional latch used for military applications and meets military specifications. The military latch 90 employs a twist tab 92 that pulls pin engaging member 97 downward into the latch 90 when the twist tab 92 is twisted by an operator. In this manner the first section 25 is firmly held against the second section 30, tightly sealing the container 20. However, the military latch 90 is comprised of several individual elements and each element has its own manufacturing tolerance. During assembly these elements having different tolerances, or dimensions are combined creating military latches 90 having different sizes. For example, the pin engaging member 97 may be slightly longer than another pin engaging member 97 and twist tab 92 may not pull in the engaging member 97 as far as military latch 90 as another military latch 90, hereby creating a clamping difference between military latches 90. One advantage of the present invention is the use of a latch pin 100 that deflects, thereby absorbing the manufacturing tolerances of the military latch 90. Illustrated in FIG. 11, latch pin 100 is engaged by the pin engaging member 97 and when twist tab 92 is rotated by an operator the latch pin 100 deflects, closing the container 20. The deflection of the latch pin 100 absorbs the manufacturing tolerances in contrast to prior latching systems that permitted the military latch 90 to release inadvertently during shipment. In addition, the latch pin 100 absorbs the com-

pression of the gasket 120 when the container 20 encounters impacts or loads. As discussed above, the gasket 120 can compress during severe impacts causing the first section 25 and second sections 30 to compress together creating slack in the military latches 90. The deflectable latch pin 100 absorbs this slack keeping the military latch 90 secured about the latch pin 100 and keeping the container 20 closed. Also shown in FIGS. 10-11 is deflectable pin stop 94. The deflectable pin stop 94 acts as a support or deflection limiting member to the deflectable latch pin 100. When severe impacts are encountered by the container 20, the first section 25 and the second section 30 can move relative to each other causing the latch pin 100 to deflect. Under extreme impacts, the deflectable latch pin 100 may deflect to the point where pin engaging member 97 disengages from the deflectable latch pin 100, allowing the container 20 to open. With the deflectable pin stop 94 positioned adjacent to the deflectable latch pin 100, the total amount of deflection of the latch pin 100 is limited. Limiting the deflection of the latch pin 100 keeps the pin engaging member 97 of the military latch 90 firmly engaged with the latch pin 100 even under extreme impacts. As shown in FIG. 11, when a load is encountered, the latch pin 100 deflects contacting deflectable pin stop 94, thereby limiting the deflection of the latch pin 100 and ensuring that the pin engaging member 97 remains attached to the deflectable latch pin 100. Preferably, latch pin 100 is made of tempered spring-steel. It will be appreciated that other types of materials can be used to make latch pin 100 so that it can deflect and spring back into position. In one embodiment latch pin 100 is about 0.175 inches in diameter, and can be easily replaced by pushing the latch pin 100 through ribs 45.

[0024] Advantageously, container 20, constructed according to the present invention, can accept either the military latch 90 or the latch 85, without change to the structure of the container 20.

[0025] Referring to FIG. 19, a bent-arm latch pin 200 is illustrated. As discussed above, the latch pin 100 illustrated in FIG. 11 is slideably positioned in ribs 45. During severe impacts or during periods of extended vibration, the latch pin 100 can migrate, or move within the ribs 45. During extremely severe impacts or extremely extended periods of vibration, the latch pin 100 can migrate completely out of the ribs 45. To eliminate the possibility of having the latch pin 100 disengage from one of the ribs 45, a bent-arm latch pin 200 is provided. As shown in FIG. 19, each bent-arm latch pin 200 includes two bent-arm pin ends 205. Each military latch 90 requires two bent-arm latch pins 200, one coupled to the first section 25 and another coupled to the second section 30 of the container 20. As can be seen in FIG. 19, the bent-arm pin ends 205 cannot migrate out of the first section 25 or second section 30 because the military latch 92 clamps them into position. That is, when the military latch 90 is secured around the bent-arm pins 200, the clamping force of the military latch 90 keeps

the bent-arm pin ends 205 from disengaging from their locations in first section 25 and second section 30.

[0026] As discussed above in connection with the latch pin 100, the bent-arm latch pin 200 is designed to deflect under load and absorb relative movement between the first section 25 and second section 30 of the container 20. In one embodiment, the bent-arm latch pin 200 is about 0.175 inch in diameter, and is preferably constructed of tempered spring-steel. It will be appreciated that other types of materials can be used to make the bent-arm latch pin 200 so that it can deflect under load, yet return to its original shape.

[0027] Referring now to FIGS. 2 and 4, a hinge 50 constructed in accordance with the present invention is illustrated. The hinge comprises an elongated rod 52 that is positioned in a plurality of rod receivers 54. The rod receivers 54 are alternatively mounted on the first section 25 and on the second section 30 and are sized to slideably receive the elongated rod 52. One advantage of the present invention is that elongated rod 52 can be easily removed from the rod receivers 54 thereby allowing the first section 25 to be completely separated from second section 30. In this manner, the individual sections can be used to carry the contents of the container 20 or the separate sections can be separated for efficient storage.

[0028] Referring now to FIG. 12, locking means for securing the elongated rod 52 to the second section 30 are illustrated. A rod detent 56 is located on the second section 30 of the container 20 and when the elongated rod 52 is inserted into all of the rod receivers 54 the elongated rod end is pivoted so that it engages the rod detent 56 securely. Advantageously, inserting the elongated rod 52 into the rod detent 56 can be performed by hand, yet the arrangement permits the elongated rod 52 to remain secure even under the most severe shipping impacts. In this manner, the container 20 remains intact under strenuous conditions, yet can be easily separated into first 25 and second 30 sections for use by the operator. It will be appreciated that the rod detent 56 can also be located in the first section 25. In a preferred embodiment the elongated rod 52 is metal, but it will be appreciated that other materials can be employed.

[0029] Referring now to FIGS. 15A-16, a pressure equalization system is illustrated. Because the container 20 is airtight, conditions may arise where the pressure inside the container is less than the pressure outside the container and an operator will not be able to open the container 20 because of the pressure differential. For example, if the container 20 is filled with goods at a manufacturing facility located at 5,000 above sea level, then shipped to a receiving facility at sea level, a significant pressure differential will exist between the interior of the container 20 and the exterior of the container 20. In this situation it will be extremely difficult, if not impossible, to open the container 20 as a result of the higher pressure outside the container 20 relative to the lower pressure inside the container 20.

[0030] To address this pressure differential problem, the present invention includes a pressure equalization system. As shown in FIGS. 15A and 15B, the pressure equalization system includes a deflectable member 150 located in an air passageway 140. The deflectable member 150 includes an aperture 155 positioned along the longitudinal axis of the deflectable member 150. The aperture 155 permits the passage of air from the interior of the container 20 to the atmosphere, and vice-versa. The deflectable member 150 is located within the air passageway 140 and rests against a step 145. The deflectable member 150 is sized to extend beyond the outer surface of the container 20 so that when latch 85 is secured in the closed position, the deflectable member 150 is compressed between the latch 85 and the step 145. In this fashion, an airtight seal is formed between the latch 85 and the deflectable member 150, preventing passage of air through the aperture 155. In addition, the deflectable member 150 is compacted into the air passageway 140 by the latch 85, preventing the passage of air between the outside of the deflectable member 150 and the walls of the air passageway 140. In a preferred embodiment, the deflectable member 150 is constructed of rubber, but other types of materials, such as plastics, polyurethanes, elastomers, and other suitable materials can be employed. In a second preferred embodiment of the present invention, the deflectable member 150 remains compressible in a temperature range between -60 degrees Fahrenheit and +150 degrees Fahrenheit.

[0031] One advantage of the present invention is that pressure equalization is accomplished simply by pivoting the latch 85 away from the deflectable member 150, which occurs whenever a user wishes to open the container 20. For example, when a pressure differential exists between the interior of the container 20 and the exterior of the container 20, the container 20 may be difficult, if not virtually impossible to open. When latch 85 is pivoted about the latch pin 100, as shown in FIG. 15B, air is now allowed to pass through the aperture 155 and into the interior of the container 20. Conversely, if the air pressure inside container 20 is greater than the air pressure outside the container 20, air may pass from the interior of container 20 to the exterior through aperture 155. This pressure equalization system is activated when the latch 85 is released during the container 20 opening process. Therefore, no additional steps must be performed to equalize air pressure between the atmosphere and the interior of container 20. In this way, the container 20 will always open safely and easily.

[0032] Referring now to FIGS. 17A and 17B, an alternative embodiment pressure equalization system is illustrated. A moveable plug or slideable member 160 is slideably positioned in air passageway 140. An interior end of the moveable plug 160 includes a stop 170 that opposes a force exerted by spring 175. The spring 175 urges the moveable plug 160 against latch 85 in the closed position, as shown in FIG. 17A. In one embodi-

ment, stop 170 is comprised of a "C"-ring, but other suitable devices can be employed. When latch 85 is the closed position, the spring 175 is compressed and the air passageway 140 is sealed by sealing member 165. In one embodiment, the sealing member is an "O"-ring but other types of seals, gaskets or other suitable devices can be employed. When latch 85 is pivoted away from the container 20, spring 175 urges the moveable plug 60 outward and O-ring 165 is moved beyond step 145, as shown in FIG. 17B. Air can now pass through air passageway 140 and any air pressure difference between the interior of container 20 and the surrounding atmosphere is eliminated. An alternative embodiment of the moveable plug 160 can include one or more channels 180 to facilitate movement of air through the air passageway 140. The movement of the moveable plug 160 is limited by stop 170 which contacts the interior surface of the container 20, as shown in FIG. 17B. Similar to the pressure equalization system illustrated in FIGS. 15A-15B, no additional steps are required to equalize air pressure beyond rotating latch 85 away from the container, as would be necessary during the opening of container 20.

[0033] Referring now to FIGS. 18A and 18B, yet another embodiment of a pressure equalization system is illustrated. Positioned within air passageway 140 is tube member 185. In one embodiment, the tube member is a substantially cylindrical rubber element or other type of deflectable tube. Other types of tube shapes and materials can be employed, such as a square, rectangular or other cross-sectional member that could be constructed of rubber, plastic, polyurethane or other suitable materials. Tube member 185 is positioned adjacent to latch 85 that includes a tip 190. In the closed position, as shown in FIG. 18A, tip 190 pinches tube member 185 so that the interior of container 20 remains airtight. When latch 85 is pivoted about latch pin 100, tip 190 is rotated away from the tube member 185 and air is now allowed to flow through air passageway 140 equalizing pressure between the interior of container 20 and the surrounding atmosphere. As discussed above, no additional steps must be performed to equalize air pressure between the atmosphere and the interior of the container 20.

[0034] Another advantage of the present invention embodied in container 20 are the devices that permit easy transportation of the container 20. For example, handles 55, illustrated throughout the Figures, are positioned on all sides of the container 20 except for the hinge side 40. It will be appreciated that the handles 55 can be positioned only on one side, or on all sides including hinge side 40. Illustrated in FIG. 5, handle 55 is spring-actuated and remains positioned adjacent to the side of the container 20. Ribs 45 project past the handle 55 protecting the handle from impacts. In addition, illustrated in FIGS. 2 and 3, wheels 125 are located on the second section 30 of the container 20 enabling operators to pull or push the container 20. Wheels 125 are

mounted in the second section 30 without the use of bearings. Therefore, the wheels 125 cannot be fouled by sand or dirt. Pins (not shown) located in ribs 45 position the wheels 125 in the second section 30.

[0035] Referring now to FIGS. 2, 13 and 14, an extendable handle 70 constructed in accordance with the present invention is illustrated. Extendable handle 70 is located in the second section 30 of the container, and includes handle legs 75 that are positioned in exterior channels 77. In this manner, the container 20 remains environmentally sealed because the handle 70 does not enter the interior of the container 20. Handle covers 79 fasten to the second section 30 and locate the extendable handle 70 in the exterior channels 77. When desired, extendable handle 70 is deployed by an operator by pulling on the extendable handle 70 and releasing sliding lock 72. Shown in FIG. 13, sliding lock 72 includes a projection 84 that can be positioned by the sliding lock 72 to either align with slot guides 82 or be positioned between slot guides 82. Slot guides 82 fit into slots 80 in extendable handle legs 75. As the legs 75 slide in the slot guides 82, the projection 84 can be positioned between slot guides 82 so that the legs are fixed in a retracted position maintaining the handle 70 in this desired position. In a preferred embodiment, the handle 70 can be fixed in an extended position by engaging the projection 84 into a projection receiver 86. However, it will be appreciated that the number of projection receivers 86 can be varied to adjust the extendable height of the handle 70.

[0036] Also shown in FIGS. 13-14 a spring-mounted sphere 130 is positioned near a bottom section of the handle legs 75. In one embodiment, the sphere is a metal ball, but it will be appreciated that a pin or other deflectable member could be positioned in the bottom area of the handle leg 75. The spring-mounted sphere 130 is sized to be received into the sphere receivers 135 located in handle covers 79. The spring-mounted sphere extends into the sphere receivers 135 locking the leg 75 in either a stored position or in an extended position.

[0037] One skilled in the art will appreciate that the present invention can be practiced by other than the preferred embodiments which are presented in this description for purposes of illustration and not of limitation, and the present invention is limited only by the claims that follow. It is noted that equivalents for the particular embodiments discussed in this description may practice the invention as well.

Claims

1. A latch system for a container, the container including a first section and a second section, the latch system comprising:

a deflectable pin coupled to the first section; and

a latch coupled to the second section, the latch including a deflectable pin engaging member;

wherein the deflectable pin is configured to absorb relative movement between the first section and the second section.

2. The container latch system of claim 1, wherein the deflectable pin is configured so that when the deflectable pin engaging member engages the deflectable pin, the deflectable pin cannot be removed from the container.

3. The container latch system of claim 1, wherein the deflectable pin comprises two bent-arm ends.

4. The container latch system of claim 3, wherein when the deflectable pin engaging member engages the deflectable pin, a clamping force is generated, the clamping force pressing the bent-arm ends into engagement with the first section of the container.

5. The container latch system of claim 1, wherein the deflectable pin is mounted to the bottom section and the latch is coupled the top section.

6. The container latch system of claim 1, further including:

a deflectable pin stop positioned adjacent to the deflectable pin;

wherein the deflectable pin stop is arranged to stop the deflection of the deflectable pin.

7. The container latch system of claim 1, wherein the deflectable pin is mounted to the top section and the latch is coupled the bottom section.

8. The container latch system of claim 1, wherein the container is substantially waterproof and substantially airtight.

9. A latch system for a container, the container including a first section and a second section, the latch system comprising:

a latch pin mounted in the first section; and
a deflectable member mounted in a latch, with the latch pivotally coupled to the latch pin so that the deflectable member is positioned between the latch pin and the latch;

wherein the latch is structured to removably engage the second section, and the deflectable member is configured to absorb relative movement between the first section and the second section.

10. The latch system of claim 9, wherein the deflectable member is structured to resist relative movement between the latch and the latch pin.

11. The latch system of claim 9, wherein the deflectable member is structured to provide a means for adjusting the force required to pivot the latch about the latch pin.

12. The latch system of claim 9, wherein the deflectable member is a bushing.

13. The latch system of claim 9, wherein the deflectable member is a cylindrical bushing that includes a plurality of deflectable ribs positioned substantially parallel to a longitudinal axis of the cylindrical bushing.

14. The latch system of claim 9, wherein the deflectable member is a bushing comprised of a material selected from the group consisting of plastics, rubbers, metal alloys, aluminum alloys, and other metals.

15. The latch system of claim 9, wherein the latch system secures the first section against the second section so that the container is substantially waterproof and substantially airtight.

16. A container comprising:

a first section and a second section, the first section including a plurality of support members arranged to extend over the second section; and
a plurality of ribs located on an exterior surface of both the first and second sections;

wherein the plurality of support members are positioned between the plurality of ribs, and the support members are structured to limit relative movement between the first section and the second section.

17. The container of claim 16, wherein each rib has a side wall, and each support member is positioned between the side walls of two adjacent ribs.

18. The container of claim 17, wherein the plurality of support members contact the side walls of the plurality of ribs when a force is exerted upon at least one of the first section and the second section, thereby limiting relative movement between the first section and the second section.

19. A container comprising:

a first section and a second section;
a removable hinge pin;

a plurality of hinge pin receivers positioned on both the first section and the second section, the hinge pin receivers configured to slideably receive the hinge pin; and
 a hinge pin locking member located on at least one of the first section and the second section, the hinge pin locking member structured to keep the removable hinge pin engaged with the hinge pin receivers.

20. The container of claim 19, wherein the hinge pin locking member comprises a locking tab that is structured to frictionally engage a section of the hinge pin, so that the hinge pin can be unlocked and removed from the hinge pin receivers by hand.

21. An container of claim 19, further comprising:

a sealing element positioned between the first section and the second section, the sealing element structured to create an airtight seal between the first section and the second section; and
 a vent located in the airtight container, the vent structured to be selectively opened and closed.

22. The container of claim 21, wherein the sealing element comprises a deflectable member removably positioned in a recess located in at least one of the first section and the second section.

23. The container of claim 21, wherein the vent comprises a threaded hole and a vent cover structured to be removably threaded into the threaded hole.

24. The container of claim 19, further including:

an extendable handle slidably positioned on at least one of the first and second sections, the extendable handle including at least two legs; a locking member slidably mounted in at least one leg, the locking member structured to releaseably lock the extendable handle in at least one of an extended or stored position.

25. The container of claim 24, further including:

an attaching member structured to slidably mount the extendable handle to at least one of the first and second sections, the attaching member including at least two apertures configured to receive the locking member;

26. The container of claim 25, wherein the locking member comprises a sphere spring-mounted in an extendable handle leg, the sphere sized to be removably receivable into the apertures located in the attaching member.

27. A container including a first section and a second section, the container comprising:

deflectable latch means for releaseably coupling the first section to the second section and for absorbing relative movement between the first and second sections when the first and second sections are coupled together.

28. The container of claim 27, wherein the deflectable latch means comprises:

a deflectable pin coupled to the container; and a latch coupled to the container, the latch including a deflectable pin engaging member;

wherein the deflectable pin is configured to absorb relative movement between the deflectable pin and the deflectable pin engaging member.

29. The container of claim 27, wherein the deflectable latch means comprises:

a latch pin mounted in the first section; and a deflectable member mounted in a latch, with the latch pivotally coupled to the latch pin so that the deflectable member is positioned between the latch pin and the latch;

wherein the latch is structured to removably engage the second section, and the deflectable member is configured to absorb relative movement between the first section and the second section.

30. A container including a first section and a second section, the container comprising:

deflectable latch means for releaseably coupling the first section to the second section and for absorbing relative movement between the first and second sections when the first and second sections are coupled together;

a plurality of ribs extending around an exterior surface of both the first and second sections; a plurality of support members arranged to extend over the second section, the plurality of support members positioned between the plurality of ribs, the support members structured to limit relative movement between the first section and the second section;

a removable hinge pin;

a plurality of hinge pin receivers positioned on both the first section and the second section, the hinge pin receivers configured to slideably receive the hinge pin; and

a hinge pin locking member located on at least one of the first section and the second section, the hinge pin locking member structured to

keep the removable hinge pin engaged with the hinge pin receivers.

31. The container of claim 30, wherein the container is substantially waterproof and substantially airtight. 5
32. A pressure equalization system for a container comprising:
- a latch pivotably coupled to the container, the latch having an open position and a closed position; and 10
- a deflectable member positioned in a container air passageway and adjacent to the latch, the deflectable member including an aperture; 15
- wherein the latch is structured to contact the deflectable member and seal the air passageway when the latch is in the closed position, and when the latch is in the open position, the air passageway is unsealed. 20
33. The pressure equalization system of claim 32, wherein the latch includes a surface structured to seal one end of the deflectable member. 25
34. The pressure equalization system of claim 32, wherein the latch is structured to secure a top section of the container to a bottom section of the container. 30
35. The pressure equalization system of claim 32, wherein the air passageway extends through the container and allows air to communicate between an interior of the container and the atmosphere. 35
36. The pressure equalization system of claim 32, wherein the aperture located in the deflectable member is positioned substantially along a longitudinal axis of the deflectable member and allows air to pass through the deflectable member. 40
37. The pressure equalization system of claim 32, wherein the deflectable member is constructed of a material selected from the group consisting of: rubber, plastic, polyurethane, a combination of any of rubber, plastic and polyurethane, and other suitable materials. 45
38. The pressure equalization system of claim 32, wherein the container is substantially waterproof and substantially airtight. 50
39. The pressure equalization system of claim 32, wherein the deflectable member is cylindrical and includes an aperture positioned along a longitudinal axis of the cylinder. 55

40. A method of equalizing atmospheric pressure between an interior of a container and a surrounding atmosphere, the method comprising the steps of:

providing a deflectable member that is positioned in an air passageway in the container, the deflectable member including an aperture; positioning a latch adjacent to the deflectable member so that when the latch is in a closed position, the latch seals the air passageway; and

pivoting the latch away from the deflectable member so that air passes through the air passageway, thereby equalizing atmospheric pressure between an interior of a container and a surrounding atmosphere.

41. The method of claim 40, wherein the step of pivoting the latch away from the deflectable member is performed each time the container is opened.

42. A pressure equalization system for a container comprising:

means for providing a deflectable member that is positioned in an air passageway in the container, the deflectable member including an aperture;

means for positioning a latch adjacent to the deflectable member so that when the latch is in a closed position, the latch seals the air passageway; and

means for pivoting the latch away from the deflectable member so that air passes through the air passageway, thereby equalizing atmospheric pressure between an interior of a container and a surrounding atmosphere.

43. A pressure equalization system for a container comprising:

a latch pivotably coupled to the container, the latch having an open position and a closed position; and

a slideable member positioned in a container air passageway and adjacent to the latch;

wherein the latch is structured to contact the slideable member and the slideable member seals the air passageway when the latch is in the closed position, and when the latch is in the open position, the air passageway is unsealed.

44. The pressure equalization system of claim 43, wherein the latch includes a surface structured to contact one end of the slideable member.

45. The pressure equalization system of claim 43,

wherein the latch is structured to secure a top section of the container to a bottom section of the container.

46. The pressure equalization system of claim 43, wherein the air passageway extends through the container and allows air to communicate between an interior of the container and the atmosphere. 5
47. The pressure equalization system of claim 43, wherein the container is substantially waterproof and substantially airtight. 10
48. The pressure equalization system of claim 43, further including a spring positioned in the air passageway, the spring structured to urge the slideable member out of the air passageway. 15
49. The pressure equalization system of claim 43, further including a sealing member coupled to the slideable member, the sealing member structured to seal the air passageway. 20
50. The pressure equalization system of claim 43, further including a stop coupled to the slideable member, the stop structured to limit a movement of the slideable member in the air passageway. 25
51. A pressure equalization system for a container comprising: 30
- a latch pivotably coupled to the container, the latch having an open position and a closed position; and
 - a deflectable member positioned in a container air passageway and adjacent to the latch, the deflectable member including an aperture; 35
- wherein the latch is structured to contact the deflectable member and close the air passageway when the latch is in the closed position, and when the latch is in the open position, the air passageway is open. 40
52. The pressure equalization system of claim 51, wherein the latch includes a tip structured to close the deflectable member. 45
53. The pressure equalization system of claim 51, wherein the latch is structured to secure a top section of the container to a bottom section of the container. 50
54. The pressure equalization system of claim 51, wherein the air passageway extends through the container and allows air to communicate between an interior of the container and the atmosphere. 55

55. The pressure equalization system of claim 51, wherein the aperture located in the deflectable member is positioned substantially along a longitudinal axis of the deflectable member and allows air to pass through the deflectable member.

56. The pressure equalization system of claim 51, wherein the deflectable member is constructed of a material selected from the group consisting of: rubber, plastic, polyurethane, a combination of any of rubber, plastic and polyurethane, and other suitable materials.

57. The pressure equalization system of claim 51, wherein the container is substantially waterproof and substantially airtight.

58. The pressure equalization system of claim 51, wherein the deflectable member is cylindrical and includes an aperture positioned along a longitudinal axis of the cylinder.

59. A method of equalizing atmospheric pressure between an interior of a container and a surrounding atmosphere, the method comprising the steps of:

- providing a deflectable member that is positioned in an air passageway in the container, the deflectable member including an aperture;
- positioning a latch adjacent to the deflectable member so that when the latch is in a closed position, the latch closes the aperture in the deflectable member; and
- pivoting the latch away from the deflectable member so that air passes through the air passageway, thereby equalizing atmospheric pressure between an interior of a container and a surrounding atmosphere.

60. A method of equalizing atmospheric pressure between an interior of a container and a surrounding atmosphere, the method comprising the steps of:

- providing a slideable member that is positioned in an air passageway in the container;
- positioning a latch adjacent to the slideable member so that when the latch is in a closed position, the latch contacts the slideable member, and the slideable member seals the air passageway; and
- pivoting the latch away from the slideable member so that air passes through the air passageway, thereby equalizing atmospheric pressure between an interior of a container and a surrounding atmosphere.

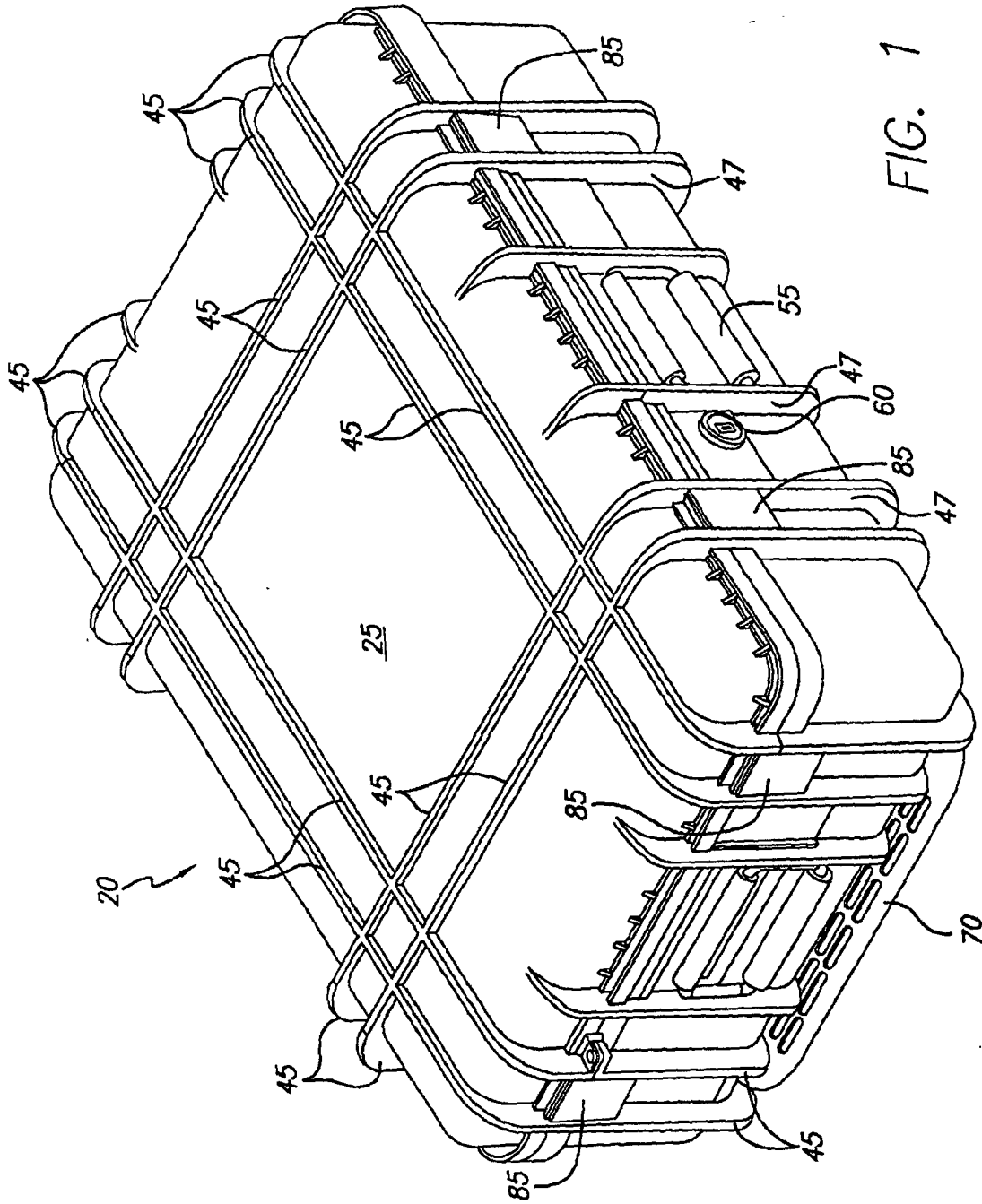

FIG. 1

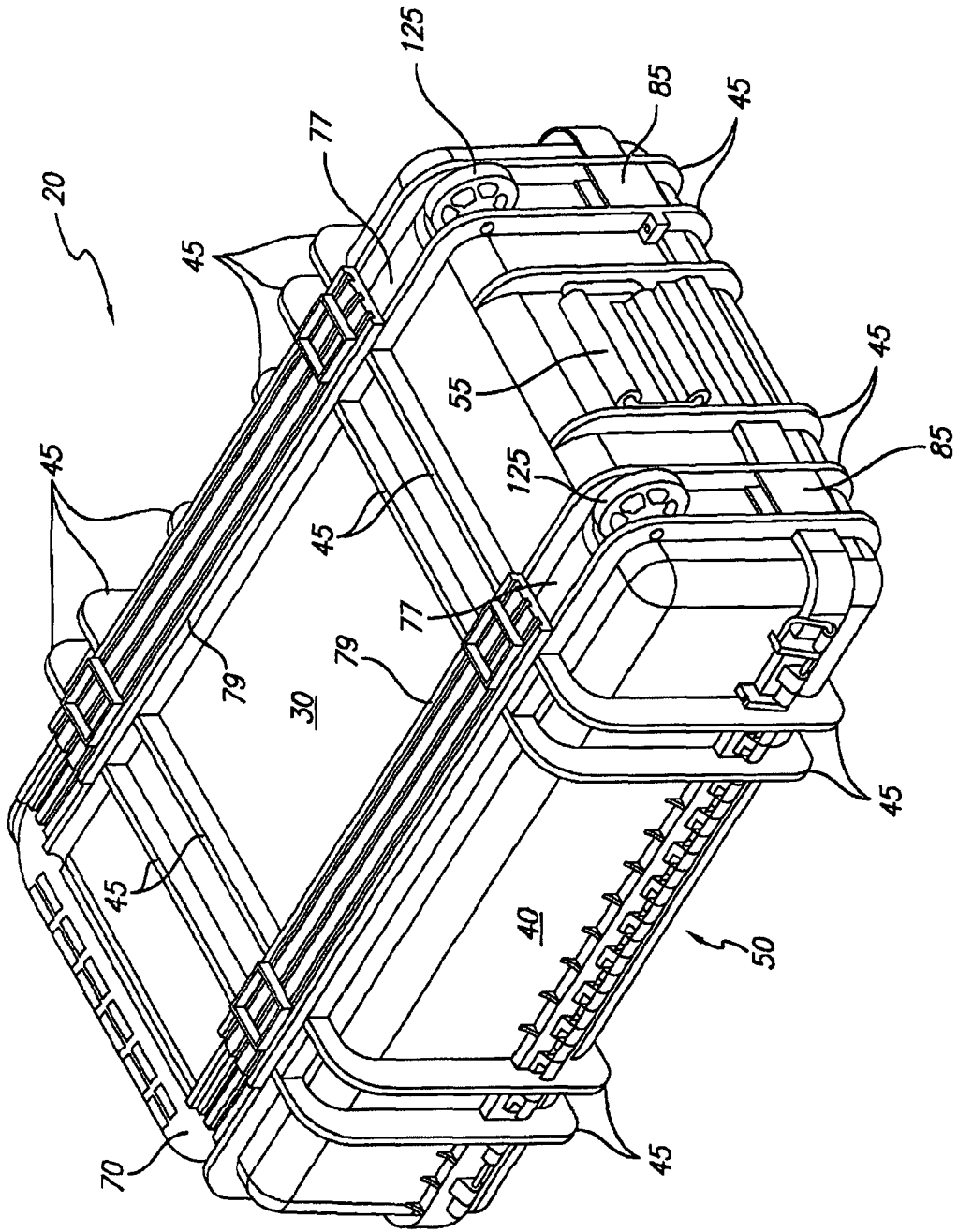
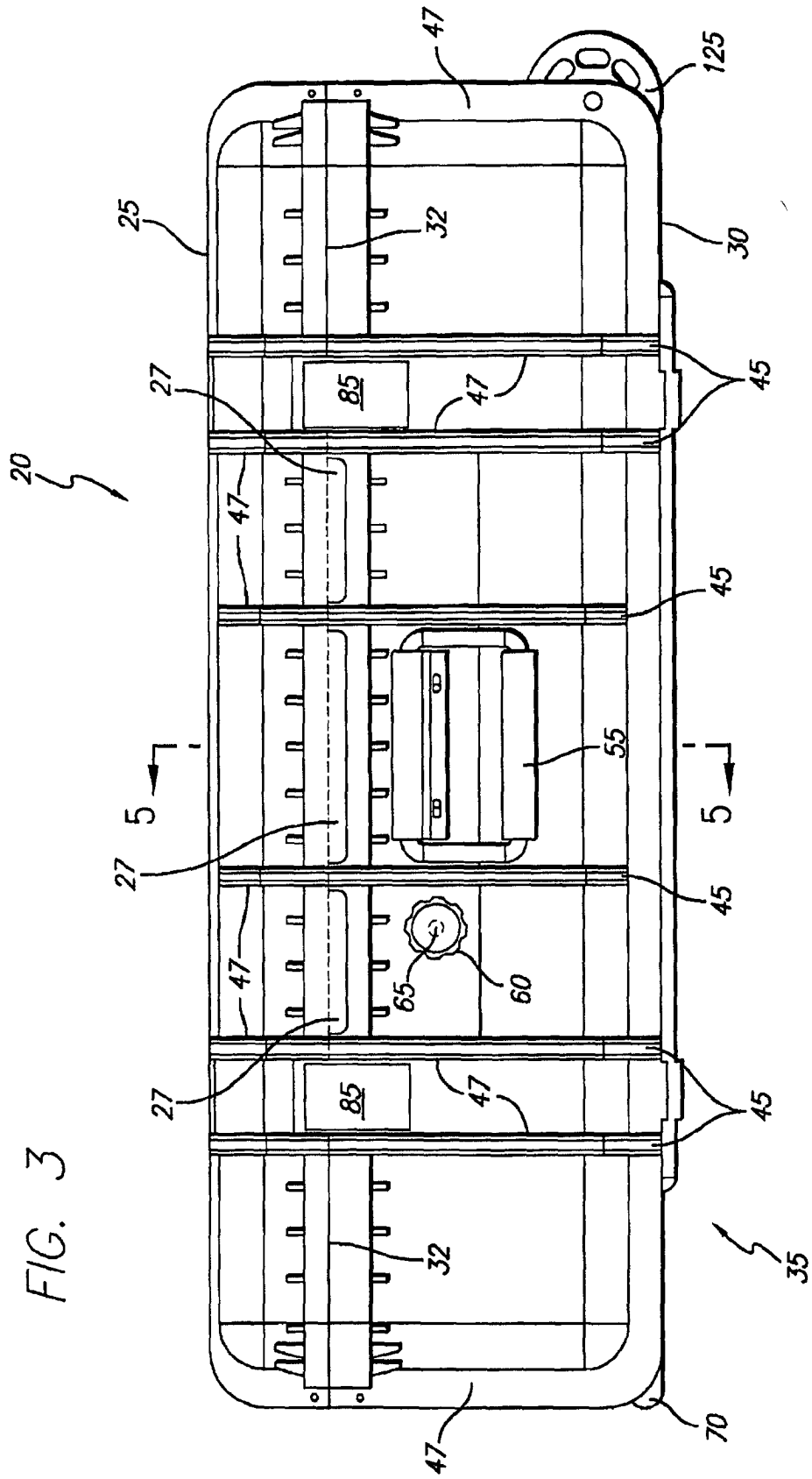

FIG. 2



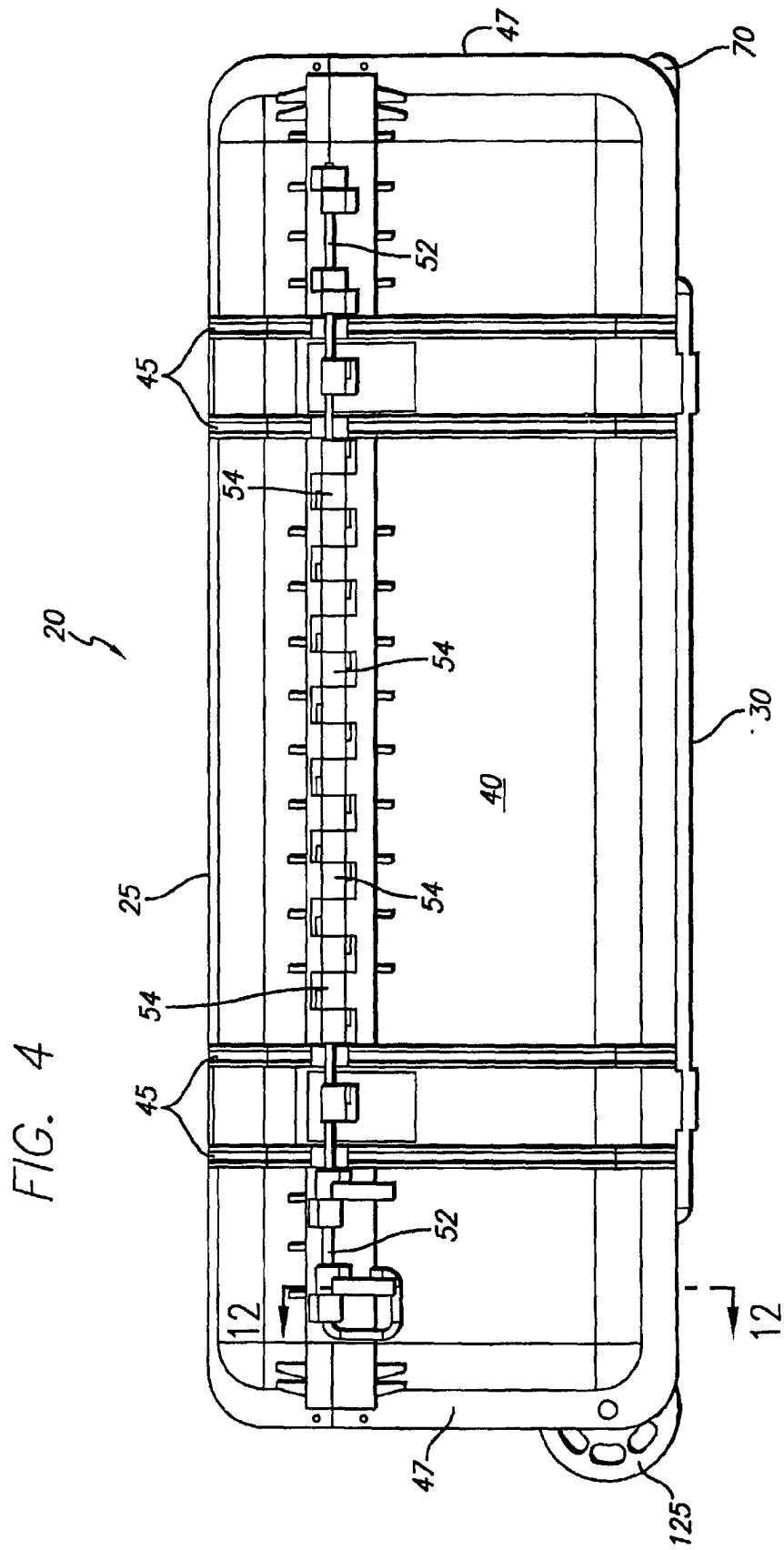
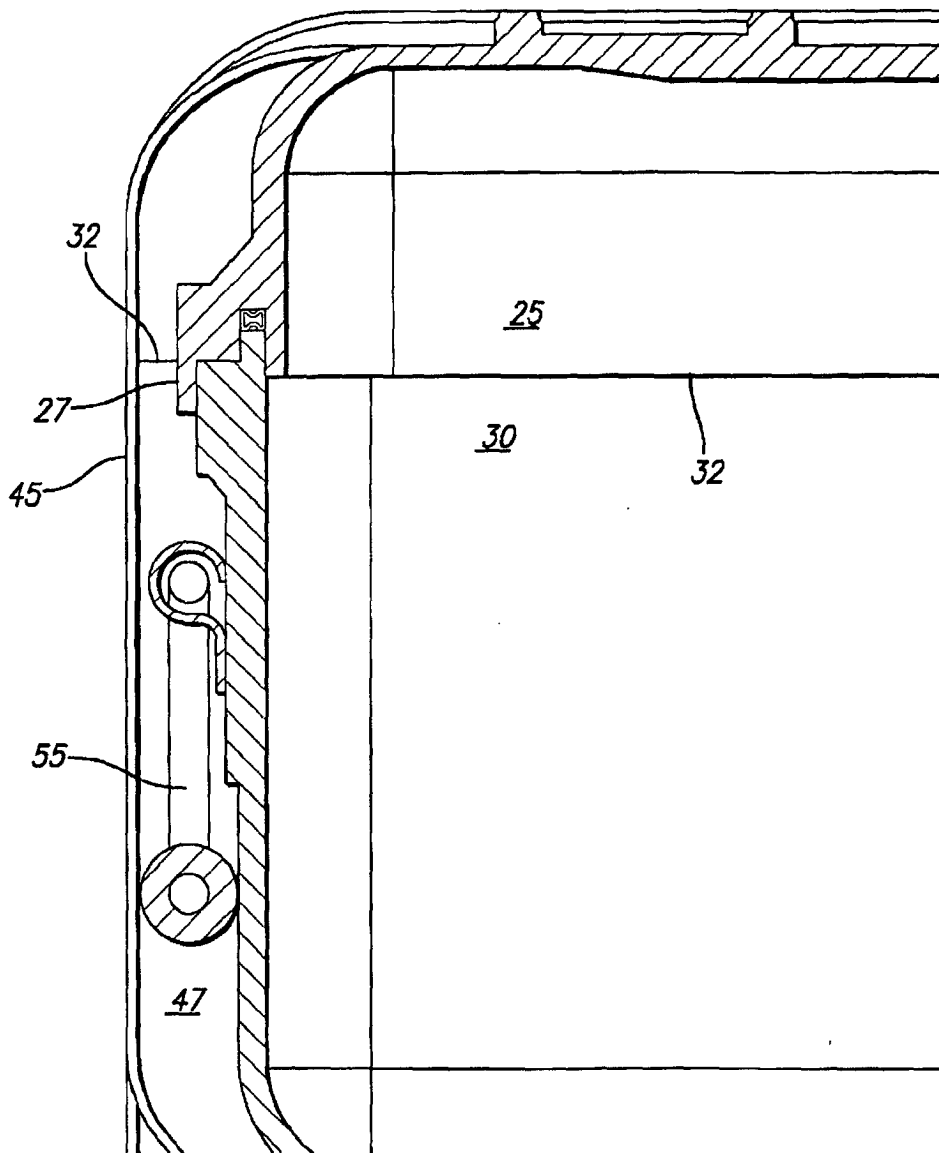

FIG. 5



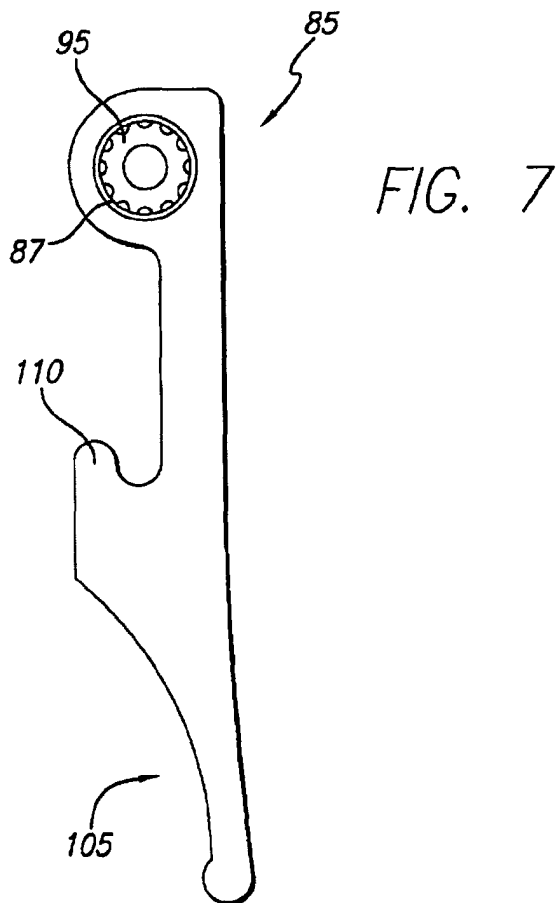
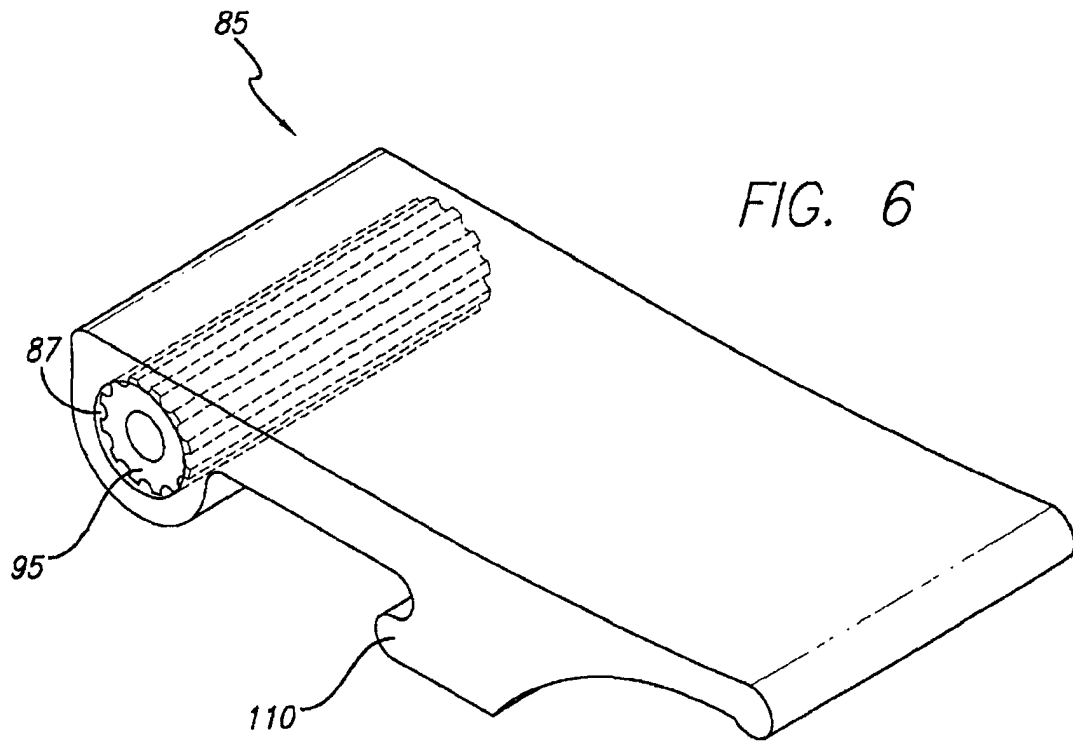

FIG. 8

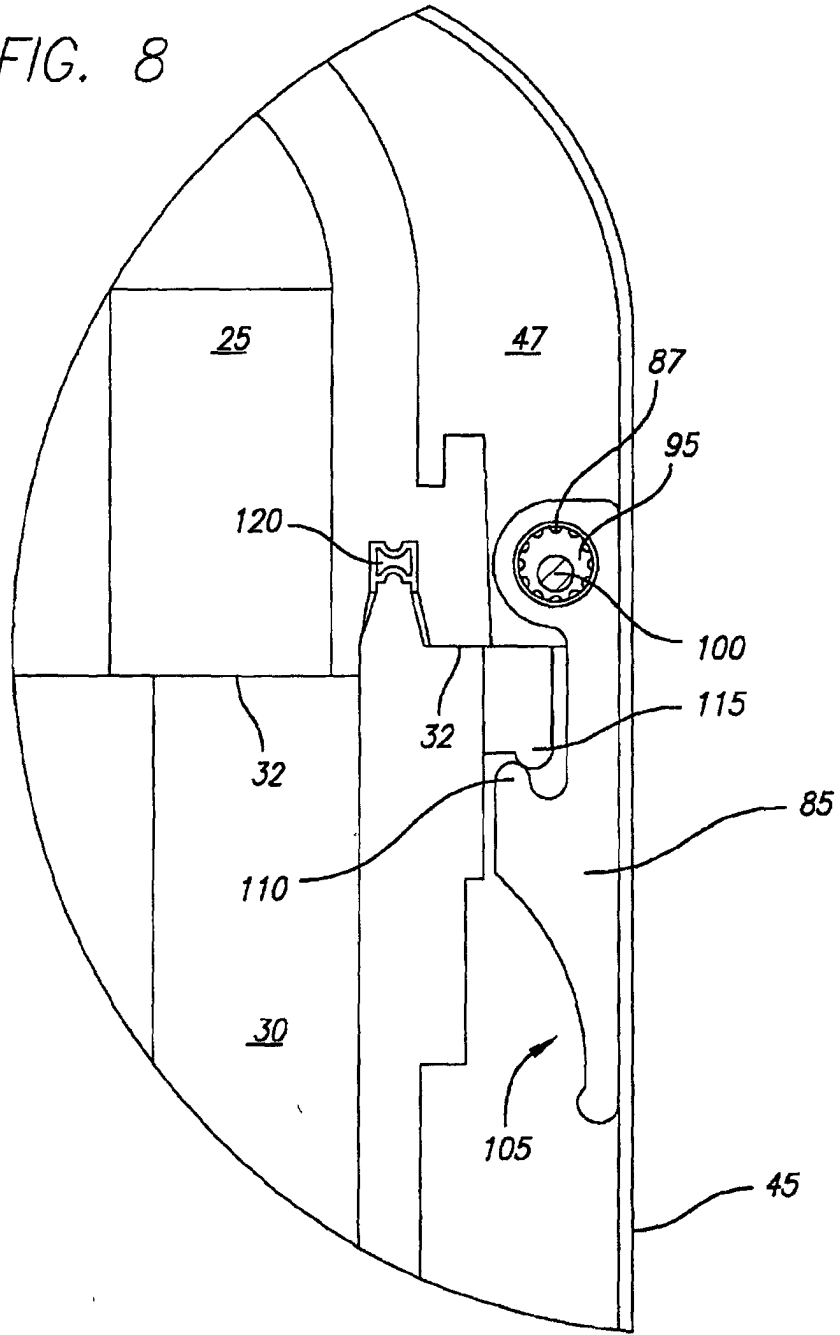

FIG. 10

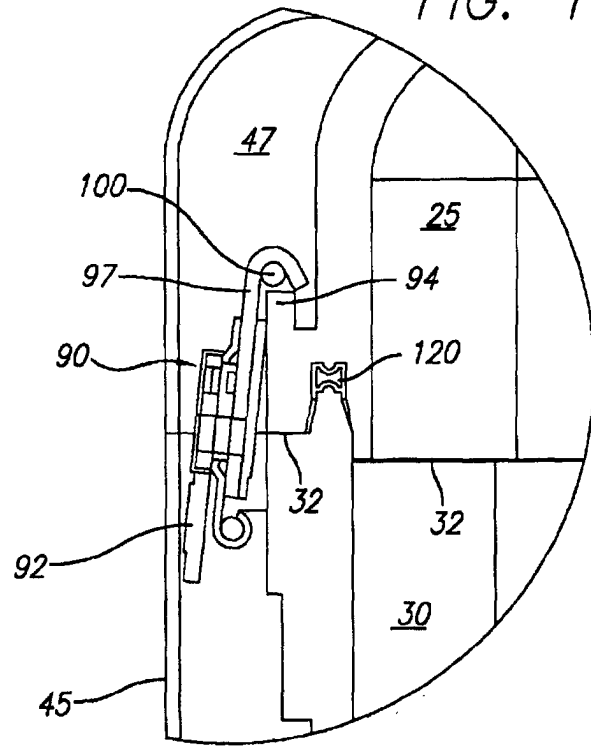
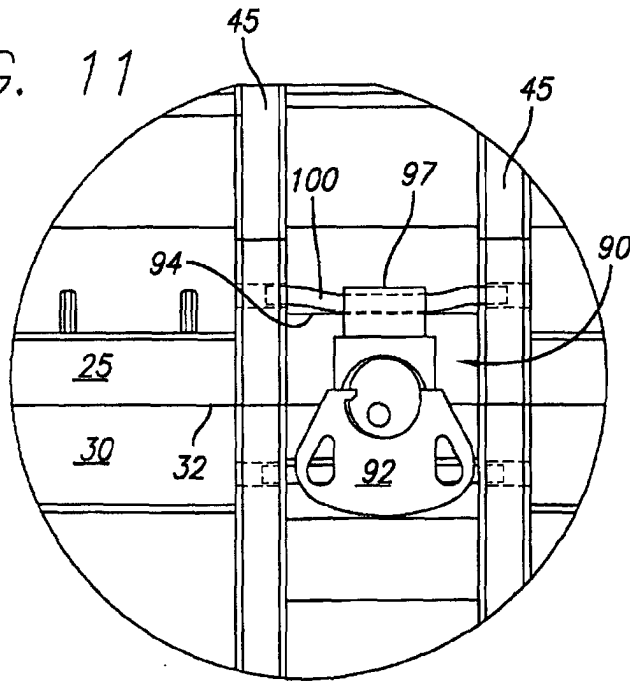

FIG. 11



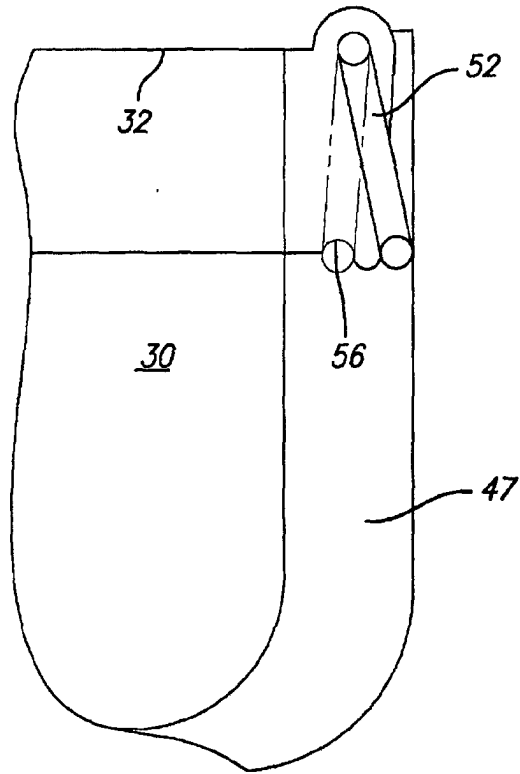

FIG. 12

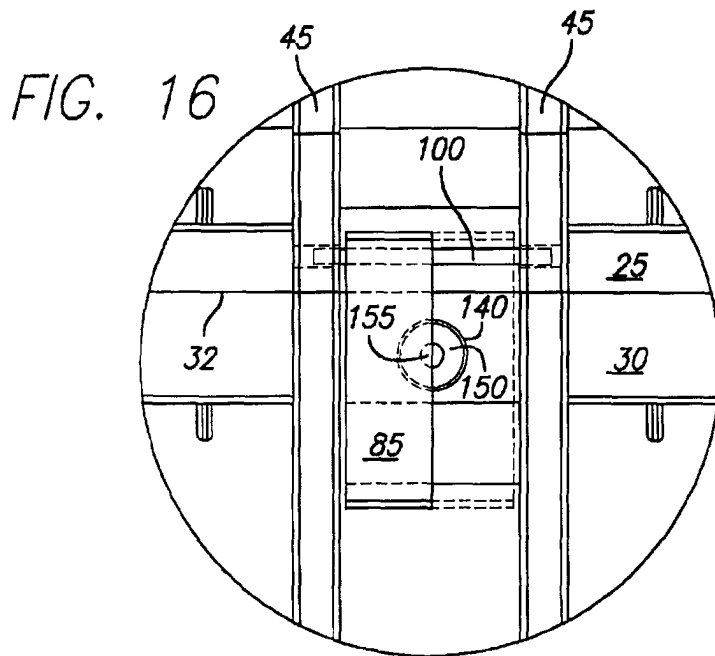

FIG. 16

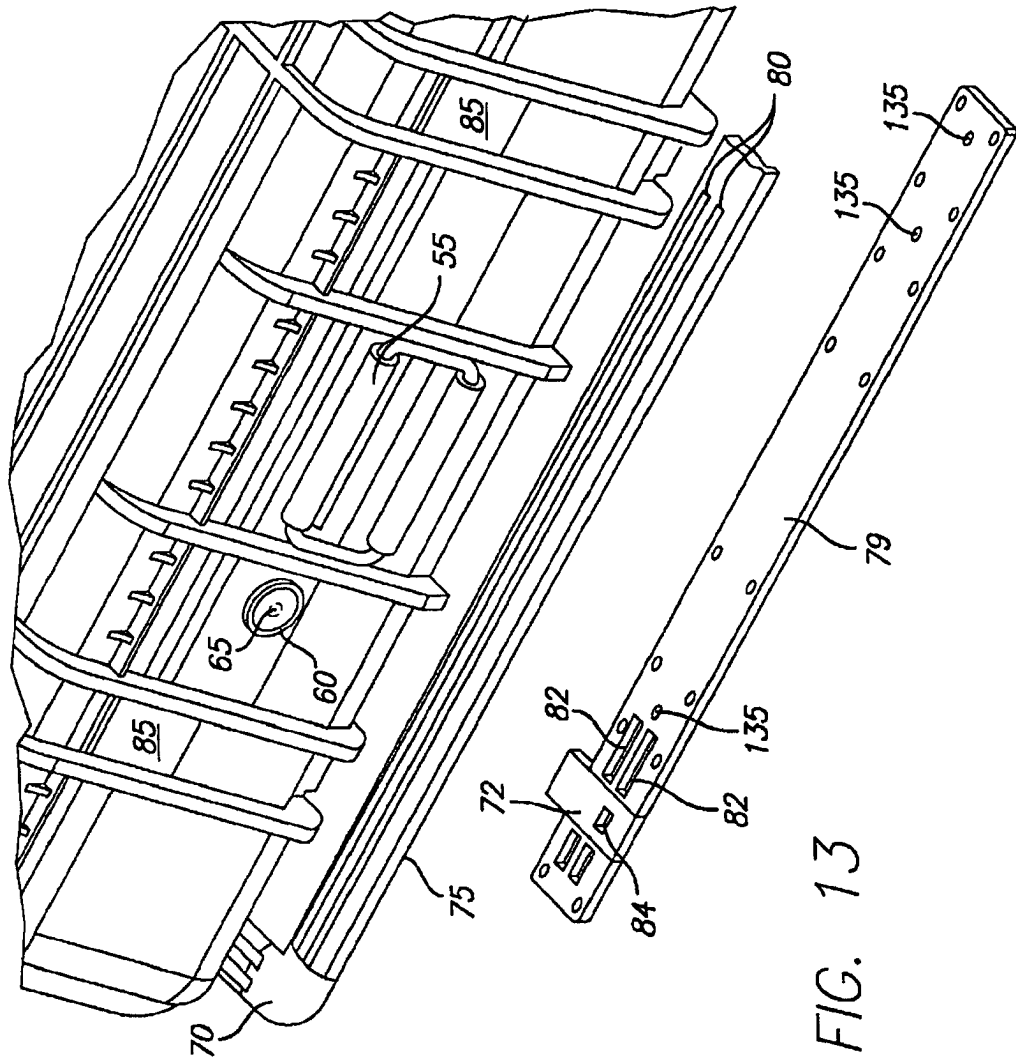

FIG. 13

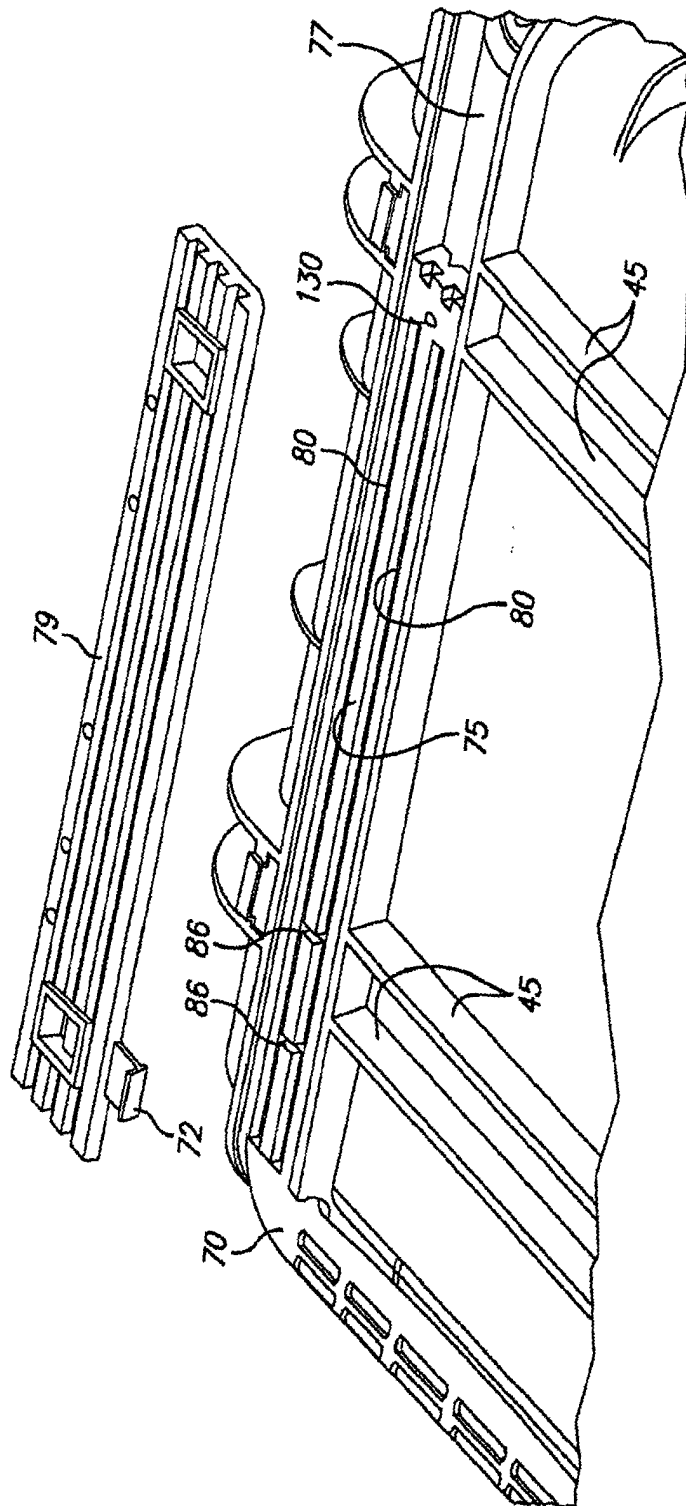

FIG. 14

FIG. 15A

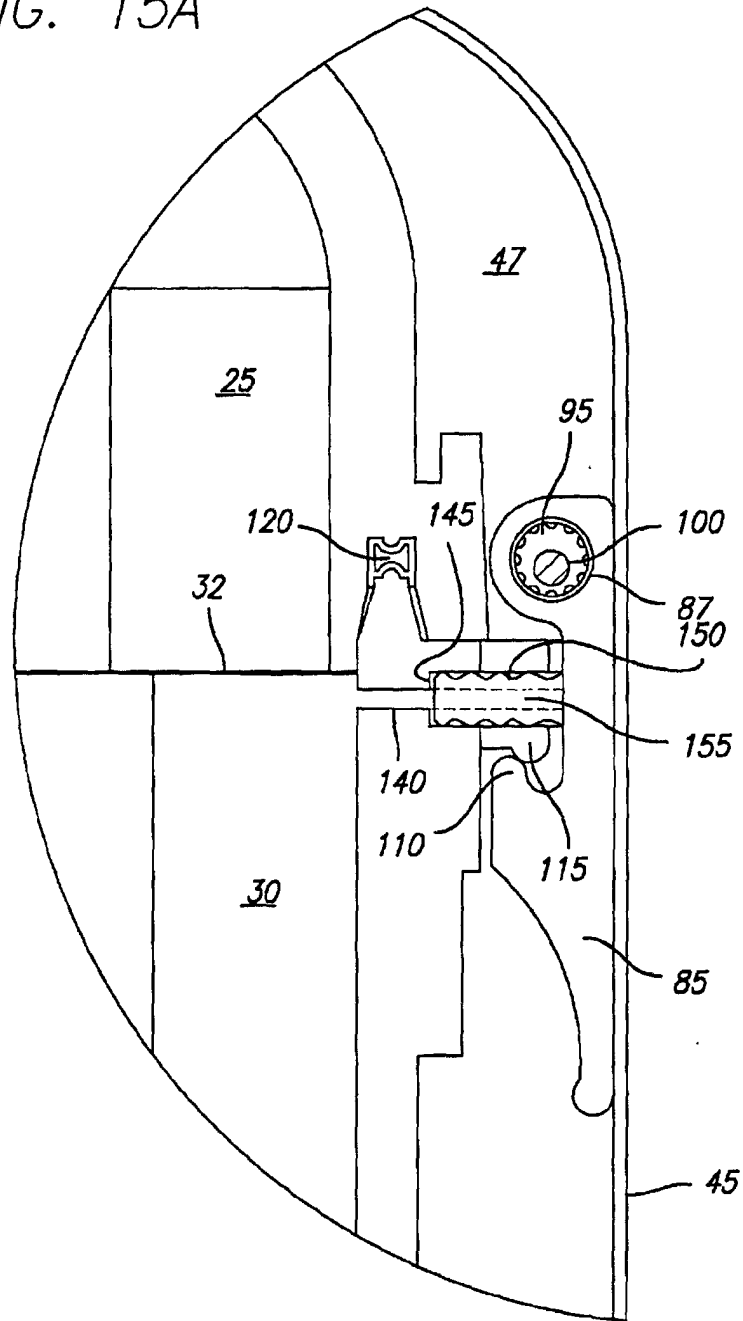

FIG. 15B

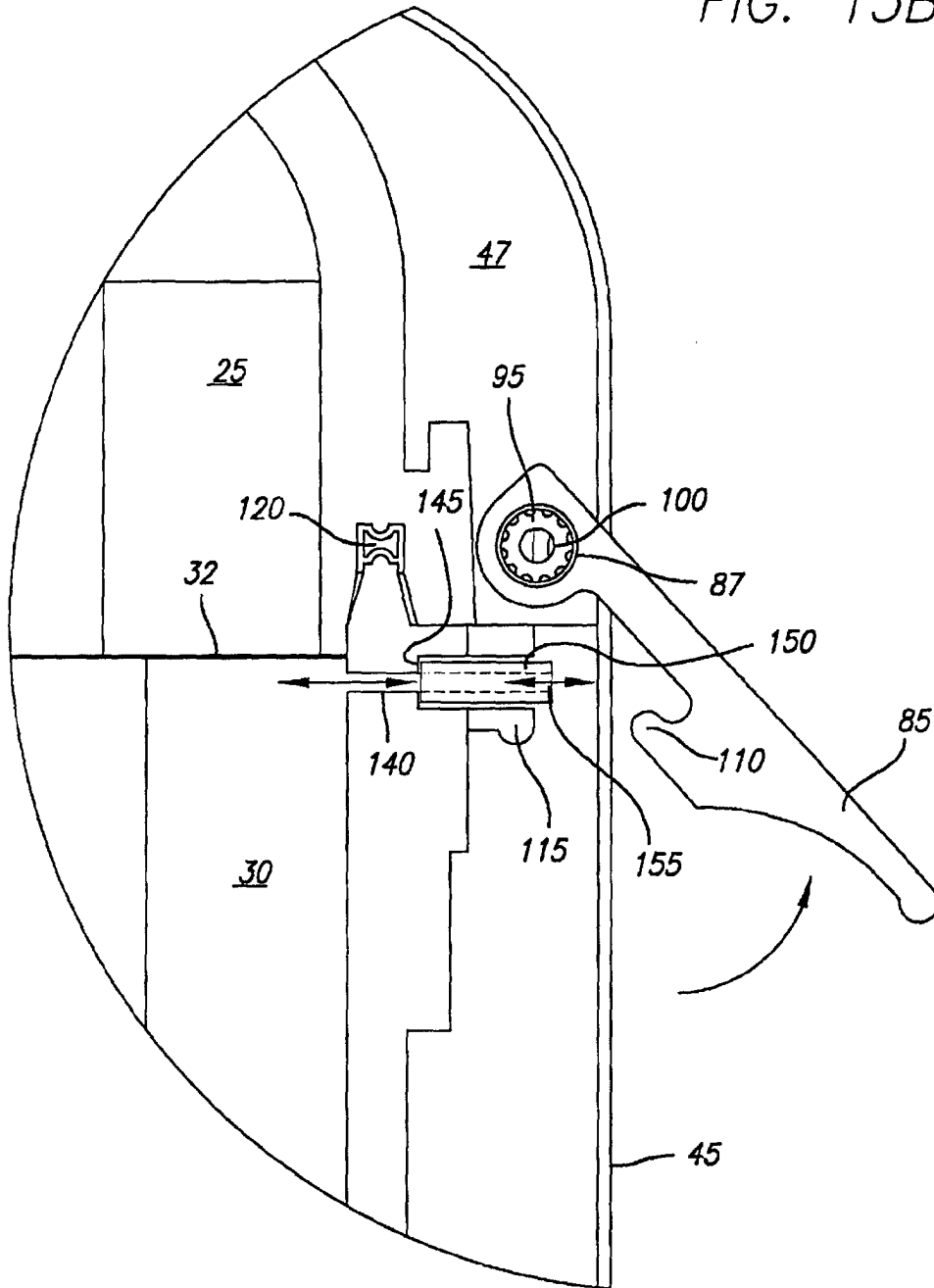

FIG. 17A

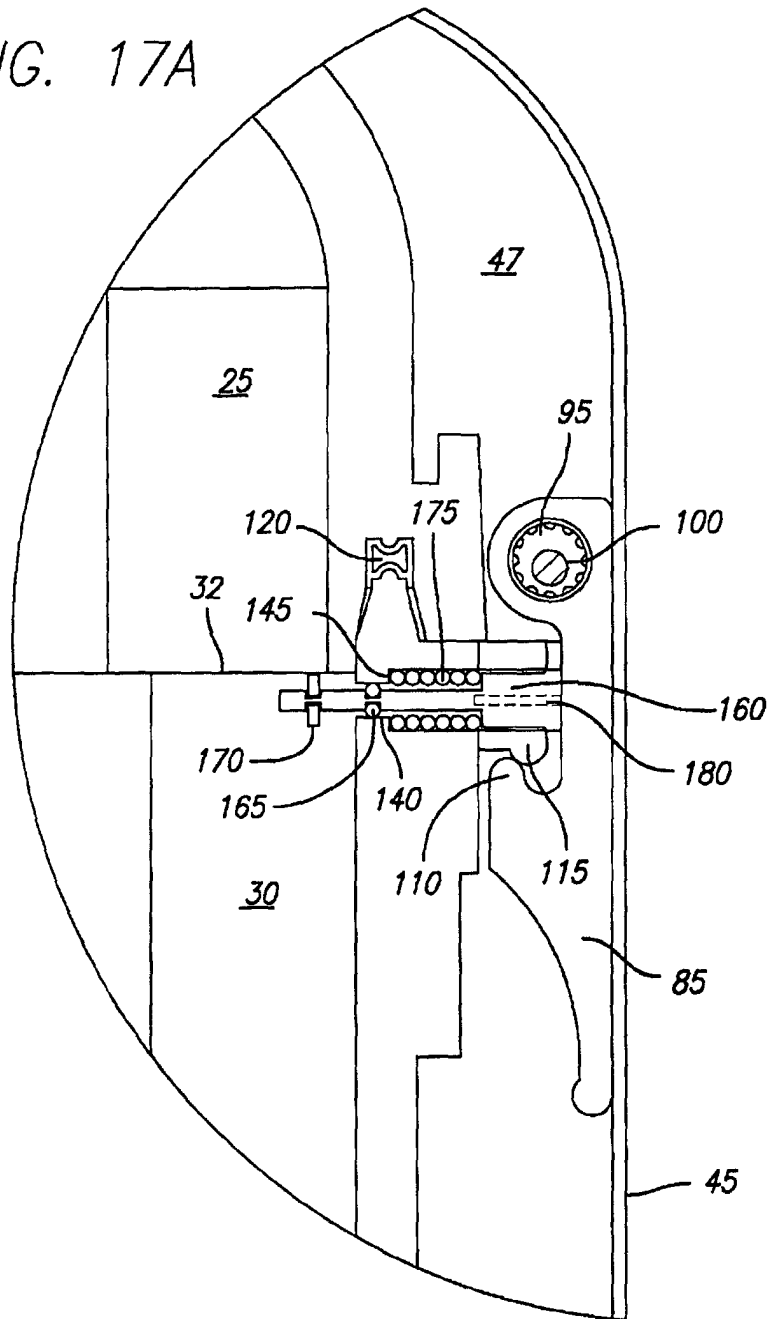

FIG. 17B

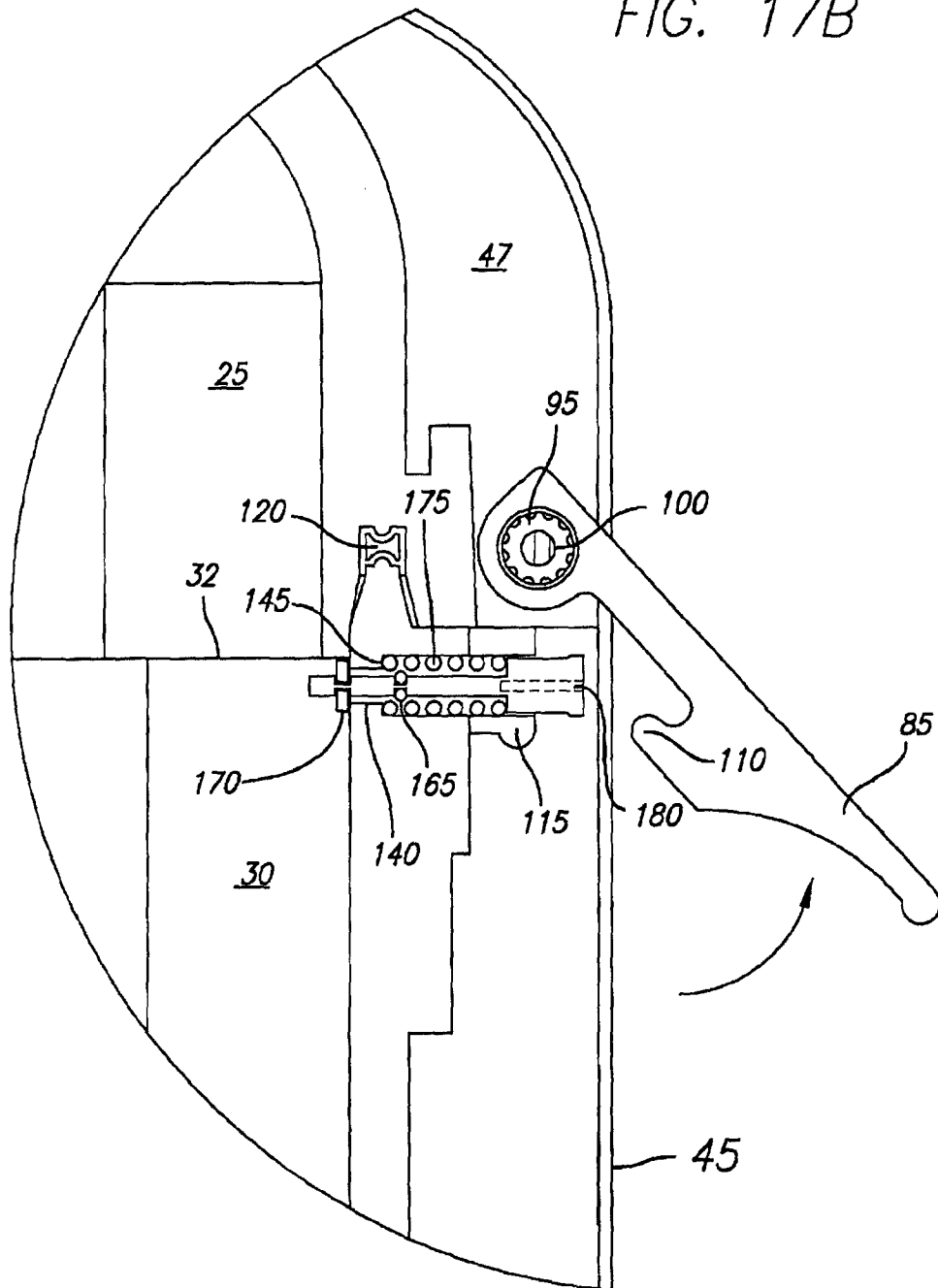

FIG. 18A

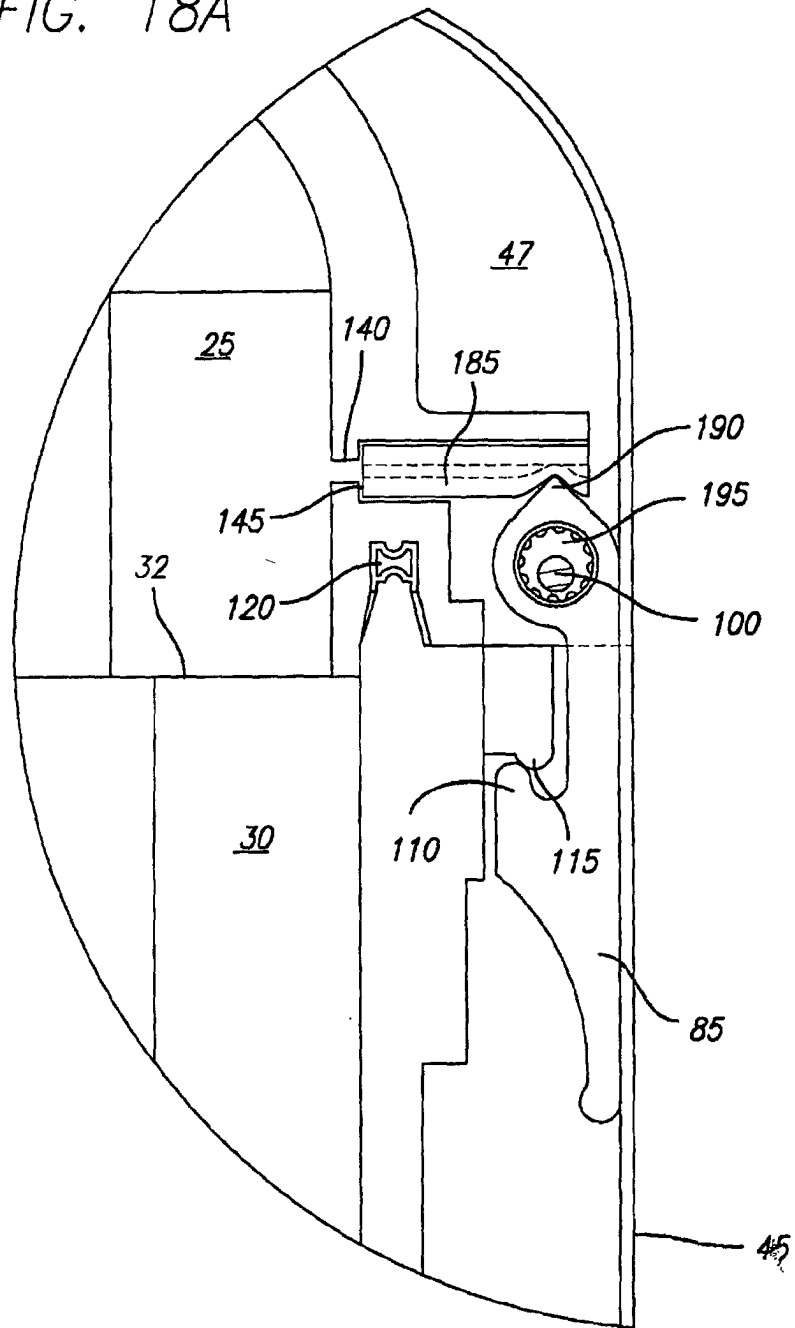

FIG. 18B

