

(19)



Europäisches Patentamt
European Patent Office
Office européen des brevets



(11)

EP 1 236 677 A1

(12)

EUROPEAN PATENT APPLICATION

(43) Date of publication:
04.09.2002 Bulletin 2002/36

(51) Int Cl.7: B67D 1/14

(21) Application number: 01830507.8

(22) Date of filing: 27.07.2001

(84) Designated Contracting States:
AT BE CH CY DE DK ES FI FR GB GR IE IT LI LU
MC NL PT SE TR
Designated Extension States:
AL LT LV MK RO SI

(72) Inventor: Castaldi, Bruno
47030 San Mauro Pascoli (Rimini) (IT)

(74) Representative: Lanzoni, Luciano
c/o BUGNION S.p.A.
Via Cairoli, 107
47900 Rimini (Forli) (IT)

(30) Priority: 28.02.2001 EP 01830138

(71) Applicant: CELLI S.p.A.
47852 Coriano (Rimini) (IT)

(54) A device for the protected adjustment of the outflow of fluids in systems for dispensing drinks

(57) A device for the protected adjustment of the outflow of fluids in systems for dispensing drinks, comprising an outer end (3), accessible by the user to actuate an internal organ for operating the adjustment, the device further comprising, preferably in combination:

- at least a contour (32), obtained in correspondence with said outer end (3), able to be coupled with rapid engagement, but removably, in a corresponding complementary contour (52) provided in a tool

- (preferably a unique and specific adjusting wrench (5)), separate from the dispensing system;
- a cap (6) able to be coupled on said end (3) and movable thereon from at least a first extreme position, in which the cap (6), stably engaged on the end (3), hides and protects the contour (32) from free access from the exterior, to a second extreme position, in which said cap (6) instead allows free access to the contour (32) from the exterior.

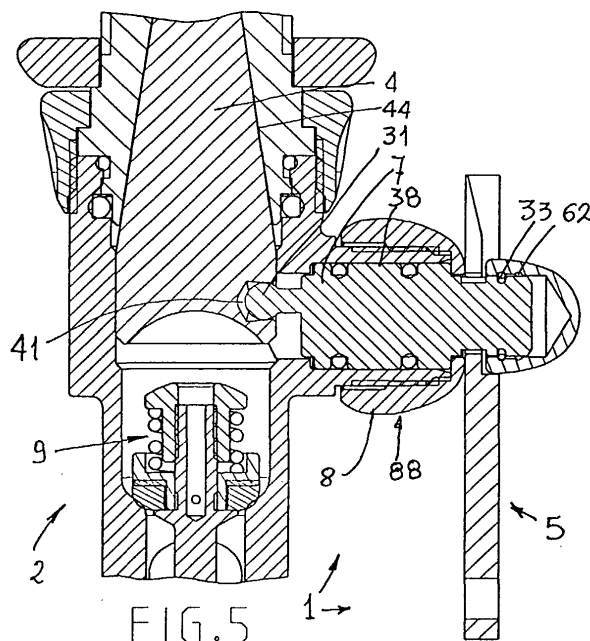

FIG. 5

EP 1 236 677 A1

Description

[0001] The present invention relates to a device for the protected adjustment of the outflow of fluids in systems for dispensing drinks, comprising an outer end, accessible by the user to actuate a device for operating the adjustment.

[0002] As is well known, drink distribution systems comprise different devices for adjusting the outflow of the drink or of the component fluids of the drink.

[0003] For carbonated drinks, such as beer, so-called compensating organs for taps dispensing carbonated drinks are, for instance, known. They are substantially conical elements, positioned along a cone frustum shaped segment of the conduit for the outflow of the beer, upstream of the shutter for closing and opening the conduit, commanded by an external knob. In this way they allow to brake and adjust the flow of beer to make it more controllable, varying the outflow port by the simple axial displacement of the compensating organ, due to the action of said command appendage.

[0004] The command appendage has a parallel axis, eccentric relative to the axis of the end, so that the axial displacement of the compensating organ can take place simply by causing the element transmitting the adjustment (and the appendage therewith) to rotate about its axis, for a sufficient arc to allow the compensating organ to make a rotary-translatory displacement, where only the translation component is functionally essential.

[0005] Thus, since it is sufficient to cause a rotation of the end, in order to vary the axial position of the compensating organ, known adjusting devices simply provide a small lever, integral with the outer end, rotating which the adjustment is performed.

[0006] Also known are devices for adjusting the outlet pressure of carbon dioxide, nitrogen or mixtures or in any case gas useful as a component or element for maintaining the equilibrium or dispensing pressure of carbonated drinks, through a pressure reducer applied to its own containment tank. In particular, the pressure is normally adjusted through a simple action by the operator on an external knob for actuating an adjustment screw engaged in the body of the pressure reducer, which effects a normally indirect adjustment of the opening or closing of the shutter of the reducer, depending on the depth of engagement of its own threaded stem.

[0007] Lastly, also known are the simple devices for adjusting the outflow of syrup and/or flat or carbonated water, normally obtained by means of simple screw adjustment elements (flow controls), applied on the so-called post-mix valves of known systems by that name.

[0008] These solutions, however, have a drawback.

[0009] The adjustment lever of the compensating organ, or the knob for adjusting carbon dioxide pressure, being external and quite visible, are too easily accessible to everyone, in particular to non specialised or unauthorised personnel, who could perform adjustments not suitable for a regular dispensing or cause accidental

displacements of the lever, with the consequent need frequently to intervene on the adjustments to bring them back to correct parameters.

[0010] The adjustment controls of post-mix valves are also too easily accessible and open to manipulation by means of simple screwdrivers.

[0011] The aim of the present invention is to overcome the aforementioned drawback, making available a device that allows adjustments to be performed only by specialised or in any case authorised personnel, necessarily provided with special adjustment tools or wrenches.

[0012] Further aims and advantages, which will become more readily apparent from the description that follows, are achieved, in accordance with the present invention, by a protected adjustment device according to the content of the claims.

[0013] The invention is described in greater detail hereafter with the aid of the drawings, which show an embodiment provided purely by way of non limiting example:

- Figure 1 shows a lateral view of essential parts of the subject device, in which the internal operating element is of the type applicable to compensating organs of taps for dispensing beer or carbonated drinks;
- Figures 2 and 3 show a particular wrench, comprised in the subject device, respectively in a front view and in a section according to the section line III-III;
- Figures 4 and 5 show a top view of a longitudinal section of the tap provided with the subject device, illustrated in two characteristic views in which it is respectively in a first extreme position of maximum protection (with the wrench positioned ready for an intervention) and in its second position of free access to the adjustment (with the wrench executing its intervention);
- Figure 6 shows a perspective view of the key of Figures 2 and 3;
- Figure 7 shows a lateral, partially sectioned view of the subject device applied to a pressure reducer for tanks containing carbon dioxide or nitrogen or any gas useful for drinks, in a first embodiment thereof;
- Figure 8 shows a partially sectioned lateral view of the subject device applied to a pressure reducer for tanks containing carbon dioxide or nitrogen or any gas useful for drinks applied to its second embodiment.

[0014] With reference to Figures 1, 4 and 5, the protected adjustment device (1) applied to compensating organs (4) in taps (2) for dispensing beer is described first. The compensating organs are substantially conical elements, positioned along a cone frustum shaped segment (44) of the conduit for the outflow of beer, upstream of the shutter (9) for closing and opening the conduit,

commanded by an external knob. In this way they allow to brake and adjust the flow of beer to make it more controllable, varying the outflow port with the simple axial displacement of the compensating organ (4). This displacement is due, in known devices, to the action of a command appendage (31), obtained at an extreme inner side of an element (7) for transmitting the adjustment and engaged in a seat (41) obtained in the compensating organ (4). Normally the element (7) is inserted, in sealing fashion, in its own seat (38) which extends laterally to the body of the tap (2) and is locked here by an external ring nut (8).

[0015] The command appendage has an axis that is parallel, but eccentric relative to the axis of the outer end (3) of the element (7), so that the axial displacement of the compensating organ (4) can take place simply by causing the element (7) (and the appendage therewith) about its axis, for a sufficient arc to allow the compensating organ to make a rotary-translatory displacement, where only the translation component is functionally essential.

[0016] This stated, the outer end (3) of the element (7), which in this case coincides with the outer end (1) of the subject device, has a special contour (32), able to couple, rapidly but removably, in a corresponding complementary contour (52) obtained in a tool (preferably constructed specifically for the purpose), which serves as unique and specific wrench (5) for adjusting the compensating organ (4), separate from the tap (2).

[0017] In this way, the necessary adjustments on the compensating organ of each tap can be performed solely and exclusively by specialised, or in any case authorised personnel, who has said wrench (5), without which it is not easy, without risks of damaging the whole tap, to access the adjustment.

[0018] In order fully to achieve the aforesaid aim, the presence is in any case preferable, if not essential, of a protecting and armour-plating cap (6), able to be coupled on said end (3) and movable thereon from at least a first extreme position, in which the cap (6), thrust fully on the end (3) and stably engaged thereon, hides and protects the contour (32) from free excess from the exterior, to a second extreme position, in which the cap (6), which is at least partially extracted from the end (3) instead allows free access from the exterior to the contour (32).

[0019] If the cap (6) is present, it would no longer be strictly necessary to provide a specific wrench (5). Therefore the regulating device could comprise, in combination with said cap (6), a contour (32) simply provided to be coupled with a corresponding complementary contour (52) of a common tool for the normal adjustment of the compensating organ (4).

[0020] In any case, although the use of multiple wrenches or tools is not excluded in principle, the subject device advantageously provides for the use of a same unique and specific wrench so shaped as to be also used to allow at least the partial uncoupling of the

cap (6) from the end (3) in order rapidly to move it from the first to the second extreme position.

[0021] More specifically, the outer end (3) and the cap (6) comprise, the former, an elastic annular element (33) (in this case open, to provide it with greater flexing ability) and the latter at least a corresponding seat (61) for the forced housing of the annular element (33) (or vice versa), for the stable and removable coupling of the cap (6) on the outer end (3), at least in its first extreme position.

[0022] It is in any case advantageous to provide for two seats (61, 62), respectively able to allow a stable, but removable positioning, of the cap (6), both in the first and in the second extreme position which it can assume on the outer end (3), in such a way as to move the cap (6) only to the extent necessary, still maintaining it comfortably secured to the end (3).

[0023] The preferred contour (32), in the example shown, is the one determined simply by two opposite millings (34, 35) obtained in the body of the end (3), cylindrical shaped in this embodiment, whilst the cap (6), in its first extreme position, covers almost totally the outer end (3), frontally facing, with its free end (63), an underlying external abutment element (88) in this case coinciding with the external ring nut (8) for locking the end (3) itself.

[0024] Correspondingly, the wrench (5) has two tines (51) provided with their own wedge shaped ends (53), to be easily introduced between the cap (6) and the external ring nut (8), when the cap (6) needs to be detached from its first extreme position, uncovering the contour (32). The tines, furthermore, are internally distanced in accordance with the distance that separates said millings (34, 35), so that they become engaged between said tines (51), when it is necessary to adjust the compensating organ (4).

[0025] Advantageously, the tines (51) also present corresponding upper extensions (54), distanced according to the diameter of the cylindrical body of the end, so that the wrench (5) can rapidly detach the cap (6), once the extensions (54) are even partially introduced between cap (6) and external ring nut (8), simply by rotating the wrench (5). A further advantage also stems from the fact that the thickness of the wrench (5) corresponds to the distance between the first and the second extreme position that the cap (6) can assume. If, lastly, the wrench is made of plastic material (as in the case at hand) it may comprise peripheral stiffening ribs (10).

[0026] In the example illustrated above, the subject device (1) was described applied to compensating organs (4) of taps for dispensing beer, and in particular applied directly onto the outer end (3), accessible by the user, for controlling the adjustment.

[0027] However, it is identically applicable also, for instance, to shutters of pressure reducers (11) in tanks containing additional gasses for drinks, as shown in Figures 7 and 8. In this case, it is obtained in correspondence with the outer head (13) of the screw (12) for ad-

justing the opening or closing of the shutter of the pressure reducer (11), according to the depth of engagement of its own threaded stem (14). In this case it is preferable for the device to comprise an element (20) for protecting a portion of the threaded stem (14) of the adjusting screw (12), able to be integrally fastened axially to the stem.

[0028] It is advantageous for the protecting element (20) to have axial development at least equal to the maximum excursion of the adjusting screw (12), so that the thread of said adjusting screw (12) is never exposed exteriorly and hence it is particularly well protected.

[0029] The protecting element (20) may be positioned externally and in sliding fashion to the engagement head (15) of the stem (14) of the adjusting screw (12), as in Figure 7, or internally and in sliding fashion to the engagement head (15) of the stem (14) of the adjusting screw, where in this case a seat (21) is provided for housing the protection element (20). Its stable positioning may for instance be obtained by means of a Seeger ring (22) which makes it axially constrained to the screw (12), in correspondence with a corresponding annular seat (16).

[0030] In the application of Figures 7 and 8, lastly, one can observe that the external abutment element (88), underlying the cap (6), in this case coincides with the protecting element (20) of the threaded stem (14).

[0031] Obviously, a similar device can also be applied to so-called post-mix valves.

[0032] The invention thus conceived can be subject to numerous modifications and variations, without thereby departing from the scope of the inventive concept. Moreover, all components can be replaced by technically equivalent elements.

[0033] In practice all the materials employed, as well as the dimensions, can be any, depending on requirements.

Claims

1. A device for the protected adjustment of the outflow of fluids in systems for dispensing drinks, comprising an outer end (3), accessible by the user to actuate an internal organ for operating the adjustment, **characterised in that** said outer end (3) presents at least a contour (32) able to couple rapidly but removably in a corresponding complementary contour (52) obtained in a tool that serves as unique and specific adjusting wrench (5) separate from the dispensing system.
2. A protected adjustment device as claimed in claim 1, **characterised in that** it further comprises a cap (6) able to be coupled on said end (3) and movable thereon from at least a first extreme position, in which the cap (6), stably engaged on the end (3), hides and protects the contour (32) from free access from the exterior, to a second extreme position, in which said cap (6) instead allows free access to the contour (32) from the exterior.
3. A device for the protected adjustment of the outflow of fluids in systems for dispensing drinks, comprising an outer end (3), accessible by the user to actuate an internal organ for operating the adjustment, **characterised in that** it comprises, in combination:
 - at least a contour (32), obtained in correspondence with said outer end (3), able to be coupled with rapid engagement, but removably, in a corresponding complementary contour (52) provided in an adjusting tool, separate from the dispensing system;
 - a cap (6) able to be coupled on said end (3) and movable thereon from at least a first extreme position, in which the cap (6), stably engaged on the end (3), hides and protects the contour (32) from free access from the exterior, to a second extreme position, in which said cap (6) instead allows free access to the contour (32) from the exterior.
4. A protected adjustment device as claimed in claim 2, **characterised in that** the unique and specific adjusting wrench (5) is so shaped as to be used also to allow the cap (6) to pass easily and rapidly from the first to the second extreme position.
5. A protected adjustment device as claimed in claim 3, **characterised in that** the adjusting tool is a unique and specific wrench (5), so shaped as to be usable also to allow the cap (6) to pass easily and rapidly from the first to the second extreme position.
6. A protected adjustment device as claimed in any of the claims from 2 to 5, **characterised in that** the outer end (3) and the cap (6) comprise, the former, an elastic annular element (33) and the latter at least a corresponding seat (61) for the forced housing of the annular element (33), for the stable and removable coupling of the cap (6) on the outer end (3), at least in its first extreme position.
7. A protected adjustment device as claimed in claim 6, **characterised in that** the seats (61, 62) are two in number, respectively able to allow a stable, but removable, positioning of the cap (6), both in the first, and in the second extreme position which the cap (6) can assume on the outer end (3).
8. A protected adjustment device as claimed in claim 4 or 5 or 7, **characterised in that** the contour (32) is constituted by two opposite millings (34, 35) obtained in the body of the end (3) at the same height, whilst the cap (6), in its first extreme position, covers

almost completely the outer end (3), frontally facing, with its free end (63), an underlying external abutment element (88), said unique and specific wrench (5) having two tines (51) with their ends (53) wedge shaped, in order to be easily introduced between the cap (6) and the external abutment element (88), when it is necessary to force the detachment of the cap (6) from its first extreme position, uncovering the contour (32), said tines also being internally distanced in accordance with the distance between said millings (34, 35), in such a way that they engage between said tines (51), when it is necessary to adjust the compensating organ (4).

9. A protected adjustment device as claimed in claim 8, **characterised in that** said tines (51) have corresponding upper extensions (54), distanced according to the diameter of the body of the end (3), in such a way that the unique wrench (5) can rapidly detach the cap (6), once the extensions (54) are even partially introduced between cap (6) and external abutment element (88), simply by rotating the wrench (5).

10. A protected adjustment device as claimed in claim 8 or 9, **characterised in that** the thickness of the wrench (5) corresponds to the distance between the first and second extreme position that the cap (6) can assume.

11. A protected adjustment device as claimed in any of the previous claims, applied to organs (4) for compensating beer dispensing taps, of the type in which the control of the axial displacement of the compensating organ (4) is caused by the actuating of an appendage (31) engaged in a seat (41) obtained in the compensating organ (4), **characterised in that** it is applied directly onto the outer end (3), accessible by the user, for commanding the adjustment.

12. A protected adjustment device as claimed in claim 8 or 9 or 10, applied to organs (4) for compensating beer dispensing taps, of the type in which the control of the axial displacement of the compensating organ (4) is caused by the actuating of an appendage (31) engaged in a seat (41) obtained in the compensating organ (4), **characterised in that** it is applied directly onto the outer end (3), accessible by the user, for commanding the adjustment, whilst said underlying external abutment organ (88) is constituted by the external ring nut (8) for locking the end (3).

13. A protected adjustment device as claimed in any of the previous claims from 1 to 10, applied to shutters of pressure reducers (11) in tanks containing additional gasses for drinks, **characterised in that** it is obtained in correspondence with the outer head

(13) of the screw (12) for adjusting the opening or closing of the shutter of the pressure reducer (11), according to the depth of engagement of its own threaded stem (14).

14. A protected adjustment device as claimed in claim 13, **characterised in that** it comprises an element (20) for protecting a portion of the threaded stem (14) of the adjusting screw (12), able to be integrally fastened axially to the stem and with axial development at least equal to the maximum excursion of the adjusting screw (12), so that the thread of said adjusting screw (12) is never exposed exteriorly.

15. A protected adjustment device as claimed in claim 14, **characterised in that** the protecting element (20) is positioned externally and in sliding fashion to the engagement head (15) of the stem (14) of the adjusting screw (12).

16. A protected adjustment device as claimed in claim 14, **characterised in that** the protecting element (20) is positioned internally and in sliding fashion to the engagement head (15) of the stem (14) of the adjusting screw (12), where a seat (21) is provided for housing the protecting element (20).

17. A protected adjustment device as claimed in claim 8 or 9 or 10, applied to shutters of pressure reducers (11) in tanks containing additional gasses for drinks, **characterised in that** said outer end (3) is obtained directly in correspondence with the outer head of the screw (12) for adjusting the opening or closing of the shutter of the reducer (11), according to the depth of engagement of its threaded stem (14), there being also an element (20) for protecting a portion of the threaded stem (14) of the adjusting screw (12), able to be integrally fastened axially to the stem and with axial development at least equal to the maximum excursion of the adjusting screw (12), in such a way that the thread of said adjusting screw (12) is never exposed exteriorly, said underlying external abutment element (88) coinciding with the element (20) for protecting the threaded stem (14).

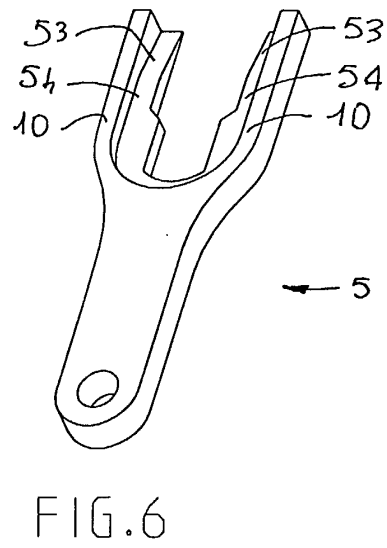
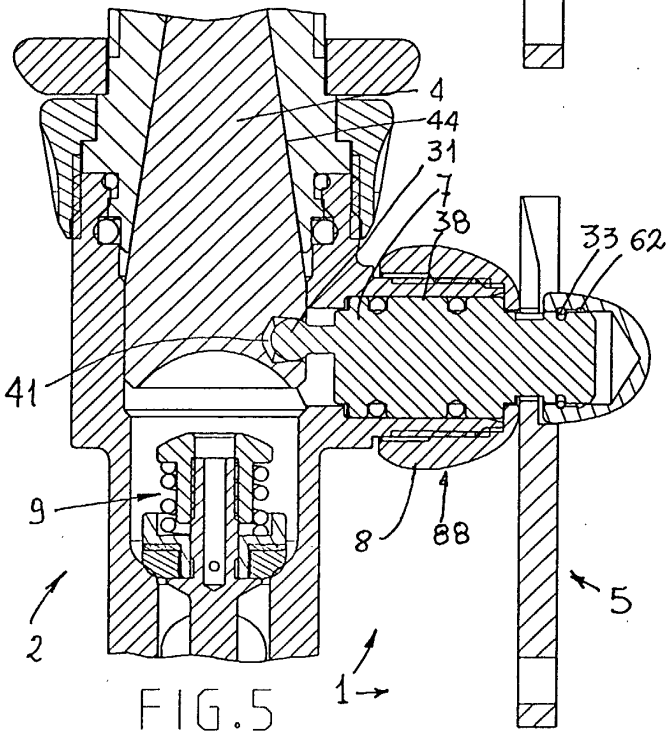
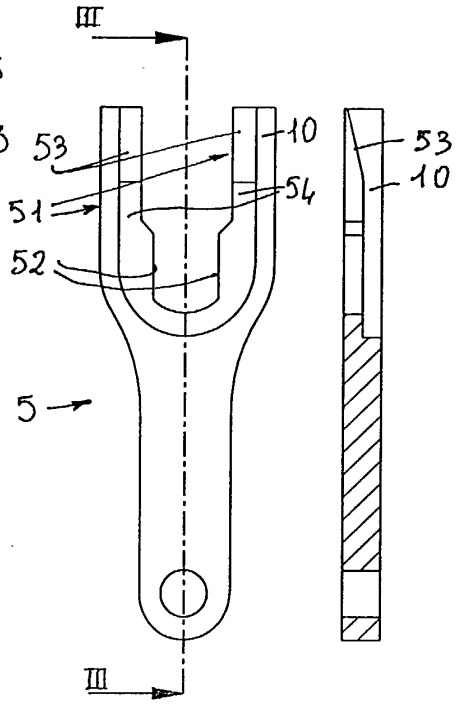
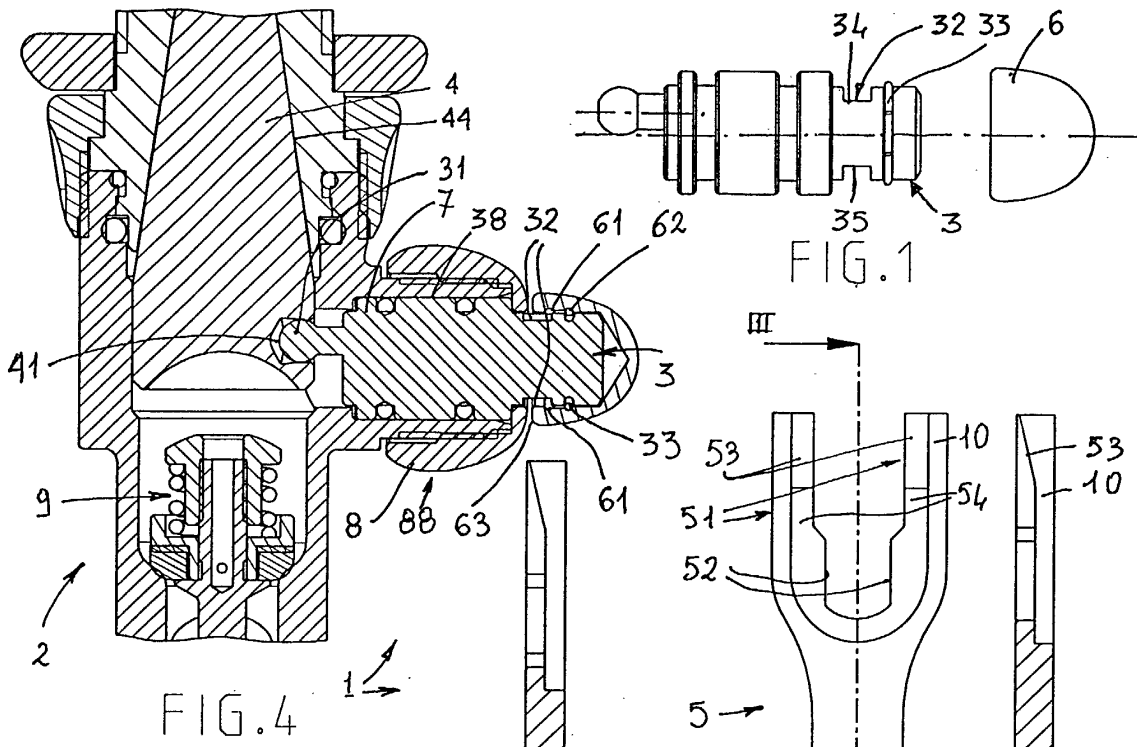

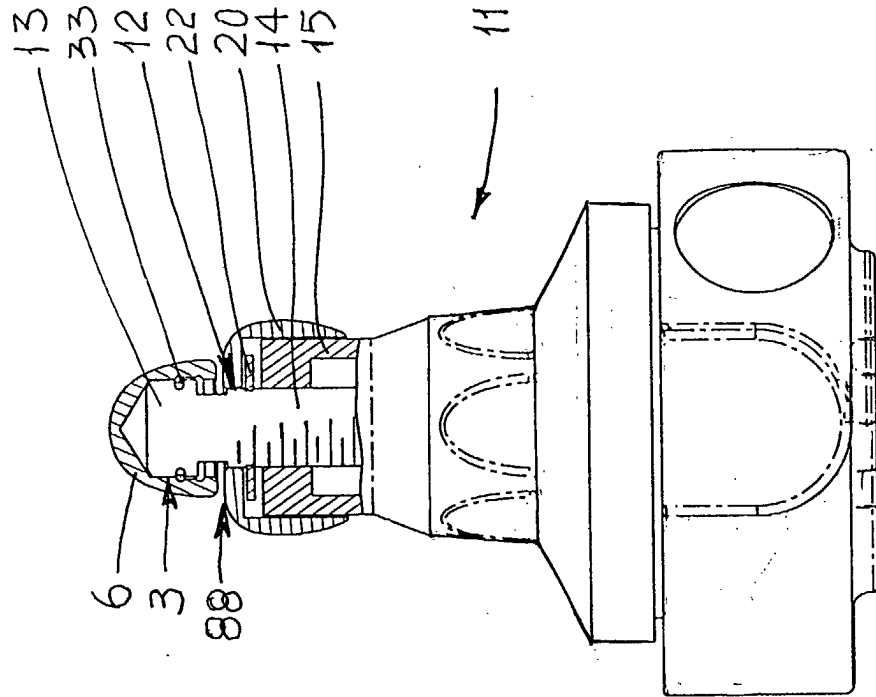

FIG. 7

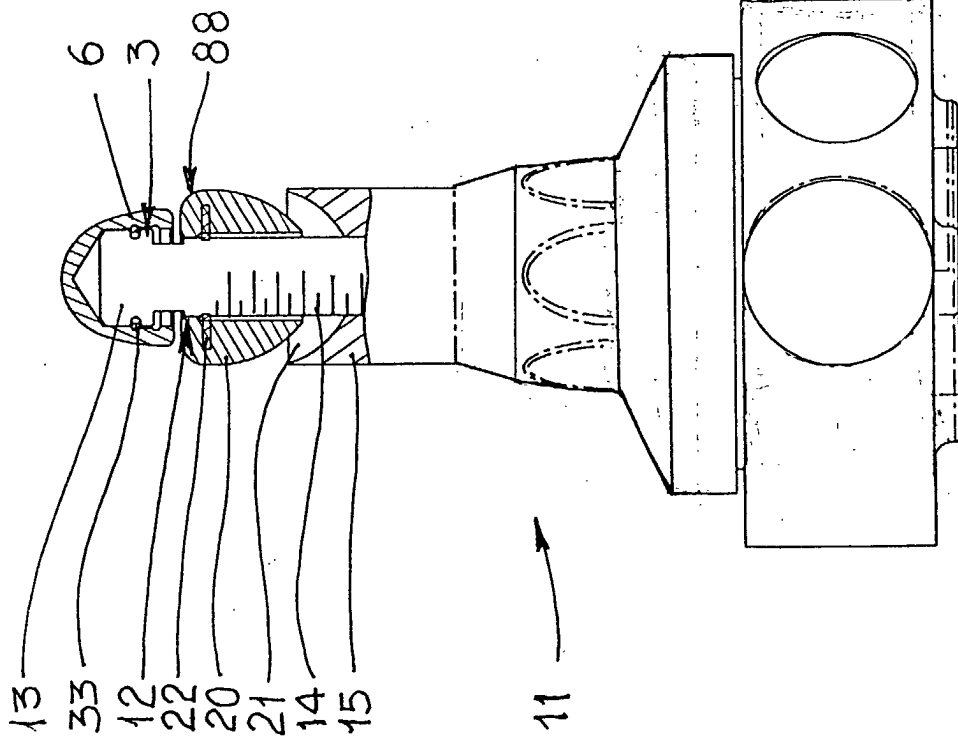

FIG. 8



European Patent
Office

EUROPEAN SEARCH REPORT

Application Number
EP 01 83 0507

DOCUMENTS CONSIDERED TO BE RELEVANT			
Category	Citation of document with indication, where appropriate, of relevant passages	Relevant to claim	CLASSIFICATION OF THE APPLICATION (Int.Cl.7)
A	DE 34 26 026 A (KROME ET AL.) 16 January 1986 (1986-01-16) * page 9, paragraph 4 - page 10, paragraph 3; figure 2 *	1, 3	B67D1/14
A	DE 38 33 907 A (FELLER) 10 August 1989 (1989-08-10)		
A	GB 790 140 A (GASKELL & CHAMBERS) 5 February 1958 (1958-02-05)		
The present search report has been drawn up for all claims			TECHNICAL FIELDS SEARCHED (Int.Cl.7)
			B67D
Place of search	Date of completion of the search	Examiner	
THE HAGUE	16 April 2002	Deutsch, J.-P.	
CATEGORY OF CITED DOCUMENTS		T : theory or principle underlying the invention E : earlier patent document, but published on, or after the filing date D : document cited in the application L : document cited for other reasons & : member of the same patent family, corresponding document	
X : particularly relevant if taken alone Y : particularly relevant if combined with another document of the same category A : technological background O : non-written disclosure P : intermediate document			

EPO FORM 1503 03/82 (P04001)

**ANNEX TO THE EUROPEAN SEARCH REPORT
ON EUROPEAN PATENT APPLICATION NO.**

EP 01 83 0507

This annex lists the patent family members relating to the patent documents cited in the above-mentioned European search report. The members are as contained in the European Patent Office EDP file on
The European Patent Office is in no way liable for these particulars which are merely given for the purpose of information.

16-04-2002

Patent document cited in search report		Publication date	Patent family member(s)	Publication date
DE 3426026	A	16-01-1986	DE 3426026 A1	16-01-1986
DE 3833907	A	10-08-1989	DE 8713372 U1	19-11-1987
			DE 3833907 A1	10-08-1989
			DK 554888 A	06-04-1989
GB 790140	A	05-02-1958	NONE	