



(12) **EUROPEAN PATENT APPLICATION**

(43) Date of publication:
02.10.2002 Bulletin 2002/40

(51) Int Cl.7: **H01H 59/00**

(21) Application number: **02252164.5**

(22) Date of filing: **26.03.2002**

(84) Designated Contracting States:
**AT BE CH CY DE DK ES FI FR GB GR IE IT LI LU
MC NL PT SE TR**
Designated Extension States:
AL LT LV MK RO SI

(72) Inventor: **Seki, Tomonori, c/o Omron Corporation
Shimogyo-ku, Kyoto-shi, Kyoto 600-8530 (JP)**

(74) Representative: **Calderbank, Thomas Roger et al
MEWBURN ELLIS
York House
23 Kingsway
London WC2B 6HP (GB)**

(30) Priority: **27.03.2001 JP 2001089900**

(71) Applicant: **Omron Corporation
Kyoto-shi, Kyoto-fu, 600-8530 (JP)**

(54) **Electrostatic micro-relay, radio device and measuring device using the electrostatic micro-relay, and contact switching method**

(57) Signal lines (5a, 5b) formed on a fixed substrate 1 are arranged on the same straight line. A movable substrate (2) is elastically supported on the fixed substrate (1) through beam portions (11) provided at two positions which are point-symmetrical with each other with a movable contact (16) centered thereon. At least portions opposing the signal lines (5a, 5b) are removed from the movable substrate (2). The movable contact (16) is elastically supported at two points that are orthogonal to the straight line on which the signal lines (5a, 5b) are arranged and do not face the signal lines (5a, 5b). A pair

of protrusions 17 are formed at positions at which after closing the contacts, if a voltage were applied between the fixed electrode 4 and the movable electrode 12 without the protrusion, the fixed substrate 1 and the movable substrate 2 would contact each other following the contact between the fixed contact 7 and the movable contact 16, in a point-symmetrical manner with the movable contact 16 centered thereon. With this arrangement, it is possible to provide an electrostatic micro-relay which has a simple and small-size structure that is easily manufactured at low costs, and is superior in high-frequency characteristics with a suitable contact release force.

[Fig. 1]

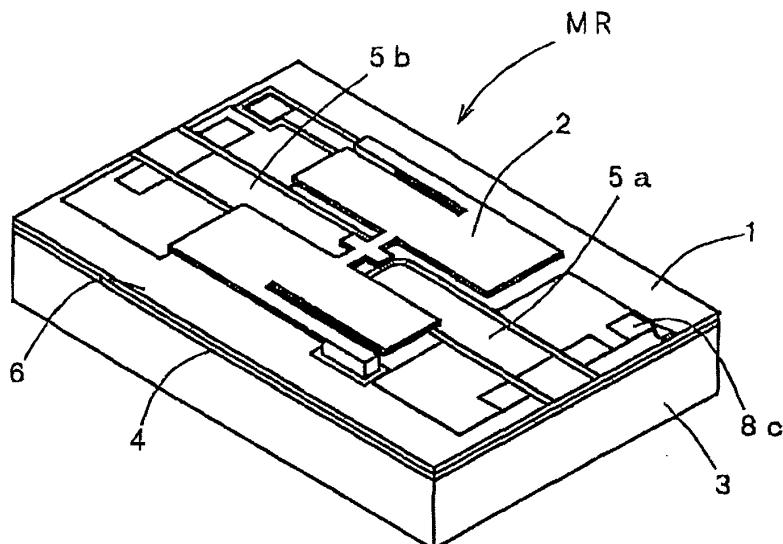

Description

[0001] The present invention relates to an electrostatic micro-relay which switches a signal line by driving based on an electrostatic attraction force generated between electrodes, a radio device and a measuring device using the electrostatic micro-relay, and a contact switching method.

[0002] Conventionally, as electrostatic micro-relays, for example, those disclosed in Japanese Patent Application Laid-Open Nos. 2000-164104 and 2000-113792 have been known.

[0003] In the former, a voltage is applied between electrodes to generate an electrostatic attraction force to drive a movable substrate, so that a movable contact is made in contact with a fixed contact to allow signal lines provided on the fixed substrate in parallel with each other to be electrically connected. In the movable substrate, slits are formed on both sides of the movable contact and protrusions are formed on the lower surface at four positions, thereby increasing the contact release force.

[0004] In the latter, a movable substrate is elastically supported on a fixed substrate at two portions, so that signal lines are formed on the fixed substrate so as to be aligned on the same straight line, and fixed electrodes disposed on both of the sides are commonly used as high-frequency GND electrodes.

[0005] However, in the case of the former device, since the signal lines are provided in parallel with each other, it is not suitable for switching of high frequency signals. The protrusion contacted an opposing substrate before closing the contacts; however, it cannot be said that the position is the most suitable position in order to increase the operation characteristics.

[0006] In contrast, although the latter is suitable for switching of high frequency signals, it fails to take into consideration the structure of the protrusion and the like for increasing the contact release force. Even when the above-mentioned protrusion is simply adopted, it is difficult to obtain desired operation characteristics unless the most suitable position for providing the protrusion is not specified.

[0007] Accordingly, the present invention has been devised to solve the above-mentioned problems, and an object thereof is to provide an electrostatic micro-relay which has a simple and small-size structure that is easily manufactured at low costs and which provides a suitable contact release force, a radio device and a measuring device using the electrostatic micro-relay, and a contact switching method.

[0008] In order to solve the above-mentioned object, in an electrostatic micro-relay which drives a movable substrate based on an electrostatic attraction force generated in a case of applying a voltage between a fixed electrode having a fixed substrate and a movable electrode having the movable substrate supported on the fixed substrate through a beam portion, and which elec-

trically switches a fixed contact formed on the fixed substrate and a movable contact formed on the movable substrate, an protrusion is provided on at least one of the fixed substrate or the movable substrate, and the protrusion is provided on a position, at which the fixed contact comes in contact with the movable contact and then the fixed substrate and the movable substrate contact each other, upon applying the voltage between the fixed electrode and the movable electrode without providing the protrusion.

[0009] With this arrangement, although this device has a structure which is suitable for switching high frequency signals, it can switch the contact release force to two steps in accordance with changes in the electrostatic attraction force. More specifically, within a range having a weak electrostatic attraction force, the protrusion does not contact the opposing substrate, so that the movable substrate is easily deformed in accordance with the electrostatic attraction force. In contrast, within a range having a strong electrostatic attraction force, the protrusion is allowed to contact the opposing substrate, so that the movable substrate has a greater elastic force. Moreover, the protrusion is provided on a position, at which the fixed contact comes in contact with the movable contact and then the fixed substrate and the movable substrate contact each other, upon applying the voltage between the fixed electrode and the movable electrode without providing the protrusion. Therefore, the elastic force of the movable substrate on the movable contact side can be changed at the most suitable position for an electrostatic attraction force curve, thereby making it possible to improve the contact release property.

[0010] It is preferable that if another protrusion is arranged on a position, at which said fixed electrode and the movable electrode contact each other after coming in contact with the protrusion, of at least one of the fixed substrate or the movable substrate upon applying the voltage between the fixed electrode and the movable electrode, the elastic force on the movable contact side becomes large to be capable of taking along with the electrostatic attraction force curve whenever the protrusion is contacted the opposing substrate, thereby obtaining the suitable contact release force.

[0011] The protrusion may be made of an insulating material.

[0012] Moreover, it is preferable that if neither said fixed electrode or said movable electrode is arranged on a position, which contacts said protrusion, of said fixed substrate or said movable substrate which are different from a substrate provided with said protrusion, organic substances are not attached between the protrusion and the opposing electrode, thereby obtaining a stable operation characteristics based on the design over a long period.

[0013] It is noted that the electrostatic micro-relay having the above-mentioned structure is suitable for switching of contacts in equipment for dealing with high

frequency signals such as a radio device, a measuring device and the like.

[0014] In the drawings:

Fig. 1 is an assembling perspective view of an electrostatic micro-relay in accordance with a first embodiment;

Fig. 2 is an exploded perspective view of Fig. 1;

Fig. 3 is a perspective view that shows a state in which a movable substrate shown in Fig. 2 is viewed from the opposite side;

Fig. 4 is a cross-sectional view that shows a processing sequence of the electrostatic micro-relay shown in Fig. 1;

Fig. 5 is a schematic drawing that shows an operation state of the electrostatic micro-relay shown in Fig. 1;

Fig. 6 is a graph that shows the relationship among the gap dimension and the electrostatic attraction force between the fixed substrate and the movable substrate and the elastic force of the movable substrate;

Fig. 7 is a block diagram that shows a state in which the electrostatic micro-relay of Fig. 1 is adopted in a radio device;

Fig. 8 is a block diagram that shows a state in which the electrostatic micro-relay of Fig. 1 is adopted in a measuring device;

Fig. 9(a) and Fig. 9(b) are a plan view and a cross-sectional view of an electrostatic micro-relay in accordance with another embodiment, respectively; and

Fig. 10(a) and Fig. 10(b) are a plan view and a cross-sectional view of an electrostatic micro-relay in accordance with another embodiment, respectively.

[0015] Embodiments according to the present invention will be described with reference to attached drawings below.

[0016] Figs. 1 and 2 show an electrostatic micro-relay according to the present invention. This electrostatic micro-relay has a configuration in which a movable substrate 2 is provided on an upper surface of a fixed substrate 1.

[0017] The fixed substrate 1 has a configuration in which a fixed electrode 4 and signal lines 5a, 5b are formed on an upper surface of a glass substrate 3. The surface of the fixed electrode 4 is coated with an insulation film 6. The signal lines 5a, 5b are arranged along the same straight line, and have fixed contacts 7a, 7b that are adjacent to each other on the center of the glass substrate 3 with a predetermined gap. The signal lines 5a, 5b are respectively connected to connection pads 8a, 8b. Moreover, a connection pad 8c is formed on the side of the signal line 5b through a wiring pattern 9a. A movable electrode 12 of the movable substrate 2 is electrically connected to the wiring pattern 9a and the con-

nection pad 8c. A voltage-applying connection pad 8d and a connection pad 8e connected to GND are formed on the fixed electrode 4. The connection pad 8e has a function of preventing signal leak when a high-frequency signal is transmitted through the signal lines 5a, 5b.

[0018] As shown in Fig. 3, the movable substrate 2 has a configuration that the movable electrode 12 is evenly supported by two first beam portions 11 extending from a support portion 10, which is elected on the upper surface of the fixed substrate 1, in a side direction. The movable electrode 12 is electrically connected to the connection pad 8c through the first beam portions 11, the support portion 10, and the printed wiring 9a provided on the upper surface of the fixed substrate 1. A contact base 14 is elastically supported in the center of the movable electrode 12 by a pair of second beam portions 13. A movable contact 16 is provided on the lower surface of the contact base 14 through the insulating film 15. The movable contact 16 comes into contact with and is separated from the fixed contact 7 to switch the signal lines 5a, 5b. Moreover, protrusions 17 are respectively formed on the lower surface of the movable electrode 12 at positions that are point-symmetrical with each other with the movable contact 16 centered thereon. More specifically, the protrusions 17 are provided on a position at which the fixed contact 7 comes in contact with the movable contact 16 and then the fixed electrode 4 and the movable electrode 12 contact each other upon applying a voltage between the fixed electrode 4 and the movable electrode 12 without providing the protrusion 17. Thus, when an electrostatic attraction force is exerted and the movable substrate 2 is deformed, the protrusions 17 always contacts the fixed substrate 1 before the contacts are closed. Then, the rate of an increase in the release force after the contact and a resulting reduction in contacting force is set to an optimal state. Moreover, the protrusions 17 are formed such that the distance between the movable electrode 12 and the fixed electrode 4 is not more than 1/3 of the gap between the separated fixed substrate 1 and the movable substrate 2 at the time of contacting against the fixed substrate 1. With this arrangement, the electrostatic attraction force becomes rapidly greater at the time when the protrusions 17 contacts the fixed substrate 1, thereby allowing the movable electrode 12 to securely adsorb to the fixed electrode 4.

[0019] Here, the protrusions 17 approach to the opposing fixed electrode 4 as compared with the other portion (movable electrode 12), therefore, the electrostatic attraction force becomes greater, so that the electric field concentrates. Here, when there are foreign matters on the peripheral area, the foreign matters are attracted by the protrusions 17 having the concentrated electric field, and adhere thereto. In this case, the height of the protrusions 17 might change, thereby causing instability in the operation characteristics. Therefore, as shown in Fig. 2, non-electrode sections 18 from which the fixed electrode 4 has been removed are formed at portions

opposing the protrusions 17. However, when the protrusions 17 are formed by an insulating material such as an oxide film, the non-electrode sections 18 are not necessarily required since the generated electrostatic attraction force is suppressed. Moreover, in the case when the protrusions 17 are formed to have a semi-column shape, it becomes possible to suppress the electric field concentration, and consequently to provide a structure that is less likely to attract foreign matters.

[0020] Next, a manufacturing method for an electrostatic micro-relay MR having the above-mentioned configuration will be described.

[0021] First, as shown in Fig. 4(b), a fixed electrode 4 and fixed contacts 7a, 7b (only 7a is shown herein) are formed on a glass substrate 3, which is made PYREX and the like, shown in Fig. 4(a). At the same time, a printed wiring 9a, a connection pad 8a and the like, which are not shown in Fig. 4, are formed thereon. Then, an insulating film 6 is formed on the fixed electrode 4 so that the fixed substrate 1, shown in Fig. 4(c), is completed. Here, as the insulating film 6, a silicon oxide film having a dielectric constant of 3 to 6 or a silicon nitride film having a dielectric constant of 7 to 8 may be used; thus, it becomes possible to obtain a greater electrostatic attraction force, and consequently to increase a contacting force.

[0022] Here, as shown in Fig. 4(d), in order to form a contact-to-contact gap on the under surface of an SOI wafer made of a silicon layer 101, a silicon oxide layer 102 and a silicon layer 103 that are stacked in this order from the top, for example, a wet etching process is carried out using TMAH having a silicon oxide film as a mask so that, as shown in Fig. 4(e), a supporting portion 10 and protrusions 17 downwardly protruding are formed. Then, as shown in Fig. 4(f), after providing an insulating film 15, a movable contact 16 is formed.

[0023] Next, as shown in Fig. 4(g), the above-mentioned SOI wafer 100 is integrally joined to the fixed substrate 1 through an anodic bonding process. Further, as shown in Fig. 4(h), the upper surface of the SOI wafer 100 is subjected to an etching process using an alkali etching solution such as TMAH, KOH and the like, down to the silicon oxide layer 102 that is an oxide film to make it thinner. Moreover, the oxide silicon layer 102 is removed by a fluorine-based etching solution so as to expose the silicon layer 103, that is, the movable electrode 12, as shown in Fig. 4(i). Then, a rapping etching process is carried out by dry etching using RIE or the like, so as to cut out first and second beam portions 11, 13, thereby completing the movable substrate 2. Here, the fixed substrate 1 is not limited to the glass plate 3, and this may be formed by a mono-crystal silicon substrate at least the upper surface of which is coated with an insulating film 6.

[0024] Next, an operation of the electrostatic micro-relay MR having the above-mentioned configuration will be described with reference to a schematic view of Fig. 5.

[0025] In a state where no voltage is applied between the both electrodes and no electrostatic attraction force is generated, as shown in Fig. 5(a), the first beam portion 11 is not elastically deformed to maintain a state of horizontally extending from the support member 10, so that the movable substrate 2 opposes to the fixed substrate 1 with a predetermined gap. Therefore, the movable contact 16 opens and separates from the fixed contacts 7a, 7b.

[0026] Here, when applying a voltage between the two electrodes to generate an electrostatic attraction force, the first beam portion 11 is elastically deformed and the movable substrate 2 approaches to the fixed substrate 1. Thus, as shown in Fig. 5(b), the protrusions 17 contact the fixed substrate 1. As shown in Fig. 6, the electrostatic attraction force tends to increase as the distance between the electrodes becomes smaller. Here, provision is made so that when the protrusions 17 approaches up to about on the fixed substrate 1, the electrostatic attraction force exerted between the two electrodes 4 and 12 abruptly increases. Therefore, the movable substrate 2 also subjects the peripheral portion of each protrusion 17 to a partial elastic deformation, so that the movable electrode 12 is attracted to adhere to the fixed electrode 4. As a result, as shown in Fig. 5(c), the movable contact 16 and the fixed contact 7 are closed. After the movable contact 16 has contacted the fixed contact 7, the second beam portion 13 is deflected in addition to the first beam portion 11 as shown in Fig. 5(d) so that the movable electrode 12 is attracted to adhere to the fixed electrode 4. Therefore, since the peripheral movable electrode 12 is attracted to adhere to the fixed electrode 4, the movable contact 16 is pressed onto the fixed contact 7 through the second beam portion 13. For this reason, no irregular contact occurs, and it becomes possible to improve the contact reliability.

[0027] At this time, supposing that forces of the first and second beam portions 11, 13 that pull the movable electrode 12 upward are F_{s1} , F_{s2} , that a force that is exerted by the elastic deformation of the periphery of each protrusion from the contact of the protrusion 17 to the close of the contacts, and pulls the movable electrode 12 upward is F_{s3} , that an electrostatic attraction force exerted between the movable electrode 12 and the fixed electrode 4 through the insulating film 6 is F_e , and that a drag exerted from the surface of the insulating film 6 is F_n , these forces have the relationship indicated by the following equation (1); therefore, by properly designing factors, such as the spring coefficients of the first and second beam portions 11, 13, the initial gap between the movable electrode 12 and the fixed electrode 4, and the thickness of the contact, it is possible to make F_n , F_{s1} smaller, and consequently to prevent a reduction of F_{s2} , that is, a reduction of a contacting force (from an optimal model).

[Equation 1]

$$F_e = F_{s1} + F_{s2} + F_{s3} + F_n$$

[0028] Thereafter, when the applied voltage between the two electrodes is removed, not only the elastic forces of the first and second beam portions 11, 13, but also an elastic force generated due to the deformation of the periphery of the protrusion 17, can be exerted as a contact release force. Therefore, even when adhesion and stick, etc., are exerted between the contacts, it becomes possible to positively open and separate the contacts. After the contacts have been opened and separated, the movable substrate 2 is allowed to return to the original position by the elastic force on the periphery of the protrusion 17 up to the release of the protrusion 17 after the opening of the contacts, and by the elastic force by the first beam portion 11 after the release of the protrusion 17.

[0029] In this manner, in the above-mentioned embodiment, since the protrusion 17 is formed, it becomes possible to greatly increase the contact release force, so that upon removing the applied voltage, the operation of the movable substrate 2 is smoothly carried out.

[0030] Moreover, the entire movable substrate 2 is formed by a silicon wafer of a simple substance, and formed in a laterally point-symmetric manner or a cross-section line-symmetric manner. Therefore, the movable electrode 12 is less susceptible to warping and twisting, and it becomes possible to effectively prevent maloperation and dispersion in the operation characteristics, and also to ensure smooth operation characteristics.

[0031] The electrostatic micro-relay MR having the above-mentioned configuration has a characteristic for transmitting DC currents up to high-frequency signals preferably with little loss; therefore, this can be applied to, for example, a radio device 110 shown in Fig. 7 and a measuring device 120 shown in Fig. 8. In Fig. 7, the electrostatic micro-relay MR is connected between an inner circuit 112 and an antenna 113. In Fig. 8, the electrostatic micro-relay MR is connected to the middle of each signal line connected to an object to be measured (not shown) from an inner circuit 121. In accordance with this configuration, it becomes possible to transmit signals with high precision while reducing the load to an amplifier or the like used in the inner circuit, in comparison with conventional devices. Moreover, since it has a small size and low power consumption, it is effectively applied to a battery-driven radio device and a measuring device a plurality of which are used.

[0032] Here, in the above-mentioned embodiment, the movable substrate 2 is supported by two first beam portions 11; however, this may be supported by three or four beam portions. Thus, it becomes possible to obtain an electrostatic micro-relay which has good area efficiency. More specifically, Fig. 9 shows an arrangement in which the movable substrate 2 is supported by four beam portions. In Fig. 9, the structure is the same as that shown in Fig. 1 except that four beam portions 11

are placed.

[0033] Moreover, the above-mentioned electrostatic micro-relay MR may have a configuration shown in Fig. 10. In other words, in this electrostatic micro-relay, the supporting section 31 is constituted by rectangular frame members installed on the upper face of the fixed substrate 30. The movable substrate 40 is cantilever-supported by the coupling portion 32 from the inner edge of the supporting portion 31. An insulating film 41 is formed on the under surface of the movable substrate 40, and the movable contact 42 is placed on its free-end side. Moreover, a protrusion 43 is formed between the movable contact 42 and the connecting portion 32 so that the movable contact 42 is allowed to contact on the fixing substrate 30 before the closing of the movable contact 42 and the fixed contact 33. In the case when the protrusion 43 is formed at a position at which the movable substrate 40 is allowed to first contact the fixed substrate 30 after the closing of the contacts, it is possible to make the contacting force greater. Further, when the protrusion 43 is further installed, it is preferably installed at a position at which the movable substrate 40 is next allowed to contact on the fixed substrate 30.

[0034] Moreover, in the above-mentioned embodiment, the movable electrode 12 is formed to have a flat shape; however, a recessed section may be formed in the upper surface to have a thin structure. Thus, even it has a light-weight structure, it is possible to further improve the operation and the returning speed while maintaining desired rigidity. Moreover, the movable electrode 12 may be made thicker to have greater rigidity than the beam portion. With this configuration, all the electrostatic attraction force is made to serve as a suction force to the movable electrode 12 so that the electrostatic attraction force is effectively utilized for distorting the first beam portion 11 or the second beam portion 13.

[0035] Furthermore, in the above-mentioned embodiment, the protrusions 17 are provided on the movable substrate 2; however, this may be provided on the fixed substrate 1 or each of the substrates. Here, with respect to the protrusions 17, not less than two pairs of them may be placed between the contact and the supporting portion 10. In this case, another protrusion 17 is placed at a position where, after first contacting the protrusions 17, the fixed substrate 1 and the movable substrate 2 next contact each other. In this manner, the next protrusion 17 may be successively formed so that, in comparison with a case in which only one pair of the protrusions 17 are provided, it becomes possible to further stabilize the contacting force and the release force.

[0036] As clearly described above, in accordance with the present invention, it is possible to provide an electrostatic micro-relay which has a simple and small-size structure that is easily manufactured at low costs through a semiconductor process. Moreover, since the signal lines are arranged on the same straight line and the opposing movable substrates are removed, the device exerts superior high-frequency characteristics.

Since a protrusion is formed on at least either one of the two substrates, it is possible to obtain a desired uniform contacting force at the time of closing contacts, and also to increase the contact release force. In particular, the protrusion is provided on a position at which, if a voltage were applied between the fixed electrode and the movable electrode without the protrusion, the fixed substrate and the movable substrate would contact each other following the contact between the fixed contact and the movable contact; therefore, at the time of opening the contacts, it is possible to exert an optimal contact release force with respect to the electrostatic attraction force curve.

Claims

1. An electrostatic micro-relay (MR) which drives a movable substrate(2) based on an electrostatic attraction force generated in a case of applying a voltage between a fixed electrode(4) having a fixed substrate(1) and a movable electrode(12) having said movable substrate supported on said fixed substrate through a beam portion(11), and which electrically switches a fixed contact (7a, 7b) formed on said fixed substrate and a movable contact(16) formed on said movable substrate, **characterized in that**
 - a protrusion (17) is provided on at least one of said fixed substrate or said movable substrate, and
 - said protrusion is provided on a position, at which said fixed contact comes in contact with said movable contact and then said fixed substrate and said movable substrate contact each other, upon applying the voltage between said fixed electrode and said movable electrode without providing said protrusion.
2. The electrostatic micro-relay according to claim 1, **characterized in that** another protrusion is arranged on a position, at which said fixed electrode and said movable electrode contact each other after coming in contact with said protrusion, of at least one of said fixed substrate or said movable substrate upon applying the voltage between said fixed electrode and said movable electrode.
3. The electrostatic micro-relay according to claim 1, **characterized in that** said protrusion is made of an insulation material.
4. The electrostatic micro-relay according to claim 1, **characterized in that** neither said fixed electrode or said movable electrode is arranged on a position, which contacts said protrusion, of said fixed substrate or said movable substrate which are different from a substrate provided with said protrusion.
5. A radio device(110) **characterized in that** the electrostatic micro-relay according to claim 1 is provided so as to switch an electric signal between an antenna (113) and an inner circuit(112).
6. A measuring device(120) **characterized in that** the electrostatic micro-relay according to claim 1 is provided so as to switch an electric signal between an object to be measured and an inner circuit(121).
7. A contact switching method for driving a movable substrate based on an electrostatic attraction force generated in a case of applying a voltage between a fixed electrode having a fixed substrate and a movable electrode having said movable substrate supported on said fixed substrate through a beam portion, and for electrically switching a fixed contact formed on said fixed substrate and a movable contact formed on said movable substrate, **characterized in that**
 - a protrusion is provided on at least one of said fixed substrate or said movable substrate,
 - said protrusion is arranged at a predetermined height on a position, at which said fixed contact comes in contact with said movable contact and then said fixed substrate and said movable substrate contact each other, upon applying the voltage between said fixed electrode and said movable electrode without providing said protrusion, and
 - said protrusion contacts an opposing substrate and then said fixed contact comes in contact with said movable contact, upon applying the voltage between said fixed electrode and said movable electrode.

[Fig. 1]

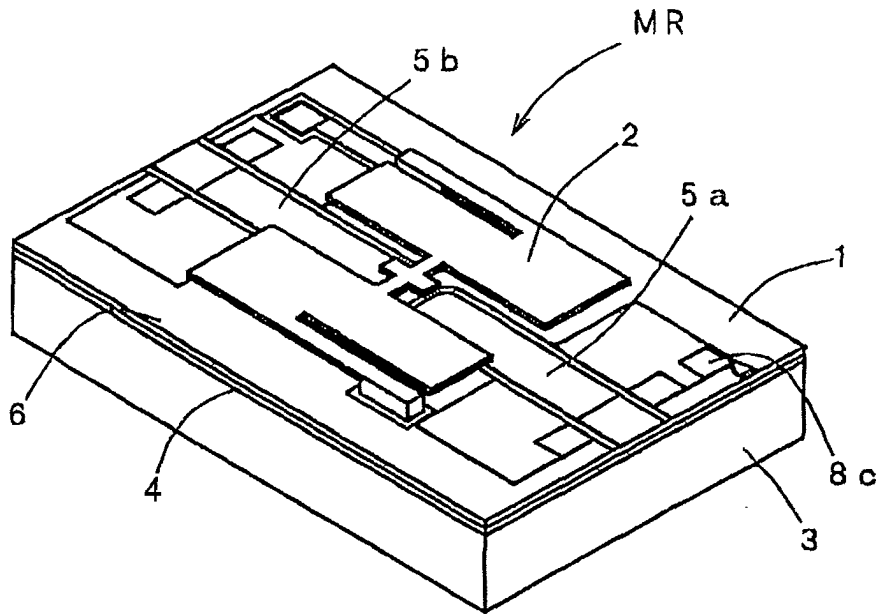

[Fig. 2]

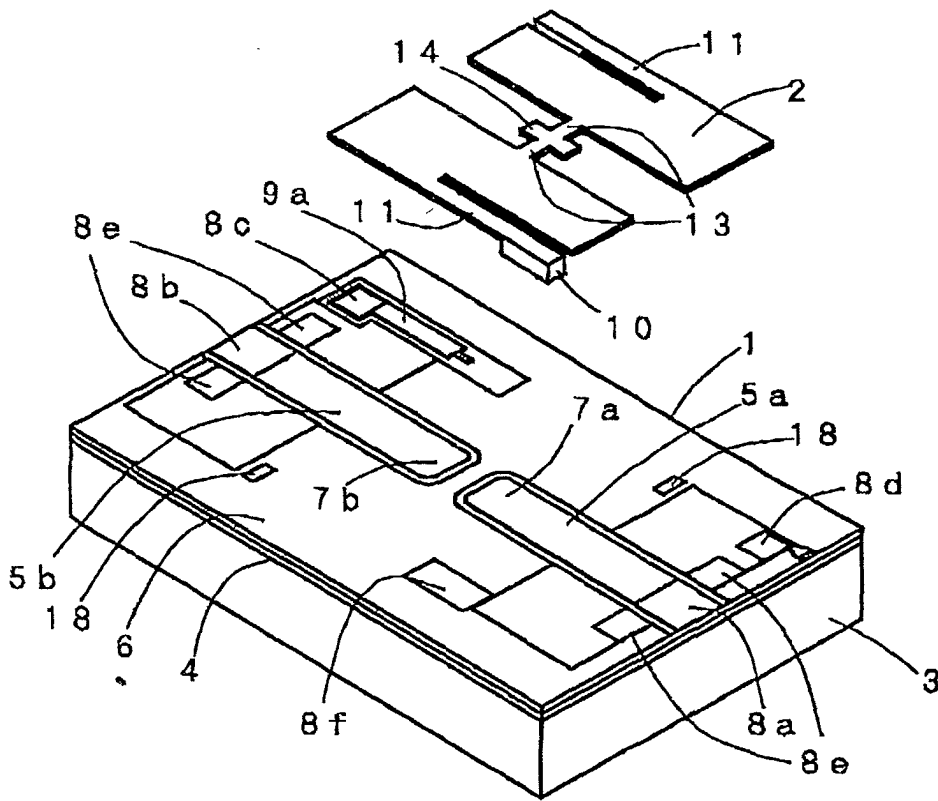

[Fig. 3]

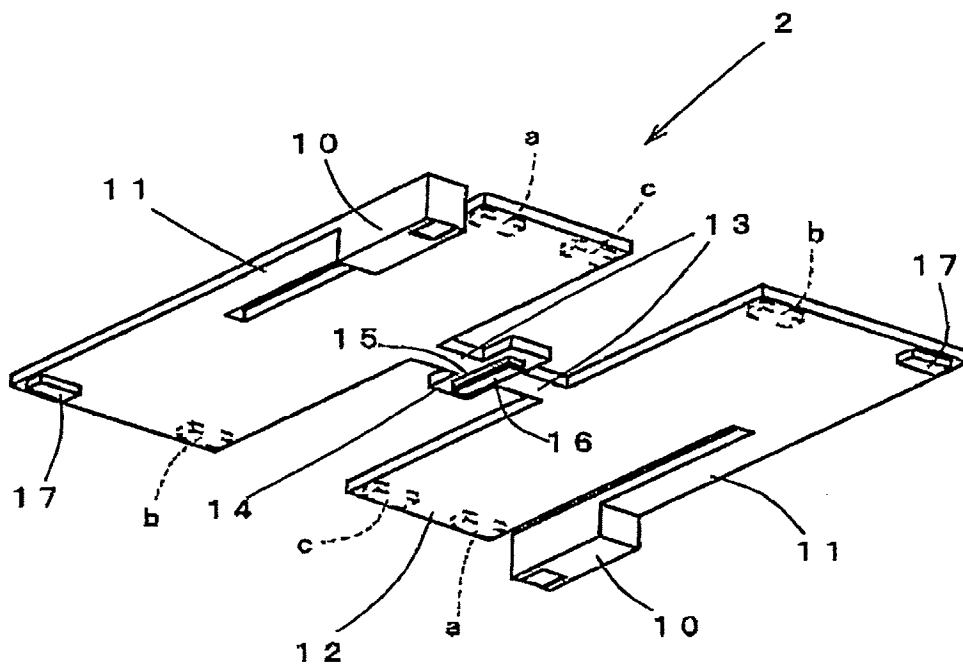

[Fig. 4]

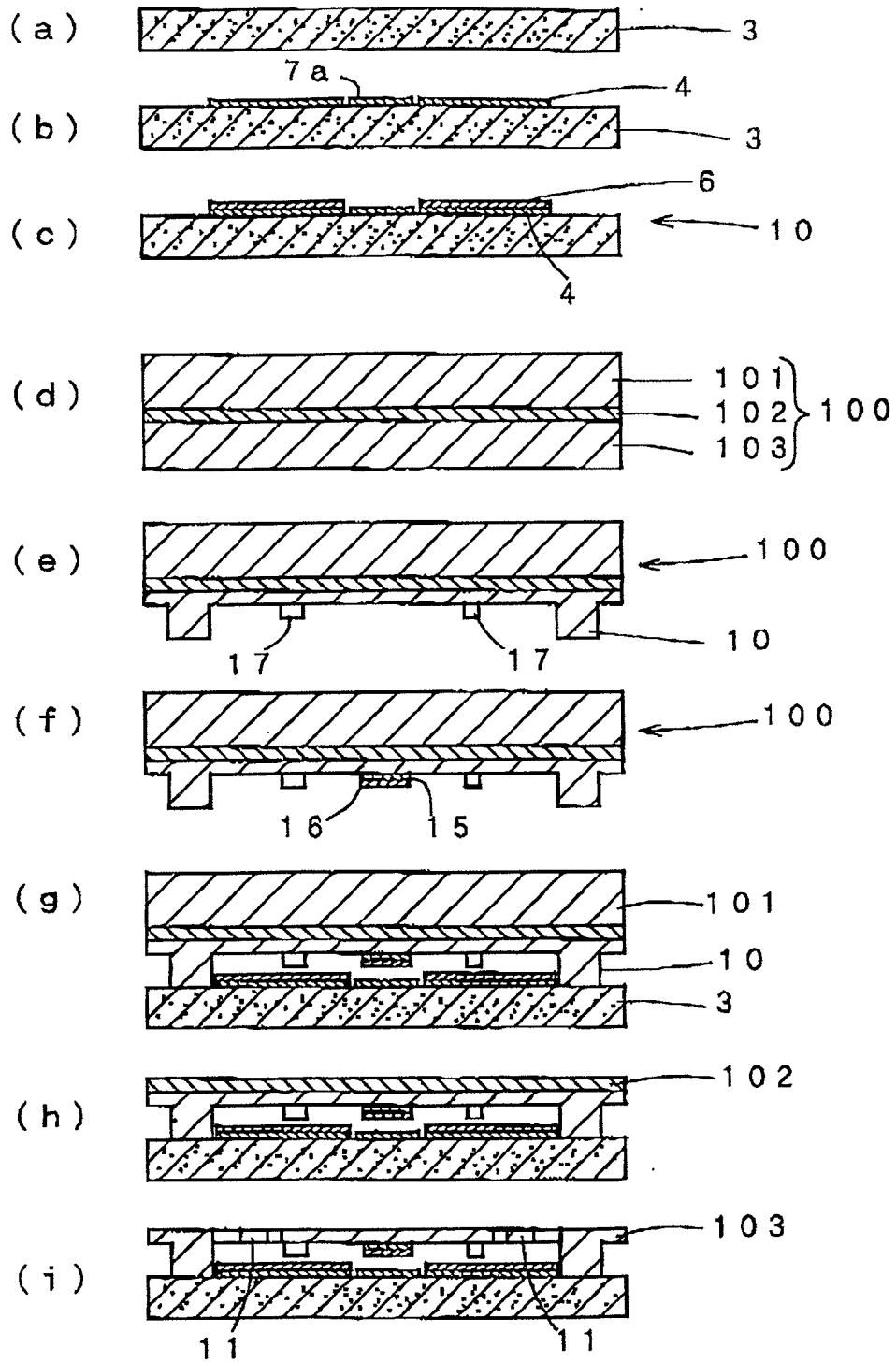

[Fig. 5]

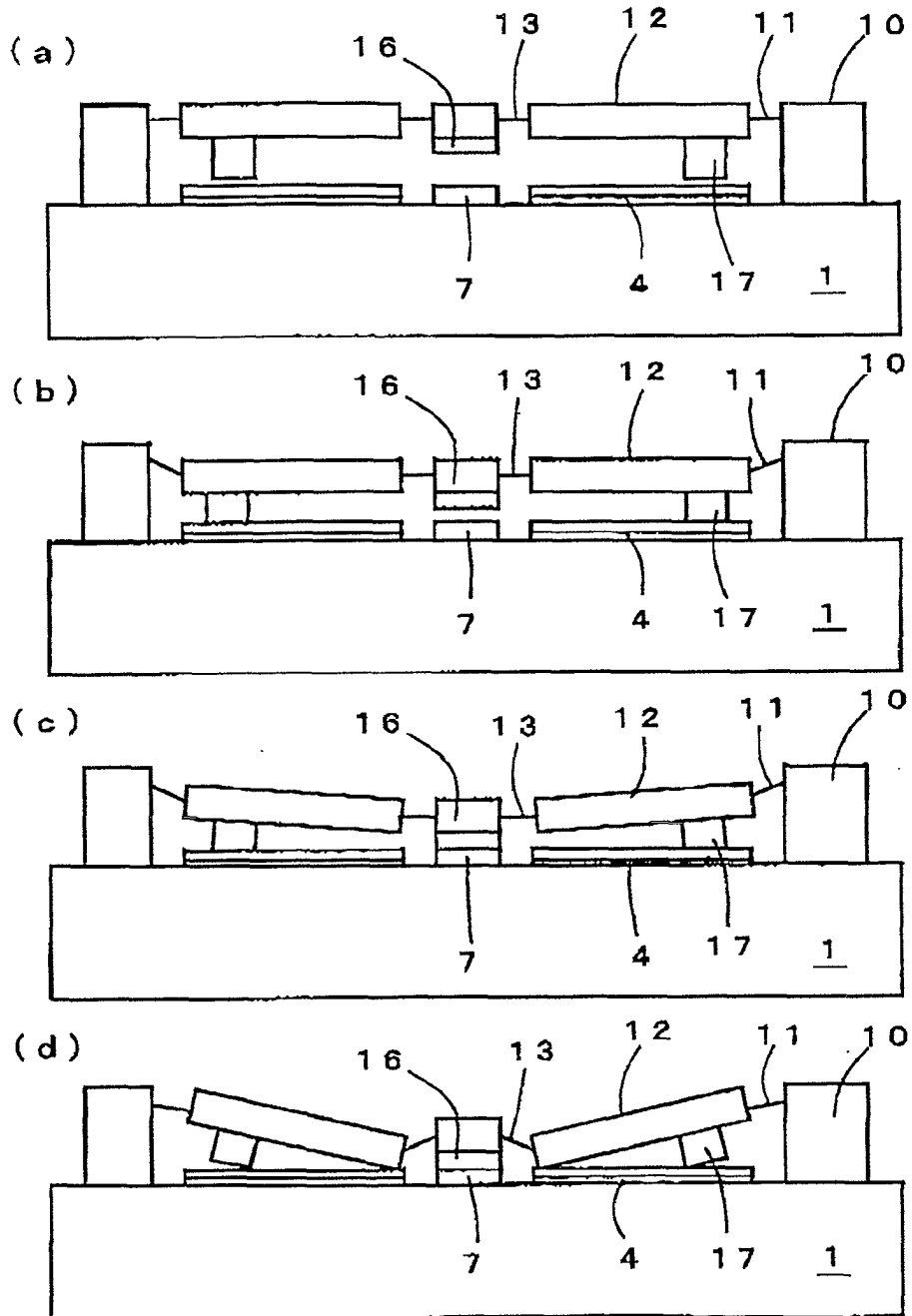

[Fig. 6]

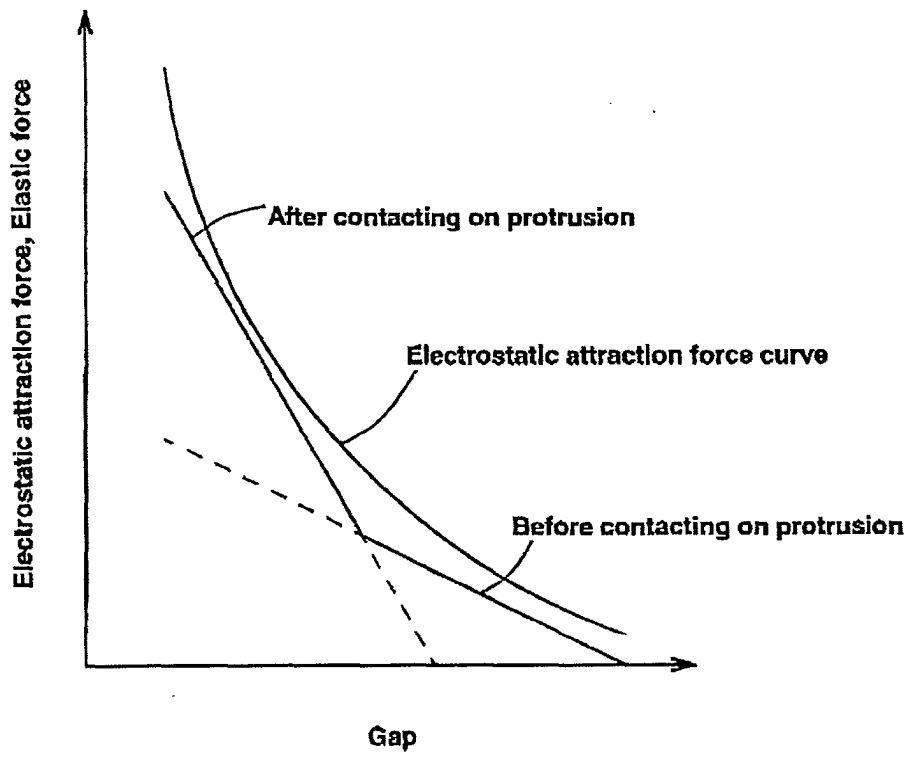

[Fig. 7]

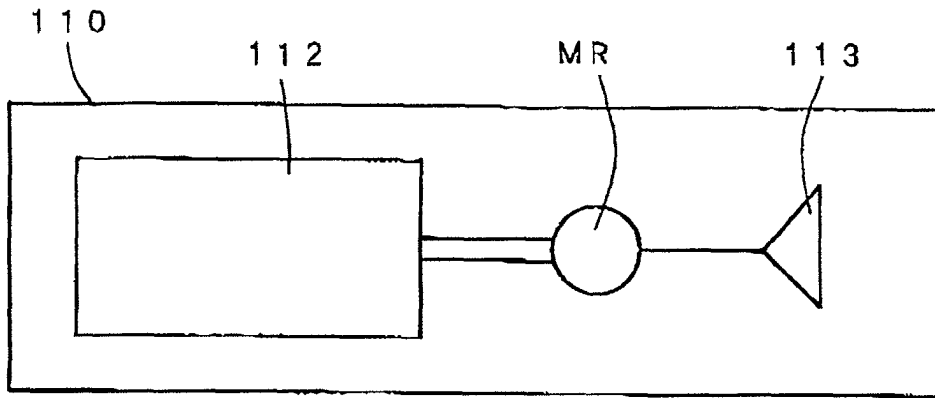

[Fig. 8]

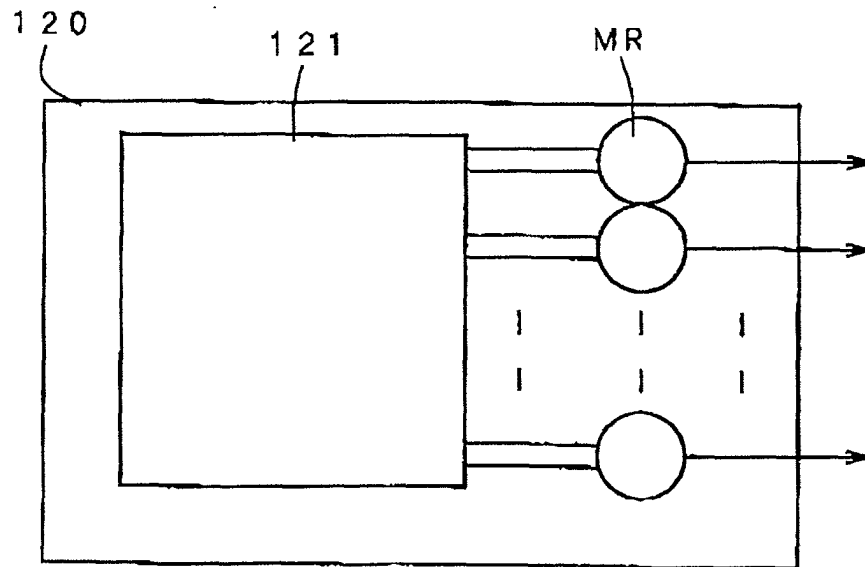

[Fig. 9]

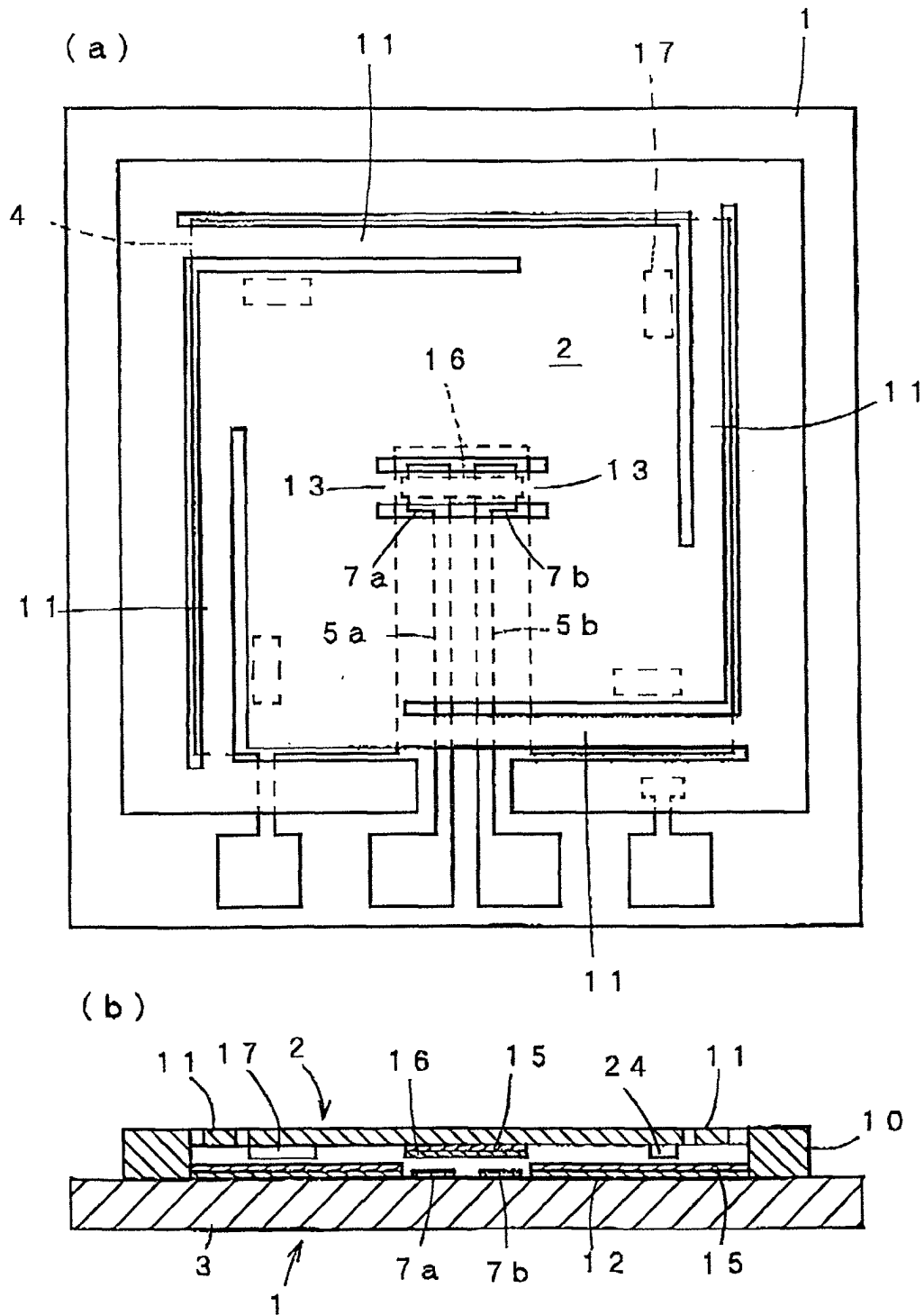

[Fig. 10]

(a)

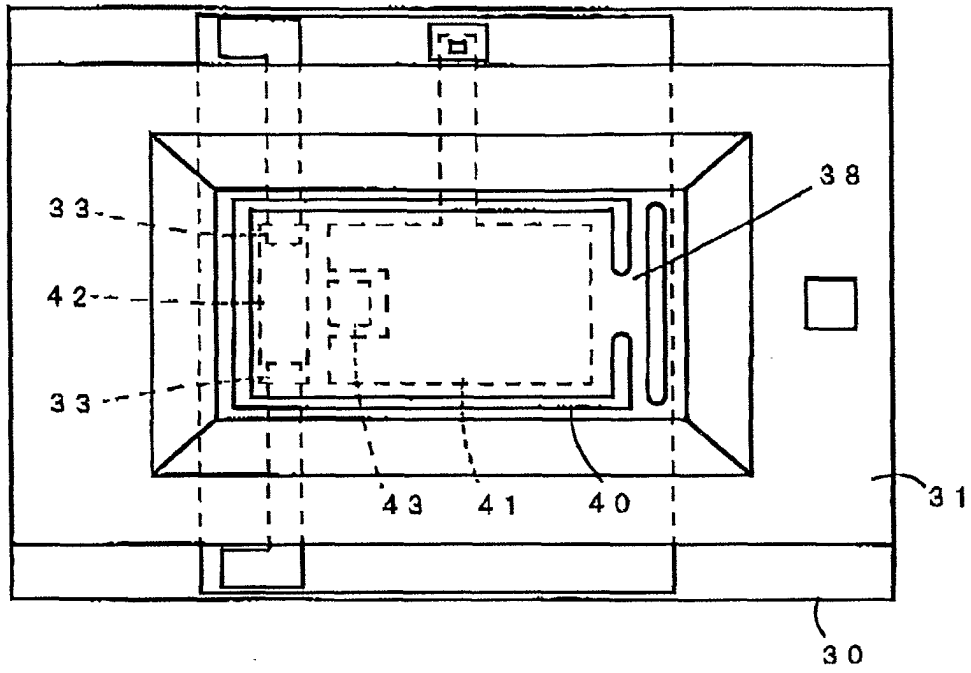

(b)

