



(11) **EP 1 255 652 B1**

(12) **EUROPEAN PATENT SPECIFICATION**

(45) Date of publication and mention of the grant of the patent:
12.12.2007 Bulletin 2007/50

(51) Int Cl.:
B44D 3/12 (2006.01) **B65D 47/28** (2006.01)
B01F 13/10 (2006.01) **B01F 13/00** (2006.01)
B01F 15/00 (2006.01)

(21) Application number: **00982630.6**

(86) International application number:
PCT/US2000/041124

(22) Date of filing: **11.10.2000**

(87) International publication number:
WO 2001/060635 (23.08.2001 Gazette 2001/34)

(54) **SEAL STRUCTURE FOR A PAINT CONTAINER POUR SPOUT**

DICHTUNGSSTRUKTUR FÜR FARBENBEHÄLTER-AUSGIESSER

STRUCTURE DE JOINT POUR BEC VERSEUR DE FLUIDE D'ELEMENT DE COUVERCLE DE RECIPIENT A PEINTURE

(84) Designated Contracting States:
**AT BE CH CY DE DK ES FI FR GB GR IE IT LI LU
MC NL PT SE**

(74) Representative: **Beresford, Keith Denis Lewis et al
BERESFORD & Co.
16 High Holborn
London WC1V 6BX (GB)**

(30) Priority: **15.02.2000 US 504311**

(43) Date of publication of application:
13.11.2002 Bulletin 2002/46

(56) References cited:
US-A- 1 897 890 US-A- 4 127 212
US-A- 4 750 648 US-A- 4 793 528
US-A- 5 358 153 US-A- 5 622 289
US-A- 5 687 885 US-A- 6 053 218
US-A- 6 095 373

(73) Proprietor: **X-Pert Paint Mixing Systems, Inc.
Roseville, MN 55113 (US)**

(72) Inventor: **BOERS, Arie
Plymouth, MN 55442 (US)**

EP 1 255 652 B1

Note: Within nine months from the publication of the mention of the grant of the European patent, any person may give notice to the European Patent Office of opposition to the European patent granted. Notice of opposition shall be filed in a written reasoned statement. It shall not be deemed to have been filed until the opposition fee has been paid. (Art. 99(1) European Patent Convention).

Description**TECHNICAL FIELD**

[0001] This invention relates to mixing paint components, such as colorants, tints and pearls, to create automotive paint formulas. In particular, the present invention is a fluid seal structure positioned between a pour spout and a linearly movable cover element of a paint container lid that can be secured to an original paint component container and is useable with a semi-automated system for dispensing paint components according to a desired paint formula. The fluid seal structure prevents contaminants from entering the original paint component container through the pour spout and prevents undesired leakage of the paint component out of the pour spout and past the cover element.

CROSS REFERENCE TO RELATED APPLICATIONS

[0002] This patent application is a Continuation-In-Part of U.S. Patent Application Serial Number 09/416,871, entitled "Fluid Seal For A Pour Spout Of A Paint Container Lid Member" filed on October 13, 1999, assigned to the same assignee as herein, and incorporated herein by reference thereto. In addition, this patent application is a Continuation-In-Part of U.S. Patent Application Serial Numbers 09/189,338, entitled "Paint Container Lid For A Semi-Automated Automotive Paint Dispensing System," now U.S. Patent Number 6,095,373 issued August 1, 2000; and 09/189,214 entitled "Semi-Automated System For Dispensing Automotive Paint," now U.S. Patent Number 6,053,218 issued April 25, 2000, both of which were filed on November 10, 1998, assigned to the same assignee as herein, and incorporated herein by reference thereto. Further, this patent application is a Continuation-In-Part of U.S. Patent Application Serial Number 09/417,933, entitled "Semi-Automated Automotive Paint Dispensing System;" of U.S. Patent Application Serial Number 09/416,729, entitled "Lid Member For A Paint Container Useable With A Semi-Automated Automotive Paint Dispensing System;" and of U.S. Patent Application Serial Number 09/416,728, entitled "Universal Paint Container Lid Member", all of which were filed on October 13, 1999, assigned to the same assignee as herein, and incorporated herein by reference thereto.

BACKGROUND OF THE INVENTION

[0003] In the automotive body repair industry, paint vendors provide auto body repair businesses, such as body shops and jobbers, with their paint formulas. Generally, these paint formulas are a composition (i.e., mixture) of paint components, such as colorants, tints, pearls, metallics, binders and/or balancers, that, once mixed, produce the desired color of paint to be applied to a repaired vehicle. The paint formulas of the paint vendors are formulated to match the colors that have been

applied to vehicles by new car manufacturers over the years. In addition, these paint formulas include variants, to match the color fading of paint that can occur to a vehicle over years of service. Moreover, the palettes of paint formulas of the paint vendors also have custom colors (i.e., unconventional colors not typically used by vehicle manufacturers) that may be used to produce special finishes for custom or show cars. Hence, paint vendors provide body shops and jobbers with literally thousands of paint formulas for producing the vast spectrum of colors needed in the automotive body repair industry.

[0004] In the past, paint vendors would provide the body shops and jobbers with microfiche containing their paint formulas. Today the paint formulas are stored in computer memory. To determine the particular paint formula for a particular vehicle repair/paint job, a system operator, such as an employee of the body shop or jobber, first obtains the color code from the vehicle. This color code is typically part of the vehicle's identification number. In the case of an unconventional color, to be used to produce a custom paint finish, the code for a particular color is obtained from a catalog. This color code is then entered into the microprocessor of the computer, which accesses the computer memory, and displays, via a monitor, the paint vendor's paint formula which matches the identified vehicle color code.

[0005] The paint formulas are displayed according to the weight of the different paint components for mixing specific quantities of the paint formula, and the order in which the displayed paint components are to be mixed. Typically, paint formula mixing quantities are listed in quart, half gallon and gallon sizes, while the weight of the particular paint components needed to mix the desired quantity of paint, are listed in grams to a precision of a tenth of a gram. Generally, the paint components comprising tints, colorants, pearls and/or metallics are mixed first, while the paint components comprising binders and/or balancers are added last. Depending on the desired color, the paint formula can require just a few paint components, or over a dozen paint components, that must be mixed with a great degree of precision, to achieve a perfect color match.

[0006] Once the system operator determines that the correct desired paint formula is displayed on the computer monitor, the operator places a paint receptacle on a weigh cell that is linked to the microprocessor of the computer. Generally, a receptacle larger than the quantity of paint formula to be mixed is used to accommodate any excess paint inadvertently mixed by the operator. With the receptacle on the weigh cell, the weigh cell is zeroed by the operator, to make ready for the process of adding paint components to the receptacle to mix the desired color paint formula. Generally, the various paint components (of which there are dozens) are stored in containers kept within a rack. The rack has a mechanism that periodically stirs the paint components within the containers, so that the various paint components are ready to be dispensed as part of the paint formula mixing process.

Typically, these containers are the original quart and gallon sized metal containers within which the paint components are shipped to the body shop or jobber. In metric system countries, these containers are the original one liter and four liter sized metal containers within which the paint components are shipped to the body shop or jobber. The original covers of these containers are replaced by specialized paint container lids that include stirring paddles that work with the stirring mechanism of the rack. These specialized paint container lids also have pour spouts that allow the paint components of the containers to be dispensed (i.e., poured out) into the receptacle atop the weigh cell. The pour spout of the specialized paint container lid is covered by a cover element that helps to protect the paint component within the container from contaminants. The cover element for the pour spout is movable between an opened state in which the paint component can be poured from its container through the pour spout by tipping (i.e., tilting) the container, and a closed state. The specialized paint container lid typically includes a vent to allow air to enter the container to displace the liquid paint component dispensed from the pour spout.

[0007] United States Patent No. 4,750,648 discloses a lid with a manually-operable "guillotine"-type pouring arrangement which is especially adapted for mounting on paint containers intended for car bodywork and which are employed in stirring machines. The lid has at least one latching member for fastening it to an open paint container, a pouring spout with a flat-surfaced opening portion, a sliding element conforming with the opening portion of the pouring spout and being slidable on its flat surface, and a flat spring for urging the sliding element into contact with the pouring spout.

[0008] To reproduce the desired paint formula, the system operator begins by identifying the first listed paint component of the paint formula to be mixed. The operator then pours, by hand, the paint component into the weigh cell supported paint receptacle, until the weight of the paint component dispensed (i.e., poured) into the receptacle matches what is displayed on the computer monitor. The operator continues along on this course (i.e., hand pouring the paint components from their containers), until the correct weight of all paint components, needed to mix the desired color paint formula, have been added to the paint receptacle atop the weigh cell.

[0009] Although the above described system for mixing paint components (according to a paint formula), using the original containers of the liquid paint components and the above described specialized container lids, allows a skilled system operator to dispense the needed paint components to adequately recreate paint colors needed for repair/paint jobs, there are some disadvantages to this system. For example, during the process of dispensing the liquid paint component from the specialized container lid, the liquid paint component often undesirably flows out of the pour spout past the cover element when the cover element is in the closed position.

In addition contaminants can enter the original container through the cover element/pour spout interface thereby adversely affecting the quality of the paint component contained within the original container. Moreover, to mix a desired paint formula requires that the paint components be added to the paint receptacle, atop the weigh cell, with a great degree of accuracy. This accuracy, as stated earlier, is typically to a precision of 0.1 grams. For even a highly skilled operator this great degree of precision is difficult to obtain when hand pouring the paint components needed to mix the desired paint formula. It is especially difficult when many paint components must be poured into the paint receptacle in order to duplicate the paint formula.

[0010] The most common error on the part of the system operator of the body shop or jobber is over pouring which is due primarily to the manual labor intensive nature of the paint component dispensing process. Over pouring occurs when the weight of the paint component added to the receptacle atop the weigh cell, exceeds the weight of the component shown on the computer display for the desired paint formula. When this happens, the microprocessor of the computer recalculates the weights of the other paint components that need to be added to the receptacle to compensate for the over poured component. This recalculation is done automatically by the microprocessor since the weigh cell is linked to the computer. Based upon this recalculation, the system operator then needs to re-pour the other paint components to offset the over poured component of the paint formula.

[0011] While this re-pouring task may not be difficult when the paint formula only has a few paint components, the re-pouring task is particularly time consuming when there is a great number of components in the paint formula. Specifically, if an over pouring error is made in the last paint component of a series of ten components of a paint formula, then all of the previous nine components may have to be re-poured to compensate. This re-pouring task may be further complicated if another error is made during the re-pouring of the paint components, as this further error may require that some components be re-poured two or three times until the paint formula is finally accurately reproduced. Hence, over pouring errors can be costly to a body shop or jobber because of the additional man hours needed to mix the paint formula.

[0012] Not only are over pouring errors expensive because of the additional man hours needed to reproduce the paint formula, over pouring errors are also costly in the amount of additional paint formula that is mixed because of the errors. Automotive paint can cost in excess of \$ 100. 00 per quart. An over pouring error of just one pint may translate into an additional cost of \$50.00 that a body shop or jobber may have to absorb, unless this additional paint cost can be justified to an automobile collision insurance carrier. Moreover, this additional paint, if not used in the repair/paint job, becomes a hazardous waste that must be disposed of properly, thereby adding still more costs that are attributable to paint com-

ponent over pouring errors.

[0013] There is a need for an improved system for mixing paint components according to a paint formula. In particular, there is a need for paint container lid members that can be used with the original containers of the paint components, and are compatible with a system for dispensing paint components according to a paint formula that substantially eliminates system operator errors, specifically over pouring errors, that can be costly to a body shop or jobber. The paint container lid members together with the paint component dispensing system should be easy to use, so as not to require a highly skilled operator, and should make better use of an operator's time to allow an operator to mix a greater number of paint formulas during a work day. Moreover, the paint container lid members should prevent contaminants from entering the original paint component container through the pour spout/cover element interface and prevent undesired leakage of the paint component out of the pour spout and past the cover element in the closed state of the cover element. In addition, the paint component lid members and the paint component dispensing system should comply with all regulations and laws governing the handling and mixing of paint components for the duplication of automotive paint formulas.

SUMMARY OF THE INVENTION

[0014] The present invention is a lid member for an original container of a pourable component, as defined according to claim 1. Preferred embodiments of the invention are defined in the dependent claims.

[0015] The lid member of the present invention can be used with the original container of a liquid paint component, and the seal mechanism prevents contaminants from entering the original paint component container through the pour spout/cover element interface. In addition, the seal mechanism of this lid member prevents undesired leakage of the paint component out of the pour spout and past the cover element in the closed state of the cover element. The guide mechanism also helps to prevent undesired leakage of the paint component out of the pour spout, by ensuring that the cover element is accurately aligned with the pour spout and guided during movement of the cover element between the closed and opened states. The securing mechanism ensures that the seal mechanism is properly and securely mounted to the cover element so as to be unaffected by the attributes of the paint component.

[0016] The lid member of the present invention is compatible with a semi-automated system for dispensing liquid paint components from their original containers that virtually eliminates system operator errors, in particular over pouring errors, that can be costly to a body shop or jobber. The lid member and the semi-automated dispensing system are easy to use, and do not require a highly skilled operator, since operator interface with the lid members and the dispensing system is substantially lim-

ited to identifying the desired paint formula, and loading and unloading the proper containers of the liquid paint components to and from the dispensing apparatus. The dispensing system automatically dispenses (i.e., pours) the liquid paint components from their containers, thereby ensuring a highly accurate, precision liquid paint component pour. This highly accurate liquid paint component pour substantially limits the additional cost of the added paint components attributable to over pouring errors. In addition, the lid member of the present invention together with the paint dispensing system makes efficient use of the operator's time, since the operator is free to perform other duties instead of manually pouring the proper amounts of the liquid paint components from their containers. This efficiency gain allows the operator to mix a greater number of paint formulas during a work day. Lastly, the paint component lid member of the present invention, together with the semi-automated dispensing system complies with all regulations and laws (such as being explosion protected) governing the safe handling and mixing of liquid paint components for the duplication of automotive paint formulas.

BRIEF DESCRIPTION OF THE DRAWINGS

[0017] The accompanying drawings are included to provide a further understanding of the present invention and are incorporated in and constitute a part of this specification. The drawings illustrate the embodiments of the present invention and together with the description serve to explain the principals of the invention. Other embodiments of the present invention and many of the intended advantages of the present invention will be readily appreciated as the same become better understood by reference to the following detailed description when considered in connection with the accompanying drawings, in which like reference numerals designate like parts throughout the figures thereof, and wherein:

FIG. 1 is a perspective view illustrating a dispensing and control apparatus of a semi-automated system for dispensing liquid paint components from their original containers in accordance with the present invention.

FIG. 2 is an enlarged perspective view better illustrating the dispensing apparatus of the dispensing system of FIG. 1.

FIG. 3A is a side elevational view of a quart size original paint container and lid member for holding a liquid paint component with a cover element and vent mechanism shown in a closed position.

FIG. 3B is a side elevational view similar to FIG. 3A of the quart size original paint container and lid member for holding a liquid paint component with the cover element and vent mechanism shown in an open position.

FIG. 4 is a perspective view of the quart size lid member shown in FIG. 3A.

FIG. 5 is top elevational view of the paint container and lid member shown in FIG. 3A.

FIG. 6 is partial side elevational view with some parts omitted for clarity of the dispensing apparatus of FIGS. 1 and 2, illustrating a quart size original container of a paint component being loaded into/unloaded from the dispensing apparatus.

FIG. 7 is a partial side elevational view with some parts omitted for clarity similar to FIG. 6, illustrating the quart size original container ready for dispensing of the liquid paint component.

FIG. 8 is a partial side elevational view with some parts omitted for clarity similar to FIG. 7, illustrating the liquid paint component being dispensed from its quart size original container.

FIG. 9A is an enlarged, partial side elevational view of a force applying mechanism for a cover element of the lid member with the cover element shown in a closed position corresponding to FIG. 7.

FIG. 9B is an enlarged, partial side elevational view similar to FIG. 9A with the cover element shown in an open position corresponding to FIG. 8.

FIG. 10 is an enlarged, partial top elevational view of the force applying mechanism shown in FIG. 9.

FIG. 11 is a partial side elevational view with some parts omitted for clarity similar to FIG. 7, illustrating a gallon size original container ready for dispensing of a liquid paint component.

FIG. 12 is a partial side elevational view of an automatic bleeder valve of the semi-automated dispensing system of the present invention with the valve shown in a closed position.

FIG. 13 is a partial side elevational view similar to FIG. 12 illustrating the automatic bleeder valve in an opened position.

FIG. 14A is a sectional view taken along line 14A-14A in FIG. 5 illustrating a background example of a resilient seal mechanism for the cover element/pour spout interface of a lid member.

FIG. 14B is a sectional view taken along line 14B-14B in FIG. 5 illustrating an alternative background example of a resilient seal mechanism for the cover element/pour spout interface of the lid member.

FIG. 14C is a sectional view taken along line 14C-14C in FIG. 5 illustrating another alternative background example of a resilient seal mechanism for the cover element/pour spout interface of the lid member.

FIG. 14D is a sectional view taken along line 14D-14D in FIG. 5 illustrating still a further alternative background example of a resilient seal mechanism for the cover element/pour spout interface of the lid member.

FIG. 14E is a sectional view taken along line 14E-14E in FIG. 5 illustrating a preferred embodiment of a resilient seal mechanism for the cover element/pour spout interface of the lid member in accordance with the present invention.

FIG. 14F is a sectional view taken along line 14F-14F in FIG. 5 further illustrating the preferred embodiment of the resilient seal mechanism.

FIG. 14G is a sectional view taken along line 14G-14G in FIG. 5 further illustrating the preferred embodiment of the resilient seal mechanism.

FIG. 15 is an exploded perspective view of the preferred embodiment of the resilient seal mechanism of FIGS. 5 and 14E.

FIG. 16 is a sectional view similar to FIG. 14G illustrating the preferred embodiment of the seal mechanism shown detached from the lid member.

DETAILED DESCRIPTION OF THE PREFERRED EMBODIMENTS

[0018] A semi-automated dispensing system 10 for dispensing liquid paint components according to a paint formula to form a liquid paint mixture in accordance with the present invention is illustrated generally in FIGS. 1 and 2. The dispensing system 10 generally comprises a dispensing apparatus 12 for dispensing a liquid paint component 14 from its original container 16A and 16B, and a control apparatus 18 for controlling the dispensing apparatus 12. FIGS. 1, 3-8 show the quart size original container 16A having a lid member 20A, while FIG. 11 illustrates the gallon size original container 16B having a lid member 20B. In metric system countries, the lid member 20A fits a one liter size original container and the lid member 20B fits a four liter size original container. The containers 16A and 16B (without the lid members 20A and 20B) are typical cylindrical shaped, metal vessels within which liquid paint components 14, such as tints, colorants, pearls, metallics, binders and balancers (used to mix automotive paint according to a paint formula) are shipped from a liquid paint component manufacturer to customers, such as body shops and jobbers. Beyond their size differences, the quart size and gallon size containers 16A and 16B are substantially identical. Therefore, only the quart size original container will be described with particularity. The lid members 20A and 20B are substantially similar, therefore the quart size lid member 20A will be described with particularity, and only the differences in the gallon size lid member 20B relative to the quart size lid member 20A will be described with particularity.

[0019] As seen best in FIGS. 3A and 3B, the original container 16A is cylindrical shaped having an open top 22A defined by a circumferential lip 24A. As seen best in FIGS. 3-5, the lid member 20A includes a base portion 26A adapted to engage and seal the open top 22A of the container 16A to protect the liquid paint component 14 within the container 16A. The base portion 26A of the lid member 20A includes a pair of spaced, pivotable cam lock mechanisms 28A that are used to releasably secure the lid member 20A to the original container 16A. Each of the cam lock mechanisms 28A is defined by a cam element 30A connected to a cam actuator 32A by way

of a post member 34A. Pivotaly moving the cam actuators 32A by hand, as represented by double headed arrow 36 (see FIG. 4), moves the cam elements 30A into and out of engagement with the lip 24A to secure and release the lid member 20A from the original container 16A.

[0020] The lid member 20A further includes a handle 38A, for easy handling of the original container 16A when the lid member 20A is secured thereto. The handle 38A includes a first portion 39A generally parallel to the lip 24A of the original container 16A, a second portion 41 A (grasped by a user) that extends substantially perpendicular to the first portion 39, and a pair of oppositely directed dispensing system latch lugs 43A positioned at the intersection the first and second portions 39A, 41 A. The purpose of the pair of dispensing system latch lugs 43A will become clear below. In the gallon size lid member 20B, as illustrated in FIG. 11, the pair of oppositely directed dispensing system latch lugs 43B are positioned along the length of the first portion 39B of the handle 38B instead of at the intersection of the first and second portions 39A and 41A as in the quart size lid member 20A. Other than the size differences between the quart size lid member 20A and the gallon size lid member 20B, this different positioning of the dispensing system latch lugs 43A, 43B constitutes the main and only real difference between the lid members 20A and 20B.

[0021] As seen best in FIG. 5, the lid member 20A also includes a liquid paint component pour spout 40A having a rear wall 81A, first and second opposed side walls 83A and 85A, respectively, and a front pour wall 87A. Also as seen in FIG. 5, immediately adjacent to (i.e., to the rear of) the rear wall 81 of the pour spout 40A, the lid member 20A includes first and second spaced guide surfaces 89A and 91A, respectively, the purpose of which will be made clear below. The pour spout 40A is covered by a linearly movable, as represented by double headed directional arrow 42 (see FIGS. 3A and 3B), cover element 44A. The cover element 44A is linearly movable between a closed state (shown in FIG. 3A) and an opened state (shown in FIG. 3B). In the closed state of the cover element 44A, the liquid paint component 14 is prevented from being poured (i.e., dispensed) from the original container 16A through the pour spout 40A. In the opened state of the cover element 44A, the liquid paint component 14 can be poured from the original container 16A through the pour spout 40A by tilting the container 16A using the handle 38A.

[0022] As seen when comparing FIGS. 3A and 3B, the cover element 44A is movable between its closed and opened states via a thumb actuator 46A that is pivotaly secured to the base portion 26A by way of a pivot pin 48A. The thumb actuator 46A is pivotaly movable as shown by double headed directional arrow 47. As seen best in FIG. 4, the thumb actuator 46A is connected to the cover element 44A via a wire loop 50A. When the thumb actuator 46A is positioned as shown in FIG. 3A, the cover element 44A is in its closed state. The thumb

actuator 46A is biased to this normal position in a known manner by a coil spring element 54A (see FIGS. 3A and 3B). The coil spring element 54A acts between the base portion 26A and the thumb actuator 46A. When the thumb actuator 46A is positioned as shown in FIG. 3B, the cover element 44A is in its opened state. The cover element 44A is moved, from its closed state to its opened state, through the connecting wire loop 50A by pivoting the thumb actuator 46A about the pivot pin 48A against the bias of the spring element 54A. The cover element 44A is allowed to return to its closed state from the opened state by simply releasing the thumb actuator 46A. The lid member 20A also includes a rotatable roller element 51A (see FIGS. 4 and 5) that bears against the wire loop 50A to help maintain a seal between the cover element 44A and the pour spout 40A. As seen in FIGS. 3-5, the cover element 44A also includes a slot 49A the purpose of which will be made clear below.

[0023] As seen best in FIGS. 5 and 14A-G, the walls 81 A, 83A, 85A, 87A of the pour spout 40A define a circumferential, planar edge surface 350A, and the cover element 44A includes a planar lower surface 352A. A resilient seal mechanism 354 is positioned at an engagement interface 356 between the circumferential, planar edge surface 350A of the pour spout 40A and the planar lower surface 352A of the cover element 44A. The resilient seal mechanism 354 prevents leakage, upon tilting of the original container 16A, of the liquid paint component 14 out of the pour spout 40A past the cover element 44A in the closed state of the cover element 44A.

[0024] As illustrated in FIG. 14A, in a background example, the resilient seal mechanism 354 is defined by a resilient seal member 357 that covers the entire planar lower surface 352A of the cover element 44A. The resilient seal member 357 comprises a first substrate 358 of a resilient material, such as foam, and a second substrate 360 of a smooth material, such as polyethylene. Alternatively, the second substrate 360 could comprise TEFLON. In a variant, the first substrate 358 has a thickness of approximately 7.62 μm (0.0003 inches) and the second substrate 360 has a thickness of 2.54 μm (0.0001 inches). The resilient seal member 357 is secured, via the first substrate 358, to the planar lower surface 352A of the cover element 44A via a suitable adhesive. The second substrate 360 engages the circumferential, planar edge surface 350A of the pour spout 40A. The smoothness of the second substrate 360 allows the cover element 44A to readily move relative to the pour spout between the open and closed states. As seen in FIG. 14A, the resiliency of the first substrate 358 allows the resilient seal member 357 to conform to the shape of the circumferential, planar edge surface 350A of the pour spout 40A. By conforming to the shape of the pour spout 40A, the resilient seal member 357 provides an excellent fluid seal that prevents contaminants from entering the original container 16A through the pour spout 40A, and prevents leakage, upon tilting of the original container 16A, of the liquid paint component 14 out of the pour

spout 40A past the cover element 44A in the closed state of the cover element 44A.

[0025] FIG. 14B illustrates an alternative background example of a resilient seal member 370. The resilient seal member 370 is defined by a rubber O-ring 372 that is mounted within a circumferentially extending channel 374 in the circumferential, planar edge surface 350A of the pour spout 40A. The resiliency of the rubber O-ring 372 allows the resilient seal member 370 to conform to the shape of the planar lower surface 352A of the cover element 44A. By conforming to the shape of the cover element 44A, the resilient seal member 370 provides an excellent fluid seal that prevents contaminants from entering the original container 16A through the pour spout 40A, and prevents leakage, upon tilting of the original container 16A, of the liquid paint component 14 out of the pour spout 40A past the cover element 44A in the closed state of the cover element 44A.

[0026] FIG. 14C illustrates another alternative background example of a resilient seal member 380. The resilient seal member 380 is defined by a generally U-shaped, rubber seal element 382 having an engagement channel 384 for receiving the circumferential, planar edge surface 350A of the pour spout 40A for mounting the resilient seal member 380 to the pour spout 40A. An upper surface 385 of the seal element 382 includes a circumferential ridge 386 that engages the planar lower surface 352A of the cover element 44A. The resiliency of the ridge 386 allows the resilient seal element 382 to conform to the shape of the planar lower surface 352A of the cover element 44A. By conforming to the shape of the cover element 44A, the resilient seal element 382 provides an excellent fluid seal that prevents contaminants from entering the original container 16A through the pour spout 40A, and prevents leakage, upon tilting of the original container 16A, of the liquid paint component 14 out of the pour spout 40A past the cover element 44A in the closed state of the cover element 44A.

[0027] FIG. 14D illustrates a further alternative background example of a resilient seal member 390. The resilient seal member 390 is defined by a generally U-shaped, rubber seal element 392 having an engagement channel 394 for receiving the circumferential, planar edge surface 350A of the pour spout 40A for mounting the resilient seal member 390 to the pour spout 40A. An upper surface 395 of the seal element 392 includes a circumferential extension 396 that is directed exterior to the pour spout 40A and engages the planar lower surface 352A of the cover element 44A. The dashed line representation of the extension 396 is the normal inoperative state of the extension 396. The solid line representation of the extension 396 is the flexed operative state of the extension 396. The resiliency of the extension 396 allows the resilient seal element 392 to conform to the shape of the planar lower surface 352A of the cover element 44A. By conforming to the shape of the cover element 44A, the resilient seal element 392 provides an excellent fluid seal that prevents contaminants from entering the origi-

nal container 16A through the pour spout 40A, and prevents leakage, upon tilting of the original container 16A, of the liquid paint component 14 out of the pour spout 40A past the cover element 44A in the closed state of the cover element 44A.

[0028] As illustrated in FIGS. 14E-14G, in a preferred embodiment, the resilient seal mechanism 354 is defined by a resilient seal member 450 that covers the entire planar lower surface 352A of the cover element 44A. The resilient seal member 450 comprises a first substrate 452 of a resilient material, and a second substrate 454 of a flexible and smooth material. In one preferred embodiment, the resilient material of the first substrate 452 is high density polyethylene closed cell foam, and the flexible and smooth material of the second substrate 454 is ultra high molecular weight polyethylene plastic sheet. Alternatively, the second substrate 454 could comprise TEFLON. In one preferred embodiment, the first substrate 452 has a thickness of approximately 12.7 μm (0.00050 inches) and the second substrate 454 has a thickness of 5.08 μm (0.00020 inches).

[0029] The resilient seal member 450 is secured, via a securing mechanism 460, to the planar lower surface 352A of the cover element 44A. As seen in FIGS. 14E-14G, 15 and 16, the securing mechanism 460 includes a plurality of spaced protrusions 462 that are integrally formed with the cover element 44A and extend from the planar lower surface 352A thereof. In one preferred embodiment, there are four spaced protrusions 462. The spaced protrusions 462 engage the first and second substrates 452, 454 defining the resilient seal member 450 to secure the substrates 452, 454 (i.e., the resilient seal member 450) to the cover element 44A. To accomplish this securing function, the first substrate 452 includes a plurality of spaced openings 464. In one preferred embodiment, there are four spaced openings 464 that are formed via die cutting. Each of the openings 464 is sized to closely receive one of the protrusions 462 to secure the first substrate 452 against the planar lower surface 352A of the cover element 44A. The protrusions 462 cooperate with the closely fitting openings 464 to hold the first substrate 452 to the cover element 44A via only frictional engagement.

[0030] To further accomplish the securing function of the securing mechanism 460, the second substrate 454 includes a plurality of cup shaped protruding portions 466. In one preferred embodiment, there are four cup shaped protruding portions 466 that are formed in the second substrate 454 during the injection molding process used to form the second substrate 454. Each of the protruding portions 466 is sized to closely receive one of the protrusions 462 to secure the second substrate 454 against the first substrate 452 and to the planar lower surface 352A of the cover element 44A. The protrusions 462 cooperate with the closely fitting cup shaped protruding portions 466 to hold the second substrate 454 to the cover element 44A via only frictional engagement. The second substrate 452 includes an upstanding pe-

ripheral wall 468 that acts to enclose the first substrate 452.

[0031] The first substrate 452 engages the planar lower surface 352A of the cover element 44A, and the second substrate 454 engages the circumferential, planar edge surface 350A of the pour spout 40A. The smoothness of the second substrate 454 allows the cover element 44A to readily move relative to the pour spout 40A between the open and closed states. As seen in FIG. 14E, the resiliency of the first substrate 452 combined with the flexibility of the second substrate 454 allows the resilient seal member 450 to conform to the shape of the circumferential, planar edge surface 350A of the pour spout 40A. In addition, as can be seen when comparing FIGS. 14G and 16, the cup shaped protruding portions 466 slidably receive the protrusions 462 so as to allow some movement of the second substrate 454 relative to the cover element 44A upon compression and extension of the first substrate 452. This movement of the second substrate 454 relative to the cover element 44A is substantially perpendicular to the planar lower surface 352A of the cover element 44A and allows the resilient seal member 450 to engage and conform to the shape of the circumferential, planar edge surface 350A of the pour spout 40A. FIG. 16 illustrates the first substrate 452 in an uncompressed state with a first length L1 existing between the bottom of the protrusions 462 and the bottom of the cup shaped protruding portions 466. FIG. 14G illustrates the first substrate 452 in a compressed state with a second length L2 that is less than the first length L1 existing between the bottom of the protrusions 462 and the bottom of the cup shaped protruding portions 466. By conforming to the shape of the pour spout 40A, the resilient seal member 450 provides an excellent fluid seal that prevents contaminants from entering the original container 16A through the pour spout 40A, and prevents leakage, upon tilting of the original container 16A, of the liquid paint component 14 out of the pour spout 40A past the cover element 44A in the closed state of the cover element 44A. Since the securing mechanism 460 is entirely mechanical in nature, the securing mechanism 460 is unaffected by attributes of paint components 14. Unlike some adhesives which may lose some of their adhesion qualities as a result of prolonged exposure to paint components 14, the securing mechanism 460 is capable of properly securing the resilient seal member 450 to the cover element 44A despite prolonged exposure to paint components 14.

[0032] As seen in FIGS. 14E and 14F, the resilient seal member 450 includes a guide mechanism 470 positioned between the pour spout 40A of the lid member 20A and the movable cover element 44A for guiding and aligning the cover element 44A on the pour spout 40A as the cover element 44A is moved between the closed and opened states. The guide mechanism 470 is defined by the cup shaped protruding portions 466. The protruding portions 466 slidably engage the first and second opposed side walls 83A and 85A (FIG. 14E) of the pour

spout 40A and the first and second spaced guide surfaces 89A and 91A (FIG. 14F) of the lid member 20A for guiding and aligning the cover element 44A on the pour spout 40A during movement of the cover element 44A.

5 As seen in FIGS. 14E and 14F, each of the protruding portions 466 slidably engages only one of the first and second side walls or guide surfaces 83A, 85A, 89A, 91 A.

[0033] As seen in FIGS. 3-4, the base portion 26A of the lid member 20A includes a vent member 53A defining a vent passage 55A that has a first open end 57A and an opposite second open end 59A. The vent passage 55A passes through the base portion 26A such that the first open end 57A communicates with an interior region 61 A of the original container 16A and the second open end 59A communicates with atmosphere. The second open end 59A is sealable by way of a linearly movable plug element 63A. As seen best when comparing FIGS. 3A and 3B, the plug element 63A is linearly movable between a sealed position (see FIG. 3A) wherein a cone shaped end 65A of the plug element 63A is engaged with the second open end 59A of the vent passage 55A, and an unsealed position (see FIG. 3B) wherein the cone shaped end 65A of the plug element 63A is disengaged from the second open end 59A of the vent passage 55A.

10
15
20
25
30
35
40
[0034] The plug element 63A is linearly movable between the sealed and unsealed positions by actuation of the thumb actuator 46A. The thumb actuator 46A is coupled to the plug element 63A by way of a wire loop element 67A that engages a groove 69A in the plug element 63A. Movement of the thumb actuator 46A between the positions shown in FIGS. 3A and 3B moves the plug element 63A (by way of the wire loop element 67A) between the sealed and unsealed positions. In the sealed position of the plug element 63A, contaminants are prevented from entering the vent passage 55A. In the unsealed position of the plug element 63A (which occurs when the liquid paint component 14 is being dispensed from the original container 16A through the pour spout 40A upon actuation of the thumb actuator 46A), air is allowed to enter the vent passage 55A through the second open end 59A so that the air passes into the interior region 61 A of the original container 16A through the second open end 57A to fill the void of the dispensed liquid paint component 14.

45
50
55
[0035] As seen best in FIGS. 3-8, the second open end 59A of the vent passage 55A is located radially exterior to the cylindrical side wall 71A of the original container 16A. This location of the second open end 59A of the vent passage 55A prevents the liquid paint component 14 from flowing out of the original container 16A through the vent passage 55A and the subsequent fouling of the exterior portions of the lid member 20A. This undesirable condition is prevented because the second open end 59A of the vent passage 55A is located above the fluid level of the liquid paint component 14 in the dispensing state of the liquid paint component illustrated in FIGS. 8 and 11. The vent passage 55A extends substantially perpendicular to and radially from a central axis 73 of the original

container 16A (see FIG. 3A).

[0036] As seen best in FIGS. 3 and 4, the lid member 20A further includes an alignment slot 56A positioned at a first portion of the lid member 20A at the pour spout 40A adjacent to the cover element 44A. As seen in FIGS. 3A and 3B, the alignment slot 56A is positioned so as to define a plane 60 that is parallel to an upper surface 62A of the circumferential lip 24A of the original container 16A. The purpose of the alignment slot 56A will become clear below. The alignment slot 56A is formed integrally with the base portion 26A of the lid member 20A.

[0037] As seen best in FIGS. 3A and 3B, the lid member 20A further includes a stirring device 68A for stirring the liquid paint component 14 within the original container 16A. The stirring device 68A includes a plurality of paddles 70A connected to a paddle actuator 72A by way of a shaft member 74A. Rotating the paddle actuator 72A, as represented by double headed directional arrow 76, causes rotation of the paddles 70A and stirring of the liquid paint component 14. The paddle actuator 72A is driven (i.e., rotated) by a stirring mechanism (not shown) that is part of a storage rack (not shown) for holding various original containers 16A of liquid paint components 14.

[0038] As seen best in FIGS. 1 and 2, the dispensing apparatus 12 of the dispensing system 10 includes a support frame 80. As seen best in FIGS. 2 and 6, the dispensing apparatus 12 further includes a receiving mechanism 98 for releasably engaging the original container 16A, 16B of the liquid paint component 14. The receiving mechanism 98 is defined by first and second engaging mechanisms 100 and 102, respectively.

[0039] As seen best in FIG. 2, the first engaging mechanism 100 includes first and second spaced arms 104a and 104b rigidly mounted to the support frame so as to be fixed against movement relative thereto. A registration rod 108 rigidly connects together the first and second arms 104a and 104b at their free ends 110a and 110b. The registration rod 108 is adapted to releasably receive (i.e., engage) the alignment slot 56A of the lid member 20A. As seen in FIG. 6, interengagement of the alignment slot 56A with the registration rod 108 mounts (i.e., secures) and aligns a first portion of the container 16A and lid member 20A combination to the receiving mechanism 98 of the dispensing apparatus 12.

[0040] The second engaging mechanism 102 includes first and second spaced plates 111a and 111b fixed to an upper end of the support frame 80. Free ends 113a and 113b of the plates 111a, 111b include latch slots 115a and 115b, respectively. The second engaging mechanism 102 further includes first and second spaced L-shaped arms 114a and 114b pivotally mounted to the support frame 80 via a pivot pin 116. A handle member 118 rigidly connects together the first and second L-shaped arms 114a and 114b at their first ends 120a and 120b. Second ends 122a and 122b of the first and second L-shaped arms 114a and 114b include latching notches 124a and 124b. The latching notches 124a and 124b are

adapted to releasably receive (i.e., engage) the latch lugs 43A on the handle 38A of the lid member 20A for the original container 16A to secure the latch lugs 43A in the latch slots 115a and 115b of the plates 111a, 111b. The L-shaped arms 114a and 114b of the second engaging mechanism 102 are pivotally movable as a unit, as represented by double headed arrow 125, between an unlatched state, wherein the original container 16A of the liquid paint component 14 can be engaged with and disengaged from the first and second engaging mechanisms 100 and 102 (shown in FIG. 6); and a latched state, wherein the original container 16A is securely held between the first and second engaging mechanisms 100 and 102 (shown in FIG. 7). As such the L-shaped arms 114a and 114b (i.e., the second engaging mechanism 102) exhibits only a single-degree-of-freedom of movement (i.e., pivotal movement only) relative to the support frame 80 and the first engaging mechanism 100 (i.e., the first and second spaced arms 104a and 104b). A tension spring element 126 is coupled between a mounting peg 128 of the support frame 80 and a mounting peg 129 of an extension arm 130 on the L-shaped arm 114a. The tension spring element 126 biases the L-shaped arms 114a and 114b defining a portion of the second engaging mechanism 102 to the latched state against the stop 133. A handle/stop member 134 limits movement of the L-shaped arms 114a and 114b in a clockwise direction as viewed in FIG. 6.

[0041] As seen best in FIGS. 2 and 6, the dispensing apparatus 12 of the dispensing system 10 further includes dispensing mechanism 140 mounted to the support frame 80 for moving the cover element 44A of the lid member 20A between its closed and open states. The dispensing mechanism 140 includes outwardly extending, first and second arms 142a and 142b that define an operating device 141 pivotally movable, as a unit, as represented by double headed directional arrow 143 (FIG. 8), relative to the support frame 80 about an axle 145. The free ends 146a and 146b, of the first and second arms 142a and 142b, include a force applying mechanism 147 (seen best in FIGS. 9-10) adapted to releasably engage the slot 49A in the cover element 44A on the lid member 20A (see FIGS. 6-10). The force applying mechanism 147 includes U-shaped wire member 149 having legs 151 and a connecting portion 153. The legs 151 are rigidly mounted to the operating device 141. As seen best in FIGS. 9 and 10, the connecting portion 153 is releasably received within the slot 49A of the cover element 44A. The force applying mechanism 147 further includes a force applying plate member 155 that is linearly movable relative to the U-shaped wire member 149 as represented by double headed arrow 330. The force applying plate member 155 includes apertures 157 that freely receive the legs 151 of the U-shaped wire member 149 to permit movement of the plate member 155 along the legs 151. A compression spring 159 surrounds each of the legs 151 and acts between the operating device 141 and the plate member 155 to provide a biasing force urg-

es the plate member 155 against the cover element 44A to prevent inadvertent leakage of the liquid paint component 14 from the pour spout 40A of the lid member 20 atop the original container 16A when the original container 16A is mounted in the dispensing system 10 (see FIG. 7) and the cover element 44A is in a closed position.

[0042] As seen in FIG. 8, with the connecting portion 153 of the force applying mechanism 147 of the operating device 141 engaged with the slot 49A of the cover element 44A, a transit mechanism 150 of the dispensing mechanism 140 can pivotally move the operating device 141 between a first position and a second position. In the first position of the operating device 141 (FIG. 7), the cover element 44A of the lid member 20A is in its closed state which prevents the liquid paint component 14 from being dispensed from the original container 16A with the help of the force applying mechanism 147. In the second position of the operating device 141 (FIG. 8), the cover element 44A is in its opened state which allows the liquid paint component 14 to be dispensed (i.e., poured) from the original container 16A into a paint receptacle 152 (FIG. 1).

[0043] As set forth previously, the handles 38A and 38B of each of the lid members 20A and 20B include the latch lugs 43A, 43B. The difference in positioning of these latch lugs 43A and 43B between the quart size lid member 20A and the gallon size lid member 20B results in the latch lugs 43A, 43B being the same position relative to the alignment slot 56A, 56B. This allows the receiving mechanism 98 (defined by the first and second engaging mechanisms 100 and 102) and the dispensing mechanism 140 to accommodate quart size original containers 16A (FIGS. 6-8) and gallon size original containers 16B (FIG. 11).

[0044] As seen best in FIGS. 6, the transit mechanism 150 of the dispensing mechanism 140 includes a piston member 154 linearly movable, along directional arrow 143 (FIG. 6), relative to a cylinder member 156. Opposite ends 253a and 253b of the first and second arms 142a and 142b (defining the operating device 141) are coupled to the piston member 154. A pad member 158 of the piston member rides on a roller member 259 rotatably mounted to the arms 142a, 142b. Therefore movement of the piston member 154 within the cylinder member 156 causes the operating device 141 to move between its first and second positions. Tension spring elements 160 are coupled between the opposite ends 253a, 253b of the arms 142a, 142b and a mounting member 162 on the support frame 80. The tension springs 160 bias the operating device 141 to its first position (also known as the primary position of the piston member 154).

[0045] As seen in FIG. 1, a drive mechanism 170 of the transit mechanism 150 moves the piston member 154 relative to the cylinder member 156. The drive mechanism 170 includes a piston member 172 linearly movable, along double headed directional arrow 173, relative to a cylinder member 174 mounted to a frame 176 via bracket structure 177. A drive motor, such as a stepper

motor 178, is also mounted to the frame 176. The drive motor 178 includes a drive screw 179 that is telescopically received within a drive tube 180 that is secured at one end to the piston member 172. The drive tube 180 is slidably received within a bearing 181 of the frame 176 to allow movement of the drive tube 180, and the piston member 172 therewith, relative to the frame 176, drive motor 178 and cylinder member 174. An opposite end of the drive tube 180 includes a drive nut 183 that threadably receives the drive screw 179 of the stepper motor 178. Operation of the stepper motor 178 turns the drive screw 179 within the drive nut 183. This in turn moves the drive tube 180 and therewith the piston member 172 within the cylinder member 174 along directional arrow 173. A fluid reservoir 182 containing a hydraulic fluid 184 is in fluid communication with the cylinder member 174. A fluid line 188 couples the fluid reservoir 182 to the cylinder member 156. In operation, movement of the piston member 172, via the stepper motor 178, forces hydraulic fluid 184 to move to and from the cylinder member 174 and the fluid reservoir 182 through the line 188 then into and out of the cylinder member 156 to move the piston member 154. Movement of the piston member 154, via the above described hydraulic fluid pressure, in turn moves the operating device 141 which in turn moves the cover element 44A of the lid member 20A between its opened and closed states.

[0046] As seen in FIGS. 12 and 13, the dispensing system 10 includes an automatic bleeder valve 300 to aid in initially filling the dispensing system 10 with hydraulic fluid 184. The hydraulic bleeder valve 300 includes a body member 302 defining an orifice 304 that extends through the body member 302 from a first end 306 to a second end 308. The orifice 304 is in fluid communication with the fluid line 188 and the cylinder member 156. A linearly movable ball valve 310 is positioned at the first end 306 of the body member 302. The ball valve 310 is movable between a first position, wherein the ball valve 310 forms a fluid seal and air/hydraulic fluid 184 is prevented from passing into the orifice 304 (see FIG. 12), and a second position wherein the ball valve 310 acts as a check valve and air and/or hydraulic fluid 184 may pass through the orifice 304 from the first end 306 to the second end 308 (see FIG. 13). The body member 302 threadably engages the support frame 80 via threads 307 so as to be movable linearly relative thereto. The body member 302 includes a nut 314 at the second end 308 used to twist the body member 302 to move the body member 302 relative to the support frame 80. Near the first end 306, the body member 302 includes an O-ring seal member 312 to prevent air/hydraulic fluid 184 from flowing past the body member 302 through the threads 307. An inner end 316 of the body member 302 bears against a compression spring 318 that in turn bears against the ball valve 310.

[0047] In operation, to fill the cylinder member 156 with hydraulic fluid 184, the body member 302 is loosened using the nut 314 which decompresses the spring 318

and allows the ball valve 310 to move to the position shown in FIG. 13. Hydraulic fluid 184 is then pumped through the fluid line 188 from the reservoir 182 via the piston member 172 of the drive mechanism 170. The hydraulic fluid 184 passes from the fluid line 188 into the cylinder member 156 primarily due to gravity and because this is the fluid path of least resistance. Air within the fluid line 188 and the cylinder member 156 is automatically bled out (by the introduction of the hydraulic fluid 184) through the automatic bleeder valve 300. The air passes around the ball valve 310, through the spring 318 and through the orifice 304 as represented by the arrows 325 in FIG. 13. The fluid line 188 and cylinder member 156 are full of hydraulic fluid 184 when the hydraulic fluid 184 passes out of the orifice 304. The body member 302 is then tightened using the nut 314 which causes the inner end 316 of the body member 302 to bear against the spring 318 which compresses the spring against the ball valve 310 sealing off the orifice 304 of the bleeder valve 300, thereby completing the filling process (see FIG. 12).

[0048] As seen in FIG. 1, the control apparatus 18 of the dispensing system 10 includes a weigh cell 190 for supporting the paint receptacle 152 and a control module 192. The weigh cell 190 determines the weight of the liquid paint component dispensed (i.e., poured) from the original container 16A into the paint receptacle 152. The control module 192 includes a display monitor device 194 having a display 195, a microprocessor device 196, a data storage device 198 and a user interface device, such as a keyboard 200. The keyboard 200 is coupled to the microprocessor device 196 via a communication line 202. The microprocessor device 196 and the data storage device 198 are linked through a communication line 204. The microprocessor device 196 is linked to the stepper motor 178 and to a sensor 205 for monitoring the position of the drive screw 179 through the communication line 206. The microprocessor device 196 is linked to the display monitor device 194 through communication line 208 and is further linked to the weigh cell 190 via communication line 210. Since the control module 192 (i.e., microprocessor device 196) is linked to the stepper motor 178 and the sensor 205, the control module 192 can control operation of the stepper motor 178, and thereby movement of the piston members 172 and 154, and hence movement of the cover element 44A to dispense the liquid paint component 14 from the original container 16A. In addition, since the control module 192 is further linked to the weigh cell 190, the control module 192 can control the amount (i.e., the weight) of the liquid paint component 14 dispensed from its original container 16A to the paint receptacle 152 (atop the weigh cell 190) based upon data (i.e., information) obtained from the weigh cell 190. Moreover, since the control module 192 (i.e., the data storage device 198) stores the paint formulas, the control module 192 can determine which liquid paint components 14 and the weights of these components needed to duplicate a particular paint formula and

can control the dispensing mechanism 140 in accordance therewith.

[0049] As seen in FIG. 1, the control module 192 and the drive mechanism 170 are positioned in another room such that the communication line 210 and the fluid line 188 pass through a wall 212 so as to provide explosion protection for the dispensing system 10. Alternatively, one or more of the display monitor device 194, the microprocessor device 196, and the keyboard 200 could be located next to the dispensing system 10 provided that these components are explosion protected.

[0050] In operation, to mix a particular paint formula, the operator of the semi-automated dispensing system 10 first accesses the control module 192 through the keyboard 200 to call up the desired paint formula using the microprocessor device 196 the data storage device 198. The paint formula (i.e., the liquid paint components 14) is then displayed on the display 195 of the display monitor device 194. The operator then loads the first container 16A, 16B of the needed liquid paint components into the dispensing apparatus 12.

[0051] As seen in FIG. 6, to mount (i.e., load) an original container 16A of a liquid paint component 14 to the receiving mechanism 98 of the dispensing apparatus 12, the operator of the dispensing system 10 first needs to pivot the second engaging mechanism 102 (defined by the L-shaped arms 114a, 114b) clockwise (as viewed in FIG. 6) from its normal latched state to its unlatched state, against the handle/stop member 134 mounted to the support frame 80. The operator, while gripping both the handle member 118 and the handle /stop member 134 to hold the second engaging mechanism 102 in its unlatched state (against the bias of the spring element 126), then engages the alignment slot 56A of the lid member 20A with the registration rod 108 of the first engaging mechanism 100 (FIG. 6). Next, while still holding the second engaging mechanism 102 in its unlatched state, the operator pivots the container 16A and lid member 20A combination clockwise (as viewed in FIG. 6) until the connecting portion 153 of the force applying mechanism 147 of the operating device 141 is fully seated in the slot 49A of the cover element 44A, and the latch lugs 43A are fully seated in the latch slots 115a, 115b of the plates 111a, 111b. With the alignment slot 56 now fully seated on the registration rod 108, the connecting portion 153 of the operating device 141 fully seated in the slot 49A of the cover element, and the latch lugs 43A fully seated in the latch slots 115a, 115b, the operator pivots the second engaging mechanism 102 counterclockwise to its latched state, so that the latching notches 124a and 124b engage the latch lugs 43A of the lid member 20A securing the original container 16A lid member 20A combination to the receiving mechanism 98 the dispensing apparatus 12. To remove the container 16A for the dispensing apparatus 12, this above described process is simply reversed.

[0052] The operator then starts the dispensing process using the keyboard 200 of the control module 192. Since

the control module 192 (i.e., microprocessor device 196) is linked to the stepper motor 178 and the sensor 205, the control module 192 controls operation of the stepper motor 178, and thereby movement of the piston members 154 and 172, and hence movement of the cover element 44A to dispense (i.e., pour) the liquid paint component 14 from the original container 16A into the paint receptacle 152. The arrangement of the second engaging mechanism 102 and the latch lugs 43A prevents movement of the cover element 44A from inadvertently disengaging the alignment slot 56A from the first registration rod 108. The weight of the liquid paint component 14 dispensed into the paint receptacle 152 is monitored by the control module 192 through the weigh cell 190, thereby ensuring an accurate liquid paint component pour. Once the first liquid paint component 14 is poured, its container 16A, 16B is removed and is replaced with the next paint component container 16A, 16B and so on, until all paint components 14 of the paint formula have been added to the paint receptacle 152, thereby completing the paint formula mixing process.

[0053] This lid member 20A, 20B can be used with the original container 16A, 16B of a liquid paint component 14 and the resilient seal mechanism 354 prevents contaminants from entering the original paint component container 16A, 16B through the pour spout/cover element interface 356. In addition, the resilient seal mechanism 354 of the lid member 20A, 20B prevents undesired leakage of the paint component 14 out of the pour spout 40A and past the cover element 44A in the closed state of the cover element 44A. Unwanted leakage of just four drops of the liquid paint component 14 from pour spout 40A, when the container 16A, 16B is mounted the dispensing system 10, can result in the addition of 0.1 grams of unwanted paint component 14 to the paint receptacle 152 which could require the operator of the dispensing system 10 to re-pour other paint components to compensate for this error. The guide mechanism 470 also helps to prevent undesired leakage of the paint component 14 out of the pour spout 40A, by ensuring that the cover element 44A is accurately aligned with the pour spout 40A and guided during movement of the cover element 44A between the closed and opened states. The securing mechanism 460 ensures that the seal mechanism 354 is properly and securely mounted to the cover element 44A so as to be unaffected by the attributes of the paint component 14.

[0054] In addition, this lid member 20A, 20B is compatible with the semi-automated dispensing system 10, for dispensing liquid paint components 14 from their original containers 16A, 16B that virtually eliminates system operator errors, in particular over pouring errors, that can be costly to a body shop or jobber. The lid member 20A, 20B together with the semi-automated dispensing system 10 is easy to use, and does not require a highly skilled operator, since operator interface with the lid members 20A, 20B and the dispensing system 10 is substantially limited to identifying the desired paint formula, and load-

ing and unloading the proper containers 16A, 16B of the liquid paint components 14 to and from the dispensing apparatus 12. The operator need no longer manually pour the paint components 14 from their containers 16A, 16B. The lid member/dispensing system interface automatically dispenses (i.e., pours) the liquid paint components 14 from their containers 16A, 16B, thereby ensuring a highly accurate, precision liquid paint component pour. Moreover, the vent passage 55A, 55B arrangement prevents liquid paint component from flowing out of the second open end 59A, 59B of the vent passage during dispensing of the paint component from the container 16A, 16B. In addition, the lid members 20A, 20B, of the present invention, together with the paint dispensing system 10, makes efficient use of the operator's time, since the operator is free to perform other duties instead of holding the containers 16A, 16B and performing the task of manually pouring the proper amounts of the liquid paint components 14. This efficiency gain allows the operator to mix a greater number of paint formulas during a work day. Lastly, the paint component lid members 20A, 20B, of the present invention, and the semi-automated dispensing system 10 comply with all regulations and laws, such as being explosion protected, governing the handling and mixing of liquid paint components 14 for the duplication of automotive paint formulas.

[0055] Although the present invention has been described with reference to preferred embodiments, workers skilled in the art will recognize that changes may be made in form and detail without departing from the scope of the invention. For example, although the lid members 20A and 20B and the semi-automated dispensing system 10 have s been described as useable to dispense liquid automotive paint components 14 from their original containers 16A and 16B, lid members and the dispensing system can be used to dispense other pourable components, such as primers, thinners and liquid or powdered chemicals. In particular the lid members 20A and 20B and the dispensing system 10 could be used in laboratory or pharmaceutical organizations to accurately dispense liquid and powdered chemicals according to a desired formula.

45 Claims

1. A lid member (20A, 20B) for an original container (16A, 16B) of a pourable component (14), the lid member being usable with a system (10) for dispensing the pourable component from its original container into a receptacle (152) according to a formula to form a mixture of pourable components, the lid member comprising:

a base portion (26A) adapted to releasably engage an open top (22A) of a side wall (71 A) of the original container of the pourable component;

a pour spout (40A) on the base portion through which the pourable component can be dispensed from its original container;
 a cover element (44A) for the pour spout, the cover element being movably mounted to the base portion such that the cover element is movable between a closed state, wherein the cover element covers the pour spout, and an opened state, wherein the pour spout is uncovered and the pourable component can be dispensed from its original container through the pour spout into the receptacle upon tilting of the original container;

characterised by:

seal means (354) positioned between the pour spout and the movable cover element, the seal means preventing leakage of the pourable component, upon tilting of the original container, out of the pour spout past the cover element in the closed state of the cover element, and guide and securing means (470) on the movable cover element, the guide and securing means engaging and securing the seal means to the cover element, and guiding and aligning the cover element on the pour spout as the cover element is moved between the closed and opened states.

2. The lid member (20A, 20B) of claim 1 wherein the pour spout (40A) is defined by first and second opposed side walls (83A, 85A), the guide and securing means (470) engaging the first and second opposed side walls to guide and align the cover element on the pour spout during movement of the cover element between the closed and opened states.
3. The lid member (20A, 20B) of claim 2 wherein the lid member (20A, 20B) includes first and second spaced guide surfaces (89A, 91 A) adjacent to the pour spout (40A), the guide and securing means (470) engaging the first and second spaced guide surfaces to guide and align the cover element on the pour spout during movement of the cover element between the closed and opened states.
4. The lid member (20A, 20B) of claim 3 wherein the guide and securing means (470) includes first, second, third and fourth protrusions (462), and wherein the first protrusion slidably engages the first guide surface (89A), the second protrusion slidably engages the second guide surface (91 A), the third protrusion slidably engages the first side wall (83A), and the fourth protrusion slidably engages the second side wall (85A).
5. The lid member (20A, 20B) of claim 3 wherein the

seal means (354) is a resilient seal means (450), wherein the pour spout (40A) has a circumferential, planar edge surface (350A), wherein the cover element (44A) has a planar lower surface (352A), and wherein the resilient seal means (450) is mounted to the cover element so as to cover the entire lower surface of the cover element, such that the resilient seal means engages and conforms to the shape of the entire circumferential, planar edge surface of the spout at an engagement interface (356) between the circumferential, planar edge surface of the pour spout and the planar lower surface of the cover element, the resilient seal means (450) including:

a first substrate (452) of a resilient material that engages the planar lower surface of the cover element, and
 a second substrate (454) of a flexible and smooth material that is different from the first substrate and allows the cover element to readily move between the closed and open states, the second substrate engaging the circumferential, planar edge surface of the pour spout.

6. The lid member (20A, 20B) of claim 5 wherein the first substrate (452) is a high density polyethylene closed cell foam, and wherein the second substrate (454) is an ultra high molecular weight polyethylene plastic sheet.
7. The lid member (20A, 20B) of claim 5, and further including:
 means (460) formed integrally with the cover element (44A) for securing the first and second substrates (452, 454) to the cover element, the securing means (460) including:
 the first, second, third and fourth protrusions (462) integral with and extending from the planar lower surface (352A) of the cover element, the first, second, third and fourth protrusions engaging the first and second substrates to secure the substrates to the cover element.
8. The lid member (20A, 20B) of claim 7 wherein the first substrate (452) defines four openings (464), with each of the four openings being engageable by one of the first, second, third and fourth protrusions (462), the first, second, third and fourth protrusions being sized to be closely received within the four openings so as to secure the first substrate to the cover element (44A).
9. The lid member (20A, 20B) of claim 8 wherein the second substrate (454) includes four cup shaped protruding portions (466) engageable by the first,

second, third and fourth protrusions (462), the cup shaped protruding portions being sized so as to closely receive the first, second, third and fourth protrusions to secure the second substrate to the cover element (44A).

10. The lid member (20A, 20B) of claim 9 wherein the four cup shaped protruding portions (462) are adapted to slidably receive the first, second third and fourth protrusions (462) so as to allow the second substrate (454) to move substantially perpendicular relative to the planar lower surface (352A) of the cover element (44A) upon compression and extension of the first substrate (452), allowing the resilient seal means (450) to engage and conform to the shape of the entire circumferential planar edge surface (350A) of the pour spout (40A).

11. The lid member (20A, 20B) of claim 1 wherein the pourable component (14) is a liquid paint component, the receptacle (152) is a paint receptacle, the formula is a paint formula, and the mixture of pourable components is a liquid paint mixture.

12. The lid member (20A, 20B) of claim 1 wherein the cover element (44A) has a planar lower surface (352A), the lid member further comprising:

resilient seal means (450) positioned between the pour spout (40A) and the movable cover element (44A), the resilient seal means preventing leakage of the pourable component (14), upon tilting of the original container (16A, 16B), out of the pour spout past the cover element in the closed state of the cover element, the resilient seal means including:

a first substrate (452) of a first material, and a second substrate (454) of a second material that is different from the first material, and

securing means (460) formed integrally with the cover element for engaging and securing the resilient seal means to the cover element, the securing means including:

at least one protrusion (462) integral with and extending from the planar lower surface of the cover element, the at least one protrusion engaging the first and second substrates to secure the substrates to the cover element.

13. The lid member (20A, 20B) of claim 1 further comprising:

a vent passage (55A) passing through the base

portion of the lid member, the vent passage having a first open end (57A) communicating with an interior region of the original container (16A, 16b) and a second open end (59A) communicating with atmosphere, wherein the second open end of the vent passage is at least exterior to an innermost portion of the original cylindrical container to permit air to pass through the vent passage upon tilting of the original cylindrical container to dispense the pourable component (14) from the pour spout (40A) in the opened state of the cover element (44A).

14. The lid member (20A, 20B) of claim 13 wherein the original container (16A, 16B) has a central axis (73) and wherein the vent passage (55A) extends radially from the central axis, such that the second open end (59A) of the vent passage is above a fluid level of the pourable component (14) upon tilting of the original container to dispense the pourable component from the pour spout (40A) in the opened state of the cover element (44A).

15. The lid member (20A, 20B) of claim 13, and further including:

a plug element (63A) engageable with the vent passage (55A) for sealing the vent passage to prevent contaminants from entering the interior region (61A) of the original container (16A, 16B) through the vent passage.

16. The lid member (20A, 20B) of claim 15 wherein the plug element (63A) is engageable with the second open end (59A) of the vent passage (55A).

17. The lid member (20A, 20B) of claim 16 wherein the plug element (63A) is movably mounted to the base portion (26A) such that the plug element is movable between a sealed position, wherein the plug element is engaged with the second open end (59A) of the vent passage (55A), and an unsealed position, wherein the plug element is disengaged from the second open end of the vent passage.

18. The lid member (20A, 20B) of claim 16 wherein the second open end (59A) of the vent passage (55A) is cone shaped and wherein the plug element has a cone shaped end (65A) for engaging the cone shaped second open end of the vent passage.

19. The lid member (20A, 20B) of claim 13, and further including:

a manually operable actuator (46A) for the cover element (44A), the actuator being coupled to the cover element; and means (48A) for pivotally mounting the actuator

to the base portion (26A), such that manually pivoting the actuator moves the cover element between its closed and opened states.

20. The lid member (20A, 20B) of claim 19, and further including:

a plug element (63A) associated with the actuator (46A), such that pivotal movement of the actuator to move the cover element (44A) between its closed and opened states moves the plug element between a sealed position, wherein the plug element is engaged with the second open end (59A) of the vent passage (55A), and an unsealed position, wherein the plug element is disengaged from the second open end of the vent passage.

21. The lid member (20A, 20B) of claim 19 wherein a wire loop member (50A) couples the cover element (44A) to the actuator (46A).

22. The lid member (20A, 20B) of claim 21 wherein the wire loop member (50A) is defined by a first portion that extends from the actuator (46A) toward the cover element (44A), and a second portion that forms an angle with respect to the first portion, the second portion engaging at least one retaining feature of the cover element.

23. The lid member (20A, 20B) of claim 22 wherein the second portion forms an obtuse angle with respect to the first portion.

24. The lid member (20A, 20B) of claim 1 further comprising:

a movable manually operable actuator (46A) for the cover element (44A); and
a wire loop member (50A) coupling the cover element to the actuator, the wire loop member being defined by a first portion that extends from the actuator toward the cover element, and a second portion that forms an angle with respect to the first portion, the second portion engaging at least one retaining feature of the cover element.

25. The lid member (20A, 20B) of claim 24 wherein the second portion forms an obtuse angle with respect to the first portion.

26. The lid member (20A, 20B) of claim 24 wherein the angled second portion of the wire loop (50A) applies a force against the cover element (44A) to aid in sealing an interface (356) between the cover element and the pour spout (40A) in the closed state of the cover element.

Patentansprüche

1. Deckelement (20A, 20B) für einen Originalbehälter (16A, 16B) einer gießfähigen Komponente (14), wobei das Deckelement mit einem System (10) zur Abgabe der gießfähigen Komponente aus ihrem Originalbehälter in ein Gefäß (152) gemäß einer Formel zum Bilden einer Mischung gießfähiger Komponenten zu verwenden ist, wobei das Deckelement umfaßt:

einen Basisabschnitt (26A), ausgelegt zum lösbaren Eingreifen mit einer offenen Oberkante (22A) einer Seitenwand (71A) des Originalbehälters der gießfähigen Komponente, einen Ausgießstutzen (40A) auf dem Basisabschnitt, durch den die gießfähige Komponente aus ihrem Originalbehälter abgegeben werden kann,

ein Abdeckelement (44A) für den Ausgießstutzen, wobei das Abdeckelement bewegbar auf dem Basisabschnitt angebracht ist, so daß das Abdeckelement zwischen einem geschlossenen Zustand, in dem das Abdeckelement den Ausgießstutzen bedeckt, und einem geöffneten Zustand, in dem der Ausgießstutzen unbedeckt ist und die gießfähige Komponente durch das Neigen des Originalbehälters aus ihrem Originalbehälter durch den Ausgießstutzen in das Gefäß abgegeben werden kann, bewegbar ist, **gekennzeichnet durch**

zwischen dem Ausgießstutzen und dem bewegbaren Abdeckelement positionierte Dichtungsmittel (354), die das Durchlecken der gießfähigen Komponente beim Neigen des Originalbehälters am Abdeckelement vorbei in dessen geschlossenem Zustand **durch** den Ausgießstutzen verhindern, und

Führungs- und Sicherungsmittel (470) auf dem bewegbaren Abdeckelement, wobei die Führungs- und Sicherungsmittel die Dichtungsmittel mit dem Abdeckelement in Eingriff bringen und an diesem befestigen und das Abdeckelement auf dem Ausgießstutzen führen und ausrichten, wenn das Abdeckelement zwischen dem geschlossenen und dem geöffneten Zustand bewegt wird.

2. Deckelement (20A, 20B) nach Anspruch 1, wobei der Ausgießstutzen (40A) durch erste und zweite einander gegenüberliegende Seitenwände (83A, 85A) definiert ist, wobei die Führungs- und Sicherungsmittel (470) in die ersten und zweiten einander gegenüberliegenden Seitenwände eingreifen, um das Abdeckelement auf dem Ausgießstutzen während der Bewegung des Abdecklements zwischen dem geöffneten und dem geschlossenen Zustand zu führen und auszurichten.

3. Deckelelement (20A, 20B) nach Anspruch 2, wobei das Deckelelement (20A, 20B) an dem Ausgießstutzen (40A) angrenzende erste und zweite in einem Abstand voneinander angeordnete Führungsflächen (89A, 91A) enthält, wobei die Führungs- und Sicherungsmittel (417) in die ersten und zweiten in einem Abstand voneinander angeordneten Führungsflächen eingreifen, um das Abdeckelement auf dem Ausgießstutzen während der Bewegung des Abdeckelements zwischen dem geschlossenen und dem geöffneten Zustand zu führen und auszurichten.
4. Deckelelement (20A, 20B) nach Anspruch 3, wobei die Führungs- und Sicherungsmittel (470) erste, zweite, dritte und vierte Vorsprünge (462) enthalten und wobei der erste Vorsprung gleitend in die erste Führungsfläche (89A), der zweite Vorsprung gleitend in die zweite Führungsfläche (91A), der dritte Vorsprung gleitend in die erste Seitenwand (83A) und der vierte Vorsprung gleitend in die zweite Seitenwand (85A) eingreifen.
5. Deckelelement (20A, 20B) nach Anspruch 3, wobei die Dichtungsmittel (354) federnde Dichtungsmittel (450) sind, wobei der Ausgießstutzen (40A) eine ebene Umfangskantenfläche (350A) aufweist, wobei das Abdeckelement (44A) eine ebene untere Fläche (352A) aufweist und wobei die federnden Dichtungsmittel (450) auf dem Abdeckelement angebracht sind, um so die gesamte untere Fläche des Abdeckelements zu bedecken, so daß die federnden Dichtungsmittel mit der Form der gesamten ebenen Umfangskantenfläche des Stutzens an einer Eingriffsgrenzfläche (356) zwischen der ebenen Umfangskantenfläche des Ausgießstutzens und der ebenen unteren Fläche des Abdeckelements in Eingriff gebracht werden und sich an diese anpassen, wobei die federnden Dichtungsmittel (450) enthalten:
- ein erstes Substrat (452) aus federndem Material, das in die ebene untere Fläche des Abdeckelements eingreift, und
ein zweites Substrat (454) eines flexiblen und glatten Materials, das sich vom ersten Substrat unterscheidet und es dem Abdeckelement erlaubt, sich leicht zwischen dem geschlossenen und dem geöffneten Zustand zu bewegen, wobei das zweite Substrat in die ebene Umfangskantenfläche des Ausgießstutzens eingreift.
6. Deckelelement (20A, 20B) nach Anspruch 5, wobei das erste Substrat (452) ein geschlossenzelliger Hochdruckpolyethylenschaum ist und wobei das zweite Substrat (454) eine Kunststofflage aus Polyethylen mit ultrahohem Molekulargewicht ist.
7. Deckelelement (20A, 20B) nach Anspruch 5, ferner enthaltend:
- eine einstückig mit dem Abdeckelement (44A) gebildete Einrichtung (460) zum Befestigen des ersten und des zweiten Substrats (452, 454) am Abdeckelement, wobei die Befestigungseinrichtung (460) enthält:
- den ersten, den zweiten, den dritten und den vierten Vorsprung (462), der einstückig mit der ebenen unteren Fläche (352A) des Abdeckelements ist und von diesem aus verläuft, wobei der erste, der zweite, der dritte und der vierte Vorsprung in das erste und das zweite Substrat eingreifen, um die Substrate am Abdeckelement zu befestigen.
8. Deckelelement (20A, 20B) nach Anspruch 7, wobei das erste Substrat (452) vier Öffnungen (464) definiert, wobei jede der vier Öffnungen mit einem des ersten, des zweiten, des dritten und des vierten Vorsprungs (462) in Eingriff gebracht werden kann, wobei der erste, der zweite, der dritte und der vierte Vorsprung so dimensioniert sind, daß sie eng innerhalb der vier Öffnungen empfangen werden können, um so das erste Substrat am Abdeckelement (44A) zu befestigen.
9. Deckelelement (20A, 20B) nach Anspruch 8, wobei das zweite Substrat (254) vier tassenförmige vorspringende Abschnitte (462) enthält, die mit dem ersten, dem zweiten, dem dritten und dem vierten Vorsprung (462) in Eingriff gebracht werden können, wobei die tassenförmigen vorspringenden Abschnitte so dimensioniert sind, daß sie den ersten, den zweiten, den dritten und den vierten Vorsprung eng empfangen können, um das zweite Substrat am Abdeckelement (44A) zu befestigen.
10. Deckelelement (20A, 20B) nach Anspruch 9, wobei die vier tassenförmigen vorspringenden Abschnitte (462) so ausgelegt sind, daß sie den ersten, den zweiten, den dritten und den vierten Vorsprung (462) gleitend so empfangen können, daß sie es dem zweiten Substrat (454) erlauben, sich im wesentlichen senkrecht zur ebenen unteren Fläche (352A) des Abdeckelements (44A) bei Verdichtung und Ausdehnung des ersten Substrats (452) zu bewegen, was den federnden Dichtungsmitteln (450) erlaubt, in die Form der gesamten ebenen Umfangskantenfläche (350A) des Ausgießstutzens (40A) einzugreifen und sich an diese anzupassen.
11. Deckelelement (20A, 20B) nach Anspruch 1, wobei die gießfähige Komponente (14) eine flüssige Farbkomponente ist, das Gefäß (152) ein Farbgefäß ist,

die Farbe eine Farbformel ist und die Mischung gießfähiger Komponenten eine flüssige Farbmischung ist.

12. Deckelement (20A, 20B) nach Anspruch 1, wobei das Abdeckelement (44A) eine ebene untere Fläche (352A) aufweist, wobei das Deckelement ferner umfaßt:

zwischen dem Ausgießstutzen (40A) und dem bewegbaren Dichtelement (44A) positionierte federnde Dichtungsmittel (450), wobei die federnden Dichtungsmittel das Durchlecken der gießfähigen Komponente (14) beim Neigen des Originalbehälters (16A, 16B) am Abdeckelement vorbei aus dem Ausgießstutzen im geschlossenen Zustand des Abdeckelements verhindern, wobei die federnden Dichtungsmittel enthalten:

ein erstes Substrat (452) aus einem ersten Material und

ein zweites Substrat (454) eines zweiten Materials, das sich vom ersten Material unterscheidet, und

eine einstückig mit dem Abdeckelement ausgebildete Befestigungseinrichtung (460) zum Ineingriffbringen und Befestigen der federnden Dichtungsmittel am Abdeckelement, wobei die Befestigungseinrichtung enthält:

mindestens einen Vorsprung (462), der einstückig mit der ebenen unteren Fläche des Abdeckelements ist und von dieser aus verläuft, wobei der mindestens eine Vorsprung in das erste und zweite Substrat eingreift, um die Substrate am Abdeckelement zu befestigen.

13. Deckelement (20A, 20B) nach Anspruch 1, ferner umfassend:

einen Lüftungsdurchgang (55A), der durch den Basisabschnitt des Deckelements verläuft, wobei der Lüftungsdurchgang ein erstes offenes Ende (57A), das mit einem inneren Bereich des Originalbehälters (16A, 16B) kommuniziert, und ein zweites offenes Ende (59A), das mit der Atmosphäre kommuniziert, aufweist, wobei das zweite offene Ende des Lüftungsdurchgangs zumindest außerhalb eines innersten Abschnitts des zylindrischen Originalbehälters ist, um den Luftdurchzug durch den Lüftungsdurchgang beim Neigen des zylindrischen Originalbehälters zur Abgabe der gießfähigen Komponente (14) aus dem Ausgießstutzen (40A) im

geöffneten Zustand des Abdeckelements (44A) zu erlauben.

14. Deckelement (20A, 20B) nach Anspruch 13, wobei der Originalbehälter (16A, 16B) eine Mittelachse (73) aufweist und wobei der Lüftungsdurchgang (55A) radial von der Mittelachse aus verläuft, so daß das zweite offene Ende (59A) des Lüftungsdurchgangs oberhalb eines Flüssigkeitsspiegels der gießfähigen Komponente (14) beim Neigen des Originalbehälters zur Abgabe der gießfähigen Komponente aus dem Ausgießstutzen (40A) im geöffneten Zustand des Abdeckelements (44A) liegt.

15. Deckelement (20A, 20B) nach Anspruch 13, ferner enthaltend:

ein Steckerelement (63A), das mit dem Lüftungsdurchgang (55A) zum Abdichten des Lüftungsdurchgangs in Eingriff gebracht werden kann, um Kontaminationen daran zu verhindern, durch den Lüftungsdurchgang in den inneren Bereich (61A) des Originalbehälters (16A, 16B) einzutreten.

16. Deckelement (20A, 20B) nach Anspruch 15, wobei das Steckerelement (63A) mit dem zweiten offenen Ende (59A) des Lüftungsdurchgangs (55A) in Eingriff gebracht werden kann.

17. Deckelement (20A, 20B) nach Anspruch 16, wobei das Steckerelement (63A) bewegbar am Basisabschnitt (26A) angebracht ist, so daß das Steckerelement zwischen einer Dichtungsposition, in der das Steckerelement in das zweite offene Ende (59A) des Lüftungsdurchgangs (55A) eingreift, und einer undichteten Position, in der das Steckerelement aus dem zweiten offenen Ende des Lüftungsdurchgangs abgelöst ist, bewegbar ist.

18. Deckelement (20A, 20B) nach Anspruch 16, wobei das zweite offene Ende (59A) des Lüftungsdurchgangs (55A) kegelförmig ist und wobei das Steckerelement ein kegelförmiges Ende (65A) zum Eingreifen in das kegelförmige zweite offene Ende des Lüftungsdurchgangs aufweist.

19. Deckelement (20A, 20B) nach Anspruch 13, ferner enthaltend

ein handbedienbares Stellglied (46A) für das Abdeckelement (44A), wobei das Stellglied mit dem Abdeckelement verbunden ist, und eine Einrichtung (48A) zum drehbaren Anbringen des Stellglieds am Basisabschnitt (26A), so daß das Drehen des Stellglieds per Hand das Abdeckelement zwischen seinem geschlossenen und seinem geöffneten Zustand bewegt.

20. Deckelelement (20A, 20B) nach Anspruch 19, ferner enthaltend

ein zum Stellglied (46A) gehörendes Stecker-
element, so daß Drehbewegungen des Stell-
glieds zum Bewegen des Abdeckelements
(44A) zwischen seinem geschlossenen und sei-
nem geöffneten Zustand das Stecker-
element zwischen einer Dichtungsposition, in der das
Stecker-
element in das zweite offene Ende (59A)
des Lüftungsdurchgangs (55A) eingreift, und einer
ungedichteten Stellung, in der das Stecker-
element aus dem zweiten offenen Ende des Lüf-
tungsdurchgangs abgelöst ist, bewegen.

21. Deckelelement (20A, 20B) nach Anspruch 19, wobei ein Drahtschleifenelement (50A) das Abdeckele-
ment (44A) mit dem Stellglied (46A) verbindet.

22. Deckelelement (20A, 20B) nach Anspruch 21, wobei das Drahtschleifenelement (50A) durch einen ersten
Abschnitt, der vom Stellglied (46A) zum Abdeckele-
ment (44A) hin verläuft, und einen zweiten Abschnitt,
der einen Winkel bezüglich des ersten Abschnitts
bildet, definiert ist, wobei der zweite Abschnitt in we-
nigstens eine Rückhalteausprägung des Abdeckele-
ments eingreift.

23. Deckelelement (20A, 20B) nach Anspruch 22, wobei der zweite Abschnitt bezüglich des ersten Abschnitts
einen stumpfen Winkel bildet.

24. Deckelelement (20A, 20B) nach Anspruch 1, ferner umfassend

ein bewegbares handbedienbares Stellglied
(46A) für das Abdeckelelement (44A) und
ein Drahtschleifenelement (50A), das das Ab-
deckelelement mit dem Stellglied verbindet, wo-
bei das Drahtschleifenelement durch einen er-
sten Abschnitt, der vom Stellglied aus zum Ab-
deckelelement hin verläuft und einen zweiten Ab-
schnitt, der einen Winkel bezüglich des ersten
Abschnitts bildet, definiert ist, wobei der zweite
Abschnitt in mindestens eine Rückhalteausprä-
gung des Abdeckelements eingreift.

25. Deckelelement (20A, 20B) nach Anspruch 24, wobei der zweite Abschnitt bezüglich des ersten Abschnitts
einen stumpfen Winkel bildet.

26. Deckelelement (20A, 20B) nach Anspruch 24, wobei der in einem Winkel angeordnete zweite Abschnitt
der Drahtschleife (50A) eine Kraft gegen das Abdek-
element (44A) aufbringt, um das Abdichten einer
Grenzfläche (356) zwischen dem Abdeckelelement
und dem Ausgießstutzen (40A) im geschlossenen
Zustand des Abdeckelements zu unterstützen.

Revendications

1. Élément de recouvrement (20A, 20B) destiné à un
récipient d'origine (16A, 16B) d'un composant pou-
vant s'écouler (14), l'élément de recouvrement pou-
vant être utilisé avec un système (10) destiné à dis-
tribuer le composant pouvant s'écouler depuis son
récipient d'origine dans un réceptacle (152) confor-
mément à une formule pour former un mélange de
composants pouvant s'écouler, l'élément de couver-
cle comprenant :

une partie de base (26A) conçue pour s'engager
de façon amovible avec une partie supérieure
ouverte (22A) d'une paroi latérale (71A) du réci-
pient d'origine du composant pouvant s'écou-
ler,
un bec verseur (40A) sur la partie de base à
travers lequel le composant pouvant s'écouler
peut être distribué depuis son récipient d'origi-
ne,
un élément de couvercle (44A) destiné au bec
verseur, l'élément de couvercle étant monté
avec possibilité de déplacement sur la partie de
base de telle sorte que l'élément de couvercle
peut se déplacer entre un état fermé, où l'élé-
ment de couvercle couvre le bec verseur, et un
état ouvert, où le bec verseur est découvert et
le composant pouvant s'écouler peut être distri-
bué depuis son récipient d'origine à travers le
bec verseur dans le réceptacle lors de l'inclina-
ison du récipient d'origine,

caractérisé par :

un moyen d'étanchéité (354) positionné entre le
bec verseur et l'élément de couvercle mobile, le
moyen d'étanchéité empêchant une fuite du
composant pouvant s'écouler, lors de l'inclina-
ison du récipient d'origine, hors du bec verseur
au-delà de l'élément de couvercle dans l'état fer-
mé de l'élément de couvercle, et
un moyen de guidage et de fixation (470) sur
l'élément de couvercle mobile, le moyen de gui-
dage et de fixation engageant et fixant le moyen
d'étanchéité sur l'élément de couvercle, et gui-
dant et alignant l'élément de couvercle sur le
bec verseur lorsque l'élément de couvercle est
déplacé entre les états fermé et ouvert.

2. Élément de recouvrement (20A, 20B) selon la reven-
dication 1, dans lequel le bec verseur (40A) est défini
par des première et deuxième parois latérales op-
posées (83A, 85A), le moyen de guidage et de fixa-
tion (470) s'engageant avec les première et deuxiè-
me parois latérales opposées pour guider et aligner
l'élément de couvercle sur le bec verseur au cours
d'un déplacement de l'élément de couvercle entre

les états fermé et ouvert.

3. Elément de recouvrement (20A, 20B) selon la revendication 2, où l'élément de recouvrement (20A, 20B) comprend des première et deuxième surfaces de guidage écartées (89A, 91A) adjacentes au bec verseur (40A), le moyen de guidage et de fixation (470) s'engageant avec les première et deuxième surfaces de guidage écartées pour guider et aligner l'élément de couvercle sur le bec verseur au cours d'un déplacement de l'élément de couvercle entre les états fermé et ouvert.

4. Elément de recouvrement (20A, 20B) selon la revendication 3, dans lequel le moyen de guidage et de fixation (470) comprend des première, deuxième, troisième et quatrième protubérances (462), et dans lequel la première protubérance s'engage avec possibilité de coulissement avec la première surface de guidage (89A), la deuxième protubérance s'engage avec possibilité de coulissement avec la deuxième surface de guidage (91A), la troisième protubérance s'engage avec possibilité de coulissement avec la première paroi latérale (83A) et la quatrième protubérance s'engage avec possibilité de coulissement avec la deuxième paroi latérale (85A).

5. Elément de recouvrement (20A, 20B) selon la revendication 3, dans lequel le moyen d'étanchéité (354) est un moyen d'étanchéité élastique (450) où le bec verseur (40A) présente une surface de bord circonferentielle plane (350A), où l'élément de couvercle (44A) présente une surface inférieure plane (352A), et où le moyen d'étanchéité élastique (450) est monté sur l'élément de couvercle de façon à recouvrir la totalité de la surface inférieure de l'élément de couvercle, de telle sorte que le moyen d'étanchéité élastique s'engage avec et se conforme à la forme de la totalité de la surface de bord circonferentielle plane du bec au niveau d'une interface d'engagement (356) entre la surface de bord circonferentielle plane du bec verseur et la surface inférieure plane de l'élément de couvercle, le moyen d'étanchéité élastique (450) comprenant :

un premier substrat (452) constitué d'un matériau élastique qui s'engage avec la surface inférieure plane de l'élément de couvercle, et un deuxième substrat (454) constitué d'un matériau souple et lisse qui est différent du premier substrat et permet à l'élément de couvercle de se déplacer facilement entre les états fermé et ouvert, le deuxième substrat s'engageant avec la surface de bord circonferentielle plane du bec verseur.

6. Elément de recouvrement (20A, 20B) selon la revendication 5, dans lequel le premier substrat (452) est

une mousse à cellules fermées de polyéthylène à haute densité, et dans lequel le deuxième substrat (454) est une feuille en matière plastique de polyéthylène à masse moléculaire ultra élevée.

7. Elément de recouvrement (20A, 20B) selon la revendication 5, et comprenant en outre :

un moyen (460) formé de façon solidaire de l'élément de couvercle (44A) destiné à fixer les premier et deuxième substrats (452, 454) à l'élément de couvercle, le moyen de fixation (460) comprenant :

les première, deuxième, troisième et quatrième protubérances (462) intégrées à la surface inférieure plane (352A) de l'élément de couvercle, et s'étendant à partir de celle-ci, les première, deuxième, troisième et quatrième protubérances s'engageant avec les premier et deuxième substrats pour fixer les substrats à l'élément de couvercle.

8. Elément de recouvrement (20A, 20B) selon la revendication 7, dans lequel le premier substrat (452) définit quatre ouvertures (464), chacune des quatre ouvertures pouvant recevoir une des première, deuxième, troisième et quatrième protubérances (462), les première, deuxième, troisième et quatrième protubérances étant dimensionnées pour être reçues de façon rapprochée à l'intérieur des quatre ouvertures de façon à fixer le premier substrat à l'élément de couvercle (44A).

9. Elément de recouvrement (20A, 20B) selon la revendication 8, dans lequel le deuxième substrat (454) comprend quatre parties dépassant en forme de coupe (466) pouvant être engagées avec les première, deuxième, troisième et quatrième protubérances (462), les parties dépassant en forme de coupe étant dimensionnées afin de recevoir de façon rapprochée les première, deuxième, troisième et quatrième protubérances pour fixer le deuxième substrat à l'élément de couvercle (44A).

10. Elément de recouvrement (20A, 20B) selon la revendication 9, dans lequel les quatre parties dépassant en forme de coupe (466) sont conçues pour recevoir avec possibilité de coulissement les première, deuxième, troisième et quatrième protubérances (462) de façon à permettre au deuxième substrat (454) de se déplacer globalement perpendiculairement par rapport à la surface inférieure plane (352A) de l'élément de couvercle (44A) lors d'une compression et d'une extension du premier substrat (452), en permettant au moyen d'étanchéité élastique (450) de s'engager avec et de se conformer à la for-

me de la totalité de la surface de bord circonférentielle plane (350A) du bec verseur (40A).

11. Elément de recouvrement (20A, 20B) selon la revendication 1, dans lequel le composant pouvant s'écouler (14) est un composant de peinture liquide, le réceptacle (152) est un réceptacle de peinture, la formule est une formule de peinture, et le mélange de composants pouvant s'écouler est un mélange de peintures liquides.

12. Elément de recouvrement (20A, 20B) selon la revendication 1, dans lequel l'élément de couvercle (44A) présente une surface inférieure plane (352A), l'élément de recouvrement comprenant en outre :

un moyen d'étanchéité élastique (450) positionné entre le bec verseur (40A) et l'élément de couvercle mobile (44A), le moyen d'étanchéité élastique empêchant une fuite du composant pouvant s'écouler (14), lors d'une inclinaison du récipient d'origine (16A, 16B), hors du bec verseur au-delà de l'élément de couvercle dans l'état fermé de l'élément de couvercle, le moyen d'étanchéité élastique comprenant :

un premier substrat (452) d'un premier matériau, et

un deuxième substrat (454) d'un deuxième matériau qui est différent du premier matériau, et

un moyen de fixation (460) formé de façon solidaire de l'élément de couvercle pour engager et fixer le moyen d'étanchéité élastique sur l'élément de couvercle, le moyen de fixation comprenant :

au moins une protubérance (462) intégrée à la surface inférieure plane de l'élément de couvercle, et s'étendant à partir de celle-ci, l'au moins une protubérance s'engageant avec les premier et deuxième substrats pour fixer les substrats à l'élément de couvercle.

13. Elément de recouvrement (20A, 20B) selon la revendication 1, comprenant en outre :

un passage d'évent (55A) traversant la partie de base de l'élément de recouvrement, le passage d'évent présentant une première extrémité ouverte (57A) communiquant avec une région intérieure du récipient d'origine (16A, 16B) et une deuxième extrémité ouverte (59A) communiquant avec l'atmosphère, où la deuxième extrémité ouverte du passage d'évent est au moins extérieure par rapport à une partie la plus intérieure du récipient cylindrique d'origine pour per-

mettre à de l'air de traverser le passage d'évent lors de l'inclinaison du récipient cylindrique d'origine pour distribuer le composant pouvant s'écouler (14) à partir du bec verseur (40A) dans l'état ouvert de l'élément de couvercle (44A).

14. Elément de recouvrement (20A, 20B) selon la revendication 13, dans lequel le récipient d'origine (16A, 16B) présente un axe central (73), et dans lequel le passage d'évent (55A) s'étend radialement depuis l'axe central, de telle sorte que la deuxième extrémité ouverte (59A) du passage d'évent est au-dessus d'un niveau de fluide du composant pouvant s'écouler (14) lors de l'inclinaison du récipient d'origine pour distribuer le composant pouvant s'écouler à partir du bec verseur (40A) dans l'état ouvert de l'élément de couvercle (44A).

15. Elément de recouvrement (20A, 20B) selon la revendication 13, et comprenant en outre :

un élément de bouchon (63A) pouvant être introduit dans le passage d'évent (55A) pour sceller le passage d'évent afin d'empêcher des contaminants d'entrer dans la région intérieure (61A) du récipient d'origine (16A, 16B) à travers le passage d'évent.

16. Elément de recouvrement (20A, 20B) selon la revendication 15, dans lequel l'élément de bouchon (63A) peut s'engager dans la deuxième extrémité ouverte (59A) du passage d'évent (55A).

17. Elément de recouvrement (20A, 20B) selon la revendication 16, dans lequel l'élément de bouchon (63A) est monté de façon mobile sur la partie de base (26A) de telle sorte que l'élément de bouchon peut être déplacé entre une position scellée, où l'élément de bouchon est engagé dans la deuxième extrémité ouverte (59A) du passage d'évent (55A), et une position non scellée, où l'élément de bouchon est désengagé de la deuxième extrémité ouverte du passage d'évent.

18. Elément de recouvrement (20A, 20B) selon la revendication 16, dans lequel la deuxième extrémité ouverte (59A) du passage d'évent (55A) est de forme conique, et dans lequel l'élément de bouchon présente une extrémité de forme conique (65A) destinée à s'engager avec la deuxième extrémité ouverte de forme conique du passage d'évent.

19. Elément de recouvrement (20A, 20B) selon la revendication 13, et comprenant en outre :

un actionneur pouvant être actionné manuellement (46A) destiné à l'élément de couvercle (44A), l'actionneur étant couplé à l'élément de

- couvercle, et
un moyen (48A) destiné à monter de façon pivotante l'actionneur sur la partie de base (26A), de telle sorte que l'actionneur pivotant de façon manuelle déplace l'élément de couvercle entre ses états fermé et ouvert. 5
- 20.** Elément de recouvrement (20A, 20B) selon la revendication 19, et comprenant en outre : 10
- un élément de bouchon (63A) associé à l'actionneur (46A) de telle sorte qu'un mouvement de pivotement de l'actionneur pour déplacer l'élément de couvercle (44A) entre ses états fermé et ouvert déplace l'élément de bouchon entre une position scellée, où l'élément de bouchon est introduit dans la deuxième extrémité ouverte (59A) du passage d'évent (55A), et une position non scellée, où l'élément de bouchon est désengagé de la deuxième extrémité ouverte du passage d'évent. 15
20
- 21.** Elément de recouvrement (20A, 20B) selon la revendication 19, dans lequel un élément de boucle de fil (50A) couple l'élément de couvercle (44A) à l'actionneur (46A). 25
- 22.** Elément de recouvrement (20A, 20B) selon la revendication 21, dans lequel l'élément de boucle de fil (50A) est défini par une première partie qui s'étend depuis l'actionneur (46A) vers l'élément de couvercle (44A), et une deuxième partie qui forme un angle par rapport à la première partie, la deuxième partie s'engageant avec au moins un élément de maintien de l'élément de couvercle. 30
35
- 23.** Elément de recouvrement (20A, 20B) selon la revendication 22, dans lequel la deuxième partie forme un angle obtus par rapport à la première partie. 40
- 24.** Elément de recouvrement (20A, 20B) selon la revendication 1, comprenant en outre : 45
- un actionneur mobile pouvant être actionné manuellement (46A) destiné à l'élément de couvercle (44A), et 45
un élément de boucle de fil (50A) couplant l'élément de couvercle à l'actionneur, l'élément de boucle de fil étant défini par une première partie qui s'étend depuis l'actionneur vers l'élément de couvercle, et une deuxième partie qui forme un angle par rapport à la première partie, la deuxième partie s'engageant avec au moins un élément de maintien de l'élément de couvercle. 50
55
- 25.** Elément de recouvrement (20A, 20B) selon la revendication 24, dans lequel la deuxième partie forme un angle obtus par rapport à la première partie.
- 26.** Elément de recouvrement (20A, 20B) selon la revendication 24, dans lequel la deuxième partie inclinée de la boucle de fil (50A) applique une force contre l'élément de couvercle (44A) pour contribuer au scellement d'une interface (356) entre l'élément de couvercle et le bec verseur (40A) dans l'état fermé de l'élément de couvercle.

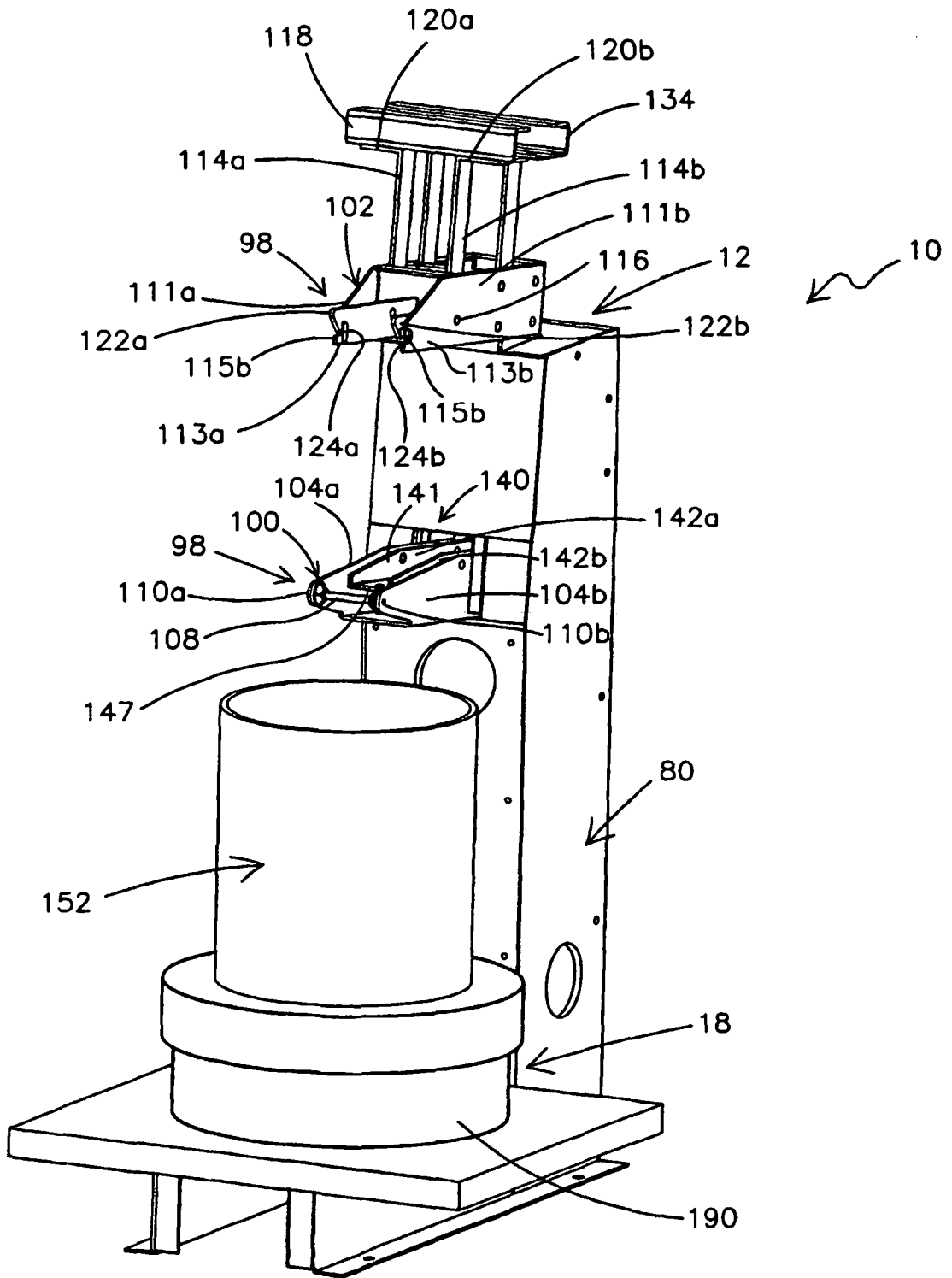

Fig. 2

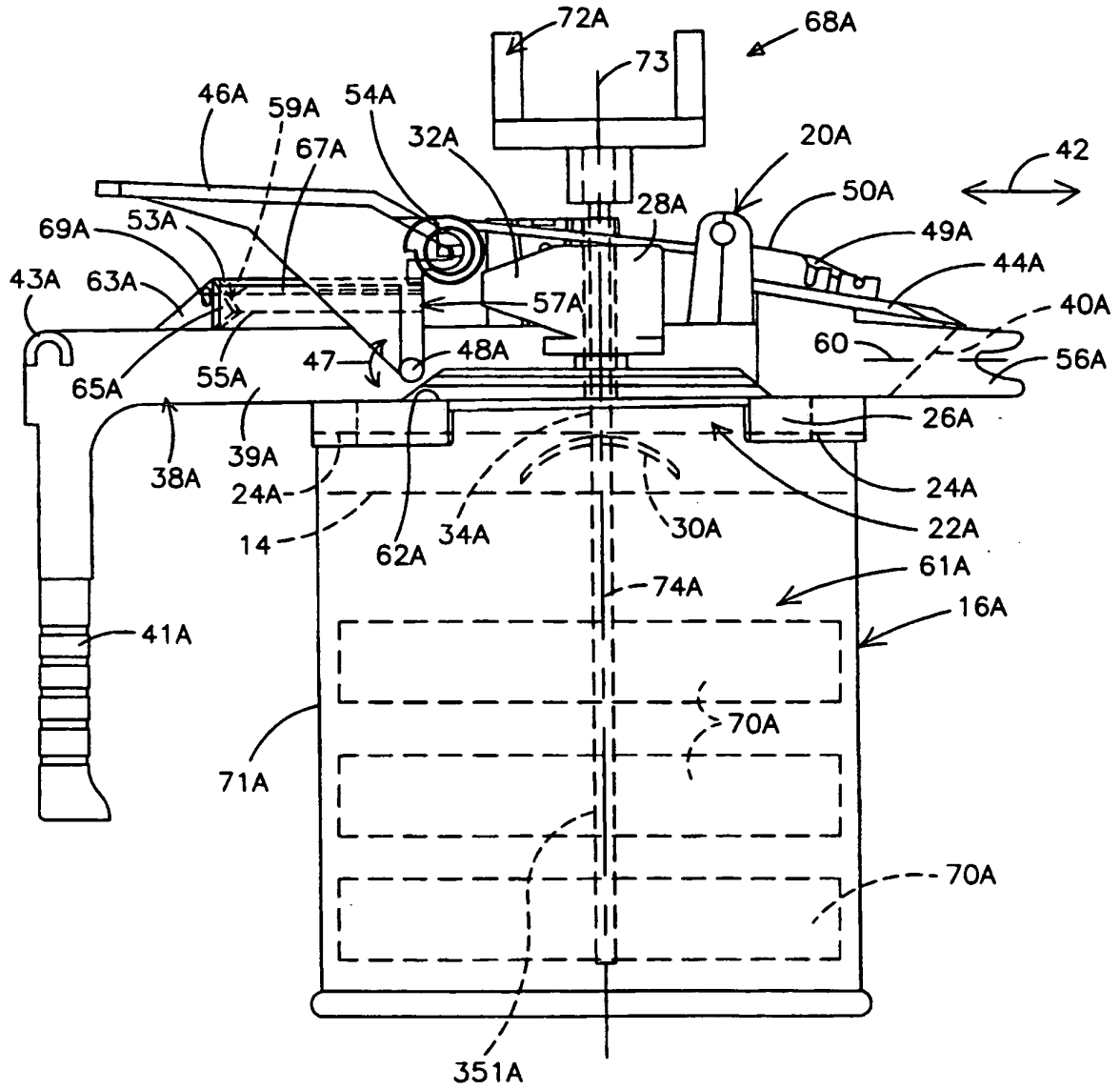

Fig. 3A

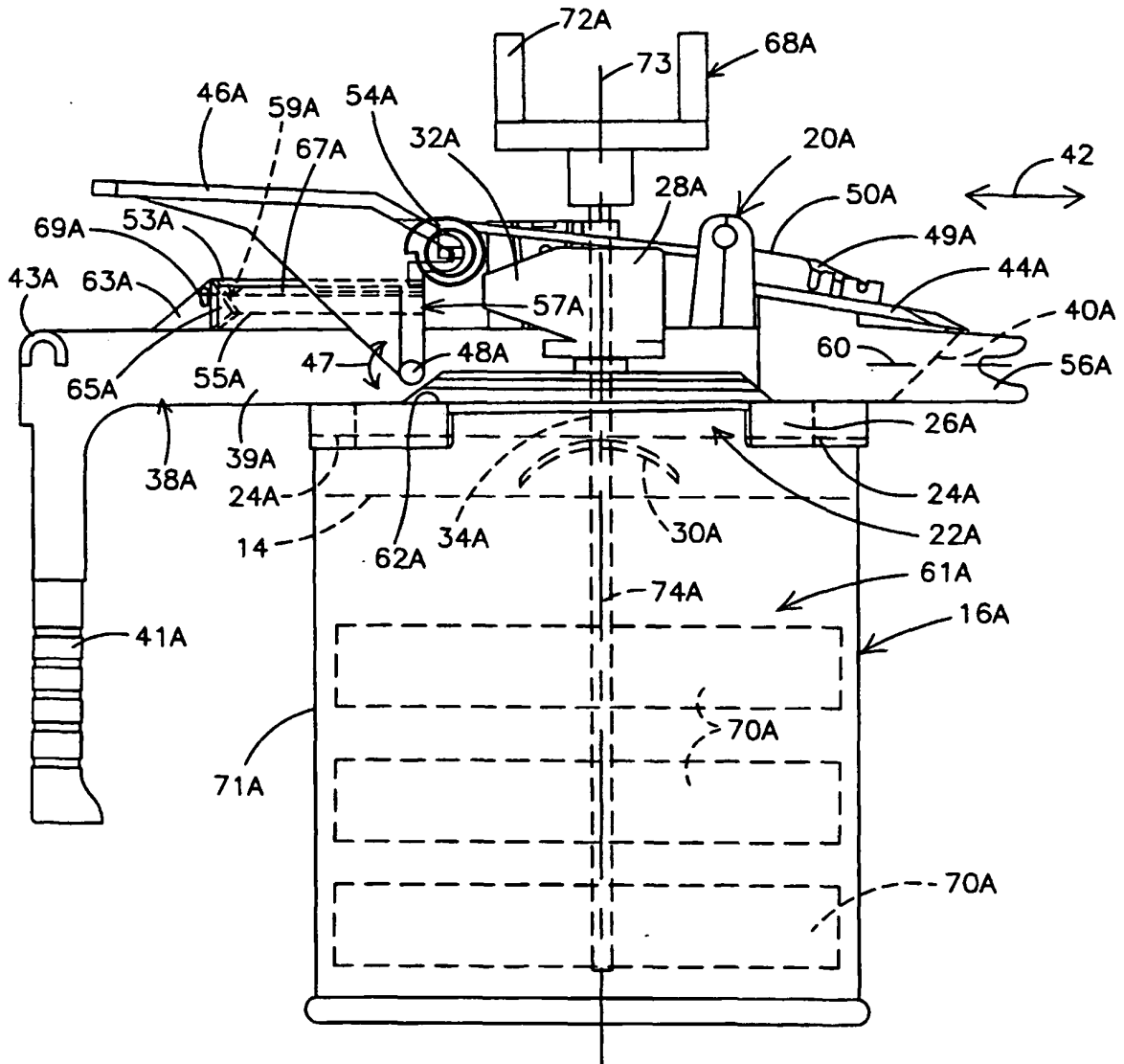

Fig. 3B

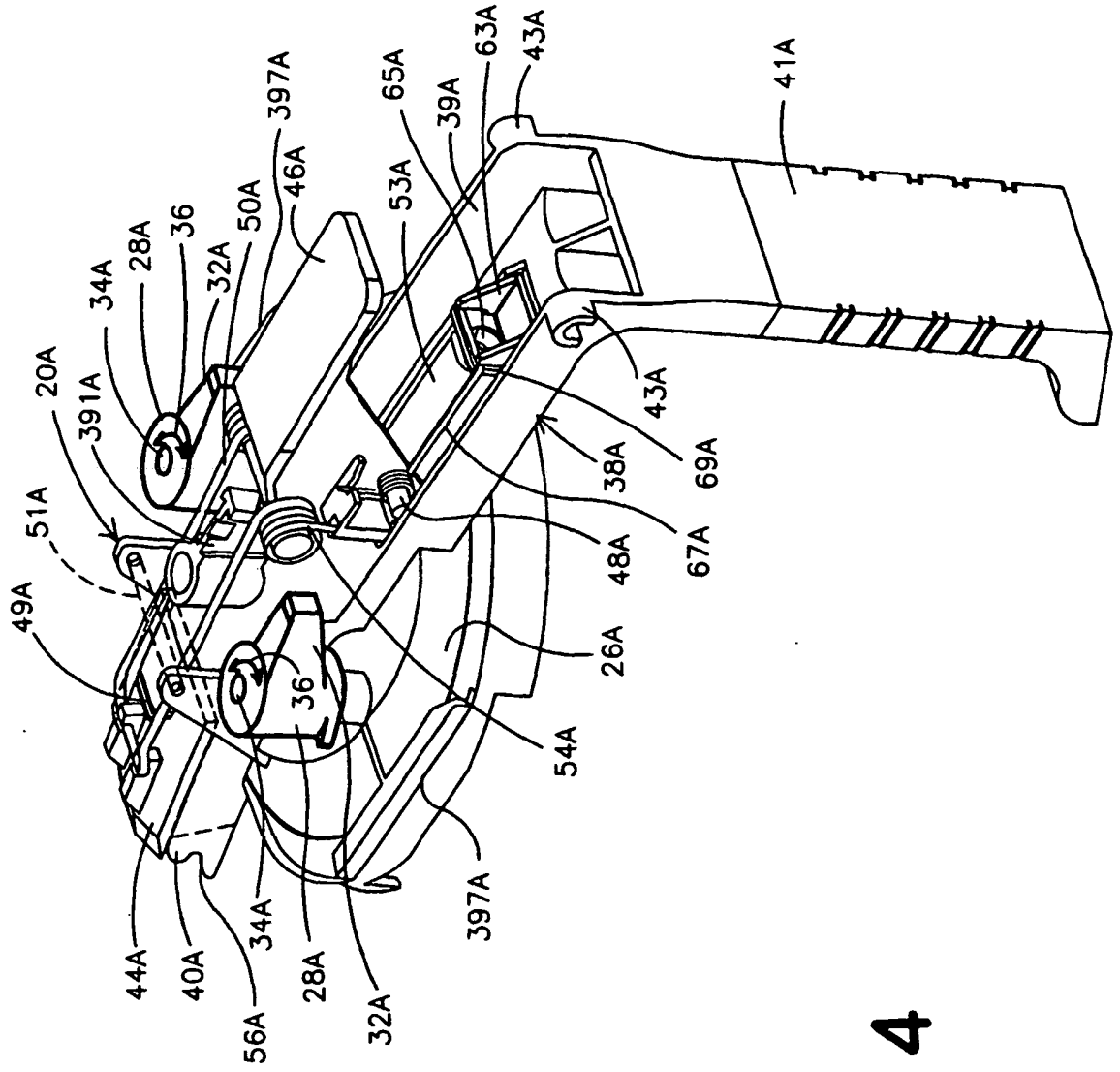

Fig. 4

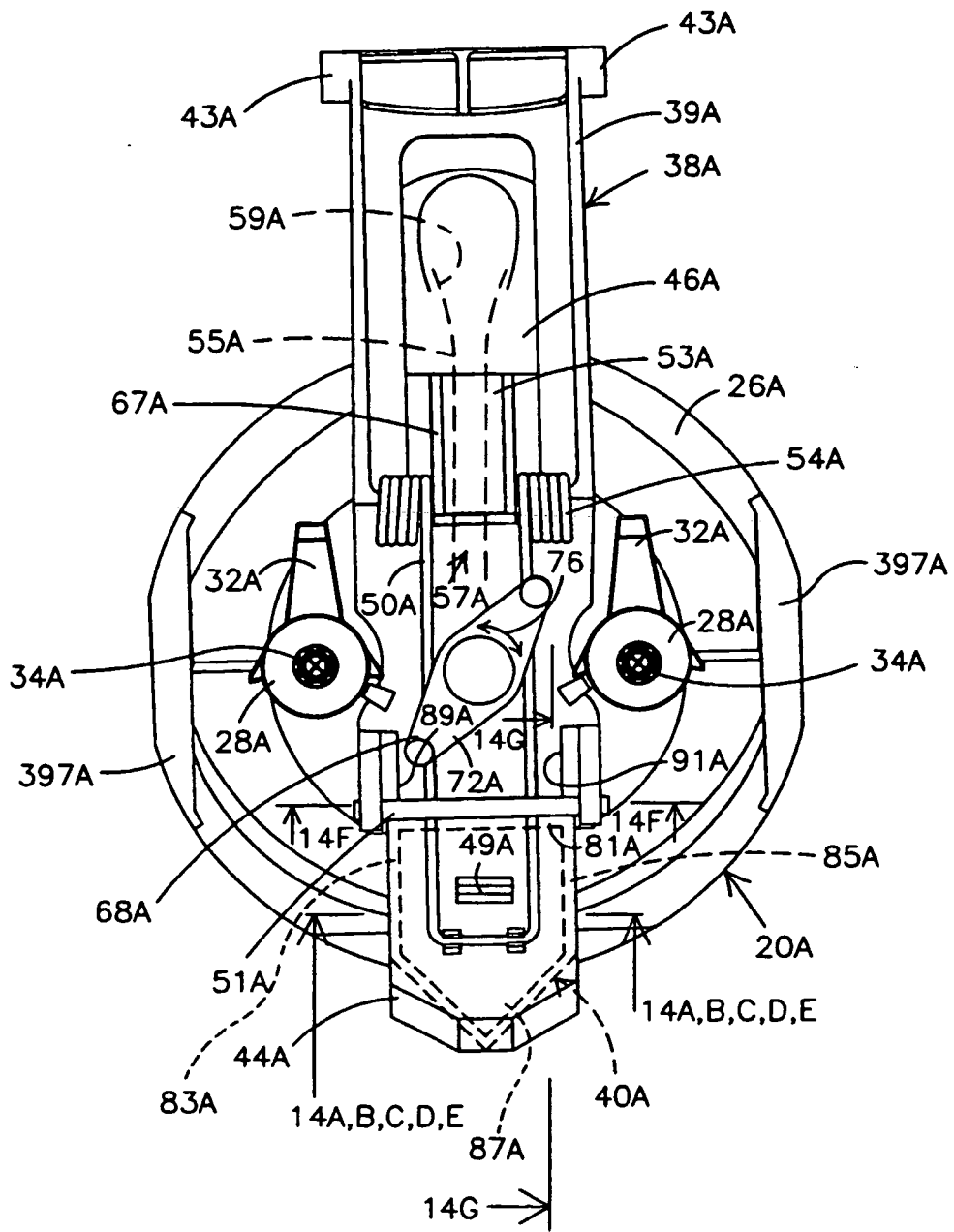

Fig. 5

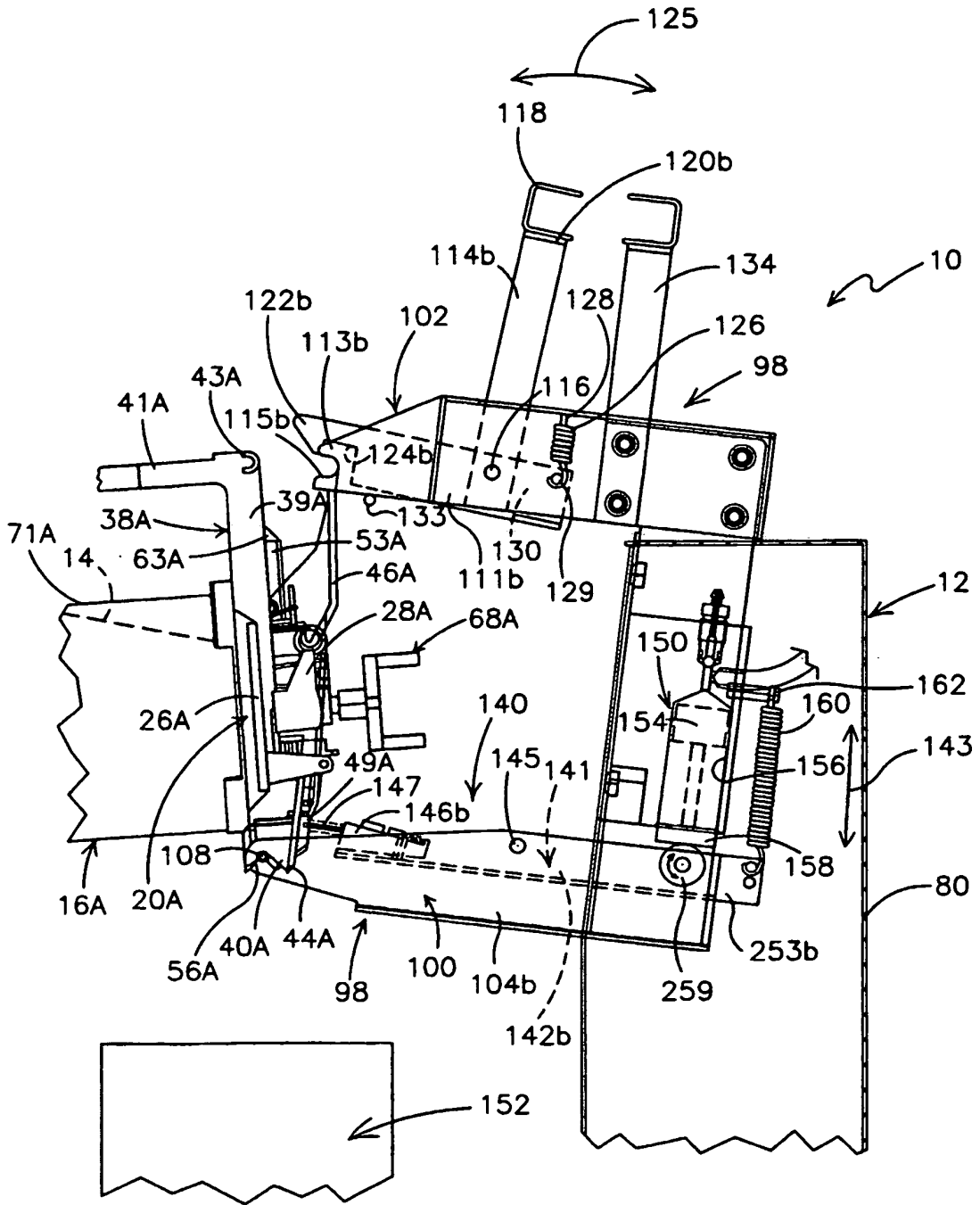

Fig. 6

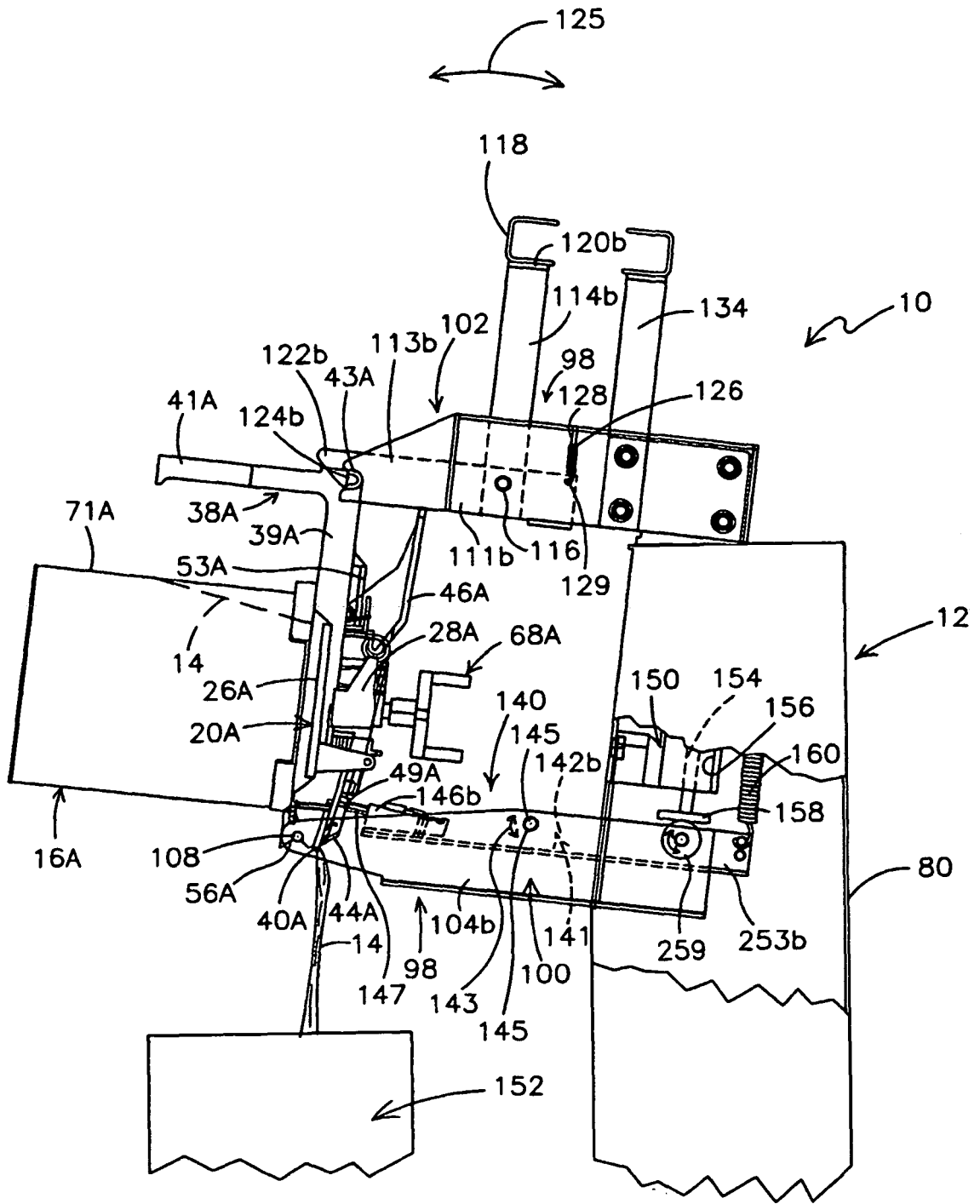

Fig. 8

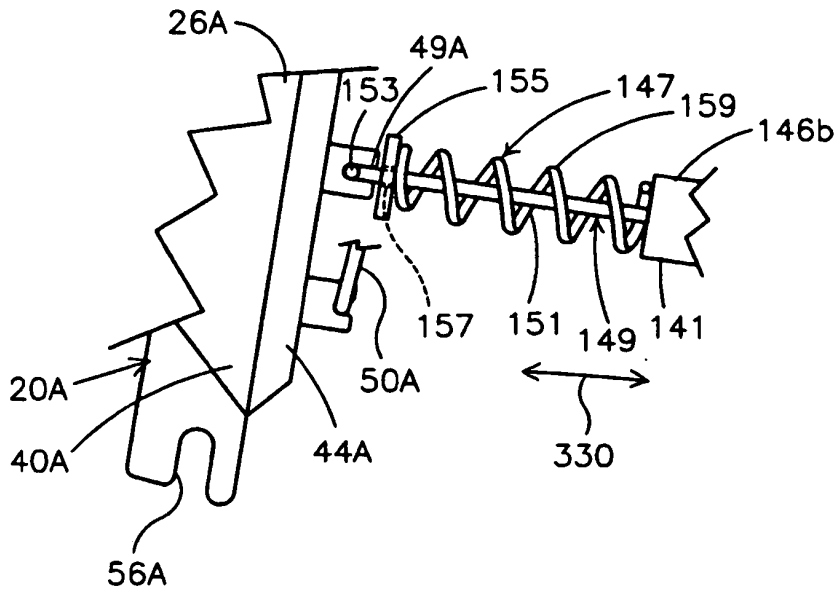

Fig. 9A

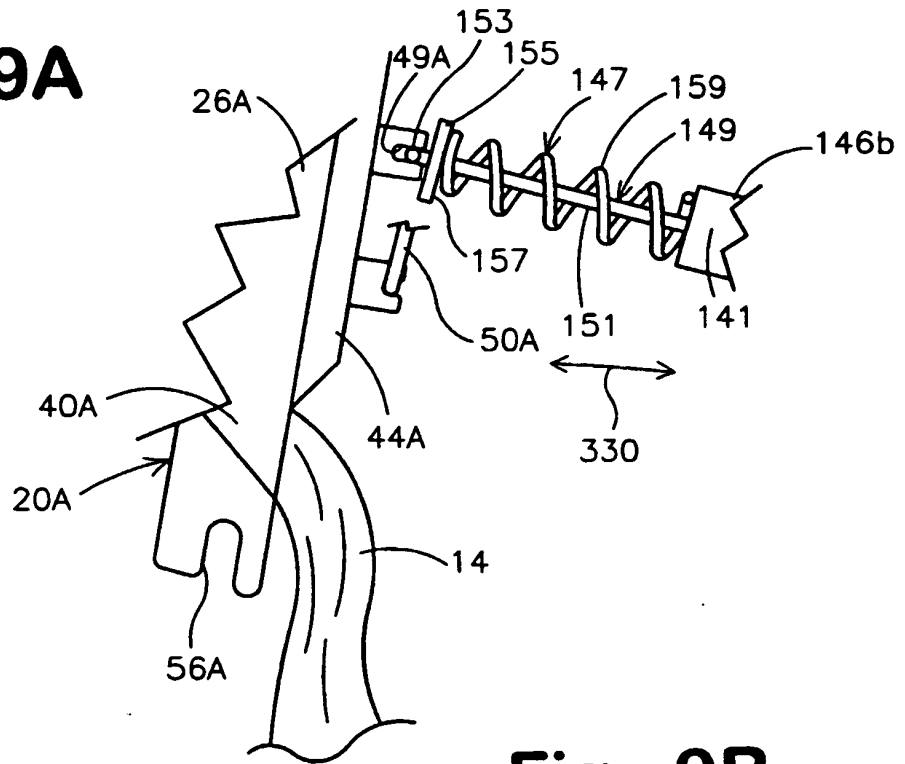

Fig. 9B

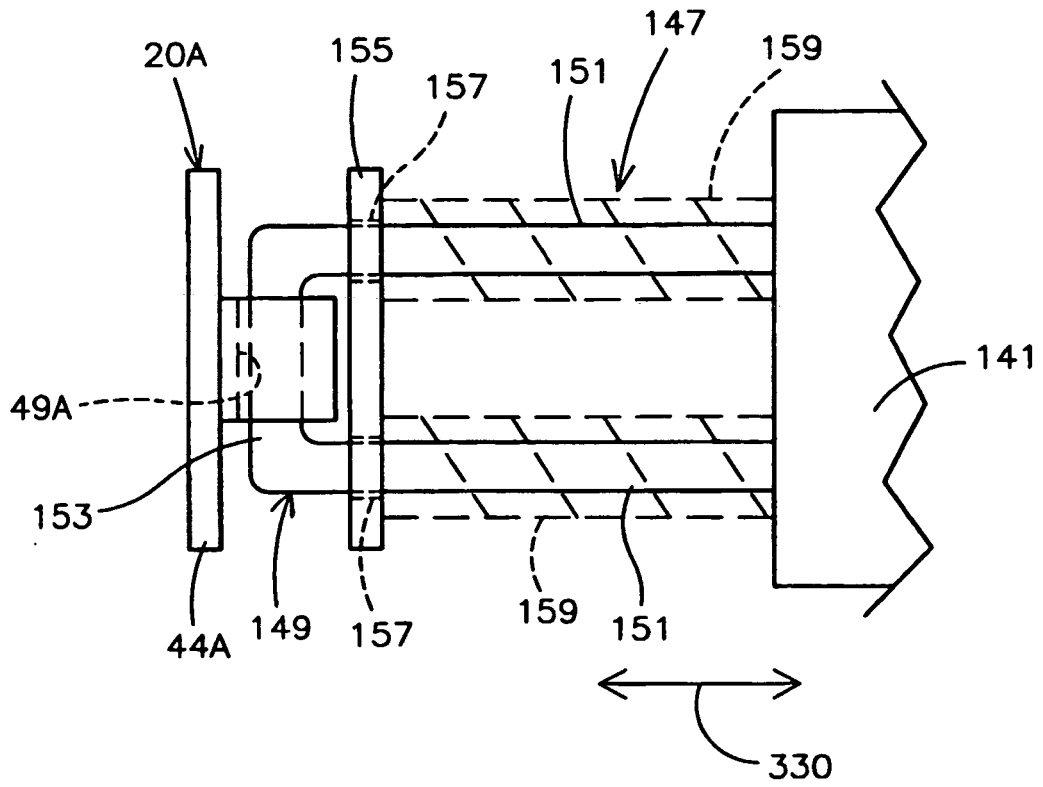

Fig. 10

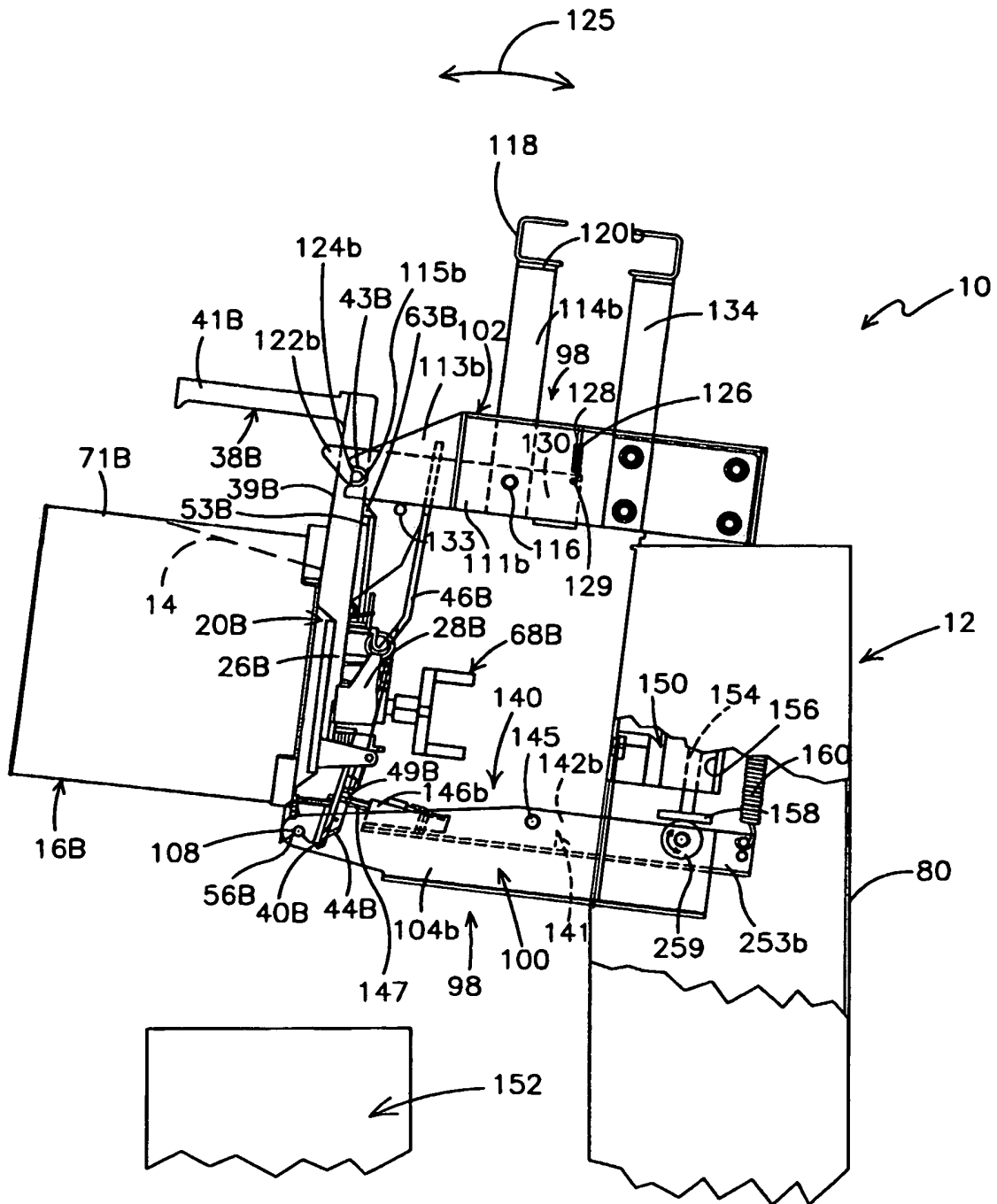

Fig. 11

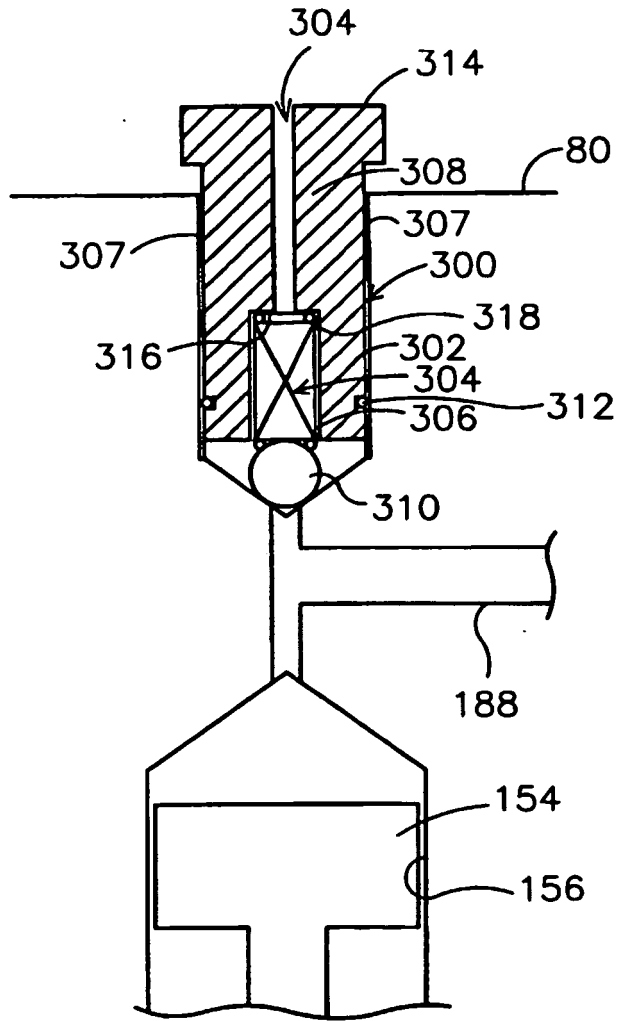

Fig. 12

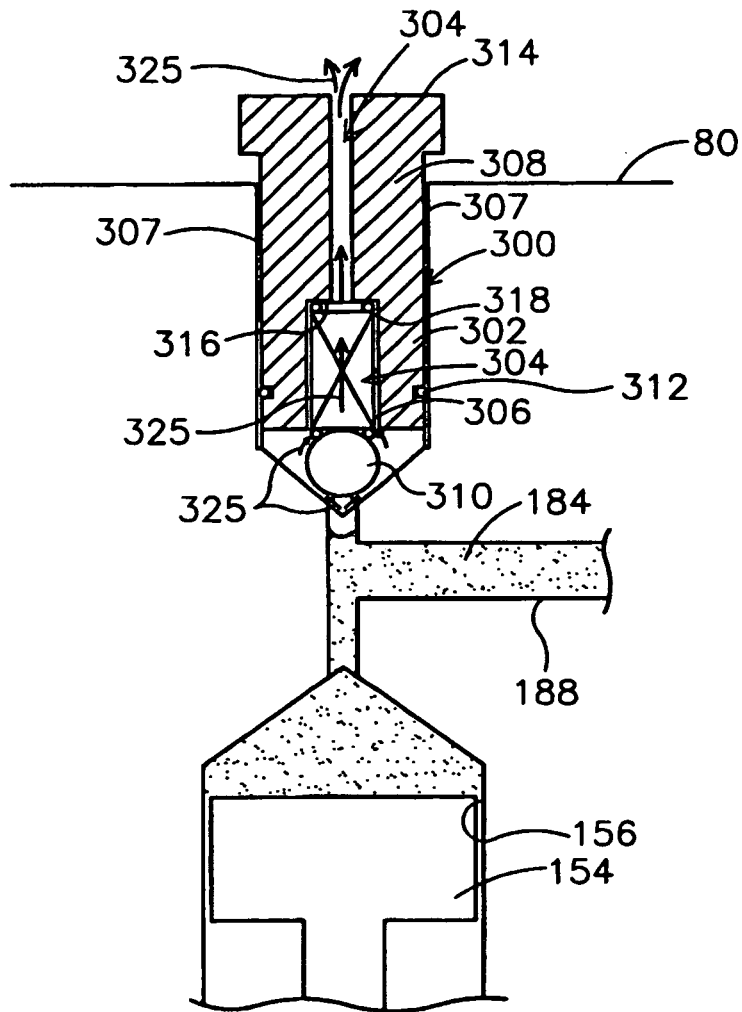

Fig. 13

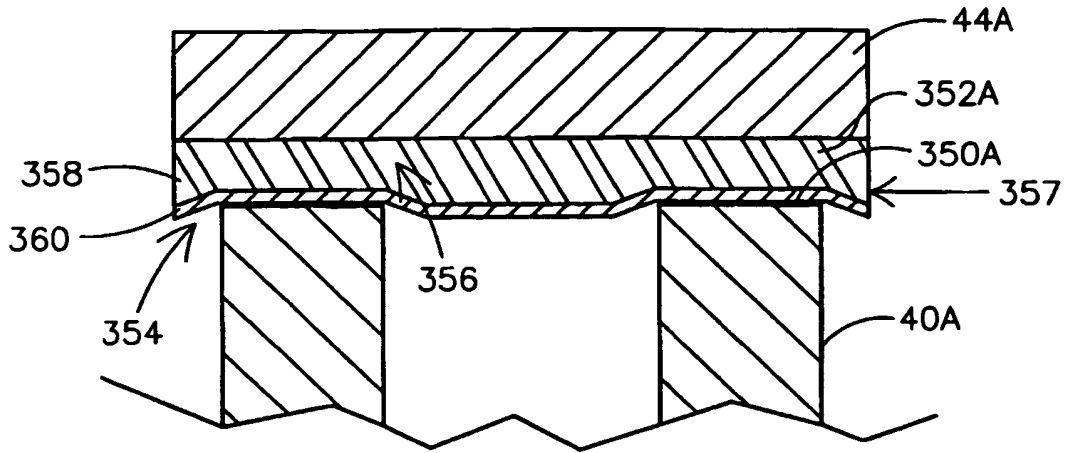

Fig. 14A

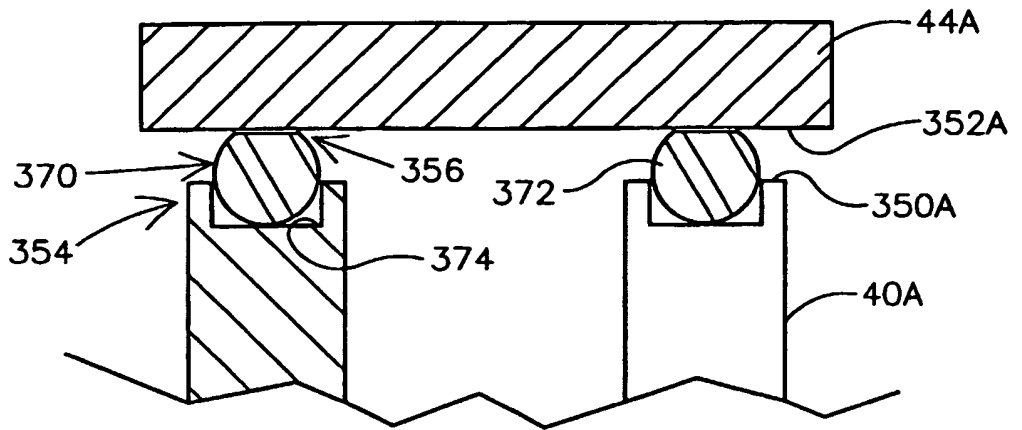

Fig. 14B

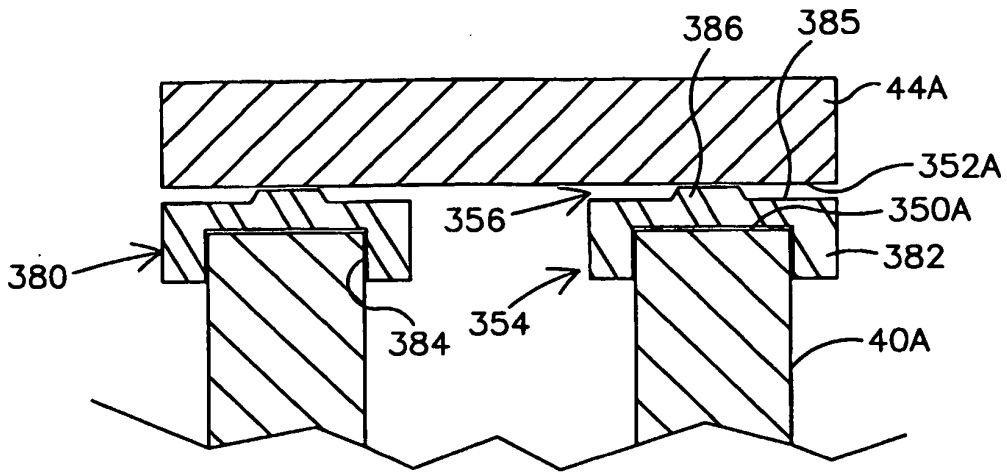

Fig. 14C

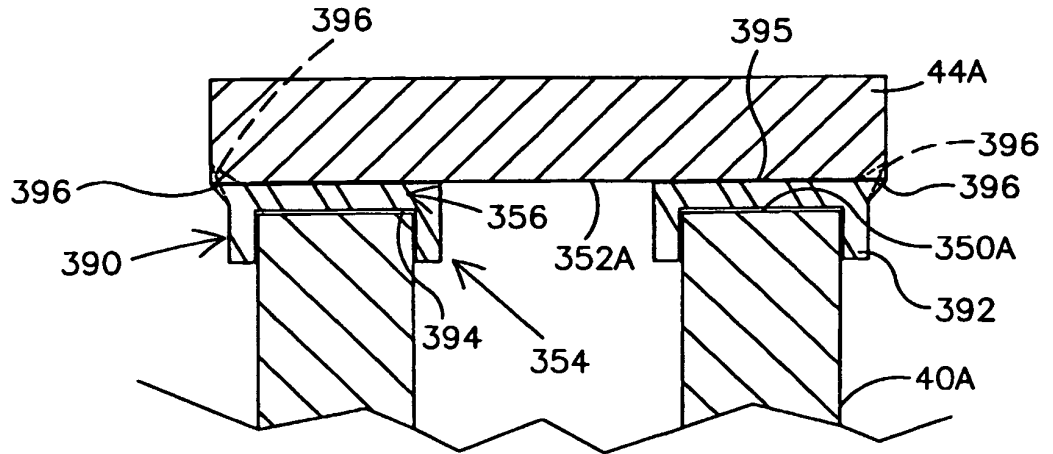

Fig. 14D

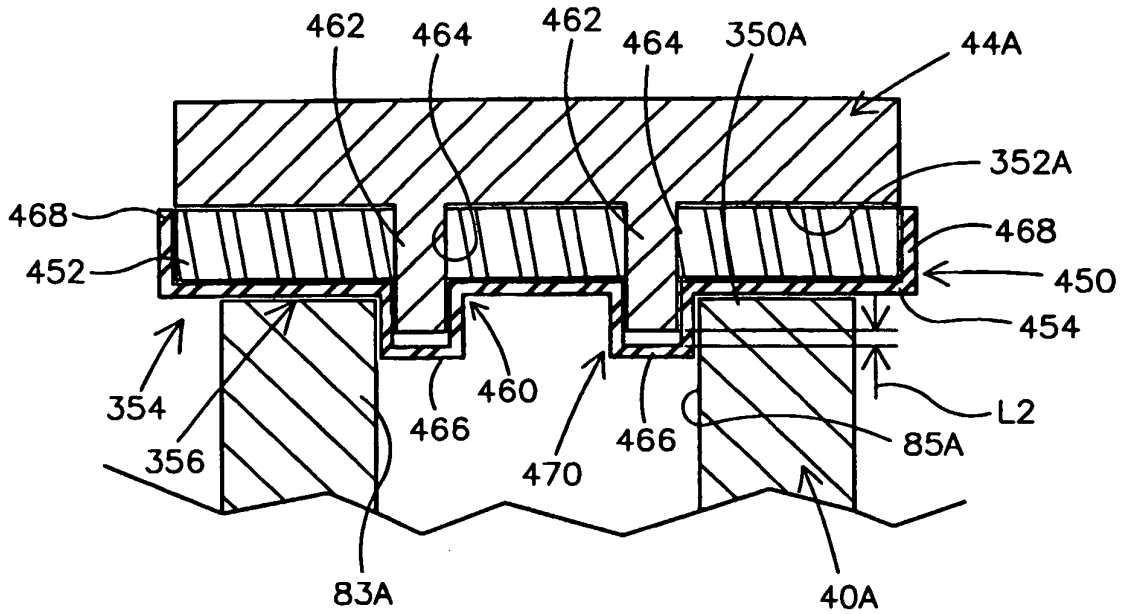

Fig. 14E

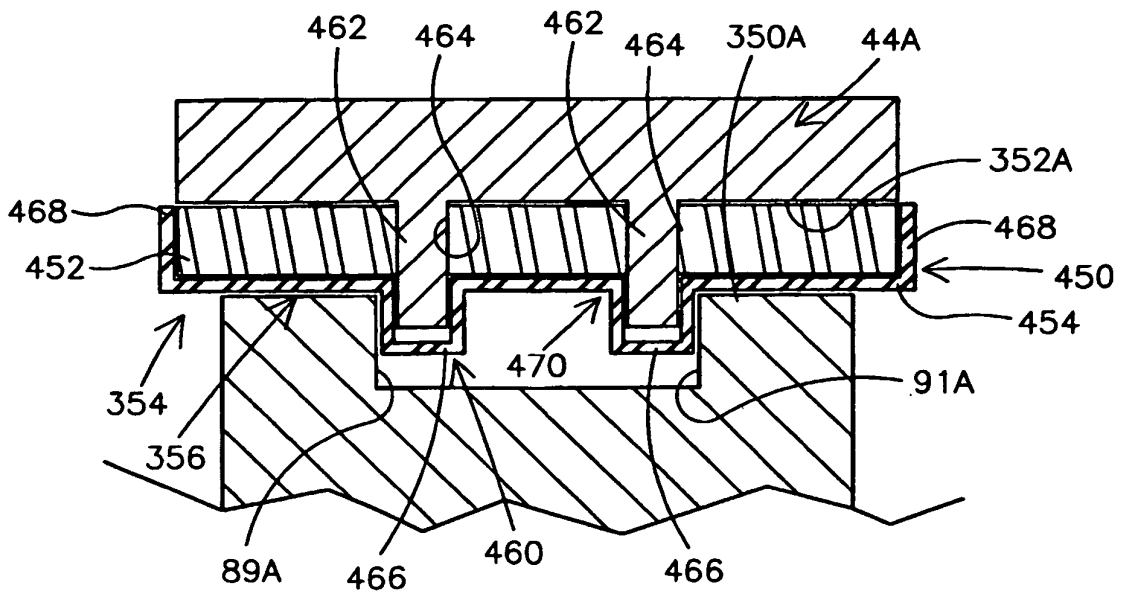

Fig. 14F

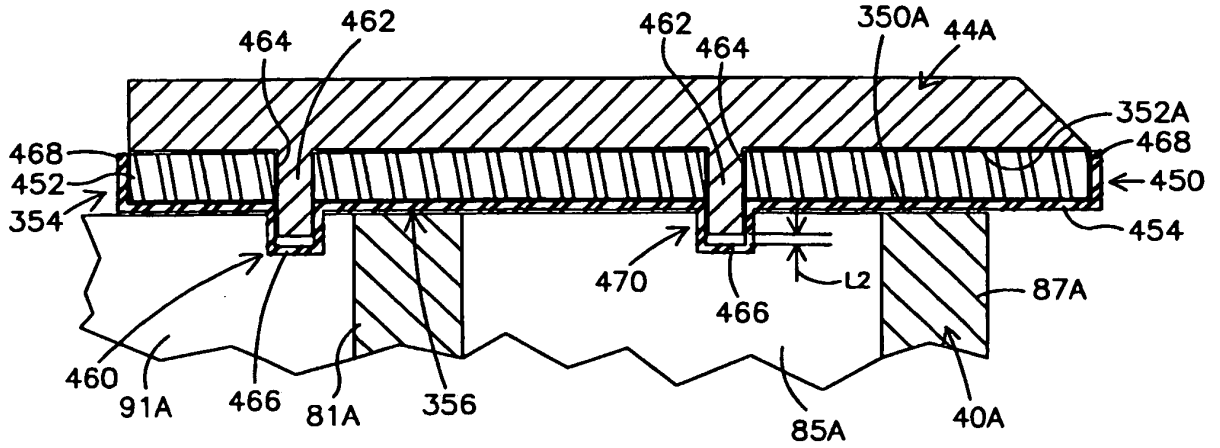

Fig. 14G

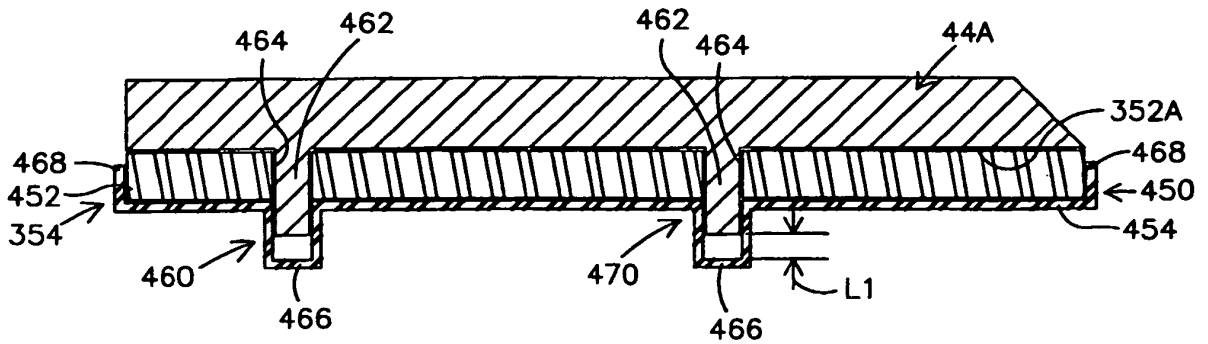
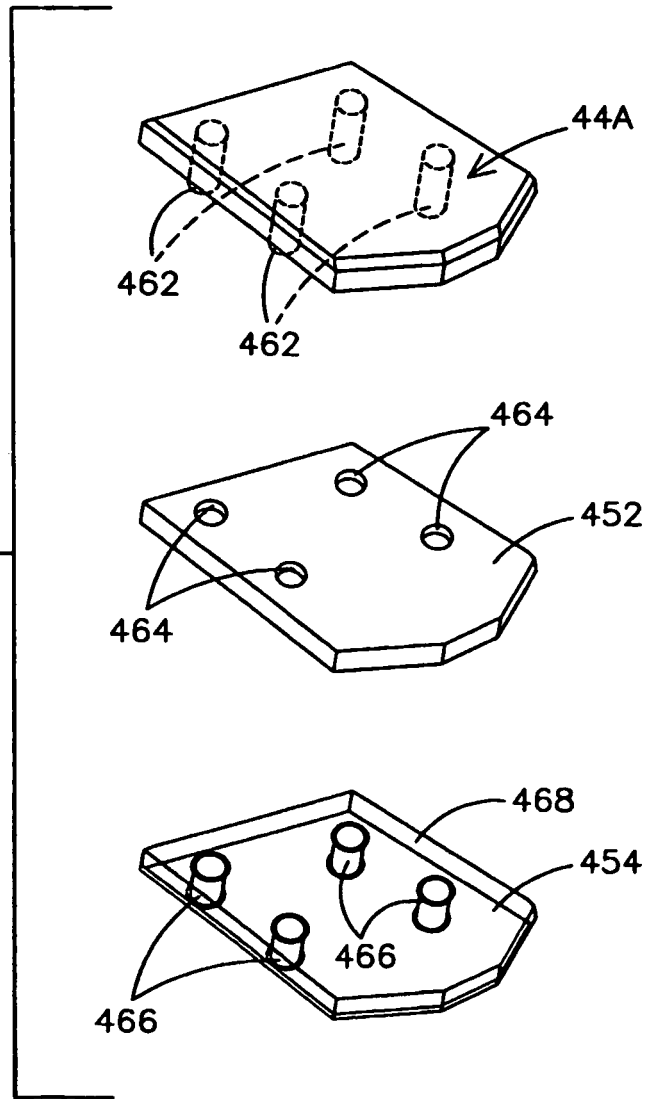

Fig. 16

Fig. 15



REFERENCES CITED IN THE DESCRIPTION

This list of references cited by the applicant is for the reader's convenience only. It does not form part of the European patent document. Even though great care has been taken in compiling the references, errors or omissions cannot be excluded and the EPO disclaims all liability in this regard.

Patent documents cited in the description

- US 41687199 A [0002]
- US 189338 A [0002]
- US 6095373 A [0002]
- US 09189214 B [0002]
- US 6053218 A [0002]
- US 417933 A [0002]
- US 416729 A [0002]
- US 41672899 A [0002]
- US 4750648 A [0007]