



(11) **EP 1 256 644 B1**

(12) **EUROPEAN PATENT SPECIFICATION**

(45) Date of publication and mention of the grant of the patent:
17.06.2009 Bulletin 2009/25

(51) Int Cl.:
D03D 47/23 (2006.01)

(21) Application number: **01830296.8**

(22) Date of filing: **08.05.2001**

(54) **Weft carrying gripper for weaving looms adjustable in respect of the thickness of the weft yarn**

Mit Bezug auf die Schussfadendicke einstellbarer Bringergreifer für Webmaschinen

Griffe d'amenée pour métiers à tisser ajustable en fonction du titrage du fil de trame

(84) Designated Contracting States:
**AT BE CH CY DE DK ES FI FR GB GR IE IT LI LU
MC NL PT SE TR**

• **Testa, Silvana**
24025 Gazzaniga,
Bergamo (IT)

(43) Date of publication of application:
13.11.2002 Bulletin 2002/46

(74) Representative: **Faggioni, Marco et al**
Fumero Studio Consulenza Brevetti Snc
Pettenkoferstrasse 20-22
80336 München (DE)

(73) Proprietor: **Promatech S.p.A.**
24020 Colzate (Bergamo) (IT)

(72) Inventors:
• **Lebbolo, Roberto**
24021 Albino (IT)

(56) References cited:
EP-A- 0 065 233 **EP-A- 0 164 034**
EP-A- 0 509 255 **EP-A- 1 013 806**
WO-A-99/29944 **FR-A- 2 278 815**

EP 1 256 644 B1

Note: Within nine months of the publication of the mention of the grant of the European patent in the European Patent Bulletin, any person may give notice to the European Patent Office of opposition to that patent, in accordance with the Implementing Regulations. Notice of opposition shall not be deemed to have been filed until the opposition fee has been paid. (Art. 99(1) European Patent Convention).

Description

[0001] The present invention concerns a weft yarn carrying gripper for weaving looms and, in particular, a carrying gripper wherein the weft yarn gripping members can be adjusted according to the thickness of the weft yarn used for each weaving operation.

[0002] As well known to the skilled in the art, a conventional weft yarn carrying gripper for looms, as for example described in EP 0 509 255 A comprises a fairly wide body, extending frontwise into a narrower portion ending with a tip. The tip is in fact meant to penetrate under the weft yarn being fed each time in front of the gripper by a weft presenting device, so as to cause said yarn to slide along the top surface of the gripper with a suitable tension until it is gripped by its gripping members. To obtain this result, the gripper body is separated from the tip portion thereof by a slit, which is oblique in respect of the motion direction of the gripper and into which the weft yarn inserts itself due to its tension and to the gripper motion; into said slit there are arranged the gripping members, apt to temporarily stop the weft yarn, at least until the exchange of the same with the weft yarn drawing gripper.

[0003] To allow the weft yarn to be inserted into the slit in a regular and repeatable manner, it is however necessary for the width of said slit to be proportional to the thickness of the weft yarn; in fact, an exceedingly narrow slit would obviously hamper the insertion of the weft yarn, but even an excessively wide slit could create problems in that it would allow a certain degree of freedom to the weft yarn, causing its unsteadiness and thereby determining an unreliable and unrepeatable insertion thereof into the gripper slit.

[0004] Thus, according to known technique, a series of weft yarn carrying grippers are produced and used for each type of loom, each of them having a slit of different width, so as to be able to mount on the loom grippers corresponding to the weft yarn being used each time for any special weaving lot. This type of solution of course creates several problems in the management of the grippers store, as well as a considerable waste of time when having to replace the grippers on the loom, seen that such an operation should include not only the times strictly required to replace the grippers, but also those required to supply the grippers having to be replaced and to store again those which have been replaced. As an alternative, each loom would have to be provided with a local store containing every possible replacement gripper, with the obvious consequence, not only of an increased bulk, but also of an inefficient optimization in handling the replacement grippers which, forming part of the equipment of each single loom, would have to be supplied in a far higher number than that actually required for the whole weaving compartment.

[0005] The object of the present invention is to thus supply a solution apt to overcome the above drawbacks, namely to allow carrying out the weaving operations with

grippers having a slit of width always corresponding to the thickness of the weft yarn being used each time, but with no need to dispose of a plurality of grippers to alternate on the loom.

[0006] This object is reached by supplying an adjustable weft yarn carrying gripper according to independent claim 1.

[0007] A weft yarn carrying gripper for weaving looms according to the present invention, of the type comprising a gripper body having a wide bearing surface for the warp yarns and a narrower tip portion separated from the gripper body by a slit for weft yarn insertion, is characterized in that at least the portion of said warp yarns bearing surface delimiting said slit is formed by an upper movable element fixed to the gripper body by adjustable fixing means, so as to allow adjusting the width of said slit.

[0008] The weft yarn carrying gripper according to the present invention will now be described in further detail, with reference to a preferred embodiment thereof, illustrated on the accompanying drawings, in which:

Fig. 1 is a plan view of the gripper according to the present invention;

Fig. 2 is a side elevation of the gripper shown in fig. 1;

Fig. 3 shows, on an enlarged scale, the front portion of the gripper of fig. 1, clearly illustrating the slit which separates the gripper body from the tip portion thereof;

Fig. 4 is a plan view illustrating only the upper adjustable element of the gripper body; and

Fig. 5 is a side elevation of the upper adjustable element of the gripper body.

[0009] A conventional weft yarn carrying gripper can be functionally subdivided into a body 1 and a tip portion 2, as shown in Fig. 1 and Fig. 3 in relation to the gripper body according to the present invention. The gripper body 1 essentially consists - in known manner - of an elongated bottom element 3, meant to be fixed to the gripper carrying strap, and of a wide flat top surface 4 onto which bear the warp yarns during the initial/final step of inlet/outlet of the gripper into and out of the shed. Between the bottom element 3 and the top surface 4 there are arranged the members to grip the weft yarn T; such members are only diagrammatically illustrated in fig. 2, since they are by no means involved in the present invention.

[0010] As already mentioned above, the tip portion 2 of the gripper is less wide than the gripper body 1 and is separated therefrom by an oblique slit 5 allowing to insert into the gripper the weft yarn T. To facilitate this operation, the tip portion 2 is less high than the body 1 and is radiused to said body in a smoothly inclined manner, so as to form a beveling in correspondence of the slit 5, apt to steadily hold the weft yarn T and facilitate its correct insertion into the gripper. The working of the carrying gripper during the weft yarn gripping step and the function of the slit 5 have already been widely described in the

introductory part of the present description, whereby it is not deemed necessary to dwell any further on this argument.

[0011] According to the innovating aspect of the present invention, in order to be able to dispose of a slit 5 of the desired width required for each single weaving operation, the invention proposes to use a single gripper in which said width can be easily adjusted, instead of adopting different grippers each having a slit of preset fixed width, as done in previous technique.

[0012] According to the present invention said result is obtained by forming at least part of the gripper top surface 4 - namely, at least said portion which delimits the slit 5 - as a movable upper element 6, fixed to the gripper body by adjustable fixing means and slidable on an underlying sliding plane, formed into the gripper body 1 and apt to supply a steady support for the upper element 6 in any position thereof. The upper element 6 lies on the same plane and is perfectly aligned with the remaining fixed part of the surface 4, so that the ensemble formed by the fixed part of the surface 4 and the movable surface of the upper element 6 appears as a single continuous bearing surface for the warp yarns, independently from the position taken up each time by the upper element 6 in order to adjust the width of the slit 5.

[0013] In the embodiment shown, the line of separation between the fixed surface 4 and the upper element 6 is a line parallel to the longitudinal axis of the gripper, and the adjustable fixing means consist of screws 7 of small diameter (for example M2 screws) which screw into corresponding threaded seats, provided in the gripper body 1, by crossing slots 8 (figs. 4 and 5) formed into suitable ears 9 projecting perpendicularly from the upper element 6. The ears 9, and thus the slots 8 and the screws 7, are positioned in the bottom part of the upper element 6 and are hence perfectly "hidden" either by said upper element 6 or by the surface 4, so that the screws 7, though being within easy reach for adjustment from a lateral position, are never apt to interfere with the warp yarns during the gripper motion.

[0014] The width of the slots 8 determines the possible travel of the upper element 6 between an advanced position, in which the slit 5 has the minimum width, and a setback position in which said slit 5 has a maximum width, the upper element 6 always keeping - in any of the possible positions taken up during its travel - perfectly adjacent to the fixed surface 4. To make sure that the union between these two surfaces is perfectly even, the upper element 6 ends, on the side of the surface 4, with a toothed longitudinal rib 10 apt to engage with a conjugate rib provided in the surface 4.

[0015] The adjustment of the width of the slit 5 is very simple, as besides clearly results from the above description. It is in fact sufficient to loosen the two screws 7, to cause the upper element 6 to slide forward or backward up to obtaining the required width of the slit 5 - eventually using graduated shims to insert into said slit - and to then tighten again the screws 7 in the new position taken up

by the upper element 6. The entire operation of adjustment can be carried out in a few seconds, namely in positively shorter times than those currently required for the replacement of the whole gripper.

[0016] From the previous description it should be clearly evident how the weft yarn carrying gripper according to the present invention has fully reached the intended objects. In fact, said gripper allows to obtain an easy and fast adjustment of the width of the slit 5 for weft yarn insertion, whereby it fully eliminates the need to store a series of grippers having slits 5 of different width; it moreover drastically reduces the times required to adapt the loom to the weaving operations with weft yarns of different thicknesses, and it allows to optimize - from the economical point of view, as well as for what concerns the supply of spare parts - the management of the grippers in the weaving compartment.

20 Claims

1. Weft yarn carrying gripper for weaving looms of the type comprising a gripper body (1) having a wide bearing surface (4) for the warp yarns and a narrower tip portion (2) separated from the gripper body (1) by a slit (5) for weft yarn insertion, **characterized in that** at least the portion of said warp yarns bearing surface (4) delimiting said slit (5) is formed by an upper movable element (6) fixed to the gripper body (1) by adjustable fixing means, so as to allow adjusting the width of said slit (5).
2. Weft yarn carrying gripper as in claim 1), wherein the surface of said upper movable element (6) lies on the same plane and is perfectly aligned, in any position of said plane, with the surface of the remaining fixed part of the warp yarns bearing surface (4).
3. Weft yarn carrying gripper as in claim 1), wherein said upper movable element (6) bears onto a corresponding sliding plane provided on the gripper body (1).
4. Weft yarn carrying gripper as in claim 3), wherein said adjustable fixing means consist of at least one pair of screws (7), apt to engage into corresponding threaded seats provided in the gripper body (1) and crossing slots (8) formed into ears (9) projecting from the bottom part of said upper movable element (6).
5. Weft yarn carrying gripper as in claim 4), wherein said ears (9) are perpendicular to the surface of the upper movable element (6) and the axis of said screws (7) is parallel to said surface.
6. Weft yarn carrying gripper as in claim 4), wherein said ears (9) are positioned inwardly in respect of the free outer edge of said upper movable element

- (6).
7. Weft yarn carrying gripper as in claim 3), wherein the edges of contact between said upper movable element (6) and said fixed part of the warp yarns bearing surface (4) are formed as conjugate toothed ribs (10).
8. Weft yarn carrying gripper as in claim 3) wherein, during adjustment of the width of said slit (5), said upper movable element (6) moves in a direction parallel to the longitudinal axis of the gripper.

Patentansprüche

1. Schussfadentragegreifer für Webmaschinen - von der Art mit einem Greiferkörper (1) mit einer breiten Auflagefläche (4) für die Kettfäden und einem schmalen Spitzenabschnitt (2), der von dem Greiferkörper (1) durch einen Schlitz (5) zum Einsetzen des Schussfadens getrennt ist - **dadurch gekennzeichnet, dass** wenigstens der Abschnitt der Kettfadenaufnahme­fläche (4), der den Schlitz (5) begrenzt, durch ein oberes bewegliches Element (6) gebildet ist, das an dem Greiferkörper (1) durch einstellbare Fixierungsmittel befestigt ist, um so ein Einstellen der Breite des Schlitzes (5) zu erlauben.
2. Schussfadentragegreifer nach Anspruch 1, wobei die Fläche des oberen beweglichen Elements (6) in derselben Ebene liegt und in jeder Position der Ebene mit der Fläche der Kettfadenauf­lage­fläche (4) vollständig ausgerichtet ist.
3. Schussfadentragegreifer nach Anspruch 1, wobei das obere bewegliche Element (6) auf einer entsprechenden Gleitebene liegt, die an dem Greiferkörper (1) ausgebildet ist.
4. Schussfadentragegreifer nach Anspruch 3, wobei das einstellbare Fixierungsmittel aus wenigstens einem Paar von Schrauben (7) besteht, die zum Eingreifen in entsprechende Gewindesitze, die in dem Greiferkörper (1) vorgesehen sind, und in kreuzende Schlitz­e (8), die in Ösen (9), die von dem Bodenteil des oberen beweglichen Elements (6) vorragen, geeignet sind, bestehen.
5. Schussfadentragegreifer nach Anspruch 4, wobei die Ösen (9) senkrecht zu der Fläche des oberen beweglichen Elements (6) liegen und die Achse der Schrauben (7) parallel zu der Fläche liegt.
6. Schussfadentragegreifer nach Anspruch 4, wobei die Ösen (9) nach innen bezüglich des freien äußeren Randes des oberen beweglichen Elements (6) positioniert sind.

7. Schussfadentragegreifer nach Anspruch 3, wobei die Ränder des Kontaktes zwischen dem oberen beweglichen Element (6) und dem fixierten Teil der Kettfadenauf­lage­fläche (4) als paarig gezahnte Rippen (110) ausgebildet sind.
8. Schussfadentragegreifer nach Anspruch 3, wobei während der Einstellung der Breite des Schlitzes (5) das obere bewegliche Element (6) sich in einer Richtung parallel zu der Längsachse des Greifers bewegt.

Revendications

1. Griffes d'amenée de fil de trame pour des métiers à tisser du type comportant un corps de griffe (1) ayant une large surface (4) d'appui pour les fils de trame et une partie de bout plus étroite (2) séparée du corps de griffe (1) par une fente (5) pour une insertion de fil de trame, **caractérisée en ce qu'**au moins la partie de ladite surface d'appui (4) pour fils de trame délimitant ladite fente (5) est formée par un élément supérieur mobile (6) fixé au corps de griffe (1) par un moyen de fixation réglable, afin de permettre un réglage de la largeur de ladite fente (5).
2. Griffes d'amenée de fil de trame selon la revendication 1, dans laquelle la surface dudit élément supérieur mobile (6) s'étend sur le même plan que, et est parfaitement alignée, dans n'importe quelle position dudit plan, avec la surface de la partie fixe restante de la surface (4) d'appui pour fils de trame.
3. Griffes d'amenée de fil de trame selon la revendication 1, dans laquelle ledit élément supérieur mobile (6) porte sur un plan de glissement correspondant situé sur le corps de griffe (1).
4. Griffes d'amenée de fil de trame selon la revendication 3, dans laquelle lesdits moyens de fixation réglables consistent en au moins une paire de vis (7), aptes à être engagés dans des logements filetés correspondants prévus dans le corps de griffe (1) et croisant des trous oblongs (8) formés dans des pattes (9) faisant saillie de la partie de dessous dudit élément supérieur mobile (6).
5. Griffes d'amenée de fil de trame selon la revendication 4, dans laquelle lesdites pattes (9) sont perpendiculaires à la surface de l'élément supérieur mobile (6) et l'axe desdites vis (7) est parallèle à ladite surface.
6. Griffes d'amenée de fil de trame selon la revendication 4, dans laquelle lesdites pattes (9) sont positionnées vers l'intérieur par rapport au bord extérieur libre dudit élément supérieur mobile (6).

7. Griffes d'aménage de fil de trame selon la revendication 3, dans laquelle les bords de contact entre ledit élément supérieur mobile (6) et ladite partie fixe de la surface (4) d'appui pour fils de trame sont réalisés sous la forme de nervures dentées conjuguées (10). 5
8. Griffes d'aménage de fil de trame selon la revendication 3, dans laquelle, pendant un réglage de la largeur de ladite fente (5), ledit élément supérieur mobile (6) se déplace dans une direction parallèle à l'axe longitudinal de la griffe. 10

15

20

25

30

35

40

45

50

55

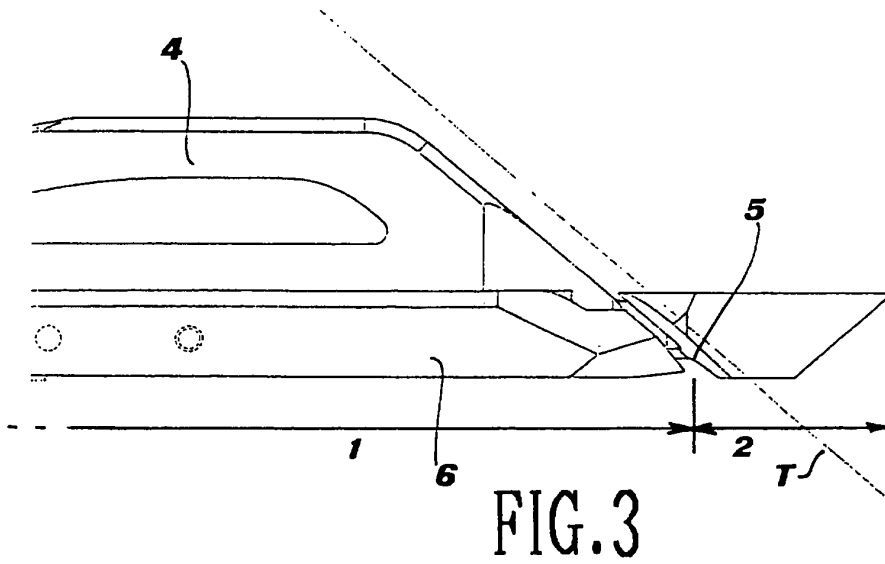
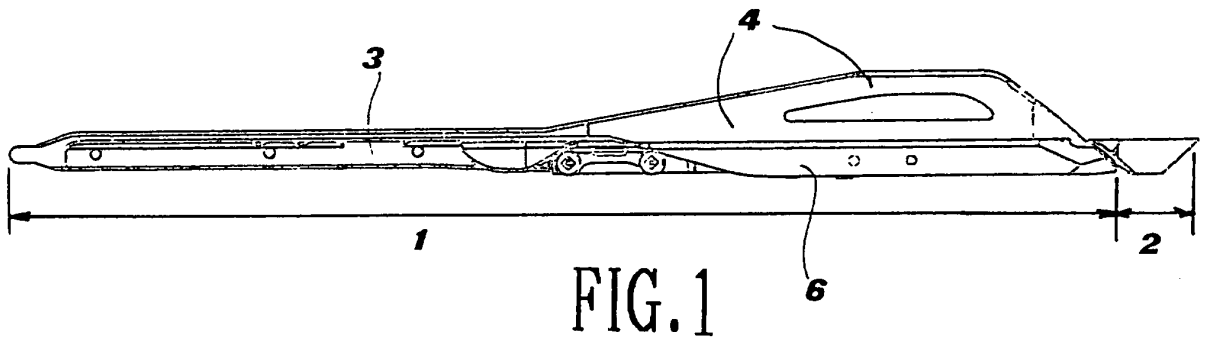
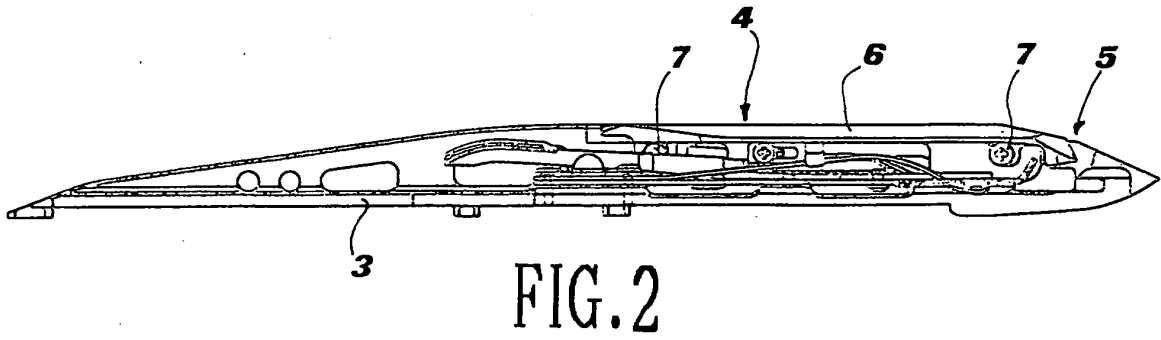

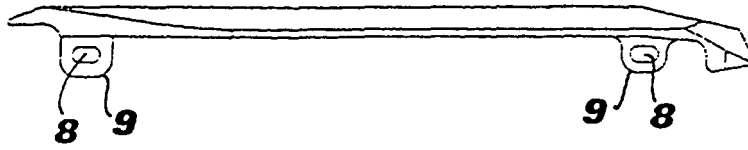

FIG. 5

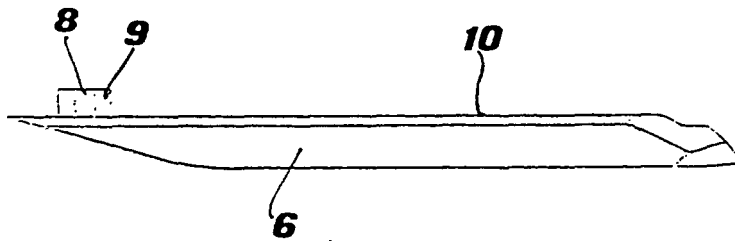

FIG. 4

REFERENCES CITED IN THE DESCRIPTION

This list of references cited by the applicant is for the reader's convenience only. It does not form part of the European patent document. Even though great care has been taken in compiling the references, errors or omissions cannot be excluded and the EPO disclaims all liability in this regard.

Patent documents cited in the description

- EP 0509255 A [0002]