

(19)



(11)

**EP 1 276 410 B2**

(12)

**NEW EUROPEAN PATENT SPECIFICATION**

After opposition procedure

(45) Date of publication and mention  
of the opposition decision:  
**15.11.2017 Bulletin 2017/46**

(45) Mention of the grant of the patent:  
**07.10.2009 Bulletin 2009/41**

(21) Application number: **01918149.4**

(22) Date of filing: **02.03.2001**

(51) Int Cl.:  
**A47L 9/02 (2006.01)**

(86) International application number:  
**PCT/TR2001/000009**

(87) International publication number:  
**WO 2001/065991 (13.09.2001 Gazette 2001/37)**

(54) **VACUUM CLEANER NOZZLE**

STAUBSAUGERMUNDSTÜCK

SUCEUR D'ASPIRATEUR

(84) Designated Contracting States:  
**AT BE CH CY DE DK ES FI FR GB GR IE IT LI LU  
MC NL PT SE TR**  
Designated Extension States:  
**AL LT LV MK RO SI**

(30) Priority: **10.03.2000 TR 200000719**

(43) Date of publication of application:  
**22.01.2003 Bulletin 2003/04**

(73) Proprietor: **ARÇELIK A.S.**  
**34950 Istanbul (TR)**

(72) Inventors:  
• **MELAMET, Beni**  
**81100 Istanbul (TR)**  
• **DURST, Franz,**  
**LSTM Friedrich Alexander Universität**  
**91058 Nürnberg (DE)**

(74) Representative: **Louis Pöhlau Lohrentz**  
**Patentanwälte**  
**Postfach 30 55**  
**90014 Nürnberg (DE)**

(56) References cited:  
**EP-A- 0 302 515 EP-A- 0 898 923**  
**CH-A- 341 964 DE-A- 3 801 757**  
**DE-A1- 2 414 826 DE-A1- 3 732 483**  
**DE-U1- 8 716 492 US-A- 2 254 363**  
**US-A- 3 210 792 US-A- 4 336 628**

- **PATENT ABSTRACTS OF JAPAN vol. 016, no. 533 (C-1002), 4 November 1992 (1992-11-04) -& JP 04 200519 A (TOKYO ELECTRIC CO LTD), 21 July 1992 (1992-07-21)**
- **PATENT ABSTRACTS OF JAPAN vol. 1997, no. 11, 28 November 1997 (1997-11-28) -& JP 09 182696 A (TEC CORP), 15 July 1997 (1997-07-15)**

**EP 1 276 410 B2**

## Description

**[0001]** The present invention relates to increasing the efficiency and dust pick-up and collecting performance of the brush used in vacuum cleaners.

**[0002]** Vacuum cleaners are machines with very low efficiency values. The power of the motor used in the vacuum cleaners is 1400 W. However only 300 W of this power is used for an efficient dust suction. Furthermore this power value of 300 W is consumed only for the suction of micron sized dust particles. For this reason, there is a need of a vacuum cleaner with a much higher efficiency, having a maximum dust pick up capacity at a lower power value.

**[0003]** In the state of art such as set out in US 4 336 628, a suction inlet is arranged in the middle or near to the front of the base of the brush used in the vacuum cleaners. As the dirt or dust is picked up from the ground depending on the suction capacity of the vacuum cleaner, it is directed towards the said suction inlet by means of the channels located at the bottom surface of the brush. Channels are provided along the bottom of the brush, in order to provide a uniform pressure distribution along its bottom surface as well as to provide a homogeneous suction. By means of these channels, a balanced and uniform dust pick-up and suction from the middle, right and left sections of the brush is provided. The inlet openings provided on both ends of the channel located at the front section of the brush bottom surface are narrow and the channel widens towards the suction inlet port. Moreover these channels are arranged symmetrically on the right and left sides of the brush. The pressure distribution created at the base of the brush is an important parameter influencing the dust pick up and suction. However, with regard to the suction characteristics of all these brushes, dust is sucked-in from a single point. As the suction inlet port is located at the centre of the brush, the zone where maximum dust suction is realized is the middle part of the brush; therefore high pressure values are created at the bottom of the brush and a homogeneous suction cannot be provided along the width of the said brush. In this case, the use of the brush causes difficulties for the user by increasing the force applied at the direction opposite to that applied by the user.

**[0004]** The object of the present invention is to increase the efficiency and dust pick up performance of the brush used in the vacuum cleaners.

**[0005]** The vacuum cleaner brush realized in order to attain the above object of the present invention is illustrated in the attached drawings, wherein:

Figure 1, is the view of the prior art vacuum cleaner brush, shown from the bottom.

Figure 2, is the cross-sectional view of the vacuum cleaner brush taken from the line A-A.

Figure 3, in the bottom view of the vacuum cleaner brush.

Figure 4, is the perspective view of the guide.

**[0006]** The reference numerals of the components shown in the drawings:

1. Brush
2. Guide
3. Profile
4. Suction inlet port
5. Suction inlet port window
6. Lateral edge
7. Base of the brush
8. Connection part
9. Pipe
10. Catch
11. Wheels
12. Recess
13. Front wheel
14. Thread collector
15. Boss

**[0007]** The flow of the debris sucked in together with air is guided towards the suction inlet port (4) of the vacuum cleaner by means of a guide (2) placed inside the brush (1). The guide (2) consists of symmetrical lateral edges (6) and a suction inlet port window (5) with an opening which matches with the suction inlet port (4). As the lateral edges (6) of the guide (2) are inclined at a certain degree, the losses that may occur at the flow region are minimized. The guide (2) is so placed along the brush (1) that its opening is at the base of the brush. The suction inlet port window (5) provided at the upper portion of the guide (2) overlaps with the suction inlet port (4) and it has a width that matches with the suction inlet port (4). Furthermore, pressure losses are avoided by preventing the dirt laden air from entering the undesired regions of the brush (1) by means of the guide (2). The lateral edges (6) of the guide (2) may also be bent in a convex form as well as in a concave form. It can also consist of straight lateral edges (6) with a certain slope.

**[0008]** A turbulence is created inside the guide (2) placed within the brush (1), when the flow reaches to extremely high speeds. A profile (3) is used in order to enhance the performance while directing the debris received in together with air towards the suction inlet port (4). An elliptical profile (3) to direct the flow coming from the front and back of the brush separately towards the suction inlet port (4) with a minimum loss, is placed along the guide in such a manner that it is centrally located in the guide (2). The length of the profile (3) is shorter than that of the guide (2) and the profile (3) is mounted in the recesses (12) provided on both sides of the guide (2) so that no gap is left between the profile (3) and the guide (2). A catch (10) is provided at the point of the profile which matches with the suction inlet port window (5), in order to facilitate the guiding of the debris laden air towards the suction inlet port (4) and to regulate the air flow at the suction inlet port (4) of the brush (1); the surface of which, facing the suction inlet port (4) is straight, whereas the other surface has a certain inclination. The said

profile (3) may be elliptical or can be circular or equilateral rectangular.

[0009] Decreases in pressure losses and in the level of airborne noise are observed by using a guide (2) and a profile (3), thus providing a homogeneous dust suction along the brush (1) as well as minimizing the pressure losses within the brush (1). Consequently, the losses in this part of the cleaner is decreased and efficiency is increased with the reduction of the pressure values created at the brush (1) and at the base of the brush (7).

### Claims

1. A vacuum cleaner brush (1) comprising a suction inlet port from which the debris is sucked in, together with air and characterized with a guide (2) placed inside the brush (1), that directs the debris towards the suction inlet port of the vacuum cleaner, the said guide (2) comprising symmetrical lateral edges (6), which are bent in a convex or in a concave form or which are straight inclined, the said guide (2) further comprising an upper portion with a suction inlet port window (5) being an opening with a width matching to that of the suction inlet port, the said guide (2) being placed along the brush (1) so that its opening lies at the brush base (7) and its suction inlet port window (5) located at the top, overlaps with the suction inlet port.
2. A vacuum cleaner brush as claimed in Claim 1, characterized with an elliptical profile (3) that directs the flow coming from the front and back of the brush separately towards the suction inlet port (4)-, being placed along the guide (2) in such a manner that it is located in the middle of the guide (2), and the length of which is shorter than that of the guide (2); and recesses (12) that are provided on both sides of the guide (2), in which the profile (3) is mounted so that no gap is left between the profile (3) and the guide (2).
3. A vacuum cleaner brush as claimed in claims 1 to 2, characterized with the elliptical profile (3) which is provided with a catch (10) at the point of the profile which matches with the suction inlet port window (5), in order to facilitate the guiding of the debris laden air towards the suction inlet port and to regulate the air flow at the suction inlet port of the brush (1); the surface of which, facing the suction inlet port is straight, whereas the other surface is inclined.
4. A vacuum cleaner brush as claimed in Claim 1, characterized with a profile (3) that is circular.
5. A vacuum cleaner brush as claimed in Claim 1, characterized with a profile (3) that is an equilateral rectangle.

### Patentansprüche

1. Staubsaugerbürste (1), die eine Saugeinlassmündung aufweist, von der Staub zusammen mit Luft angesaugt wird, **gekennzeichnet durch** eine Führung (2), die im Inneren der Bürste (1) angeordnet ist und den Staub zur Saugeinlassmündung des Staubsaugers leitet, wobei die Führung (2) symmetrische Seitenkanten (6) aufweist, die in einer konvexen oder in einer konkaven Form gebogen sind oder die geradlinig geneigt sind, wobei die Führung (2) ferner einen oberen Abschnitt mit einem Saugeinlassmündungsfenster (5) aufweist, das eine Öffnung mit einer Breite ist, die an jene der Saugeinlassmündung angepasst ist, wobei die Führung (2) längs der Bürste (1) so angeordnet ist, dass ihre Öffnung an der Bürstenbasis (7) angeordnet ist und ihr Saugeinlassmündungsfenster (5), das sich an der Oberseite befindet, mit der Saugeinlassmündung überlappt.
2. Staubsaugerbürste nach Anspruch 1, **gekennzeichnet durch** ein elliptisches Profil (3), das die Strömung, die von der Vorderseite und der Rückseite der Bürste kommt, getrennt zur Saugeinlassmündung (4) leitet und längs der Führung (2) angeordnet ist, derart, dass es sich in der Mitte der Führung (2) befindet, wobei seine Länge kleiner als jene der Führung (2) ist; und durch Aussparungen (12), die auf beiden Seiten der Führung (2) vorgesehen sind und in denen das Profil (3) so montiert ist, dass zwischen dem Profil (3) und der Führung (2) kein Spalt verbleibt.
3. Staubsaugerbürste nach den Ansprüchen 1 bis 2, **gekennzeichnet durch** das elliptische Profil (3), das mit einer Einfangvorrichtung (10) an jenem Punkt des Profils versehen ist, der mit dem Saugeinlassmündungsfenster (5) übereinstimmt, um die Führung der mit Staub angereicherten Luft zur Saugeinlassmündung zu erleichtern und um die Luftströmung an der Saugeinlassmündung der Bürste (1) zu regulieren; wobei ihre Oberfläche, die der Saugeinlassmündung zugewandt ist, geradlinig ist, während die andere Oberfläche geneigt ist.
4. Staubsaugerbürste nach Anspruch 1, **gekennzeichnet durch** ein Profil (3), das kreisförmig ist.
5. Staubsaugerbürste nach Anspruch 1, **gekennzeichnet durch** eine Profil (3), das ein gleichseitiges Rechteck ist.

### Revendications

1. Brosse d'aspirateur (1) comprenant un orifice d'entrée d'aspiration à partir duquel les débris sont as-

pirés, conjointement avec l'air et **caractérisée par** un guide (2) placé à l'intérieur de la brosse (1), qui dirige les débris vers l'orifice d'entrée d'aspiration de l'aspirateur, ledit guide (2) comprenant des bords latéraux symétriques (6), qui sont pliés selon une forme convexe ou une forme concave ou qui sont inclinés droits, ledit guide (2) comprenant en outre une partie supérieure avec une fenêtre d'orifice d'entrée d'aspiration (5) qui est une ouverture avec une largeur correspondant à celle de l'orifice d'entrée d'aspiration, ledit guide (2) étant placé le long de la brosse (1) de sorte que son ouverture se trouve au niveau de la base (7) de la brosse et sa fenêtre d'orifice d'entrée d'aspiration (5) positionnée au niveau de la partie supérieure, se chevauche avec l'orifice d'entrée d'aspiration.

2. Brosse d'aspirateur selon la revendication 1, **caractérisée par** un profil elliptique (3) qui dirige le flux venant de l'avant et de l'arrière de la brosse séparément vers l'orifice d'entrée d'aspiration (4), qui est placé le long du guide (2), de sorte qu'il est positionné au centre du guide (2), et dont la longueur est plus courte que celle du guide (2) ; et des évidements (12) qui sont prévus des deux côtés du guide (2), dans lequel le profil (3) est monté de sorte qu'il n'y ait aucun espace entre le profil (3) et le guide (2).
3. Brosse d'aspirateur selon les revendications 1 à 2, **caractérisée par** le profil elliptique (3) qui est prévu avec un dispositif de capture (10) au point du profil qui correspond à la fenêtre d'orifice d'entrée d'aspiration (5), afin de faciliter le guidage de l'air chargé de débris vers l'orifice d'entrée d'aspiration et de réguler le débit d'air à l'orifice d'entrée d'aspiration de la brosse (1) ; dont la surface, faisant face à l'orifice d'entrée d'aspiration, est droite, alors que l'autre surface est inclinée.
4. Brosse d'aspirateur selon la revendication 1, **caractérisée par** un profil (3) qui est circulaire.
5. Brosse d'aspirateur selon la revendication 1, **caractérisée par** un profil (3) qui est un rectangle équilatéral.

50

55

FIGURE 1

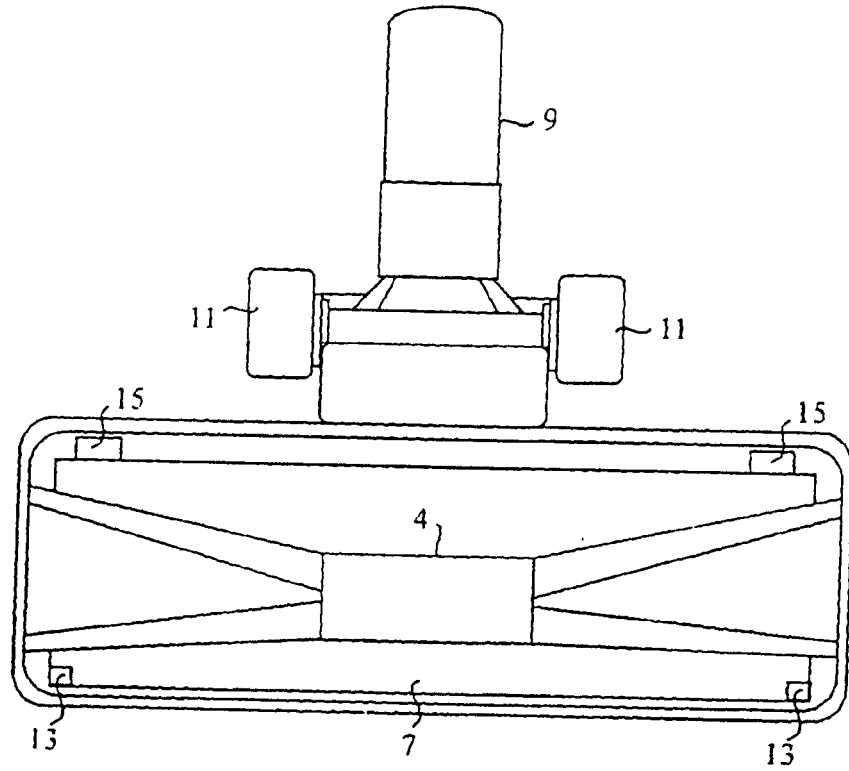

FIGURE 2

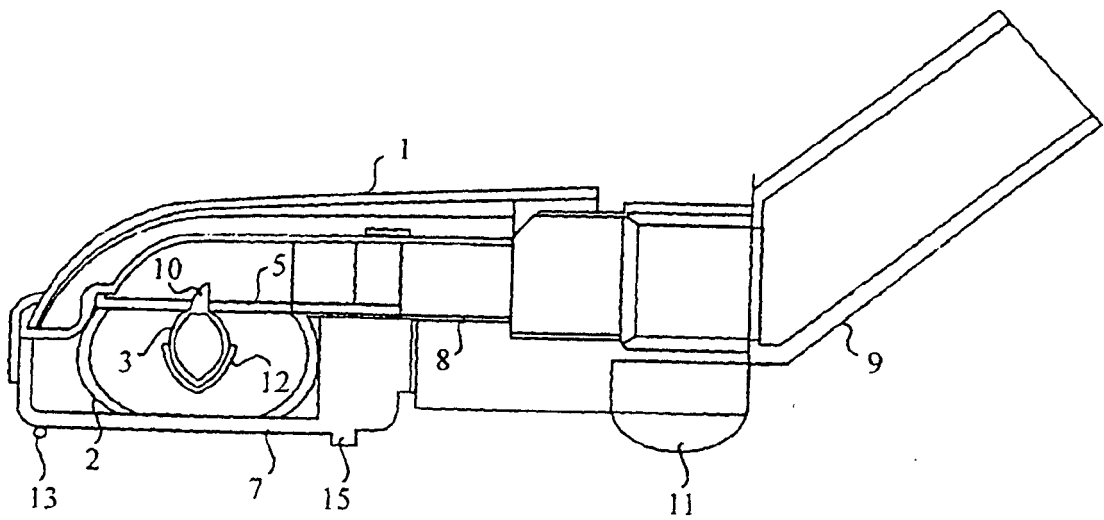

FIGURE 3

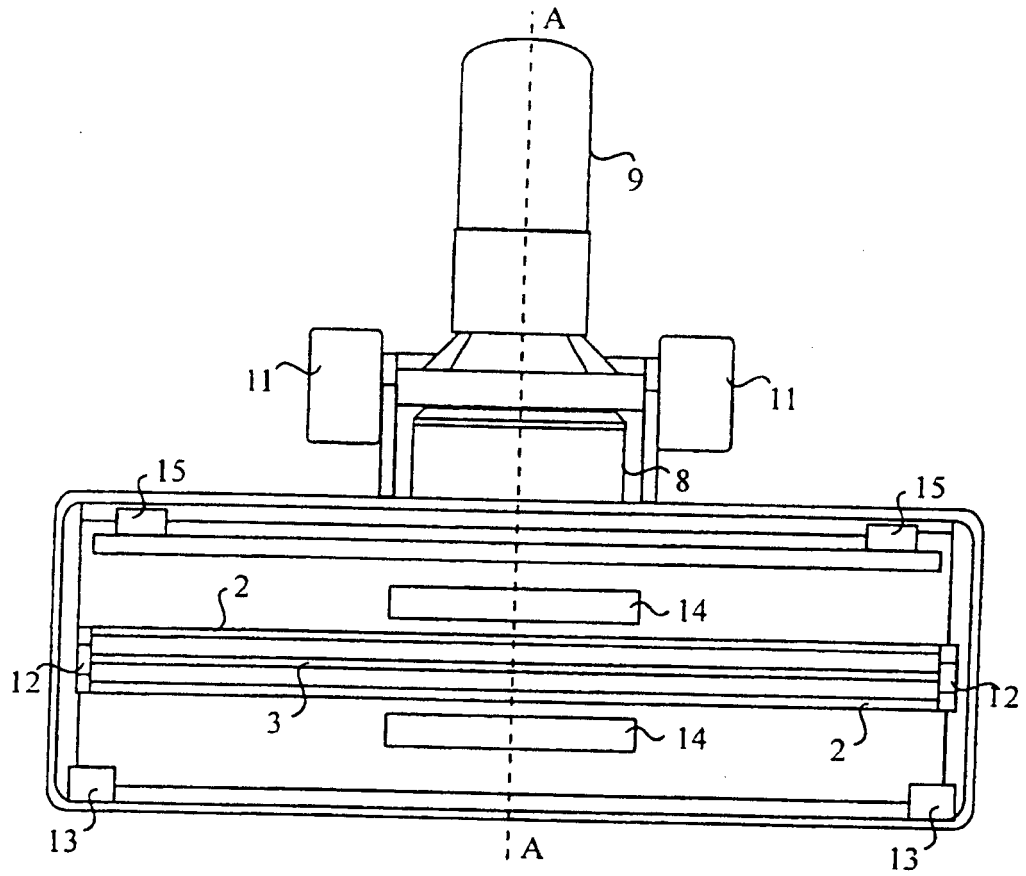
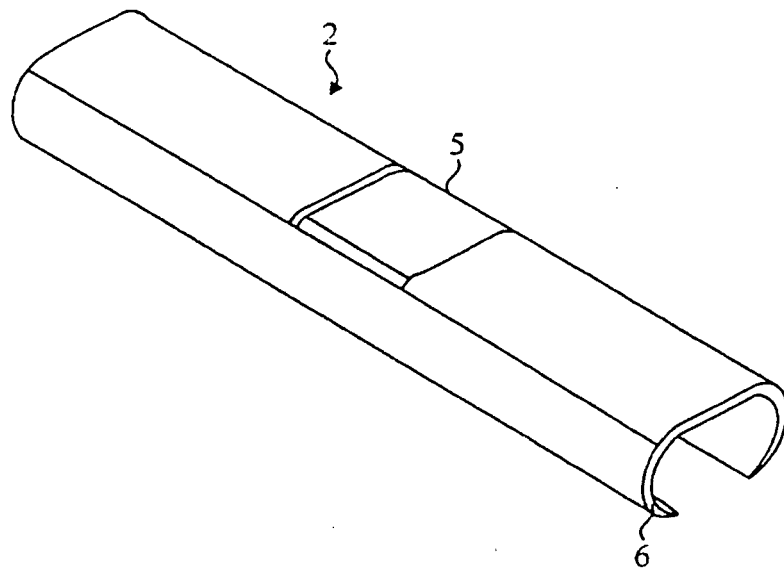

FIGURE 4



**REFERENCES CITED IN THE DESCRIPTION**

*This list of references cited by the applicant is for the reader's convenience only. It does not form part of the European patent document. Even though great care has been taken in compiling the references, errors or omissions cannot be excluded and the EPO disclaims all liability in this regard.*

**Patent documents cited in the description**

- US 4336628 A [0003]