



(11) **EP 1 277 887 B1**

(12) **EUROPEAN PATENT SPECIFICATION**

(45) Date of publication and mention of the grant of the patent:
27.08.2008 Bulletin 2008/35

(51) Int Cl.:
E02D 5/36 (2006.01) **E02D 5/66** (2006.01)
E02D 7/22 (2006.01) **E21B 7/26** (2006.01)
E21B 10/44 (2006.01) **E21B 10/62** (2006.01)

(21) Application number: **02291716.5**

(22) Date of filing: **09.07.2002**

(54) **Displacement drilling tool and equipment using said tool**

Verdrängerbohrer und Gerät, welches den Bohrer benutzt

Foret de déplacement et appareil utilisant ce foret

(84) Designated Contracting States:
**AT BE BG CH CY CZ DE DK EE ES FI FR GB GR
IE IT LI LU MC NL PT SE SK TR**

(30) Priority: **17.07.2001 GB 0117410**

(43) Date of publication of application:
22.01.2003 Bulletin 2003/04

(73) Proprietor: **COMPAGNIE DU SOL
92000 Nanterre (FR)**

(72) Inventor: **Stansfield, Lewis,
Compagnie du Sol
92000 Nanterre (FR)**

(74) Representative: **Dronne, Guy et al
Cabinet Beau de Loménie,
158, rue de l'Université
75340 Paris Cedex 07 (FR)**

(56) References cited:
EP-A- 0 588 143 WO-A-94/02687
GB-A- 2 316 700 GB-A- 2 329 204
US-A- 5 722 498 US-A- 6 033 152

EP 1 277 887 B1

Note: Within nine months of the publication of the mention of the grant of the European patent in the European Patent Bulletin, any person may give notice to the European Patent Office of opposition to that patent, in accordance with the Implementing Regulations. Notice of opposition shall not be deemed to have been filed until the opposition fee has been paid. (Art. 99(1) European Patent Convention).

Description

[0001] The present invention relates to a displacement drilling tool and to an equipment for making piles in the soil, said installation using said displacement drilling tool.

[0002] There are three most important categories of technique for making piles in the soil.

[0003] The first category is called "Driven piles". A pre-cast concrete pile is driven into the soil by a percussive hammer. This process has the advantage of improving compaction of the soil, therefore design rules can allow very favourable coefficients of safety. However, this type of pile is no longer accepted on many sites, since it creates very high noise levels and high levels of vibration in the soil that could cause damage to neighbouring structures.

[0004] The second category is called "Bored piles". According to this technique the soil is excavated by means of a bucket or auger, both of which are rotary types of boring equipment. The problem here is to avoid decompression of the soil, which decreases its bearing capacity and can cause settlements that may also be damaging to neighbouring structures. This technique is more environmentally friendly than driven piling since rotary drilling is less noisy and creates little or no vibration.

[0005] Finally the third category is called "Rotary displacement piles". The drilling equipment is designed to displace the soil horizontally and compact it around the sides of the hole during the drilling process. A minimum of soil waste is brought to the ground surface, and the increased density of the surrounding soil improves the bearing capacity of the pile.

[0006] The present invention relates to the third category.

[0007] When making a pile in the soil it is important to obtain good compaction of the wall of the borehole. It is also important to perform a good anchorage of the pile in the soil. To this purpose a helical groove can be provided in the wall of the bore. When concrete is injected in the bore, the concrete also fills the helical groove to form a concrete thread which ensures the anchorage of the pile. Another advantage of the helical thread is to allow a significant reduction of the required amount of concrete.

[0008] Drilling tools based on the rotary displacement technique are well known per se. For example US 6,033,152 and EP 0 693 158 describe two types of drilling tool performing a horizontal displacement of the soil during the drilling operation. Another disclosure of such a tool is WO 94/02687 A, as described in the preamble of claim 1.

[0009] However, the known displacement drilling tools have significant drawbacks especially regarding the quality of the concrete thread of the pile.

[0010] A first object of the present invention is to provide a displacement drilling tool which overcomes the drawbacks of the known drilling tools.

[0011] To achieve this object, according to the present

invention, the drilling tool comprises a stem having a tip, an upper end and a longitudinal axis, to be connected to at least one rotating follower tube, and a helical flight surrounding said stem, said drilling tool being characterised in that the external diameter of said stem decreases from the upper end to said tip, said helical flight has a substantially constant external diameter and in that it further comprises cutter means fixed to said helical flight close to said tip, said cutter means projecting outside said helical flight and extending along a direction substantially perpendicular to said longitudinal axis.

[0012] It will be understood that the tapered stem performs the horizontal displacement of the soil and the compaction of the wall of the bore during the downward displacement of the tool. During the upward displacement of the tool, the cutter means which projects outside the flight, produces the helical groove in the compacted wall of the bore.

[0013] Another object of the present invention is to provide an equipment for making piles in the soil.

[0014] The equipment comprises:

- a drilling tool;
- first motor means for rotating said drilling tool about its longitudinal axis;
- second motor means for vertically moving said drilling tool upwardly and downwardly;
- control means for applying control signals to said first and second motor means so that during the downward displacement, the drilling tool is rotated in a clockwise direction, and so that during the upward displacement the drilling tool is rotated in said clockwise direction with a predetermined rotation speed and said drilling tool is upwardly moved with a predetermined linear speed whereby the helical slot performed in the wall of the bore by said cutter means has a predetermined pitch.

[0015] It will be understood that the rotation speed and the upward displacement speed of the tool can be controlled independently. The pitch of the helical groove produced by the cutter means can be predetermined. Moreover this pitch can be varied with depth.

[0016] Other features and advantages of the present invention will appear better on reading the following description of several embodiments of the invention given by way of non-limiting examples.

[0017] The description refers to the accompanying figures in which:

Figure 1A is a general view of a drilling tool mounted at the lower end of a rotating follower tube;
 Figure 1B is a view of the lower part of the drilling tool, looking from the rear of Figure 1A;
 Figure 1C is a sectional view through the drilling tool, looking down on line A-A;
 Figure 2 is a perspective view of the drilling tool;
 Figure 3 shows in more details the lower part of the

drilling tool;

Figure 4 shows the two modes of action of the thread cutter of the tool;

Figure 5 shows in vertical section the profile of a portion of a pile made with the drilling tool; and

Figure 6 is a schematic view of a drilling equipment which uses the drilling tool of Figures 1 to 3.

[0018] Referring firstly to Figures 1A to 3, the rotary displacement drilling tool 10 will be described.

[0019] Broadly speaking, the tool 10 consists of an auger head having particular geometrical features.

[0020] The tool 10 comprises a hollow stem 12 provided with an axial passage 14 for delivering concrete, a tip 16 and an upper connecting end 18. The stem 12 is tapered and the external diameter D1 of the stem close to the tip 16 is inferior to the external diameter D2 of the stem at its upper end 18. The total length of the tool is equal to L1.

[0021] In a preferred embodiment, D1 = 160 mm; D2 = 273 mm; and L1 = 1780 mm.

[0022] The tool 10 further comprises a helical flight 20 which extends along the whole length of the stem 12. The external diameter D3 of the flight is constant. Preferably, D3 = 330 mm. Preferably also, the pitch of the helical flight is substantially constant and the external diameter D3 of the flight is substantially equal to the greater external diameter D2 of the stem.

[0023] According to a main feature of the invention, the flight 20 is provided with a cutting blade 24, visible in Figures 1B, 1C, 2 and 3. The cutting blade 24 is held at a fixed angle α in a blade holder 26 near the base of the auger close to the tip 16 of the tool. The cutting blade 24 projects outside the flight 20 and extends in a direction substantially perpendicular to the axis XX' of the stem 12. In a preferred embodiment, the length L2 of the blade is equal to 60 to 85 mm, its thickness e is equal to 25 mm, and an angle α is equal to 15 degrees.

[0024] At its lower end, the flight 20 is provided with a blade 28, which is held at a steep angle in a blade holder 21. A flange 22' forms a vertical skirt to reinforce the blade holder 21 and assists in maintaining correct alignment of the drilling tool when it first enters the soil.

[0025] Preferably, the tool 10 further comprises a follower tube 32 in one or more pieces connected to each other and to the upper end 18 of the stem of the auger. The follower tube 32 has the same diameter D2 as the greater diameter of the tapered stem of the tool 12. It may be plain, or may have small flights of similar external diameter to those of the auger head, as shown in Figure 1A.

[0026] In preferred embodiments, the follower tube is 12 metres or 18 metres long, comprising 2 or 3 pieces, each piece being 6 metres long.

[0027] The follower tube 32 performs two functions. It allows the extension of the length of the drilling tool to enable it to bore to the required depth, and it transmits the rotary action of the drilling head of the equipment or

rig. The follower tube 32 has no flight.

[0028] The modes of action of the cutting blade 24 will be described with reference to Figure 4.

[0029] During its downward displacement, the tool is rotated in a clockwise direction. The cutting blade 24 is designed to provide little resistance to penetration of the tool cutting only a thin slot 40 in the wall 42 of the bore 44. The section of the slot has the same size as the section of the blade. For example, 25 mm x 60 to 85 mm. This slot is closed when the soil is displaced by the tapered stem 12 of the tool.

[0030] During its extraction, the tool 10 is still rotated in a clockwise direction and the required lifting force is applied to the tool. In this case, the cutting blade 24 cuts a trapezoidal helical slot 46 in the wall 42 of the bore 44. The trapezoidal slot 46 and the bore 44 are filled with concrete, pumped through the axial passage 14 and delivered by the opened lower end of the stem of the tool, as the drilling tool is being extracted from the ground.

[0031] In figure 2, the cutting blade 24 is disposed at an angle equal to 180 degrees with respect to the terminal blade 28. Preferably, this angle is reduced to about 90 degrees, whereby the cutting blade 24 is still closer to the tip 16 of the tool. In this preferred embodiment, the cutting blade 24 is closer to the opened end of the stem of the tool through which the concrete is delivered. As a result, the filling of the slot made by the cutting blade 24 is still improved.

[0032] Referring now to Figure 6, the drilling equipment using the tool 10 will be described in details.

[0033] The equipment shown in Figure 6 comprises a piling rig 50 provided with a vertical mast 52. A trolley 54 is moved along the mast 52 by means of a cable 56 driven by a first motor 58. The trolley 54 supports a rotary drive box 60. The rotary drive box is equipped with a second motor 62 to rotate the follower tube 32. As already explained, the drilling tool 10 shown in Figures 1A to 3 is fixed to the lower end of the follower tube 32.

[0034] The equipment further comprises a concrete pump 64. The pump is connected to the upper end of the follower tube by means of a concrete delivery pipe 66 and a rotary sealing joint 68.

[0035] In order to control the operation of the equipment, it further comprises a first speed transducer 72 to measure the vertical displacement speed of the tool 10 and a second speed transducer 74 to measure the rotation speed of the tool 10. A control unit 76 receives the signals delivered by the transducers 72 and 74 and emits speed control signals towards the motors 58 and 62. Moreover, the concrete delivery pipe 66 for delivering the concrete is equipped with transducers 78 and 80 to measure the flow rate of concrete and the concrete pressure.

[0036] According to an important feature of the equipment, the uplift speed of the tool 10 and the rotation speed of the tool can be controlled independently by the control unit 76. Consequently, it is possible to obtain a helical slot in the wall of the bore which has a variable pitch, and a pile having a helical thread with a variable or adjustable

pitch.

[0037] The ability to adjust or vary the pitch of the helical thread of the pile provides many advantages.

- The ability to match the shear resistance of the concrete threads to the shear strength of the soil, in order to ensure that premature failure does not occur in the concrete when piles are heavily loaded in dense granular soil or stiff clay. The shear strength of the soil may be determined by means of soil testing prior to pile installation, or by analysis of drilling parameters recorded by instrumentation on the rig when the piles are being installed.
- The ability to limit the bearing stress between the concrete threads and the soil to ensure that premature failure does not occur as a result of the soil between the threads being over-stressed.
- The ability to vary the profile of the pile with depth, for example:
 - short pitch in lower layers of soil from which the pile derives its bearing capacity (anchor zone)
 - extraction of the drilling tool without rotation through compressible upper layers of soil to produce a section of pile shaft with no thread, thereby reducing negative shaft friction.

[0038] Figure 5 shows a portion of a pile obtained by using the equipment as shown in Figure 6. This figure shows the concrete pile itself 86, the diameter of which is defined by the external diameter of the flight and the helical thread 88 corresponding to the rotation of the cutting blade 24 during the upward displacement of the tool (see Figure 4).

[0039] The preferred way of operating of the drilling equipment is as follows:

- The rig is set up at the pile position and a disposable end cap (not shown in the figures) is fitted to the bottom of the auger head.
- The bore is drilled to the required depth, allowing the drilling tool to pull itself into the ground.
- Upon reaching the required depth, the drilling tool is rotated in a clockwise direction (the same as for boring) to reduce the friction between the drilling tool and the soil.
- When concreting is about to commence, the drilling tool is lifted 100 mm to allow the end cap to be released from the auger head.
- Concrete is pumped through the hollow stem 14 of the drilling tool until the pressure at the top of the follower tube 32 reaches 2 bars. The drilling tool is rotated twice in a clockwise direction while allowing it to bore back down to the original depth. This will ensure that any loose soil at the bottom of the bore is removed and the tip of the auger head is completely immersed in concrete.
- The rotation of the drilling tool is continued in a clock-

wise direction and lifting is started. The concrete pressure will increase for a very short time to about 10 or 20 bars before the drilling tool is lifted. The concrete pump operator should keep this brief pressure increase under control to ensure that the concrete delivery pipes do not become blocked.

- The drilling tool is lifted 300 mm for each rotation to form a screw thread with a pitch of 300 mm around the outside of the pile. The amount of lift can be varied to produce screw threads of different pitch. The concrete pressure at the top of the follower tube should be maintained between 0.5 and 2.0 bars during this operation. The lifting speed of the drilling tool must be synchronised with its rotation speed by the rig operator to form a screw thread with the required pitch. The concrete pressure must be controlled from the concrete pump.
- Finally, immediately upon completion of concreting, all loose soil is removed from the top of the pile and the required reinforcement is inserted.

[0040] The displacement drilling tool and the drilling equipment according to the invention has many advantages as compared with the known devices.

[0041] The making of the pile requires less concrete and produces very little spoil.

[0042] The torque required to screw the drilling tool into the ground is less than required by the known similar tools.

Claims

1. A drilling tool (32) to make piles in the soil comprising a stem having a tip, an upper end and a longitudinal axis (x) to be connected to least one rotating follower tube, and a helical flight surrounding said stem (18), said flight being provided with cutter means (28), said drilling tool being **characterised in that** the external diameter of said stem decreases from the upper end to said tip, for compacting the wall of the bore formed by said tool, said helical flight has a substantially constant external diameter and **in that** said cutter means (28) are fixed to said helical flight (20) close to said tip, said cutter means projecting outside said helical flight and extending along a fixed direction substantially perpendicular to said longitudinal axis for producing a helical groove within said compacted wall.
2. A drilling tool according to claim 1, **characterised in that** said stem (18) contains an axial passage (14) for delivering concrete and **in that** it further comprises a movable cap adapted to close the lower end of said axial passage.
3. A drilling tool according to claim 1 or 2, **characterised in that** said helical flight (20) has a pitch which

is substantially constant.

4. A drilling tool according to anyone of the preceding claims, **characterised in that** the external diameter of the flight (20) is substantially equal to the greatest diameter of the tapered stem. 5
5. A drilling tool according to anyone of claims 1 to 4, **characterised in that** it further comprises at least one follower tube without a flight (20), said follower tube having substantially the same diameter as the upper end of the stem. 10
6. A drilling tool according to any one of claims 1 to 5 **characterised in that** said cutter means (28) are disposed at an angle not greater than 180 said cutter disposed at an angle not greater than 180 degrees with respect to the lower end of the flight. 15
7. An equipment for making piles in the soil, **characterised in that** it comprises: 20

a drilling tool according to anyone of claims 1 to 5;

- first motor means for rotating said drilling tool about its longitudinal axis; 25

- second motor means for vertically moving said drilling tool upwardly and downwardly;

- control means for applying control signals to said first and second motor means so that during the downward displacement, the drilling tool is rotated in a clockwise direction, and so that during the upward displacement the drilling tool (32) is also rotated in said clockwise direction with a predetermined rotation speed and said drilling tool is upwardly moved with a predetermined linear speed whereby the helical slot performed in the wall of the bore by said cutter means has a predetermined pitch. 30

8. An equipment according to claim 6, **characterised in that** said drilling tool further comprises a movable cap adapted to close the lower end of the axial passage (14) in the stem of the tool and **in that** it further comprises means to deliver concrete to said axial passage. 35

Patentansprüche

1. Ein Bohrgerät (32), um Pfosten in die Erde zu bohren, das einen Vorbau mit einer Spitze umfasst, ein oberes Ende und eine Längsachse (x) zum Verbinden an wenigstens einen drehenden Druckkolbenkanal und einen spiralförmigen Gewindegang, der den Vorbau (18) umgibt, der Gewindegang ist mit Fräsmessern (28) ausgestattet, das Bohrgerät ist **dadurch gekennzeichnet, dass** der Außendurch- 50

messer des Vorbaus vom oberen Ende zur Spitze hin abnimmt, um die Wandung der Bohrung zu verdichten, die von diesem Gerät gebildet wird, der spiralförmige Gewindegang hat einen im Wesentlichen konstanten Außendurchmesser und die Fräsmesser (28) sind in der Nähe der Spitze an den spiralförmigen Gewindegang befestigt, die Fräsmesser (28) ragen außerhalb des spiralförmigen Gewindegangs (20) heraus und verlängern entlang einer Achse in festgelegter Richtung im Wesentlichen senkrecht zur Längsachse zur Erzielung einer spiralförmiger Nut innerhalb der verdichteten Wandung.

2. Ein Bohrgerät nach Anspruch 1, **dadurch gekennzeichnet, dass** der Vorbau (18) einen achsenförmigen Durchgang (14) hat um Beton zu liefern und weiterhin **dadurch**, dass es eine bewegliche Abdeckung umfasst, eingestellt um die niederen Enden des achsenförmigen Durchgangs zu schließen.
3. Ein Bohrgerät nach einem der Ansprüche 1 bis 2, **dadurch gekennzeichnet, dass** der spiralförmige Gewindegang (20) eine Schraubensteigung hat, die im Wesentlichen konstant ist.
4. Ein Bohrgerät nach allen vorausgehenden Ansprüchen, **dadurch gekennzeichnet, dass** der Außendurchmesser des Gewindegangs (20) im Wesentlichen gleich groß ist, wie der größte Durchmesser des Kegelvorbau.
5. Ein Bohrgerät nach einem der Ansprüche 1 bis 4, **dadurch gekennzeichnet, dass** es weiterhin mindestens einen Druckkolbenkanal ohne einen Gewindegang (20) umfasst, der Gewindegang hat im Wesentlichen denselben
6. Ein Bohrgerät nach einem der Ansprüche 1 bis 5, **dadurch gekennzeichnet, dass** die Fräsmesser (28) in einem Winkel, der, in Bezug auf das niederste Ende des Gewindegangs, nicht größer als 180 Grad ist, angeordnet sind.
7. Ein Gerät um Pfosten in die Erde zu bohren, **dadurch gekennzeichnet, dass** es 45

- ein Bohrgerät gemäß allen Ansprüche von 1 bis 5

- erste Motorenmittel zum Drehen des Bohrgeräts um die Längsachse

- zweite Motorenmittel zum vertikalen hoch- und herunturbewegen des Bohrgeräts;

- Kontrollmittel um Kontrollsignale an den ersten und zweiten Motorenmitteln zu verwenden, so dass sich das Bohrgerät (32) auch während der Aufwärtsverlagerung mit einer vorherbestimmten Drehgeschwindigkeit im Uhrzeigersinn dreht und dieses Bohrgerät bewegt sich mit ei-

ner vorherbestimmten Lineargeschwindigkeit nach oben, wobei die spiralförmig Aussparung, die in der Wandung der Bohrung der Fräsmesser ausgebildet ist, eine vorherbestimmte Schraubensteigung hat,

umfasst.

8. Ein Gerät nach Anspruch 6, **dadurch gekennzeichnet, dass** das Bohrgerät weiterhin eine bewegliche Abdeckung umfasst, eingestellt um das niedere Ende des achsenförmigen Durchgangs (14) am Vorbau des Geräts zu schließen und dass es weiterhin Geräte umfasst um an den achsenförmigen Durchgang Beton zu liefern.

Revendications

1. Outil de forage (32) pour réaliser des pieux dans le sol, comprenant une tige ayant un embout, une extrémité supérieure et un axe longitudinal (x), qu'il s'agit de connecter à au moins un tube suiveur en rotation, et un filet hélicoïdal entourant ladite tige (18), ledit filet étant pourvu de moyens de coupe (28), ledit outil de forage étant **caractérise en ce que** le diamètre extérieur de ladite lige diminue depuis l'extrémité supérieure jusqu'audit embout, pour compacter la paroi du trou formé par ledit outil, ledit filet hélicoïdal ayant un diamètre extérieur sensiblement constant, et **en ce que** lesdits moyens de coupe (28) sont fixées maudit filet hélicoïdal (20) à proximité dudit embout, lesdits moyens de coupe se projetant vers l'extérieur dudit filet hélicoïdal et s'étendant le long d'une direction fixe sensiblement perpendiculaire audit axe longitudinal pour produire une rainure hélicoïdale à l'intérieur de ladite paroi compactée.
2. Outil de forage selon la revendication 1, **caractérisé en ce que** ladite tige (18) contient un passage axial (14) pour la fourniture de béton, et **en ce qu'**il comprend en outre un capuchon mobile adapté à fermer l'extrémité inférieure duit passage axial.
3. Outil de forage salon la revendication 1 ou 2, **caractérisé en ce que** ledit filet hélicoïdal (20) a un pas qui est sensiblement constant.
4. Outil de forage salon l'une quelconque des revendications précédentes, **caractérisé en ce que** le diamètre externe du filet (20) est sensiblement égal au plus grand diamètre de la tige effilée.
5. Outil de forage selon l'une quelconque des revendications 1 à 4, **caractérisé en ce qu'**il comprend en outre au moins un tube suiveur dépourvu de filet (20), ledit tube suiveur ayant sensiblement le même diamètre que l'extrémité supérieure de la tige.
6. Outil de forage selon l'une quelconque des revendications 1 à 5, **caractérisé en ce que** lesdits moyens de coupe (28) sont disposés sous un angle qui ne dépasse pas 1800 par rapport à l'extrémité inférieur du filet.
7. Équipement pour réaliser des pieux dans le sol, **caractérisé en ce qu'**il comprend :
 - un outil de forage selon l'une quelconque des revendications 1 à 5 ;
 - des premiers moyens moteurs pour faire tourner ledit outil de forage autour de son axe longitudinal ;
 - des seconds moyens moteurs pour déplacer verticalement ledit outil de forage vers le haut et vers le bas ;
 - des moyens de commande pour appliquer des signaux de commande auxdits premiers moyens moteurs et auxdits seconds moyens moteurs de sorte que pendant le déglacement descendant, l'outil de forage est mis en rotation dans le sens des aiguilles d'une montre, et de sorte que pendant le déplacement montant, l'outil de forage (32) est aussi mis en rotation dans le sens des aiguilles d'une montre avec une vitesse de rotation prédéterminée, et ledit outil de forage est déplacé vers le haut avec une vitesse linéaire prédéterminée, grâce à quoi la rainure hélicoïdale réalisée dans la paroi du trou par lesdits moyens de coupe a un pas prédéterminé.
8. Équipement selon la revendication 6, **caractérisé en ce que** ledit outil de forage comprend en outre un capuchon mobile adapté à fermer l'extrémité inférieure du passage axial (14) dans la tige de l'outil, et **en ce qu'**il comprend en outre des moyens pour fournir du béton dudit passage axial.

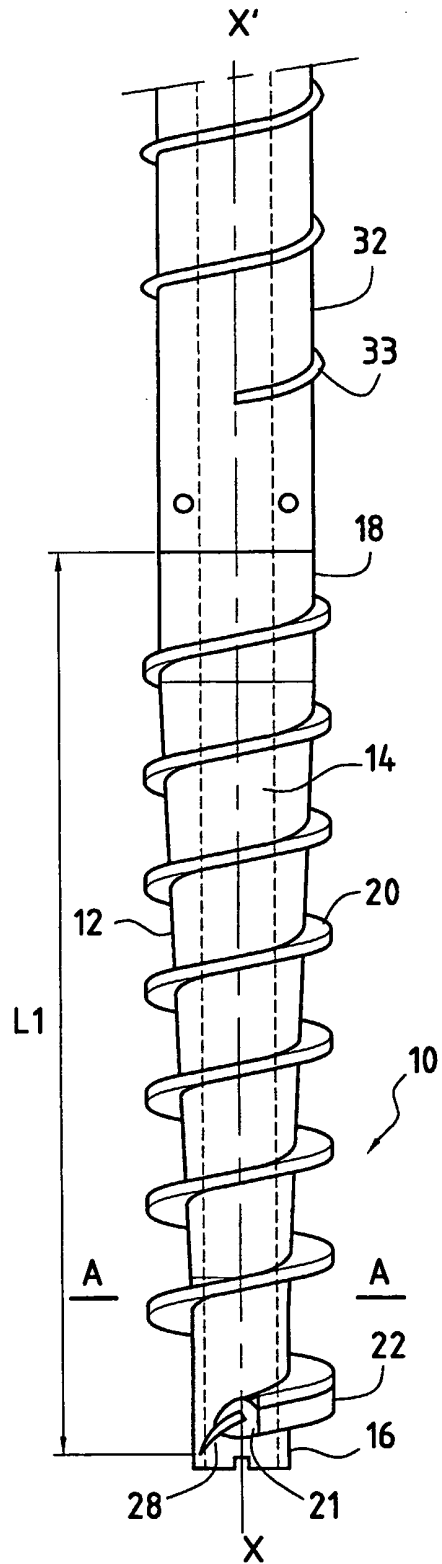
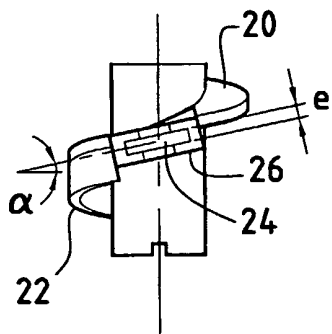
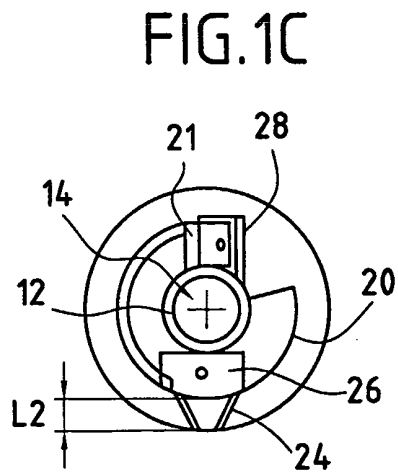

FIG.1A

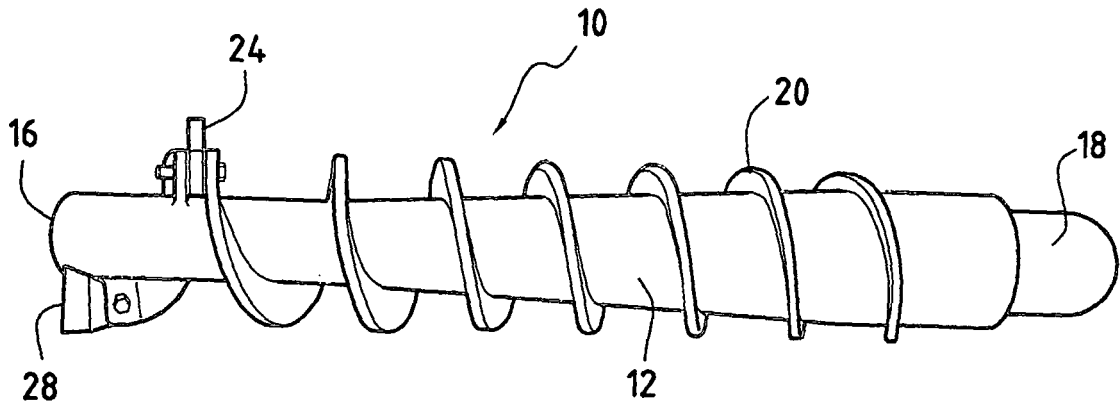

FIG. 2

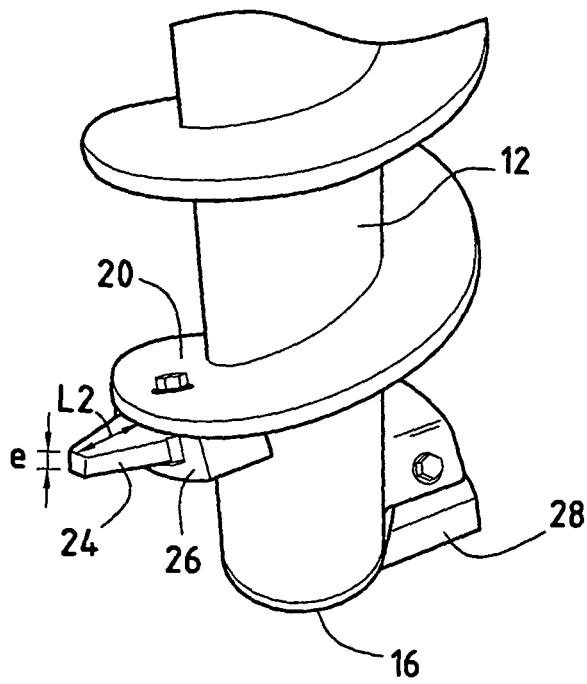

FIG. 3

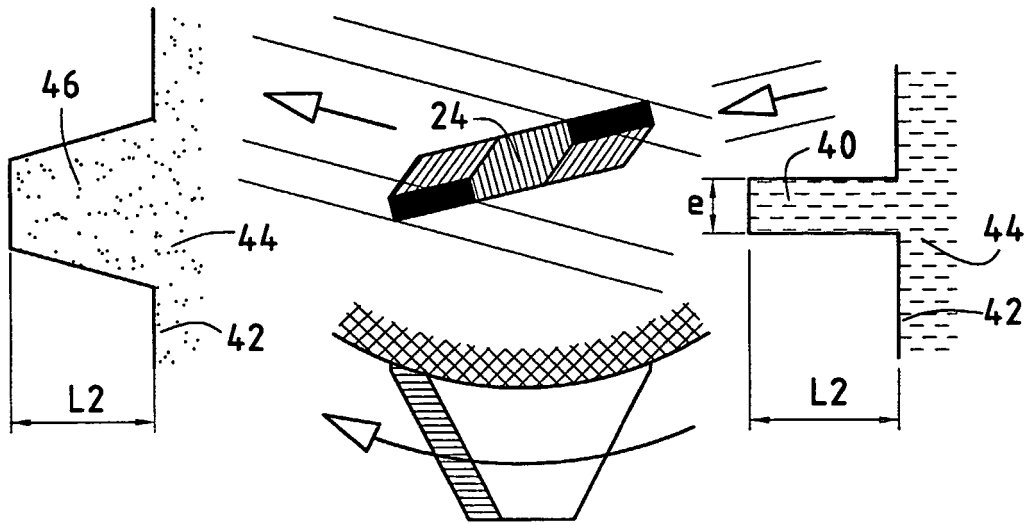

FIG. 4

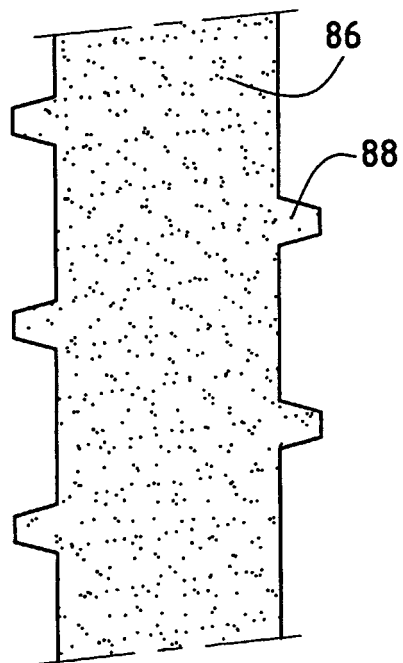

FIG. 5

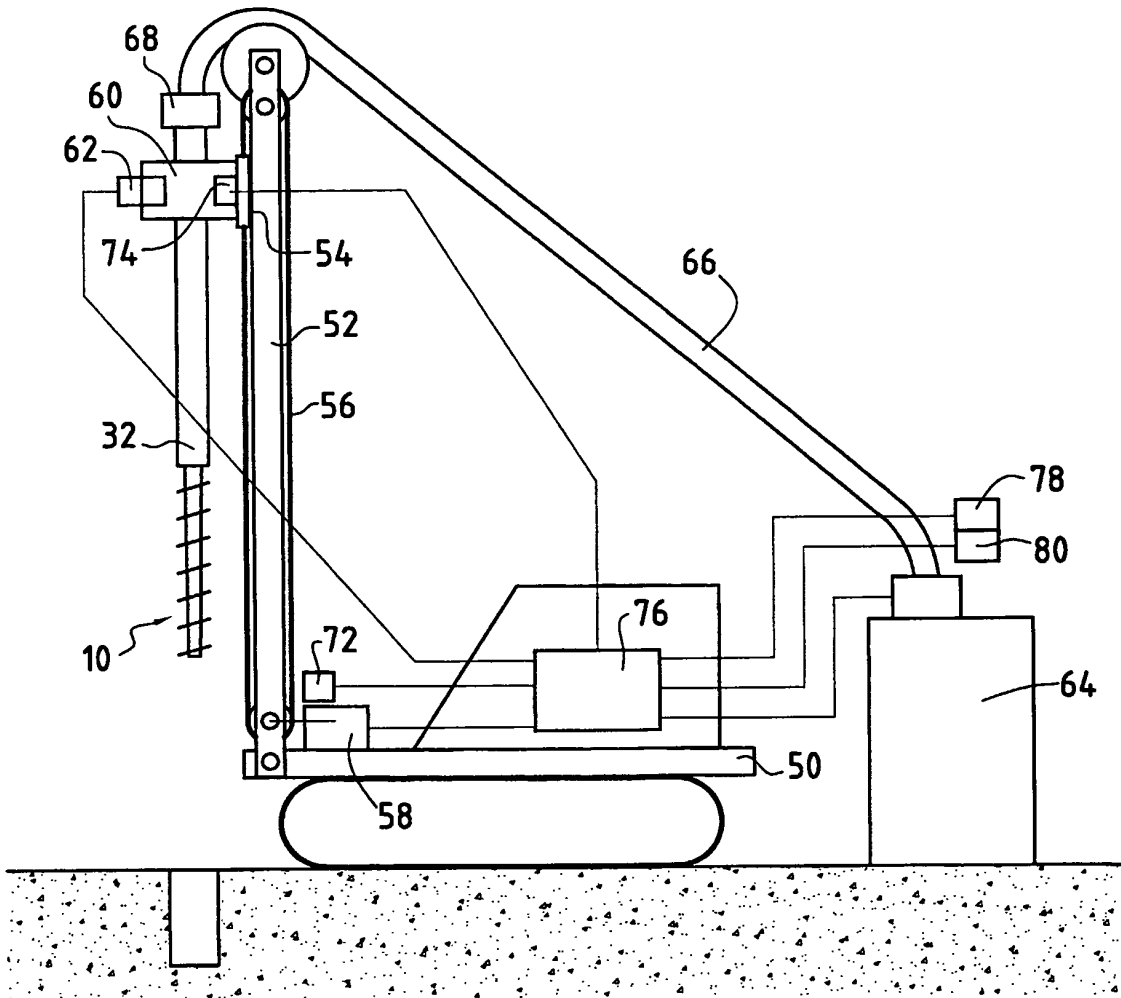

FIG.6

REFERENCES CITED IN THE DESCRIPTION

This list of references cited by the applicant is for the reader's convenience only. It does not form part of the European patent document. Even though great care has been taken in compiling the references, errors or omissions cannot be excluded and the EPO disclaims all liability in this regard.

Patent documents cited in the description

- US 6033152 A [0008]
- EP 0693158 A [0008]
- WO 9402687 A [0008]