



(11) **EP 1 277 900 B1**

(12) **EUROPEAN PATENT SPECIFICATION**

(45) Date of publication and mention of the grant of the patent:
03.01.2007 Bulletin 2007/01

(51) Int Cl.:
E05B 7/00 ^(2006.01) **E05B 3/00** ^(2006.01)
E05B 65/20 ^(2006.01)

(21) Application number: **01830488.1**

(22) Date of filing: **20.07.2001**

(54) **Vehicle door handle**

Türgriff für ein Kraftfahrzeug

Poignée de porte pour véhicule

(84) Designated Contracting States:
AT BE CH CY DE DK ES FI FR GB GR IE IT LI LU MC NL PT SE TR

(43) Date of publication of application:
22.01.2003 Bulletin 2003/04

(73) Proprietor: **Valeo Sicurezza Abitacolo S.p.A.**
10026 Santena (IT)

(72) Inventors:
• **Brescia, Fabio**
94042 Créteil Cedex (FR)

• **Villagrasa, Victor**
94042 Créteil Cedex (FR)

(74) Representative: **Rosolen-Delarue, Katell**
Valeo Sécurité Habitacle,
Service Propriété Industrielle,
42, rue Le Corbusier - Europarc
94042 Creteil Cedex (FR)

(56) References cited:
EP-A- 0 646 688 **DE-A- 2 026 552**
DE-A- 2 612 237 **DE-A- 3 030 519**
US-A- 5 974 842

EP 1 277 900 B1

Note: Within nine months from the publication of the mention of the grant of the European patent, any person may give notice to the European Patent Office of opposition to the European patent granted. Notice of opposition shall be filed in a written reasoned statement. It shall not be deemed to have been filed until the opposition fee has been paid. (Art. 99(1) European Patent Convention).

Description

[0001] The present invention relates to a vehicle door handle, and in particular to a handle comprising a frame, which is housable inside and fixedly connectable to the door.

[0002] Known frames comprise a hollow end portion housing a lock cylinder fitted directly to the frame to release and engage a lock on the door by means of a key.

[0003] Known handles of the type described above are unsatisfactory by failing to ensure against break-in and theft of the vehicle.

[0004] Other known handles, as the one presented in document EP-A-0646688, which corresponds to the preamble of claim 1, comprise a metallic supporting element holding a lock cylinder in plastic frame. The supporting element is fixed to the plastic frame by means of a local fixing ring or plate.

[0005] In these known devices the connection of the lock cylinder to the known frame of the type described above even if it has been enhanced, is fairly weak, so that, by forcing the handle from outside the vehicle by means of a tool, such as a screwdriver or lever, the lock cylinder can be rotated with respect to the frame or withdrawn fairly easily to release the lock without the key.

[0006] It is the object of the present invention to provide a vehicle door handle designed to solve the aforementioned drawbacks in a straightforward, low-cost manner, while at the same time still being lightweight and cheap to produce.

[0007] According to the present invention, there is provided a handle for a vehicle door as claimed in claim 1.

[0008] A non-limiting embodiment of the invention will be described by way of example with reference to the accompanying drawings, in which:

Figure 1 shows a schematic section of a preferred embodiment of the vehicle door handle according to the present invention;

Figure 2 shows a larger-scale view in perspective of a component part of the Figure 1 handle;

Figure 3 shows a schematic section along line III-III in Figure 1;

Figure 4 shows the same view as, and a larger-scale detail, with parts removed for clarity, of Figure 1.

[0009] Number 1 in Figure 1 indicates a handle for a door 2 (shown partly) of a vehicle, in particular a motor vehicle.

[0010] Door 2 comprises an outer body 3, in turn comprising a concave intermediate portion 5, and two portions 6 and 7, which are located on opposite sides of portion 5 in a direction A parallel, in use, to a horizontal longitudinal direction of the vehicle, and have respective openings 8 and 9.

[0011] The edge of each opening 8, 9 is fitted with an annular sealing member 8a, 9a for ensuring, in use, fluidtight sealing of handle 1 through opening 8, 9.

[0012] With reference to the accompanying drawings, handle 1 is elongated parallel to direction A, and comprises a fastening frame 10, which is located inside door 2, is fixedly connected to door 2 in known manner not described in detail, and is formed in one piece from plastic material.

[0013] Frame 10 comprises an intermediate portion 11 facing portion 5; and two hollow, opposite end portions 12 and 13 adjacent to portions 6 and 7 respectively, and of which portion 13 defines a through cavity 15 at opening 9.

[0014] With reference to Figures 1 and 3, portion 13 has a flat annular surface 19 facing body 3 and having a seat 20 formed adjacent to intermediate portion 11, and comprises two facing lateral walls 21, which extend perpendicularly to surface 19 and parallel to direction A, and are connected to each other at the end of frame 10 by a transverse portion 25.

[0015] As shown in Figure 1, handle 1 also comprises a known lever 35 outside door 2, and which has, at the ends, two integral arms 36 and 37 extending through openings 8 and 9 respectively. Arm 36 is fitted to portion 12 to allow lever 35, when operated manually by a user, to rotate, about an axis 38 perpendicular to direction A, between a rest position and a work position in which arm 37 releases, in known manner not shown, a lock (not shown) on door 2.

[0016] With reference to Figures 1, 3 and 4, the lock is released and engaged by means of a known lock cylinder 40 (shown schematically) extending through cavity 15 along an axis 41 perpendicular to direction A and to axis 38, and for receiving a key (not shown).

[0017] Lock cylinder 40 is connected to frame 10 by a connecting assembly 44 comprising a body 45, which is made of stronger material than frame 10, preferably metal, and in turn comprises a tubular portion 46 housing and fixedly connected to lock cylinder 40.

[0018] Body 45 also comprises a nut screw 47 projecting from portion 46 and facing portion 25; and a guard wall 48 extending about portion 46 on the outside of door 2. Wall 48 has a hole 49 permitting insertion of the key inside lock cylinder 40, and which is defined by an annular projection 49a defining a shoulder resting axially on lock cylinder 40.

[0019] Body 45 has a cap 50, which clicks onto wall 48.

[0020] With reference to the accompanying drawings, assembly 44 also comprises a supporting body 51 also made of stronger material than frame 10, and preferably of a metal alloy known commercially as "ZAMAK".

[0021] Body 51 comprises a front wall 52, which is interposed between surface 19 and body 3, rests on surface 19 itself, and defines an opening 53 formed at opening 9 and cavity 15 and closed partly by wall 48. Body 51 also comprises a lateral wall 54, which extends perpendicularly to wall 52, is fitted about portion 13, and rests on walls 21 and portion 25 to retain body 51 to frame 10 angularly about axis 41. Body 51 is retained axially to portion 13 by releasable retaining devices 55 defined, in

particular, by two lateral seats 56 (Figure 3) into which click respective elastic appendixes 57 integral with walls 21, and by an end tongue 58 which clicks into seat 20.

[0022] Tongue 58 is retained on portion 7 of body 3 by member 9a, which comprises an appendix 61 extending through opening 53 and engaging tongue 58.

[0023] On the opposite side to tongue 58 in direction A, wall 54 comprises a portion 62, which rests against portion 25 and has an integral projection 63 facing wall 52 and defining, together with wall 52, a seat 65 engaged by portion 25. Projection 63 defines a through hole 67 coaxial with nut screw 47 and fitted through with a screw 69, the end of which is screwed inside nut screw 47 to lock bodies 45 and 51 to each other.

[0024] With reference to Figures 1 and 2, body 51 comprises two plates 70, which are reinforced with ribs, project in diverging directions from the opposite side to tongue 58 to form an extension of wall 52, and are positioned facing and detached from body 3.

[0025] To fit handle 1 to door 2, body 51 is fitted to portion 13 by first inserting portion 25 inside seat 65 and then rotating body 51 anticlockwise, in Figures 1 and 4, to click appendixes 57 inside seats 56, and tongue 58 inside seat 20.

[0026] After positioning frame 10 inside door 2, members 8a, 9a are fitted to the edges of openings 8, 9: appendix 61 is hooked onto body 51; and lever 35 is then fitted to frame 10, working from outside door 2.

[0027] After fitting lock cylinder 40 to body 45, body 45 is inserted through opening 9 into cavity 15; wall 48 is positioned against member 9a to partly close openings 9 and 53; and bodies 45 and 51 are locked to each other by tightening screw 69 from inside door 2.

[0028] In use, bodies 45 and 51 therefore safeguard handle 1 against any attempt to break into the vehicle, by being stronger than frame 10, by supporting lock cylinder 40, and by being locked to each other and to frame 10.

[0029] As such, bodies 45 and 51 prevent lock cylinder 40 from rotating about axis 41 with respect to frame 10, or being extracted from frame 10.

[0030] Walls 52 and 54 protect portion 13 against scratching or breakage using tools such as a screwdriver, punch, pliers or lever; wall 48 acts as a barrier to prevent insertion of such tools through openings 9, 53; and annular projection 49a prevents lock cylinder 40 from being withdrawn axially.

[0031] Any attempt to lever body 51 about axes crosswise to axis 41 is effectively counteracted by plates 70 coming to rest against body 3.

[0032] The connection comprising screw 69 and nut screw 47 ensures mutual locking of bodies 45 and 51, is inaccessible from outside door 2, and provides for assembling handle 1 quickly and easily.

[0033] Body 51 is connected to frame 10 quickly by virtue of devices 55, and the resulting connection is both firm and safe.

[0034] Handle 1 is relatively lightweight and cheap to

produce, by frame 10 still being made of plastic material, and only bodies 45 and 51 being made of stronger, more expensive materials, and is therefore a good compromise between excessively weak known solutions - featuring plastic frames, with no additional bodies for supporting lock cylinder 40 - and relatively high-cost, heavy solutions in which the frame is made entirely of metal.

[0035] Clearly, changes may be made to handle 1 as described and illustrated herein without, however, departing from the scope of the present invention as defined by the appended claims.

[0036] In particular, bodies 45 and 51 may be formed made of materials other than those described, e.g. aluminium, steel, etc., and stronger with respect to the plastic material of frame 10.

Claims

1. A handle (1) for a vehicle door (2); the handle comprising,

- a frame (10) which is housable inside said door (2) and fixedly connectable to the door (2); said frame (10) comprising an end portion (13) presenting an annular flat surface (19) facing, when mounted to the door (2), an outer body (3) of said door (2), and lateral walls (21) extending perpendicularly to the annular flat surface (19);
- a lock cylinder (40) for receiving a key by which to release and engage a lock on said door (2), at least partly housed in said end portion (13); and
- connecting means (44) for connecting said lock cylinder (40) to said frame (10); said connecting means (44) comprising,

- a first supporting body (51) made of stronger material than said frame (10), fixedly connected to the frame (10), and supporting said lock cylinder (40);
- a second supporting body (45) housing said lock cylinder (40); and
- fastening means (69, 47) provided to connect said first and said second supporting body (51)(45) fixedly to each other;

characterized in that said first supporting body (51) comprises a front wall (52) and a lateral wall (54) and, when the first supporting body (51) is fitted to the end portion (13) and the handle (1) is mounted to the door (2), the front wall (52) is interposed between the annular flat surface (19) of the end portion (13) and the outer body(3) and the lateral wall (54) is fitted about the end portion (13) for laterally covering said end portion (13) letting said front wall (52) and lateral wall (54) of said first supporting body (51) resting on the annular flat surface (19) and the lateral

walls (21) of the end portion (13), and **in that** said first supporting body (51) is connected to the end portion (13) of said frame (10) by a retaining device (55) so as to provide a firm and safe connection.

2. A handle as claimed in Claim 1, **characterized in that** said lateral wall (54) comprises a projection (63) defining, together with said front wall (52), a seat (65); said seat (65) being engaged by a portion (25) of said frame (10) to retain said first supporting body (51) to the frame (10). 5
3. A handle as claimed in Claim 1 or 2, **characterized in that** said first supporting body (51) comprises at least one plate (70) projecting from the opposite side to said frame (10) so as to face said outer body (3) when the handle (1) is mounted to the door (2). 10
4. A handle as claimed in Claim 3, **characterized in that** said first supporting body (51) comprises two diverging said plates (70). 15
5. A handle as claimed in any one of the foregoing Claims, **characterized** the retaining device (55) comprising click-on retaining means interposed between said first supporting body (51) and said frame (10). 20
6. A handle as claimed in any one of the foregoing Claims, **characterized in that** said material of said first supporting body (51) is a metal alloy. 25
7. A handle as claimed in Claim 1, **characterized in that** said second supporting body (45) is fixedly connected to the lock cylinder (40) and made of stronger material than said frame (10). 30
8. A handle as claimed in Claim 1, **characterized in that** said fastening means (69, 47) comprise a screw-nut screw connection (69, 47). 35
9. A handle as claimed in Claims 2 and 8, **characterized in that** said screw-nut screw connection (69, 47) is associated with said projection (63). 40
10. A handle as claimed in any one of Claims 1 and 8 to 9, **characterized in that** said first supporting body (51) has a front opening (53) formed at a cavity (15) in said frame (10) housing said lock cylinder (40); said second supporting body (45) comprising a guard wall (48) partly closing said opening (53). 45
11. A handle as claimed in Claim 10, **characterized in that** said lock cylinder (40) extends along an axis (41); said guard wall (48) having a hole (49) permitting access to said lock cylinder (40) and defined by an annular portion (49a) resting axially on the lock cylinder (40). 50

Patentansprüche

1. Griff (1) für eine Fahrzeugtür (2), wobei der Griff folgendes aufweist:

- einen Rahmen (10), der in der Tür (2) aufgenommen und fest mit der Tür (2) verbunden sein kann, wobei der Rahmen (10) einen Endabschnitt (13) aufweist, der eine ringförmige, flache Oberfläche (19), die einem Außenkörper (3) der Tür (2) zugewandt ist, wenn sie an der Tür (2) angebracht ist, und Seitenwände (21) aufweist, die sich senkrecht zur ringförmigen, flachen Oberfläche (19) erstrecken;
- einen zumindest teilweise im Endabschnitt (13) aufgenommenen Schlosszylinder (40) zur Aufnahme eines Schlüssels, mit dem ein Schloss an der Tür (2) freigegeben und in Eingriff gebracht wird; und
- Verbindungsmittel (44) zur Verbindung des Schlosszylinders (40) mit dem Rahmen (10), wobei die Verbindungsmittel (44) folgendes aufweisen:

- einen ersten Tragkörper (51), der aus einem festeren Material besteht als der Rahmen (10), fest mit dem Rahmen (10) verbunden ist und den Schlosszylinder (40) trägt;
- einen zweiten Tragkörper (45), der den Schlosszylinder (40) aufnimmt; und
- Befestigungsmittel (69, 47), die dazu vorgesehen sind, den ersten Tragkörper (51) und den zweiten Tragkörper (45) fest miteinander zu verbinden;

dadurch gekennzeichnet, dass der erste Tragkörper (51) eine Stirnwand (52) und eine Seitenwand (54) aufweist, und wenn der erste Tragkörper (51) am Endabschnitt (13) angeordnet und der Griff (1) an der Tür (2) angebracht ist, die Stirnwand (52) zwischen der ringförmigen, flachen Oberfläche (19) des Endabschnitts (13) und dem Außenkörper (3) angeordnet und die Seitenwand (54) um den Endabschnitt (13) angebracht ist, um den Endabschnitt (13) seitlich zu bedecken, wodurch die Stirnwand (52) und die Seitenwand (54) des ersten Tragkörpers (51) an der ringförmigen, flachen Oberfläche (19) und an den Seitenwänden (21) des Endabschnitts (19) anliegen, und dass der erste Tragkörper (51) durch eine Haltevorrichtung (55) mit dem Endabschnitt (13) des Rahmens (10) so verbunden ist, dass eine feste und sichere Verbindung erhalten wird.

2. Griff nach Anspruch 1, **dadurch gekennzeichnet, dass** die Seitenwand (54) einen Vorsprung (63) aufweist, der gemeinsam mit der Stirnwand (52) einen Sitz (65) begrenzt, wobei ein Abschnitt (25) des Rah-

mens (10) in den Sitz (65) eingreift, um den ersten Tragkörper (51) am Rahmen (10) zu halten.

3. Griff nach Anspruch 1 oder 2, **dadurch gekennzeichnet, dass** der erste Tragkörper (51) mindestens eine Platte (70) aufweist, die von der dem Rahmen (10) entgegengesetzten Seite so hervorsteht, dass sie dem Außenkörper (3) zugewandt ist, wenn der Griff (1) an der Tür (2) angebracht ist.
4. Griff nach Anspruch 3, **dadurch gekennzeichnet, dass** der erste Tragkörper (51) zwei divergierende Platten (70) aufweist.
5. Griff nach einem der vorhergehenden Ansprüche, **dadurch gekennzeichnet, dass** die Haltevorrichtung (55) Einschnapp-Haltemittel aufweist, die zwischen dem ersten Tragkörper (51) und dem Rahmen (10) angeordnet sind.
6. Griff nach einem der vorhergehenden Ansprüche, **dadurch gekennzeichnet, dass** das Material des ersten Tragkörpers (51) eine Metallegierung ist.
7. Griff nach Anspruch 1, **dadurch gekennzeichnet, dass** der zweite Tragkörper (45) fest mit dem Schlosszylinder (40) verbunden ist und aus einem festeren Material besteht als der Rahmen (10).
8. Griff nach Anspruch 1, **dadurch gekennzeichnet, dass** die Befestigungsmittel (69, 47) eine Schraubenmutter-Schraube-Verbindung (69, 47) aufweisen.
9. Griff nach Anspruch 2 und 8, **dadurch gekennzeichnet, dass** die Schraubenmutter-Schraube-Verbindung (69, 47) dem Vorsprung (63) zugeordnet ist.
10. Griff nach einem der Ansprüche 1 und 8 bis 9, **dadurch gekennzeichnet, dass** der erste Tragkörper (51) eine vordere Öffnung (53) besitzt, die an einer Ausnehmung (15) im Rahmen (10) ausgebildet ist, welche den Schlosszylinder (40) aufnimmt, wobei der zweite Tragkörper (45) eine Schutzwand (48) aufweist, die die Öffnung (53) teilweise verschließt.
11. Griff nach Anspruch 10, **dadurch gekennzeichnet, dass** sich der Schlosszylinder (40) entlang einer Achse (41) erstreckt, wobei die Schutzwand (48) ein Loch (49) besitzt, das den Zugang zum Schlosszylinder (40) ermöglicht und durch einen ringförmigen Abschnitt (49a) begrenzt ist, der axial am Schlosszylinder (40) anliegt.

Revendications

1. Poignée (1) pour porte de véhicule (2) constituée

5 - d'un cadre (10) pouvant se loger à l'intérieur de ladite porte (2) et être relié fixement à la porte (2); ledit cadre (10) comprenant une partie d'extrémité (13) présentant une surface annulaire plane (19) faisant face, lorsqu'elle est montée sur la porte (2), à une partie externe (3) de ladite porte (2) et des parois latérales (21) placées perpendiculairement à la surface annulaire plane (19);

10 - d'un barillet (40) destiné à recevoir une clé permettant le verrouillage et le déverrouillage d'une serrure sur ladite porte (2), au moins partiellement logé dans ladite partie d'extrémité (13) ; et - de moyens de raccordement (44) dudit barillet (40) sur ledit cadre (10) ; lesdits moyens de raccordement (44) comprenant

15

20

- une première partie de support (51) fabriquée dans un matériau plus résistant que ledit cadre (10), fixement relié au cadre (10) et supportant ledit barillet (40);
- une deuxième partie de support (45) abritant ledit barillet (40); et
- des moyens de fixation (69, 47) servant à relier fixement lesdites première et seconde parties de support (51) (45) ;

caractérisée en ce que ladite première partie de support (51) est constituée d'une paroi avant (52) et d'une paroi latérale (54) et, lorsque la première partie de support (51) est fixée sur la partie d'extrémité (13) et la poignée (1) est montée sur la porte (2), la paroi avant (52) est interposée entre la surface annulaire plane (19) de la partie d'extrémité (13) et la partie externe (3), et la paroi latérale (54) est fixée autour la partie d'extrémité (13) pour recouvrir latéralement ladite partie d'extrémité (13), laissant ladite paroi avant (52) et ladite paroi latérale (54) de ladite première partie de support (51) reposer sur la surface annulaire plane (19) et les parois latérales (21) de la partie d'extrémité (13), et **en ce que** la première partie de support (51) est reliée à la partie d'extrémité (13) dudit cadre (10) par un dispositif de maintien (55) de manière à constituer un raccordement sûr et solide.

2. Poignée selon la revendication 1, **caractérisée en ce que** ladite paroi latérale (54) comprend une projection (63) délimitant avec ladite paroi avant (52) un siège (65) ; ledit siège (65) s'insérant dans une partie (25) dudit cadre (10) pour maintenir la première partie de support (51) sur le cadre (10).
- 55

3. Poignée selon la revendication 1 ou 2, **caractérisée**

- en ce que** ladite première partie de support (51) comprend au moins une plaque (70) partant du côté opposé dudit cadre (10) de manière à faire face à ladite partie externe (3) lorsque la poignée (1) est montée sur la porte (2). 5
4. Poignée selon la revendication 3, **caractérisée en ce que** ladite première partie de support (51) comprend deux plaques (70) divergentes. 10
5. Poignée selon l'une quelconque des revendications susmentionnées, **caractérisée en ce que** le dispositif de maintien (55) comprend des moyens de maintien encliquetable placés entre ladite première partie de support (51) et ledit cadre (10). 15
6. Poignée selon l'une quelconque des revendications susmentionnées, **caractérisée en ce que** ledit matériau dudit premier cadre de support (51) est un alliage métallique. 20
7. Poignée selon la revendication 1, **caractérisée en ce que** ladite seconde partie de support (45) est reliée fixement au barillet (40) et fabriquée dans un matériau plus résistant que ledit cadre (10). 25
8. Poignée selon la revendication 1, **caractérisée en ce que** lesdits moyens d'attache (69, 47) comprennent un raccordement à vis-écrou (69,47). 30
9. Poignée selon les revendications 2 et 8, **caractérisée en ce que** ledit raccordement vis-écrou (69,47) est associé à ladite projection (63). 35
10. Poignée selon l'une quelconque des revendications 1, 8 et 9, **caractérisée en ce que** ladite première partie de support (51) possède une ouverture avant (53) au niveau d'une cavité (15) dans ledit cadre (10) abritant ledit barillet (40); ladite deuxième partie de support (45) comprenant une paroi de protection (48) fermant partiellement ladite ouverture (53). 40
11. Poignée selon la revendication 10, **caractérisée en ce que** ledit barillet (40) s'étend le long d'un axe (41); ladite paroi de protection (48) possédant un orifice (49) permettant l'accès audit barillet (40) et délimité par une partie annulaire (49a) reposant dans le sens axial sur le barillet (40). 45

50

55

FIG.1

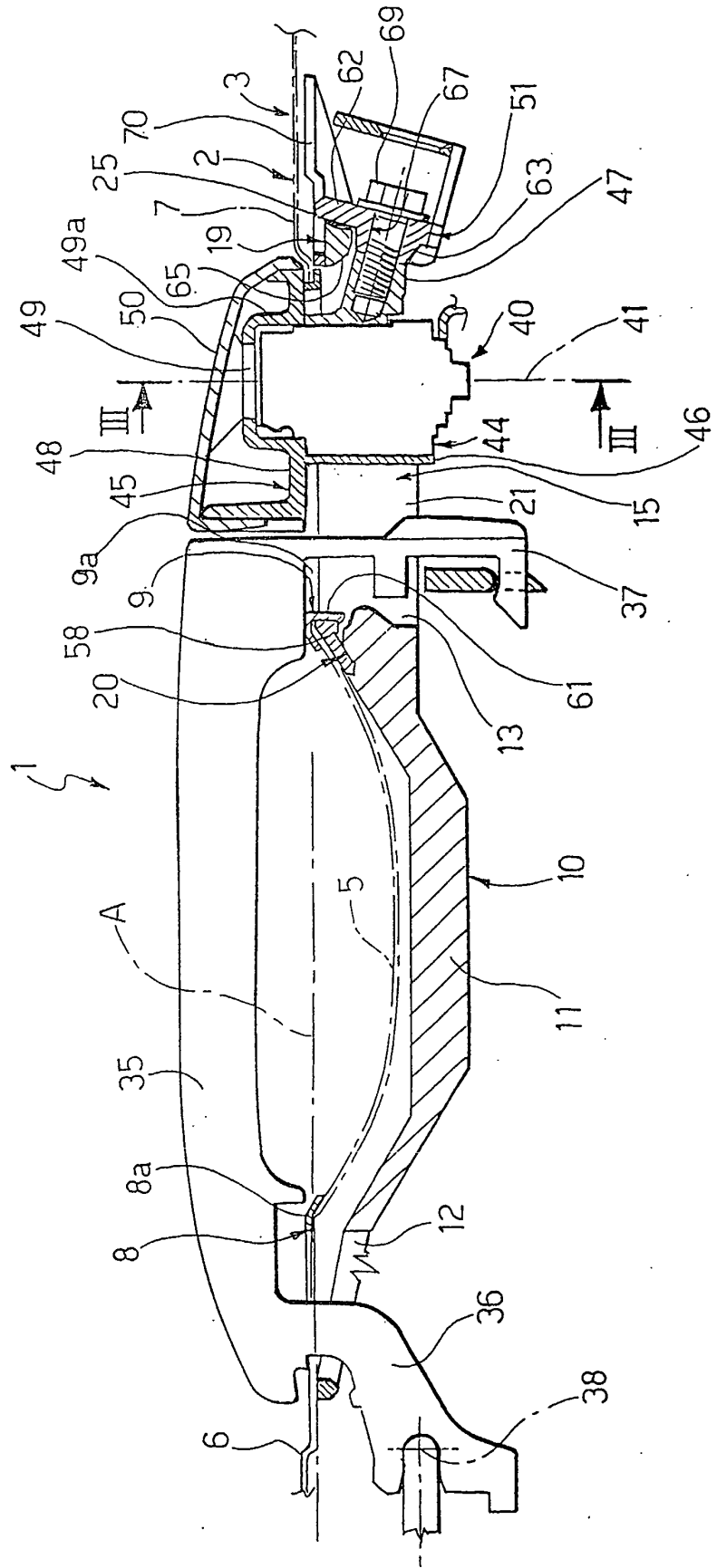

FIG. 4

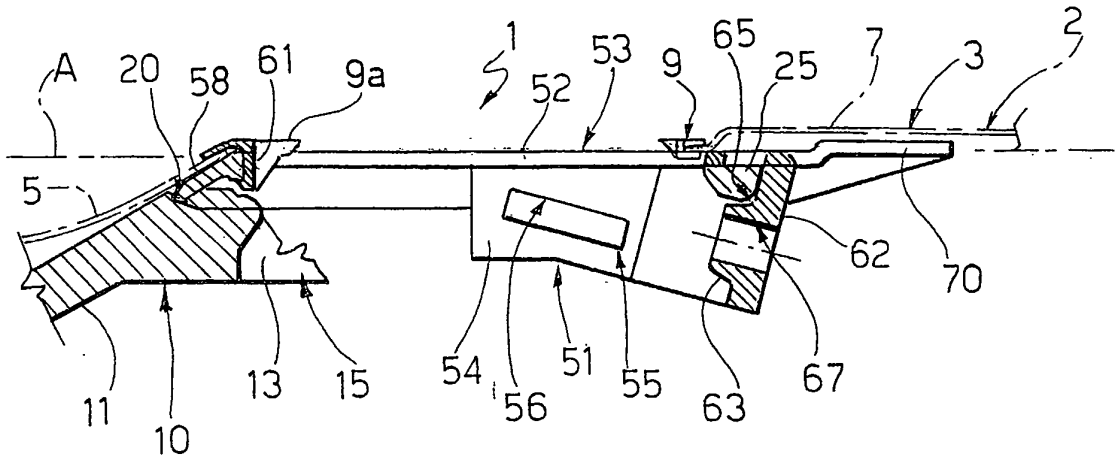

FIG. 2

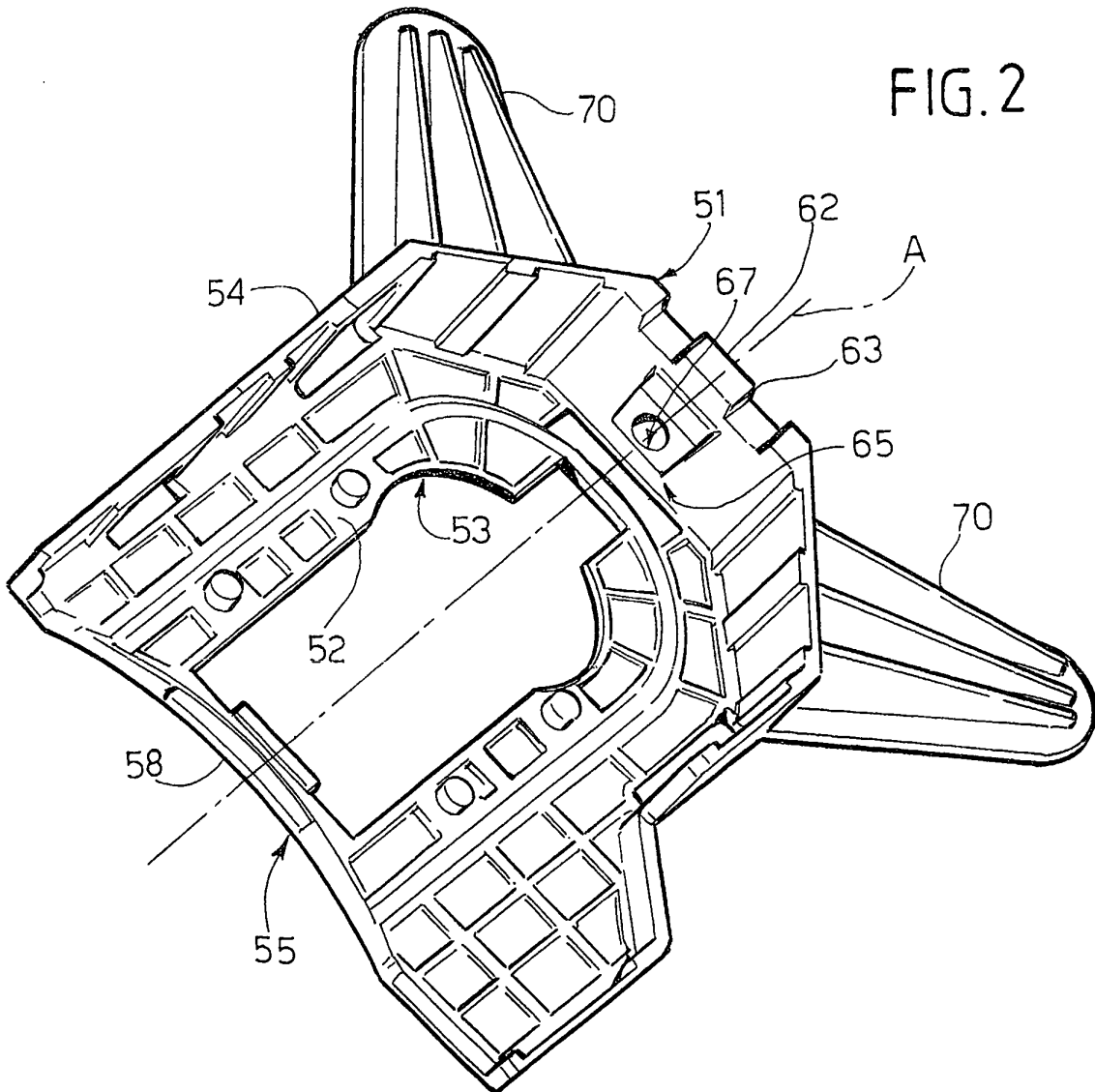

FIG. 3

