

(19)



Europäisches Patentamt  
European Patent Office  
Office européen des brevets



(11)

**EP 1 281 330 B1**

(12)

**EUROPEAN PATENT SPECIFICATION**

(45) Date of publication and mention  
of the grant of the patent:  
**15.02.2006 Bulletin 2006/07**

(51) Int Cl.:  
**A43D 37/00<sup>(2006.01)</sup> A43D 8/00<sup>(2006.01)</sup>**

(21) Application number: **01830522.7**

(22) Date of filing: **03.08.2001**

(54) **Device for manufacturing shoes**

Vorrichtung zur Schuhherstellung

Machine destinée à la fabrication des chaussures

(84) Designated Contracting States:  
**AT BE CH CY DE DK ES FI FR GB GR IE IT LI LU  
MC NL PT SE TR**  
Designated Extension States:  
**AL RO**

(43) Date of publication of application:  
**05.02.2003 Bulletin 2003/06**

(73) Proprietor: **ORMAC S.p.A.**  
**27029 Vigevano (Pavia) (IT)**

(72) Inventor: **Cucchetti, Celeste**  
**27029 Vigevano (Pavia) (IT)**

(74) Representative: **Ghioni, Carlo Raoul Maria**  
**Bugnion S.p.A.,**  
**Viale Lancetti 17**  
**20158 Milano (IT)**

(56) References cited:  
**EP-A- 0 596 570 EP-A- 0 990 399**  
**US-A- 4 996 012**

**EP 1 281 330 B1**

Note: Within nine months from the publication of the mention of the grant of the European patent, any person may give notice to the European Patent Office of opposition to the European patent granted. Notice of opposition shall be filed in a written reasoned statement. It shall not be deemed to have been filed until the opposition fee has been paid. (Art. 99(1) European Patent Convention).

## Description

**[0001]** The present invention relates to an apparatus for manufacturing shoes.

**[0002]** It is known that the apparatus for manufacturing shoes presently on the market generally consist of automated machines dedicated to a single working to be carried out on the shoe during the manufacturing process of same.

**[0003]** In particular these machines are usually made up of a support frame adapted to hold a work head provided with a tool designed for a particular working (rivetting, roughing, gluing or cementing, etc.).

**[0004]** Apparatus of known type are further equipped with a device for shoe support and locking designed to enable a correct positioning and fastening of the shoe to be manufactured.

**[0005]** Depending on the type of working for which the machine is intended, the same is provided with the appropriate degrees of freedom and the respective tool for carrying out the working itself.

**[0006]** In particular, if a roughing operation is wished to be carried out, the apparatus dedicated thereto will be provided with a toolhead on which a disc is mounted which has a suitable abrasive surface. The head will be also equipped with appropriate motors and motion-transmitting members capable of setting the roughing tool in quick rotation about its transverse axis and will also be provided with the appropriate members adapted to rotate the tool about an axis orthogonal to the rotation axis through varying angles, until a value of  $\pm 360^\circ$ .

**[0007]** For example, it is known from EP 0596570 a carding-cementing machine for shoes, which comprises a pair of supports respectively bearing one shoe to be worked and where two working heads are disposed above said supports.

**[0008]** In this known-type machine, the first head presents a carding tool, while the second head presents a cement-delivering tool; beside this, the supports and the working heads are mutually movable so that the carding tool can travel over a predetermined path on the bottom of a shoe (disposed on the first support), while the cementing tool can travel over a predetermined path on the bottom of a second shoe disposed on the second support. In addition, the mutual positions between the supports and the working heads can be interchanged with each other.

**[0009]** The apparatus will be then programmed in such a manner that the tool can follow the shoe outline to remove material therefrom where necessary and required.

**[0010]** Clearly, in the light of the above, each machine is accomplished so that it may be dedicated to performing a precise working on the shoe and for this reason the only operating flexibility of the machine consists in the possibility of carrying out the same working on different shoe typologies and conformations.

**[0011]** Therefore, in order to make an apparatus for shoe manufacture more flexible, a device capable of si-

multaneously carrying out more than one working on different shoes has been implemented and put on the market.

**[0012]** In particular, a roughing-cementing machine for shoes has been accomplished which is provided with two shoe-fastening supports each of which is arranged to lock a respective shoe to be processed. Two independent work heads are positioned above the supports and are provided with a cementing tool and a roughing tool respectively. Each support and the respective work head are also movable relative to each other in such a manner that the roughing tool can follow a predetermined path of travel on the lower surface of the shoe disposed on the first support and the cementing tool can cover the same way on the surface of the second shoe.

**[0013]** The two heads carrying the two tools are therefore independent of each other in their movements and their positions can also be exchanged in such a manner that the first tool can operate on the second shoe and the second tool can carry out the working for which it is intended on the first shoe.

**[0014]** While a device as briefly described above has greatly improved versatility in operation of the above mentioned machines, however it has some serious operating drawbacks as well.

**[0015]** First of all it should be noted that for the purpose of imparting all necessary relative movements between the cementing tool and the support (and consequently the shoe to be processed) and between the roughing tool and the respective shoe support, the presence of at least one motor, or in any case of corresponding actuating means, for each degree of freedom of each tool is required. This means that a roughing-cementing apparatus will be equipped with a number of motors and relative transmissions which is twice that of a single-working machine of common use. In other words, the above involves an important increase in the manufacturing costs and a great construction complexity.

**[0016]** As regards planning too, due to the necessity for the two work heads to be interchangeable, said heads must be built in such a manner that they do not interfere with each other, either during the working operations or during the movement steps of the heads themselves. As a result, the support heads cannot be made using components that are very stout from a structural point of view.

**[0017]** In the light of the above the overall reliability of the roughing-cementing device is greatly reduced also due to the fact that a large number of parts in motion and elements forming the apparatus is required.

**[0018]** In addition, due to the reduced masses and weights of each of the toolheads, any type of working that on the contrary should require the presence of structural stoutness, important masses and heavy weights (some rivetting operations, for example) cannot be executed.

**[0019]** On the other hand, if different workings are to be executed, appropriate working programs dedicated to each tool are to be studied. Therefore also the elec-

tronic components for the machine control will be affected by the greater construction complexity.

**[0020]** As a matter of fact, the solution offered by the roughing-cementing machine present on the market has high construction and servicing costs and does not possess a quite satisfactory working versatility, in spite of the improvements, as compared with the prior art.

**[0021]** Accordingly, the present invention aims at substantially obviating all drawbacks of the known art.

**[0022]** It is a first aim of the present invention to provide an apparatus for shoe manufacture enabling several typologies of different workings to be carried out without involving doubling of the parts in motion as compared with a machine provided with a single equipment so that a very high operating reliability will be maintained.

**[0023]** It is a further aim of the present invention to provide an apparatus for shoe manufacture capable of executing roughing and cementing workings and at the same time rivetting workings requiring heavy weights and important masses, by merely selecting and replacing the tools alone.

**[0024]** An auxiliary aim of the invention is then to make available an apparatus provided with many degrees of freedom so that the active surface of the tools can be conveniently adapted to and positioned on the shoe to be processed thereby obtaining more precise workings.

**[0025]** It is a further auxiliary aim of the invention to enable mounting of all motors adapted to generate movements of the tools and the work head, on a head block disengaged from the oscillatory movement of the work head itself.

**[0026]** The foregoing and further aims that will become more apparent in the course of the present description are substantially achieved by an apparatus for manufacturing shoes having the features recited in the accompanying claims.

**[0027]** Further features and advantages will be best understood from the detailed description of a preferred but not exclusive embodiment of an apparatus for manufacturing shoes in accordance with the present invention. This description will be taken hereinafter with reference to the accompanying drawings given by way of non-limiting example, in which:

- Fig. 1 is a perspective view from the left of an apparatus for manufacturing shoes in accordance with the present invention in which the support frame is absent;
- Fig. 2 is a perspective view from the right of the apparatus shown in Fig. 1;
- Fig. 3 is a front view of the apparatus in Fig. 1;
- Fig. 4 is a side view from the left of the apparatus shown in Fig. 1;
- Fig. 5 is a side view from the right of the apparatus seen in Fig. 1;
- Fig. 6 is a top view of the apparatus in Fig. 1;
- Fig. 7 shows a detail of the members for transmitting motion to the working tools;

- Fig. 8 is a longitudinal section of a propeller shaft shown in Fig. 7;
- Figs. 9-10 are enlarged and partly sectioned views of the propeller shaft shown in Fig. 7 under two operating conditions;
- Fig. 11 is a greatly diagrammatic side view of a device in accordance with the present invention with which a damper and a counter-spring for the weight of the work head are associated;
- Fig. 12 is a front view of an apparatus in accordance with the invention provided with a tool for roughing operations and a tool for cementing operations; and
- Fig. 13 diagrammatically shows a detail of two exhaust fans that can be associated with the respective working tools of the apparatus in accordance with the invention.

**[0028]** With reference to the drawings an apparatus for manufacturing shoes has been generally identified by reference numeral 1.

**[0029]** In particular the apparatus for manufacturing shoes 5 in accordance with the invention comprises a support frame 2 only partly shown in the figures in order to enable a better sight of the different parts forming the device itself.

**[0030]** The support frame 2 is designed to receive in engagement at least one shoe-supporting device denoted by 3. As can be viewed from the figures, the shoe-supporting device 3 has been shown only diagrammatically because it can be made in a great number of manners known by themselves and used in the presently available machines.

**[0031]** At all events the shoe supporting device will be provided with shoe-locking means 4 which is movable between at least one operating condition in which shoe 5 is kept in position so as to be able to carry out a particular working thereon and a second operating condition in which shoe 5 is released for the necessary loading-unloading operations of the apparatus.

**[0032]** Obviously, the locking means 4 too has been shown only diagrammatically as it is of a known and conventional type.

**[0033]** The shoe-supporting device 3 used in the present invention is provided with at least two degrees of freedom, i.e. it is movable relative to the support frame 2 in at least one direction Z and a second direction Y, which directions are transverse to each other.

**[0034]** As shown in the drawings and in particular in Fig. 1, the first movement direction Z of the support device 3 is coincident with a substantially vertical axis whereas the second movement direction Y lies in a substantially horizontal plane.

**[0035]** Apparatus 1 also has at least one first and one second working tools 7, 8 arranged to operate on a shoe 5 to be processed and which are both mounted on a head block 6.

**[0036]** The head block 6 too is in engagement with the support frame 2 and, in detail, is movable in its entirety

at least along a movement direction X lying in a substantially horizontal plane. The movement directions X of the head block 6 and Y of the support device 3 are transverse to each other and in particular mutually perpendicular; in this way shoe 5 to be worked and tools 7, 8 mounted on the apparatus will be moved relative to and with each other in three Cartesian axes X, Y and Z.

**[0037]** Since they are linked to the whole head block 6, both the first 7 and second 8 tools will follow the head block 6 itself during its translation along axis X.

**[0038]** Obviously, the possibility of executing the relative movements between the tools and shoes to be processed will be essential and therefore it is optionally possible that movement along axis Z (which in the embodiment shown is practically a vertical axis) should be carried out by the head block 6, while the support device 3 will be provided with the only movement along axis Y.

**[0039]** As can be readily understood, further different combinations in the head - support movements can be accomplished, all of them falling within the inventive idea of the present invention.

**[0040]** From a structural point of view the head block 6 is made up of a bearing body 9 directly in engagement with the support frame and in particular designed to traverse along a predetermined number of slide guides 10. The bearing body 9 in turn carries a work head 11 mounted on said body in an oscillatable manner. More particularly, the work head 11 is pivotally mounted to one end of the bearing body 9 at an oscillation axis W.

**[0041]** Since the working tools 7, 8 are directly mounted on the work head 11, said tools will, integrally with each other, follow not only translation of the whole head block 6 but also the oscillations of the work head 11 about axis W.

**[0042]** As can be still viewed from the accompanying drawings, at least one of the tools 7, 8 (but preferably both of them in the configuration shown in Figs. 1-6) has a substantially disc-shaped conformation.

**[0043]** In the particular type of apparatus shown such tools are in fact designed to be set in quick rotation around a respective longitudinal axis 7a, 8a in the direction identified by the arrows in Fig. 1.

**[0044]** Then, in order to obtain an improved working, and as better clarified in the following, the working tools 7, 8 can be driven in rotation about a respective axis 7b, 8b parallel to the machining axis (see Fig. 1). The longitudinal rotation axis 7a, 8a of the disc-shaped tools is transverse, preferably orthogonal, to the machining axis.

**[0045]** Therefore, in the light of all the above described movements, each of the two tools carried by the work head is capable of traversing along axis X, oscillating about axis W, rotating about a longitudinal rotation axis 7a, 8a of its own, as well as of rotating through  $\pm 360^\circ$  about an axis 7b, 8b parallel to the machining axis. Simultaneously the shoe-supporting device 3 is capable of moving shoe 5 relative to tools 7, 8 along two transverse axes Z and Y.

**[0046]** Obviously the invention is also suitably ar-

ranged for interchangeability of the tools either to replace the tools possibly worn out, or to modify the machine operation (type of working).

**[0047]** As can be viewed from Fig. 3, the machine can be set for execution of roughing-rivetting operations.

**[0048]** The same apparatus, after replacement of the tools and tool-carriers, can be converted to a roughing-cementing machine (see Fig. 12).

**[0049]** The possibility of a mere tool and tool-carrier replacement while keeping the whole machine architecture unchanged enables achievement of a very versatile apparatus for shoe manufacture capable of being used, depending on requirements, for executing different types of workings such as roughing-rivetting, roughing-cementing, roughing-roughing, rivetting-cementing, rivetting-rivetting and still other workings. In addition, by arranging an appropriate tool to carry out rough-shaping, the apparatus of the present invention will be adapted, after mounting the appropriate tools thereon, to operate as a rough-shaping-rivetting, rough-shaping-cementing, rough-shaping-roughing machine or at all events to operate according to any combination of workings (which obviously will depend on the type of tools 7 and 8 mounted to the apparatus itself).

**[0050]** On the other hand the apparatus is able to obtain the above described degree of versatility while maintaining the relative basic movements between the tool and shoe without replacement of other parts of the machine being required and with a minimum number of mechanical components.

**[0051]** In the case shown in Fig. 12, the cement-applying or cementing tool 8 will carry a motor mounted thereon and dedicated to rotation of a brush and will be also able to oscillate about an axis parallel to axis 8a.

**[0052]** One of the features of the present invention is then that of giving the working tools 7, 8 all the above described movements although no motor is mounted on the work head 11 (except for the rotation motor for the cement-applying tool); this for the purpose of avoiding the motors themselves being submitted to the oscillations of the work head 11, as well as avoiding too heavy a weight being present on the head itself.

**[0053]** In order to enable such arrangement, actuating means 12 is associated with frame 2 and is activated to enable a relative displacement between the shoe-supporting device 3 and the working tools 7, 8. The actuating means 12 comprises transmission systems designed to allow an efficient motion transmission while enabling the work head to oscillate.

**[0054]** In particular, the actuating means 12 designed to give a rotatory motion to axes 7a, 8a of the tools mounted on the work head 11 consists of a motor 13, first motion-transmitting members 14 which are able to transfer motion from motor 13 to at least one pulley 15 mounted on the work head 11, and second motion-transmitting members 16 which are able to transfer motion from pulley 15 to the first and second working tools 7, 8 (see in particular Figs. 6 and 7).

**[0055]** In more detail, and referring particularly to Figs. 1, 4, 6 and 7, it is possible to notice that motion of motor 13 is transmitted, possibly through appropriate reduction gears, from a first flexible element 17, in this particular embodiment consisting of a cogged belt, to a first pulley 18 mounted coaxially with the oscillation axis W. A second pulley 19 integral in its rotatory movement with said first pulley 18 receives movement from motor 13 and through a second flexible element 20, i.e. a second cogged belt, transmits the same movement to a third pulley 21 directly mounted on the work head. Under this situation, through a bevel gear pair for example, which is provided with a first gear associated with the third pulley 21 and a second gear associated with a pulley 15 mounted on the work head 11, the rotatory motion taking place about an axis parallel to the oscillation axis W is transferred to an axis transverse to said oscillation axis and parallel to the machining axis. The second motion-transmitting members 16 designed to transmit movement from pulley 15 mounted on the work head 11, directly to the working tools 7, 8, are on the contrary of a slightly more complicated structure because they must take into consideration possible displacements along the axes X and Z of the working tools 7, 8.

**[0056]** In fact as can be viewed from Fig. 7, the work head 11 is also provided with positioning means 22 active on each of the working tools 7, 8 to bring an active portion 23 thereof close to a working plane preferably containing the oscillation axis W of the work head 11.

**[0057]** This means that from a structural point of view the working tools 7, 8 are mounted on the work head by use of a first and a second connecting rods 24, 25 for each tool, which connecting rod has respective portions hinged on the work head 11 on one side, and on a tool-carrying support 26, 27 on the other side. This positioning means 22 further comprises an actuating device (not shown) active on the connecting rods 24, 25 to cause raising/lowering displacements of the active portion 23 of tools 7, 8, as indicated by an arrow still in Fig. 7.

**[0058]** The necessity to be able to carry out these slight tool displacements is linked to the fact that said tools are subjected to wear during working and therefore they must be positioned again for obtaining a precise working at any time.

**[0059]** On the other hand, the possibility of moving the tools enables a constant work pressure to be maintained during all operations on the shoes.

**[0060]** Finally this adjustment possibility enables the work head 11 to be adapted to working discs of different diameters and sizes.

**[0061]** However it should be noted that due to the presence of these movements causing lowering of the tool along axis Z and translation of same parallel to axes X and W (as shown by arrows A and B in Fig. 7), a series of expedients are to be adopted for transmitting motion from pulley 15 directly mounted on the work head 11 to the tools 7, 8 themselves.

**[0062]** For the above reasons the second mo-

tion-transmitting members 16 comprise, for each tool, a rotating head 29 set in rotation via a belt 30 by pulley 15 mounted on head 11 and a first shaft 31 suitable to receive a rotatory motion from the rotating head 29 and provided with an inner cavity 32 (see Figs. 7 to 10, in particular).

**[0063]** A second shaft 33 slidably engaged in cavity 32 in the first shaft 31 is provided with shaped expansions 34 (in particular a three-lobe shaft is used) capable of transmitting a twisting moment and enabling an axial sliding of the telescopic type between the two shafts.

**[0064]** This possibility of sliding between the two shafts 31, 33 enables displacements of the working tools 7, 8 in a downward direction towards arrow B (and possibly in an upward direction) to be compensated for, while however enabling transmission of the driving torque.

**[0065]** In addition, for the purpose of compensating for translation in a horizontal direction (arrow A) of the working tools 7, 8, at least one and preferably two flexible connecting elements 35 are provided; said flexible connecting element is adapted to enable relative displacements in a vertical plane between a rotation axis 36 of head 29 and a rotation axis 37 of the shaft transmitting motion to the tool.

**[0066]** In particular, such elements will consist from a structural point of view, of a disc made up of a first layer of rigid material 35a, a second layer of flexible material 35b directly in engagement with the first layer and a third layer 35c of rigid material in engagement with the flexible material. By making head 29 rigid with the first disc 35a and mounting a first shaft 31 directly on the third disc 35c, said pieces will be able to enjoy a little freedom as regards their sliding in a horizontal plane.

**[0067]** By interposing an additional one of the above devices between the second shaft 33 and the shaft moving the tool, a further possibility of horizontal movement is supplied (see Figs. 9 and 10 for details).

**[0068]** Therefore, due to this expedient this second typology of displacements can be also compensated for and an efficient operation of the positioning device for tools 7, 8 is enabled.

**[0069]** In addition, due to the particular motion-transmission typology, rotation of tools 7, 8 about their rotation axis 7a, 8a takes place simultaneously and integrally with each other (in a synchronous manner) since such a rotation is generated by a single motor.

**[0070]** Then, for enabling rotations through 360° about axes 7b, 8b, the actuating means 12 is equipped with a motor 38 operatively associated with the support frame 2 and a flexible motion-transmitting element 39 for each tool which is adapted to receive the rotatory motion from motor 38 and to enable transferring of same to tools 7, 8 that are oscillatably mounted on the head block 11 (see Fig. 11). In particular the rotatory motion from the reduction gears of a motor is caused to pass through a bevel gear pair interposed between motor 38 and the flexible element 39 (a first gear of the bevel gear pair receives the rotatory motion from the motor and transfers it to a

second gear integral with the flexible element). The flexible element 39 then transfers motion to a rotating head 40 directly mounted on the oscillating work head 11, as shown in Fig. 8.

**[0071]** Use of a flexible element 39 (a steel cable or other appropriate element) allows transmission of a rotary motion from motor 38 which is mounted on the head block 6 and therefore does not oscillate, to a work head 11 capable of carrying out angular displacements of important amounts.

**[0072]** According to an alternative embodiment of the present invention it is in any case possible for the actuating means 12 to comprise a motor, preferably an electric one, mounted at either tool 7 or 8; such an electric motor will transmit motion to a tool due to a first transmission gear, whereas through a Cardan shaft (or, more generally, an equivalent transmission apparatus) extending between the two tools 7 and 8 it will transmit motion to the second tool too. In any case, by virtue of this solution an apparatus of reduced weight can be obtained without impairing the operating possibilities of tools 7 and 8. It should be further appreciated that in this case, instead of arranging a motor connected to the fixed part (i.e. the support frame 2) of the apparatus, a motor is set that moves integrally with one of the movable parts of the apparatus itself.

**[0073]** In the case of a cementing tool (Fig. 12) the flexible cable 39 transmits motion to a reduction motor of the worm screw type 48 which in turn transmits it to a disc 49 movable in rotation and suitable to cause oscillation, through a connecting rod 50, of a pivotally-mounted bar 51 rigidly connected to the cementing tool 8 so as to give the latter an oscillatory motion about axis 8c parallel to axis 8b (arrow 52).

**[0074]** Position of axis 8c can be conveniently selected based on the operating requirements; in particular, it is possible to cause positioning of axis 8c at the head portion of the cementing tool (in this case it will be a substantially horizontal ideal oscillation axis). Due to this particular choice, which is implemented through an appropriate kinematic mechanism for movement of the cementing tool, an excellent contact of the head portion of the tool itself (which practically carries out spreading of the glue or cement on the shoe being worked) as bending of the different shoe regions varies, is ensured and at the same time arrangement of complicated mechanisms is not required.

**[0075]** Alternatively, the head portion of the cementing tool can move with a pendular movement about axis 8c (in this connection see the accompanying figures).

**[0076]** The apparatus for shoe manufacture in accordance with the present invention is further provided with additional advantageous features for correct operation of same.

**[0077]** Firstly, it further comprises damper means 41 interposed between the work head 11 and bearing body 9 to avoid generation of undesirable vibrations during the oscillation movements of the work head 11. In fact, in the

absence of the damper means 41 vibrations in the work head 11 were generated in particular at the positions of maximum inclination of the latter, which vibrations were transmitted to the working tools 7, 8 thereby giving rise to imprecise and inexact workings.

**[0078]** In particular the damper means 41 is made up of a cylinder 42 associated with the work head 11 and provided with a cavity filled with a viscous fluid, such as oil for example, and inside which a slider 43 is movable which is rigidly linked to a rod 44 directly in engagement with the bearing body 9. Slider 43 together with the inner wall of cylinder 42 defines two regions in the cavity that are in fluid communication with each other through a blow-by space 45.

**[0079]** During the oscillatory movement of the work head 11, slider 43 moves within cylinder 42 and gives rise to oil blow-by through the foramina created between the inner wall of cylinder 42 and slider 43. The reaction forces generated as a result of the oil passing through the blow-by space are of such a nature that they prevent arising of undesirable vibrations during the oscillations of the work head 11.

**[0080]** The apparatus also comprises elastic means 46 disposed between the bearing body 9 and work head 11 and designed to become operating when the work head 11 is at a position of maximum oscillation (see Fig. 11). The elastic means 46 is defined by a spring for example, which is proportionally compressed as the inclination angle of the work head 11 increases.

**[0081]** According to an alternative embodiment of the present invention, the elastic means 46 may comprise at least one pneumatic actuator (of the simple-action and/or double-action type); conveniently, pressure-adjusting means can be interlocked with this actuator, for establishing the appropriate operating parameters. For instance, the presence of a particular pressure reducer can be provided which acts on one of the two pneumatic chambers of the actuator so that pressure within said one chamber is maintained constant. More generally, by conveniently operating on the pressure-adjusting means it is possible to select the force exerted by the pneumatic actuator depending on the displacement of the work head 11.

**[0082]** Therefore, by virtue of the presence of a spring, the force variations necessary for movement of the work head and generated due to variation in the weight distribution can be compensated for.

**[0083]** In addition, the head block 6 can be provided with a casing 53 designed to surround the working tools at least partly so as to avoid spreading of the removed material as a result of machining, during the roughing operations for example. Such a casing 53 will be preferably made of a transparent material so that the working operations on the shoe can be examined at any time.

**[0084]** A first and a second ducts 54 disposed laterally of the respective working tool 7, 8 can be then connected with casing 53. Sucking means can create a vacuum in said ducts so as to take in the waste material abraded

from the shoe surface or the vapours burst out from glues or cements. Advantageously, a selecting device placed at the junction point between the two sucking ducts enables a respective sucking channel to be activated while suction is shut off on the other so that material or vapour removal from the work area may take place in the most efficient manner without the sucking means being doubled (see Fig. 13 in particular). In this case, within the scope of the present invention (and in order to ensure the greatest operating flexibility to the apparatus), it is possible for the selecting device to simultaneously act on both sucking ducts, shutting down the suction flow thereof. More generally, depending on the particular requirements, the sucking ducts can be either both opened or both closed or only one of them can be opened; these four possible operating conditions can be selected in any manner through the selecting device.

**[0085]** It should be further recognized that the apparatus in accordance with the invention can be provided with more than one shoe-supporting device 3 to enable the loading-unloading operations to be carried out simultaneously with the working operations on another shoe, thus further increasing the production speed.

**[0086]** The invention achieves important advantages.

**[0087]** First of all due to the presence of a single head on which both tools are mounted, an apparatus for shoe manufacture is obtained which is able to carry out different working typologies.

**[0088]** The apparatus of the invention is adapted to allow the head block - shoe-supporting device to have at least six degrees of freedom along respective axes for each working tool using a minimum number of motors and movable parts, thus increasing the device reliability.

**[0089]** Then, due the presence of an oscillation axis W adapted to enable the working tools to be inclined by a respective angle, the working operations on the shoes are improved and more precise. In fact, due to the movements that can be given to the working tools, the latter can follow the tridimensional shape of the shoe by tilting while always keeping parallel to the surface to be machined. On the other hand, rotation through  $\pm 360^\circ$  about the machining axis enables said tools to act on the shoe on the local perpendicular, at any point of its shape.

**[0090]** The mere replacement of the tools and tool carriers allows the apparatus in accordance with the invention to be employed in different working combinations, rivetting-roughing, roughing-cementing, roughing-roughing, rivetting-cementing and other operations for example, thus giving the apparatus a great operating versatility thereby giving rise to a complete system for shoe manufacture.

**[0091]** In addition, the presence of a single work head having an important mass enables great efforts to be withstood on the head itself so that also heavy operations such as rivetting for example can be carried out.

**[0092]** Furthermore, the presence of particular expedients in transmitting the different movements required allows mounting of the motors externally of the oscillating

work head so that said motors will not be submitted to too many stresses and therefore will not be damaged.

**[0093]** The invention is also advantageous in its most specific aspects.

5 **[0094]** The presence of a vibration damper and an elastic element adapted to assist in the oscillating motion allows a greater accuracy in machining and in addition the motors are submitted to less efforts during the machine movements.

10 **[0095]** Due to the particular conformation of the sucking hood a single fan can offer an excellent sucking action selectively on one or the other of the two sucking ducts thereby ensuring an efficient cleaning of the regions submitted to machining.

15 **[0096]** In addition, in the case of the roughing-cementing (or rivetting-cementing) combination, or at all events when a support for the cementing head is present, use of a sucking cup for each individual support joined to the selecting device enables the removed material and/or 20 sucked vapours to be fully collected and directed to different environments (for example the waste from roughing to a collecting bag and the vapours from the cement solvents to an appropriate filter).

## 25 Claims

1. An apparatus for manufacturing shoes comprising:
  - 30 - a support frame (2);
  - at least one shoe-supporting device (3) operatively associated with the support frame (2);
  - a head block (6) in engagement with said support frame (2);
  - 35 - at least one first and one second working tools (7, 8) arranged to operate on a shoe (5); and
  - actuating means (12) associated with the frame (2) and activated to enable a relative displacement between the shoe-supporting device (3) and the working tools (7, 8), **characterized in** 40 **that** said first and second working tools (7, 8) are both mounted on the head block (6).
2. An apparatus as claimed in claim 1, **characterized in that** the shoe-supporting device comprises 45 means (4) for locking said shoe (5), which means is movable between at least one operating condition in which it holds the shoe (5) in position for working and a second operating condition in which it releases the shoe (5) for a loading-unloading operation.
3. An apparatus as claimed in anyone of the preceding claims, **characterized in that** the shoe-supporting device (3) is movable relative to the support frame 50 (2) in at least one first (Z) and one second (Y) directions transverse to each other.
4. An apparatus as claimed in claim 3, **characterized**

- in that** the first movement direction (Z) of the shoe-supporting device (3) is coincident with a substantially vertical axis and said second movement direction (Y) lies in a substantially horizontal plane.
- 5
5. An apparatus as claimed in anyone of the preceding claims, **characterized in that** the head block (6) is movable in at least one movement direction (X) lying in a substantially horizontal plane.
- 10
6. An apparatus as claimed in anyone of the preceding claims, **characterized in that** the head block (6) is movable in a movement direction (Z), said movement direction (Z) preferably being transverse, and more preferably perpendicular, to axes (X) and/or (Y).
- 15
7. An apparatus as claimed in anyone of claims 3 and 5, **characterized in that** the movement direction (X) of the head block (6) and the second movement direction (Y) of the shoe-supporting device (3) are transverse, and preferably orthogonal, to each other.
- 20
8. An apparatus as claimed in anyone of the preceding claims, **characterized in that** the head block (6) comprises a bearing body (9) in engagement with the support frame and a work head (11) oscillatably mounted on the bearing body (9), said first and second tools (7, 8) being in engagement with said work head (11).
- 25
9. An apparatus as claimed in anyone of the preceding claims, **characterized in that** at least one of said working tools (7, 8), and preferably both of them, has a substantially disc-shaped conformation, said actuating means (12) being active on the disc-shaped working tools (7, 8) to set them in rotation about a respective longitudinal axis (7a, 8a).
- 30
10. An apparatus as claimed in anyone of the preceding claims, **characterized in that** the actuating means is active on the working tools (7, 8) to set them in rotation about an axis (7b, 8b) parallel to the machining axis.
- 35
11. An apparatus as claimed in claims 9 and 10, **characterized in that** said longitudinal rotation axis (7a, 8a) of the disc-shaped tools (7, 8) is transverse, and preferably orthogonal, to the machining axis.
- 40
12. An apparatus as claimed in claim 8, **characterized in that** it further comprises damper means (41) operatively interposed between the work head (11) and bearing body (9) to avoid vibrations being generated during the oscillation movements of the work head (11).
- 45
13. An apparatus as claimed in claim 12, **characterized**
- in that** the damper means (41) comprises:
- a cylinder (42) associated with the work head (11) and provided with a cavity filled with a viscous fluid; and
  - a slider (43) movable within the cavity and rigidly linked to a rod (44) connected to the bearing body (9), said slider (43) together with the inner wall of said cylinder (42) defining two regions in said cavity which are in fluid communication with each other through a blow-by space (45).
14. An apparatus as claimed in claim 8, **characterized in that** it comprises elastic means (46) operatively interposed between the bearing body (9) and the work head (11) and operatively active on said head at a position of maximum inclination of the work head (11) itself.
15. An apparatus as claimed in claim 14, **characterized in that** said elastic means (46) comprises at least one spring.
16. An apparatus as claimed in claim 14, **characterized in that** the elastic means (46) comprises at least one pneumatic actuator, said pneumatic actuator being of the simple-action and/or double-action type.
17. An apparatus as claimed in claim 16, **characterized in that** it further comprises pressure-adjusting means operatively interlocked with the pneumatic actuator to establish the operating parameters thereof.
18. An apparatus as claimed in anyone of the preceding claims, **characterized in that** the head block (6) comprises:
- a casing designed to surround the working tools (7, 8) at least partly;
  - at least one first and one second sucking ducts connected to the casing and associated with a respective working tool (7, 8); and
  - sucking means active on said ducts to create a vacuum in the ducts themselves.
19. An apparatus as claimed in claim 18, **characterized in that** it further comprises a selecting device capable of starting the sucking means so as to act on one and/or both of the sucking ducts, said selecting device selectively shutting off suction in one or both of said sucking ducts.
20. An apparatus as claimed in claim 8, **characterized in that** the work head (11) comprises positioning means (22) active on each of the working tools (7, 8) to bring an active portion (23) of the latter close to a working plane, said working plane preferably



containing an oscillation axis (W) of the work head (11).

21. An apparatus as claimed in claim 20, **characterized in that** the positioning means (22) comprises for each tool, at least one first and one second connecting rods (24, 25) having respective portions hinged on the work head (11 on one side, and on a tool-carrier stand (26, 27) on the other side, and an actuating device active on said connecting rods (24, 25) to cause raising/lowering displacements of the active portion (23) of the tools (7, 8).
22. An apparatus as claimed in any one of the preceding claims, **characterized in that** the actuating means comprises:
- a motor (13);
  - first members (14) for transmitting motion from the motor (13) to at least one pulley (15) mounted on the work head (11); and
  - second members (16) for transmitting motion from the pulley (15) to said first and second working tools (7, 8).
23. An apparatus as claimed in claim 22, **characterized in that** the first motion-transmitting members (14) comprise:
- a first pulley (18);
  - a first flexible element (17), preferably a cogged belt, capable of transmitting motion from the motor (13) to the first pulley (18);
  - a second pulley (19) integral with said first pulley (18);
  - a third pulley (21);
  - a second flexible element (20), preferably a cogged belt, capable of transmitting motion from the second pulley (19) to the third pulley (21);
  - at least one bevel gear pair comprising a first gear operatively associated with the third pulley (21) and a second gear operatively associated with the pulley (15) mounted on the work head (11).
24. An apparatus as claimed in claim 22, **characterized in that** the second motion-transmitting members (16) comprise for each tool:
- a rotating head (29) set in rotation by the pulley (15) mounted on the work head (11);
  - a first shaft (31) receiving a rotatory motion from the rotating head (29) and provided with an inner cavity;
  - a second shaft (33) slidably engaged in said cavity of the first shaft (31), said first shaft (31) having shaped portions (34) for transmission of a twisting moment to the second shaft (33); and
- a flexible connecting element (35) present on said first shaft (31) and capable of allowing relative displacements in a vertical plane between a rotation axis (36) of the rotating head (29) and a rotation axis (27) of the second shaft (33).
25. An apparatus as claimed in claim 8, **characterized in that** during the working steps of the apparatus the tools (7, 8) are both movable integrally with the work head (11).
26. An apparatus as claimed in claim 10, **characterized in that** the tools (7, 8) rotate about the axes (7b, 8b) parallel to the machining axis in a simultaneous and integral manner.
27. An apparatus as claimed in claim 10, **characterized in that** the actuating means comprises:
- a motor (38) operatively associated with the support frame (12);
  - a flexible motion-transmitting element (39) receiving a rotatory motion from said motor (38) and adapted to enable transferring of said motion to the tools (7, 8) mounted on the work head (11).
28. An apparatus as claimed in claim 27, **characterized in that** the actuating means (12) further comprises:
- a bevel gear pair interposed between the motor (38) and the flexible element (39), a first gear of said bevel gear pair receiving a rotatory motion from the motor and transferring it to a second gear integral with the flexible element; and
  - a rotating head (40) direct mounted on the oscillating work head (11) and receiving motion from the flexible element (39).
29. An apparatus as claimed in any one of the preceding claims, **characterized in that** it comprises two or more shoe-supporting devices (3) operatively associated with the support frame (2).
30. An apparatus as claimed in any one of the preceding claims, **characterized in that** said first and second tools are set from roughing, rivetting, rough-shaping and gluing or cementing tools.
31. An apparatus as claimed in claim 30, **characterized in that** said first and second tools are replaceable and interchangeable with each other to enable at least assembling of a rivetting-roughing, roughing-cementing, roughing-roughing, rivetting-cementing, rivetting-rough-shaping, rough-shaping-cementing, rough-shaping-rough-shaping apparatus.

32. An apparatus as claimed in claim 1, **characterized in that** one of said tools is a cementing tool; said tool being oscillatably movable upon the action of the actuating means around at least one axis (8c).
33. An apparatus for manufacturing shoes as claimed in claim 1, **characterized in that** it comprises a support frame (2), at least one shoe-supporting device (3) operatively associated with the support frame (2), a head block (6) in engagement with said support frame (2), at least one working tool (7) arranged to operate on a shoe (5), and actuating means (12) associated with the frame (2) and operated to enable a relative displacement between the shoe-supporting device (3) and the working tool (7), said working tool (7) being movable relative to the shoe (5) in at least three axes (X, Y, Z) substantially orthogonal to each other and being oscillatable about a substantially horizontal axis.

### Patentansprüche

1. Vorrichtung zur Schuhherstellung umfassend:
- einen Stützrahmen (2);
  - mindestens eine Schuhtragvorrichtung (3), die dem Stützrahmen (2) wirksam zugeordnet ist;
  - einen Kopfblock (6), der am Stützrahmen (2) eingreift;
  - mindestens ein erstes und ein zweites Bearbeitungswerkzeug (7, 8), die bereitgestellt sind, einen Schuh (5) zu bearbeiten; und
  - Verstellmittel (12), die dem Stützrahmen (2) zugeordnet sind und eine relative Verschiebung zwischen der Schuhtragvorrichtung (3) und den Bearbeitungswerkzeugen (7, 8) betragen, **dadurch gekennzeichnet, dass** das erste und das zweite Bearbeitungswerkzeug (7, 8) beide am Kopfblock (6) angebracht sind.
2. Vorrichtung nach Anspruch 1, **dadurch gekennzeichnet, dass** die Schuhtragvorrichtung Mittel (4) zur Verriegelung des Schuhs (5) umfasst, die zwischen mindestens einer Arbeitsstellung, in der sie den Schuh (5) für die Bearbeitung halten, und einer zweiten Arbeitsstellung beweglich sind, in welcher sie den Schuh (5) für eine Lade-/Entladearbeit loslassen.
3. Vorrichtung nach einem beliebigen der voranstehenden Ansprüche, **dadurch gekennzeichnet, dass** die Schuhtragvorrichtung (3) gegenüber dem Stützrahmen (2) gemäß mindestens einer ersten (Z) und einer zweiten (Y) zueinander queren Richtung beweglich ist.
4. Vorrichtung nach Anspruch 3, **dadurch gekennzeichnet, dass** die erste Verstellrichtung (Z) der Schuhtragvorrichtung (3) mit einer im wesentlichen vertikalen Achse zusammenfällt und die zweite Verstellrichtung (Y) in einer im wesentlichen horizontalen Ebene liegt.
5. Vorrichtung nach einem beliebigen der voranstehenden Ansprüche, **dadurch gekennzeichnet, dass** der Kopfblock (6) mindestens längs einer Verstellrichtung (X) beweglich ist, die in einer im wesentlichen horizontalen Ebene liegt.
6. Vorrichtung nach einem beliebigen der voranstehenden Ansprüche, **dadurch gekennzeichnet, dass** der Kopfblock (6) gemäß einer Verstellrichtung (Z) beweglich ist, wobei die Verstellrichtung (Z) bevorzugter Weise zu den Achsen (X) und/oder (Y) bevorzugter Weise senkrecht liegt.
7. Vorrichtung nach einem beliebigen der voranstehenden Ansprüche 3 und 5, **dadurch gekennzeichnet, dass** die Verstellrichtung (X) des Kopfblockes (6) und die zweite Verstellrichtung (Y) der Schuhtragvorrichtung (3) zueinander quer und bevorzugter Weise senkrecht liegen.
8. Vorrichtung nach einem beliebigen der voranstehenden Ansprüche, **dadurch gekennzeichnet, dass** der Kopfblock einen am Stützrahmen angreifenden Tragkörper (9) und einen Bearbeitungskopf (11) umfasst, der am Tragkörper (9) verschwenkbar angebracht ist, wobei das erste und das zweite Bearbeitungswerkzeug (7, 8) am Arbeitskopf (11) angreifen.
9. Vorrichtung nach einem beliebigen der voranstehenden Ansprüche, **dadurch gekennzeichnet, dass** mindestens eines der Bearbeitungswerkzeuge (7, 8) und bevorzugter Weise beide eine im wesentlichen scheibenförmige Ausbildung besitzt, wobei die Verstellmittel (12) auf die scheibenförmigen Bearbeitungswerkzeuge (7, 8) wirken, um sie um eine entsprechende Längsachse (7a, 8a) herum zu drehen.
10. Vorrichtung nach einem beliebigen der voranstehenden Ansprüche, **dadurch gekennzeichnet, dass** die Verstellmittel auf die Bearbeitungswerkzeuge (7, 8) wirken, um sie um eine zur Arbeitsachse der Maschine parallelen Achse (7b, 8b) zu drehen.
11. Vorrichtung nach Anspruch 9 und 10, **dadurch gekennzeichnet, dass** die Drehlängsachse (7a, 8a) der scheibenförmigen Bearbeitungswerkzeuge (7, 8) zur Maschinenbearbeitungsachse quer und bevorzugter Weise senkrecht liegt.
12. Vorrichtung nach Anspruch 8, **dadurch gekennzeichnet, dass** sie überdies Dämpfungsmittel (42) um-

- fasst, die zwischen dem Arbeitskopf (11) und dem Tragkörper (9) zwischengeschaltet sind, um die Erzeugung von Schwingungen während der Schwingungsbewegungen des Bearbeitungskopfes (11) zu vermeiden.
13. Vorrichtung nach Anspruch 12, **dadurch gekennzeichnet, dass** die Dämpfungsmittel (41) umfassen:
- einen dem Bearbeitungskopf 11 zugeordneten Zylinder (42), der mit einem mit einer viskosen Flüssigkeit gefüllten Hohlraum versehen ist; und
  - einen Läufer (43), der innerhalb des Hohlraums beweglich und an einer Stange (44) starr festgesetzt ist, die am Tragkörper (9) angreift, wobei der Läufer (43) mit einer Innenwand des Zylinders (42) zwei Hohlräume festlegt, die über einen Durchströmraum (45) fluidmäßig kommunizieren.
14. Vorrichtung nach Anspruch 8, **dadurch gekennzeichnet, dass** sie Federmittel (46) umfasst, die wirksam zwischen dem Tragkörper (9) und dem Arbeitskopf (11) zwischengeschaltet sind und wirksam auf diesen letzteren im Bereich einer Stellung höchster Neigung des Arbeitskopfes selbst (11) einwirken.
15. Vorrichtung nach Anspruch 14, **dadurch gekennzeichnet, dass** die Federmittel (46) mindestens eine Feder umfassen.
16. Vorrichtung nach Anspruch 14, **dadurch gekennzeichnet, dass** die Federmittel (46) mindestens ein pneumatisches Stellglied umfassen, wobei das pneumatische Stellglied einfach und/oder doppelwirkend ist.
17. Vorrichtung nach Anspruch 16, **dadurch gekennzeichnet, dass** es überdies Druckkontrollmitteln umfasst, die mit dem pneumatischen Stellantrieb wirksam zusammenhängen, um dessen Betriebsparameter zu bestimmen.
18. Vorrichtung nach einem beliebigen der voranstehenden Ansprüche, **dadurch gekennzeichnet, dass** der Kopfblock (6) umfasst:
- ein Gehäuse, das dazu bestimmt ist, mindestens teilweise die Bearbeitungswerkzeuge (7, 8) zu umgeben;
  - mindestens eine erste und eine zweite Ansaugleitung, die am Gehäuse in Eingriff stehen und einem entsprechenden Bearbeitungswerkzeug (7, 8) zugeordnet sind; und
  - Ansaugmittel, die auf die Ansaugleitungen wirksam sind, um einen Unterdruck in demselben zu verursachen.
19. Vorrichtung nach Anspruch 18, **dadurch gekennzeichnet, dass** sie überdies eine Wählvorrichtung umfasst, die fähig ist, die Ansaugmittel derart zu aktivieren, dass sie auf einem/oder beide Ansaugleitungen wirken, wobei die Wählvorrichtung selektiv die Ansaugung an einem oder beiden Ansaugleitungen unterbricht.
20. Vorrichtung nach Anspruch 8, **dadurch gekennzeichnet, dass** der Bearbeitungskopf (11) Positioniermittel (22) umfasst, die auf jenen der Bearbeitungswerkzeuge (7, 8) wirken, um einen aktiven Abschnitt (23) derselben in den Bereich einer Arbeitsebene zu bringen, wobei die Arbeitsebene bevorzugter Weise eine Schwingachse (W) des Arbeitskopfes (11) enthält.
21. Vorrichtung nach Anspruch 20, **dadurch gekennzeichnet, dass** die Positioniermittel (22) pro Bearbeitungswerkzeug mindestens eine erste und eine zweite Koppelstange (24, 25) umfassen, die jeweilige Abschnitte aufweisen, die einerseits am Arbeitskopf (11) und andererseits an einem Werkzeugträger (26, 27) angelenkt sind, und eine Verstellvorrichtung umfassen, die auf die Koppelstangen (24, 25) wirkt, um Auf- und Abwärtsverschiebungen des aktiven Abschnittes (23) der Bearbeitungswerkzeuge (7, 8) zu bewirken.
22. Vorrichtung nach einem beliebigen der voranstehenden Ansprüche, **dadurch gekennzeichnet, dass** die Verstellmittel umfassen:
- einen Motor (13);
  - erste Übertragungsorgane (14) zur Übertragung der Bewegung vom Motor (13) auf mindestens einer am Bearbeitungskopf (11) angebrachten Scheibe (15); und
  - zweite Übertragungsorgane (16) zur Übertragung der Bewegung von der Scheibe (15) an das erste und das zweite Bearbeitungswerkzeug (7, 8).
23. Vorrichtung nach Anspruch 22, **dadurch gekennzeichnet, dass** die ersten Bewegungsübertragungsorgane (14) umfassen:
- eine erste Scheibe (18);
  - ein erstes, biegsames Element (17), bevorzugter Weise einen Zahnriemen, der in der Lage ist, eine Bewegung vom Motor (13) auf die erste Scheibe (18) zu übertragen;
  - eine zweite an der ersten Scheibe (18) festliegende Scheibe (19);
  - eine dritte Scheibe (21);
  - ein zweites biegsames Element (20), bevorzugter Weise einen Zahnriemen, der in der Lage ist die Bewegung von der zweiten Scheibe (19)

- auf die dritte Scheibe (21) zu übertragen;  
 - mindestens einen Kegeltrieb, der ein erstes der dritten Scheibe (21) wirksam zugeordnetes Zahnrad und ein zweites Zahnrad umfasst, das der am Bearbeitungskopf (11) angebrachten Scheibe (15) zugeordnet ist.
- 5
24. Vorrichtung nach Anspruch 22, **dadurch gekennzeichnet, dass** die zweiten Übertragungsorgane (16) pro Bearbeitungswerkzeug umfassen:
- einen Drehkopf (29), der über die am Bearbeitungskopf (11) angebrachte Scheibe (15) drehangetrieben wird;
  - eine erste Welle (31), die vom Kopf (29) eine Drehbewegung erhält und mit einem Innenhohlraum versehen ist;
  - eine zweite Welle (33), die verstellbar im Hohlraum der ersten Welle (31) eingreift, wobei die erste Welle (31) die Form der Abschnitte (34) aufweist, um ein Drehmoment der zweiten Welle (32) zu übertragen; und
  - ein biegsames Verbindungselement (35), das von der ersten Welle (31) aufgewiesen wird und fähig ist, relative Verschiebungen in einer vertikalen Ebene zwischen einer Drehachse (36) des Kopfes (29) und einer Drehachse (27) der zweiten Welle (33) zu erlauben.
- 10
25. Vorrichtung nach Anspruch 8, **dadurch gekennzeichnet, dass** während der Bearbeitungsschritte der Vorrichtung die Bearbeitungswerkzeuge (7, 8) beide am Bearbeitungskopf (11) festliegend beweglich sind.
- 15
26. Vorrichtung nach Anspruch 10, **dadurch gekennzeichnet, dass** die Bearbeitungswerkzeuge (7, 8) um den zur Bearbeitungsachse der Maschine parallelen Achsen (7b, 8b) gleichzeitig und festliegend drehen.
- 20
27. Vorrichtung nach Anspruch 10, **dadurch gekennzeichnet, dass** die Verstellmittel umfassen:
- einen dem Stützrahmen (12) wirksam zugeordneten Motor (38);
  - ein biegsames Übertragungselement (39), das vom Motor (38) eine Drehbewegung erfährt und in der Lage ist, dessen Übertragung auf den am Bearbeitungskopf (11) angebrachten Bearbeitungswerkzeuge (7, 8) zu erlauben.
- 25
28. Vorrichtung nach Anspruch 27, **dadurch gekennzeichnet, dass** die Verstellmittel (12) überdies umfassen:
- einen zwischen dem Motor (38) und dem biegsamen Element (39) zwischengeschalteten Ke-
- 30
31. Vorrichtung nach einem beliebigen der voranstehenden Ansprüche, **dadurch gekennzeichnet, dass** sie zwei oder mehrere Schuhtragvorrichtungen (3) umfasst, die dem Stützrahmen (2) wirksam zugeordnet sind.
- 35
30. Vorrichtung nach einem beliebigen der voranstehenden Ansprüche, **dadurch gekennzeichnet, dass** das erste und das zweite Bearbeitungswerkzeug unter den Aufrau-, Niet-, Grobbearbeitungs- und Leimwerkzeugen gewählt werden.
- 40
31. Vorrichtung nach Anspruch 30, **dadurch gekennzeichnet, dass** das erste und das zweite Bearbeitungswerkzeug ersetzbar und miteinander austauschbar sind, um mindestens den Zusammenbau eines Niet- Aufrau-, Leim-Aufrau-, Aufrau-Aufrau-, Niet-Leim-, Niet-Grobbearbeitungs-, Grobbearbeitungs-Leim-, Grobbearbeitungs-Grobbearbeitungsgerätes erlaubt wird.
- 45
32. Vorrichtung nach Anspruch 1, **dadurch gekennzeichnet, dass** eines der Bearbeitungswerkzeuge ein Leimwerkzeug ist, wobei dieses Werkzeug durch Einwirkung der Verstellmittel um mindestens eine Achse herum (8c) verschwenkbar ist.
- 50
33. Vorrichtung zur Schuhherstellung nach Anspruch 1, **dadurch gekennzeichnet, dass** sie einen Stützrahmen (2) mindestens eine wirksam dem Stützrahmen (2) zugeordnete Schuhtragvorrichtung (3), einen am Stützrahmen (2) angreifenden Kopfblock (6), mindestens ein zur Bearbeitung eines Schuhs (5) bereitgestelltes Bearbeitungswerkzeug (7) und dem Rahmen (2) zugeordnete Verstellmittel (12), die eine Relativverschiebung zwischen der Schuhtragvorrichtung (3) und dem Bearbeitungswerkzeug (7) bewirken, wobei das Bearbeitungswerkzeug (7) bezüglich des Schuhs (5) gemäß mindestens drei Achsen (X, Y, Z) beweglich ist, die zueinander im wesentlichen senkrecht liegen und um eine im wesentlichen horizontale Achse verschwenkbar ist.
- 55

#### Revendications

1. Machine destinée à la fabrication des chaussures, comprenant:

- un bâti support (2);
  - au moins un dispositif de soutien de la chaussure (3) associé de manière opérante au bâti support (2);
  - un bloc-tête (6) engagé audit bâti support (2);
  - au moins un premier et un deuxième outils de travail (7, 8) destinés à opérer sur une chaussure (5); et
  - des moyens d'entraînement (12) associés au bâti (2) et mis en marche pour permettre un déplacement relatif entre le dispositif de soutien de la chaussure (3) et les outils de travail (7, 8), **caractérisée en ce que** lesdits premier et deuxième outils de travail (7, 8) sont montés tous les deux sur le bloc-tête (6).
2. Machine selon la revendication 1, **caractérisée en ce que** le dispositif de soutien de la chaussure comporte des moyens (4) pour bloquer ladite chaussure (5), ces moyens étant mobiles entre au moins une condition opérante à laquelle ils maintiennent la chaussure (5) en position pour effectuer le travail et une deuxième condition opérante à laquelle ils libèrent la chaussure (5) pour effectuer une opération de chargement-déchargement.
3. Machine selon l'une quelconque des revendications précédentes, **caractérisée en ce que** le dispositif de soutien de la chaussure (3) est mobile par rapport au bâti support (2) dans au moins une première (X) et une deuxième (Y) directions transversales l'une à l'autre.
4. Machine selon la revendication 3, **caractérisée en ce que** la première direction de mouvement (Z) du dispositif de soutien de la chaussure (3) est coïncidente avec un axe sensiblement vertical et ladite deuxième direction de mouvement (Y) est disposée dans un plan essentiellement horizontal.
5. Machine selon l'une quelconque des revendications précédentes, **caractérisée en ce que** le bloc-tête (6) est mobile dans au moins une direction de mouvement (X) disposée dans un plan sensiblement horizontal.
6. Machine selon l'une quelconque des revendications précédentes, **caractérisée en ce que** le bloc-tête (6) est mobile dans une direction de mouvement (Z), ladite direction de mouvement (Z) étant de préférence transversale, et de manière encore plus préférentielle perpendiculaire, aux axes (X) et/ou (Y).
7. Machine selon l'une quelconque des revendications 3 et 5, **caractérisée en ce que** la direction de mouvement (X) du bloc-tête (6) et la deuxième direction de mouvement (Y) du dispositif de soutien de la chaussure (3) sont transversales, et de préférence
- perpendiculaires, l'une à l'autre.
8. Machine selon l'une quelconque des revendications précédentes, **caractérisée en ce que** le bloc-tête (6) comporte un corps d'appui (9) engagé au bâti support et une tête de travail (11) montée de manière oscillante sur le corps d'appui (9), lesdits premier et deuxième outils (7, 8) étant engagés à ladite tête de travail (11).
9. Machine selon l'une quelconque des revendications précédentes, **caractérisée en ce qu'**au moins un desdits outils de travail (7, 8), et de préférence tous les deux, ont une conformation sensiblement en forme de disque, lesdits moyens d'entraînement (12) étant actifs sur les outils de travail en forme de disque (7, 8) pour les entraîner en rotation autour d'un axe longitudinal respectif (7a, 8a).
10. Machine selon l'une quelconque des revendications précédentes, **caractérisée en ce que** les moyens d'entraînement sont actifs sur les outils de travail (7, 8) pour les entraîner en rotation autour d'un axe (7b, 8b) parallèle à l'axe d'usinage.
11. Machine selon les revendications 9 et 10, **caractérisée en ce que** ledit axe de rotation longitudinal (7a, 8a) des outils en forme de disque (7, 8) est transversal, et de préférence orthogonal, à l'axe d'usinage.
12. Machine selon la revendication 8, **caractérisée en ce qu'**elle comporte en outre des moyens amortisseurs (41) interposés de manière opérante entre la tête de travail (11) et le corps d'appui (9) pour éviter que des vibrations soient engendrées pendant les mouvements d'oscillation de la tête de travail (11).
13. Machine selon la revendication 12, **caractérisée en ce que** les moyens amortisseurs (41) comportent:
- un cylindre (41) associé à la tête de travail (11) et muni d'une cavité remplie d'un fluide visqueux; et
  - un curseur (43) mobile dans la cavité et uni rigidement à une tige (44) reliée au corps d'appui (9), ledit curseur (43) définissant ensemble avec la paroi intérieure dudit cylindre (42) deux zones dans ladite cavité lesquelles sont en communication de fluide l'une avec l'autre à travers un espace de coulage (45).
14. Machine selon la revendication 8, **caractérisée en ce qu'**elle comporte des moyens élastiques (46) interposés de manière opérante entre le corps d'appui (9) et la tête de travail (11) et actifs de manière opérante sur ladite tête à une position d'inclinaison maximum de la tête de travail (11) elle-même.

15. Machine selon la revendication 14, **caractérisée en ce que** lesdits moyens élastiques (46) comportent au moins un ressort.
16. Machine selon la revendication 14, **caractérisée en ce que** les moyens élastiques (46) comportent au moins un dispositif d'entraînement pneumatique, ledit dispositif d'entraînement pneumatique étant du type à simple effet ou à double effet.
17. Machine selon la revendication 16, **caractérisée en ce qu'elle** comporte en outre des moyens de réglage de la pression asservis de manière opérante au dispositif d'entraînement pneumatique pour établir les paramètres de fonctionnement de ce dernier.
18. Machine selon l'une quelconque des revendications précédentes, **caractérisée en ce que** le bloc-tête (6) comporte:
- une enveloppe destinée à entourer les outils de travail (7, 8);
  - au moins un premier et un deuxième conduit d'aspiration reliés à l'enveloppe et associés à un outil de travail (7, 8) respectif; et
  - des moyens d'aspiration actifs sur lesdits conduits pour créer le vide dans ces derniers.
19. Machine selon la revendication 18, **caractérisée en ce qu'elle** comporte en outre un dispositif sélecteur en mesure de mettre en marche les moyens d'aspiration pour agir sur un des conduits d'aspiration et/ou sur tous les deux, ledit dispositif sélecteur interrompant sélectivement l'aspiration sur un des conduits d'aspiration ou sur tous les deux.
20. Machine selon la revendication 8, **caractérisée en ce que** la tête de travail (11) comporte des moyens de positionnement (22) actifs sur chacun des outils de travail (7, 8) pour amener la portion active (23) de ces derniers à proximité d'un plan de travail, ledit plan de travail contenant de préférence un axe d'oscillation (W) de la tête de travail (11).
21. Machine selon la revendication 20, **caractérisée en ce que** les moyens de positionnement (22) comportent, pour chaque outil, au moins une première et une deuxième bielle (24, 25) ayant des portions respectives articulées d'un côté sur la tête de travail (11) et de l'autre côté sur un support porte-outil (26, 27), et un dispositif d'entraînement actif sur lesdites bielles (24, 25) pour causer des déplacements vers le haut/vers le bas de la portion active (23) des outils (7, 8).
22. Machine selon l'une quelconque des revendications précédentes, **caractérisée en ce que** les moyens d'entraînement comportent:
- un moteur (13);
  - des premiers organes de transmission du mouvement (14) du moteur jusqu'au moins une poulie (15) montée sur la tête de travail (11); et
  - des deuxième organes (16) de transmission du mouvement de la poulie (15) auxdits premier et deuxième outils de travail (7, 8).
23. Machine selon la revendication 22, **caractérisée en ce que** les premiers organes de transmission du mouvement (14) comportent:
- une première poulie (18);
  - un premier élément flexible (17), de préférence une courroie dentée, en mesure de transmettre le mouvement depuis le moteur (13) jusqu'à la première poulie (18);
  - une deuxième poulie (19) solidaire de ladite première poulie (18);
  - une troisième poulie (21);
  - un deuxième élément flexible (20), de préférence une courroie dentée, en mesure de transmettre le mouvement depuis la deuxième poulie (19) jusqu'à la troisième poulie (21);
  - au moins un couple conique comprenant un premier engrenage associé de manière opérante à la troisième poulie (21) et un deuxième engrenage associé de manière opérante à la poulie (15) montée sur la tête de travail (11).
24. Machine selon la revendication 22, **caractérisée en ce que** les deuxième organes de transmission du mouvement (16) comportent, pour chaque outil:
- une tête tournante (29) entraînée en rotation par la poulie (15) montée sur la tête de travail (11);
  - un premier arbre (31) recevant un mouvement rotatoire de la tête tournante (29) et muni d'une cavité intérieure;
  - un deuxième arbre (33) engagé de manière coulissante dans ladite cavité du premier arbre (31), ledit premier arbre (31) ayant des portions conformées (34) pour la transmission d'un moment d'un couple au deuxième arbre (33); et
  - un élément de liaison flexible (35) présent sur ledit premier arbre (31) et en mesure de permettre des déplacements relatifs dans un plan vertical entre un axe de rotation (36) de la tête tournante (29) et un axe de rotation (27) du deuxième arbre (33).
25. Machine selon la revendication 8, **caractérisée en ce que** pendant les étapes de travail de la machine les outils (7, 8) sont tous les deux mobiles, étant solidaires de la tête de travail (11).
26. Machine selon la revendication 10, **caractérisée en**

**ce que** les outils (7, 8) tournent autour des axes (7b, 8b) parallèles à l'axe d'usinage d'une façon solidaire et simultanée.

27. Machine selon la revendication 10, **caractérisée en ce que** les moyens d'entraînement comportent:

- un moteur (38) associé de manière opérante au bâti support (12);
- un élément flexible de transmission du mouvement (39) recevant un mouvement rotatoire dudit moteur (38) et en mesure de permettre le transfert dudit mouvement aux outils (7, 8) montés sur la tête de travail (11).

28. Machine selon la revendication 27, **caractérisée en ce que** les moyens d'entraînement (12) comportent en outre:

- un couple conique interposé entre le moteur (38) et l'élément flexible (39), un premier engrenage dudit couple conique recevant un mouvement rotatoire du moteur et transférant ce mouvement à un deuxième engrenage solidaire de l'élément flexible; et
- une tête tournante (40) montée directement sur la tête de travail oscillante (11) et recevant le mouvement de l'élément flexible (39).

29. Machine selon l'une quelconque des revendications précédentes, **caractérisée en ce qu'elle** comporte deux ou plusieurs dispositifs de soutien de la chaussure (3) associés de manière opérante au bâti support (2).

30. Machine selon l'une quelconque des revendications précédentes, **caractérisée en ce que** lesdits premier et deuxième outils sont choisis parmi des outils de cardage, rivetage, dégrossissage et encollage.

31. Machine selon la revendication 30, **caractérisée en ce que** lesdits premier et deuxième outils sont remplaçables et interchangeables les uns avec les autres pour permettre au moins l'assemblage d'une machine de rivetage-cardage, de cardage-encollage, de cardage-cardage, de rivetage-encollage, de rivetage-dégrossissage, de dégrossissage-encollage, de dégrossissage-dégrossissage.

32. Machine selon la revendication 1, **caractérisée en ce que** l'un desdits outils est un outil d'encollage; ledit outil étant mobile de manière oscillante sous l'action des moyens d'entraînement autour d'au moins un axe (8c).

33. Machine pour la fabrication de chaussures selon la revendication 1, **caractérisée en ce qu'elle** comporte un bâti support (2), au moins un dispositif de

soutien de la chaussure (3) associé de manière opérante au bâti support (2), un bloc-tête (6) en engagement avec ledit bâti support (2), au moins un outil de travail (7) destiné à opérer sur une chaussure (5), et des moyens d'entraînement (12) associés au bâti (2) et actifs pour permettre un déplacement relatif entre le dispositif de soutien de la chaussure (3) et l'outil de travail (7), ledit outil de travail (7) étant mobile par rapport à la chaussure (5) le long d'au moins trois axes (X, Y, Z) sensiblement orthogonaux entre eux et étant susceptible d'oscillation autour d'un axe sensiblement horizontal.

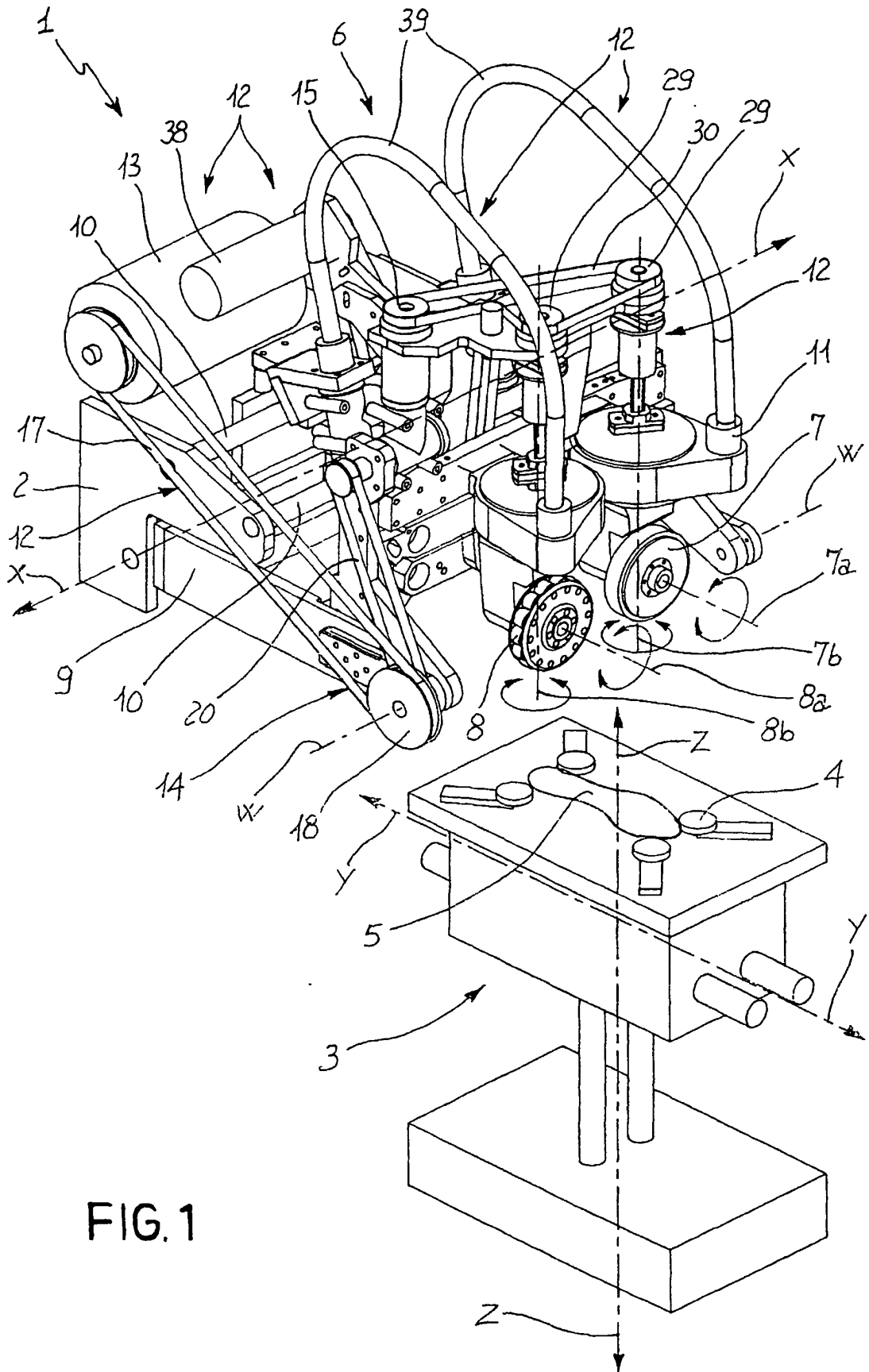

FIG. 1



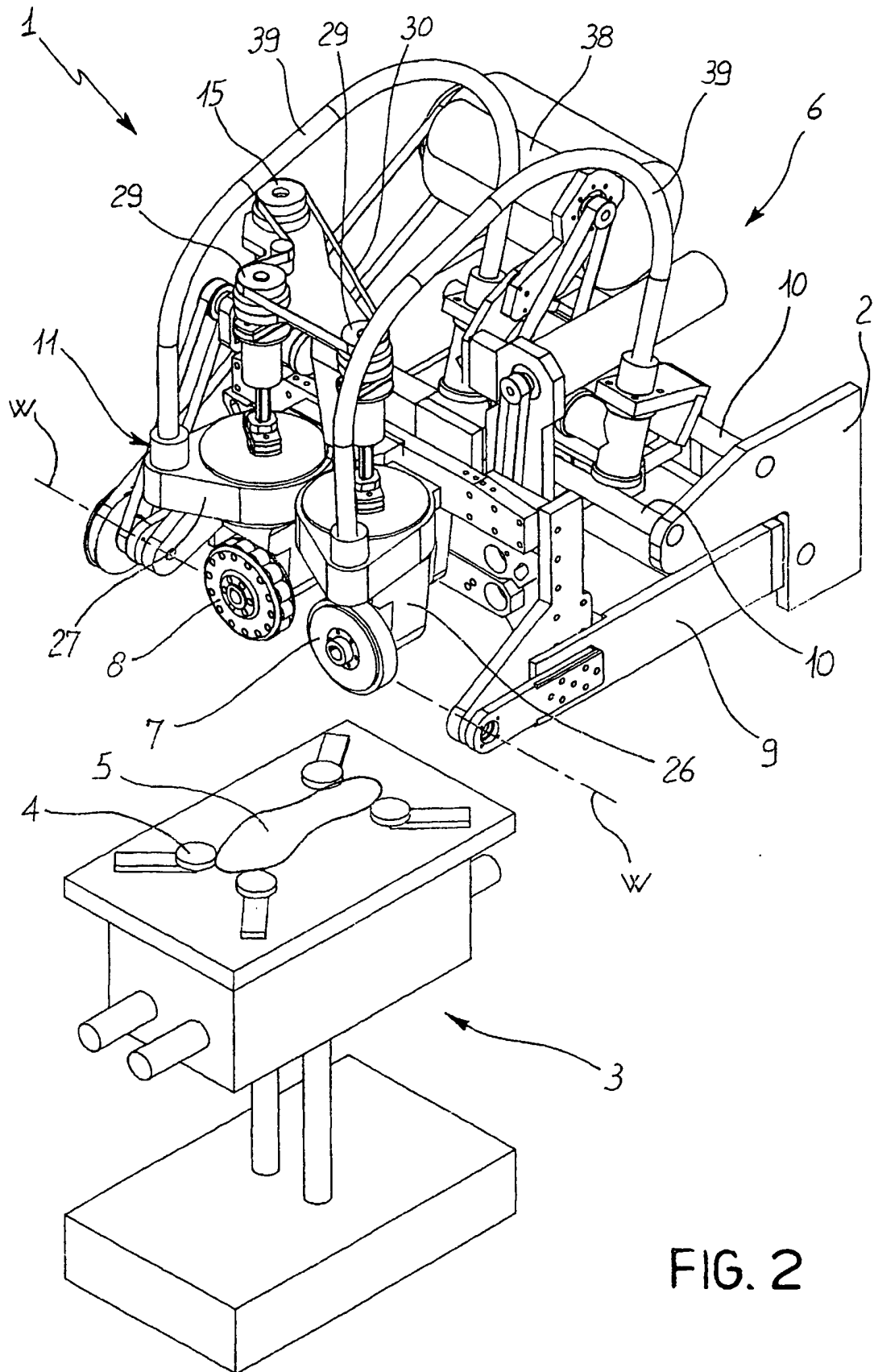

FIG. 2

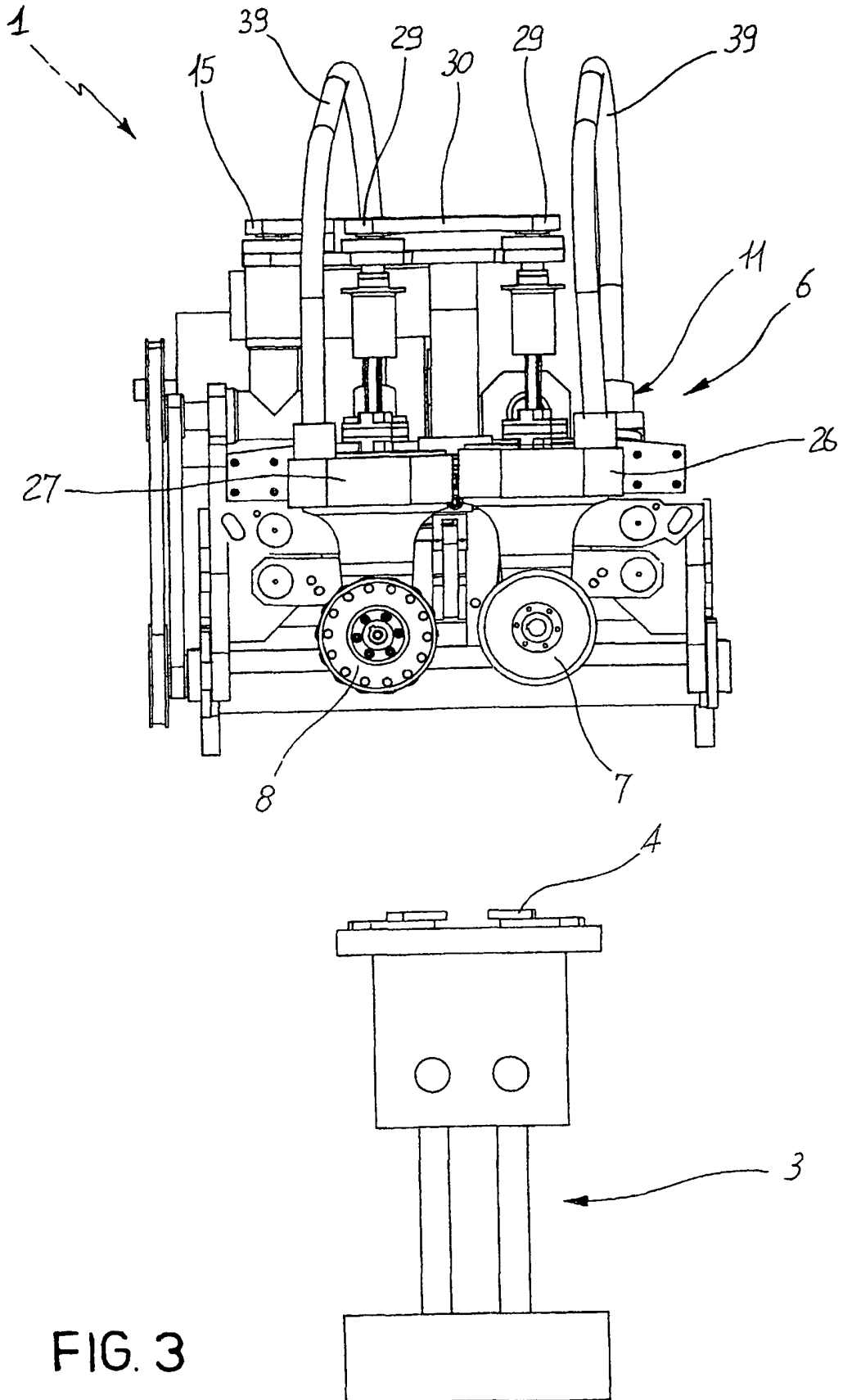

FIG. 3

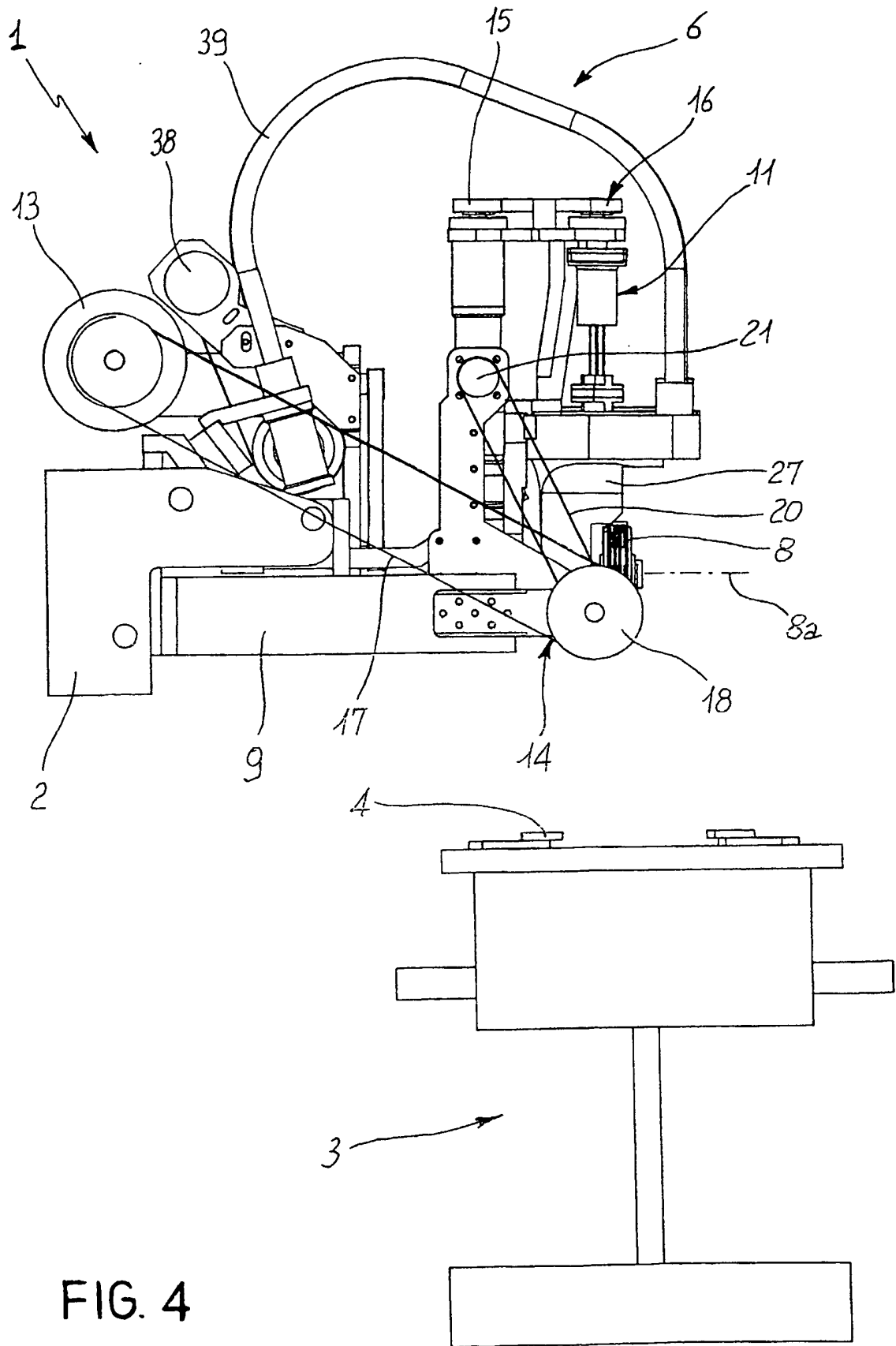

FIG. 4

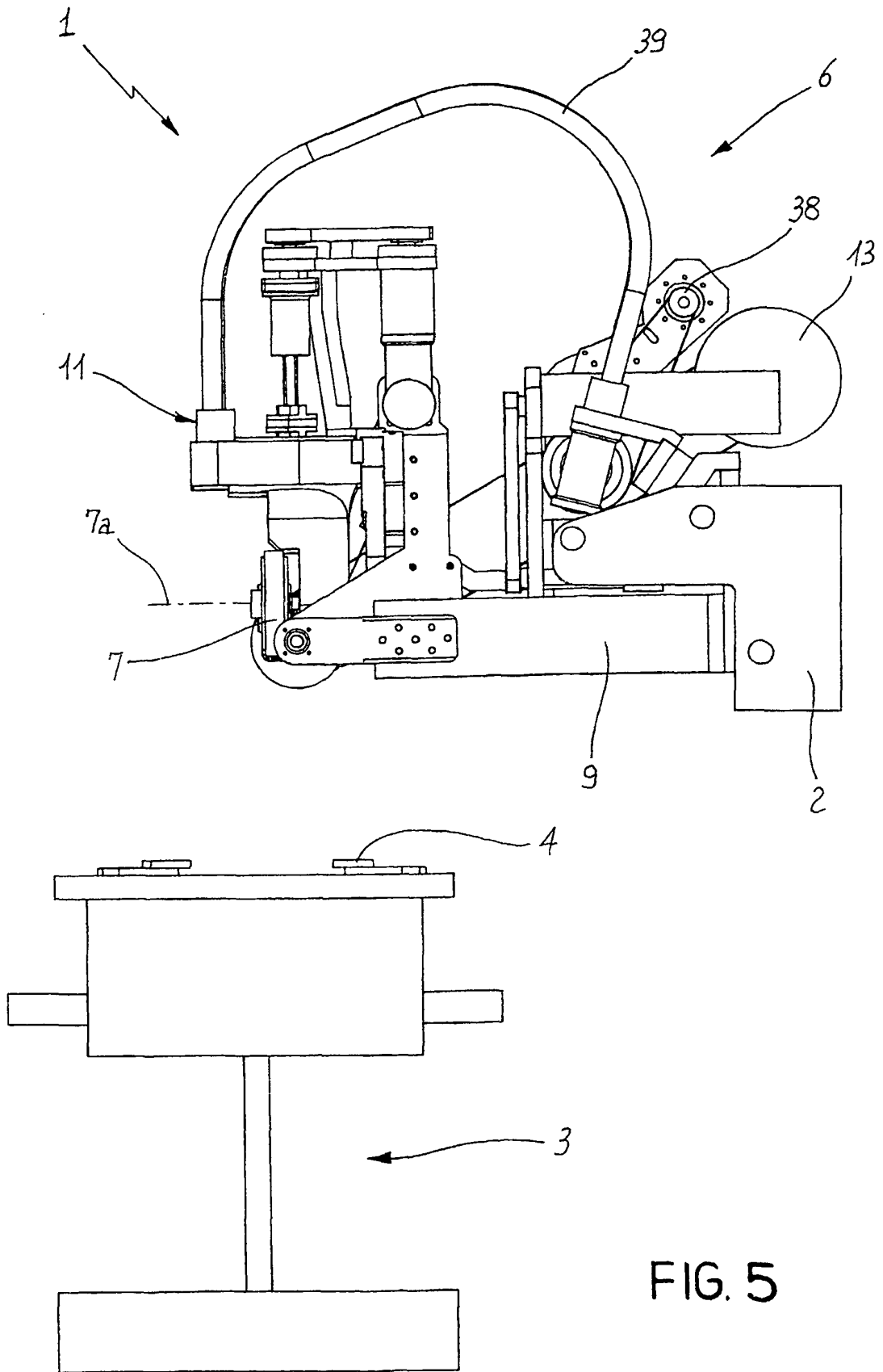
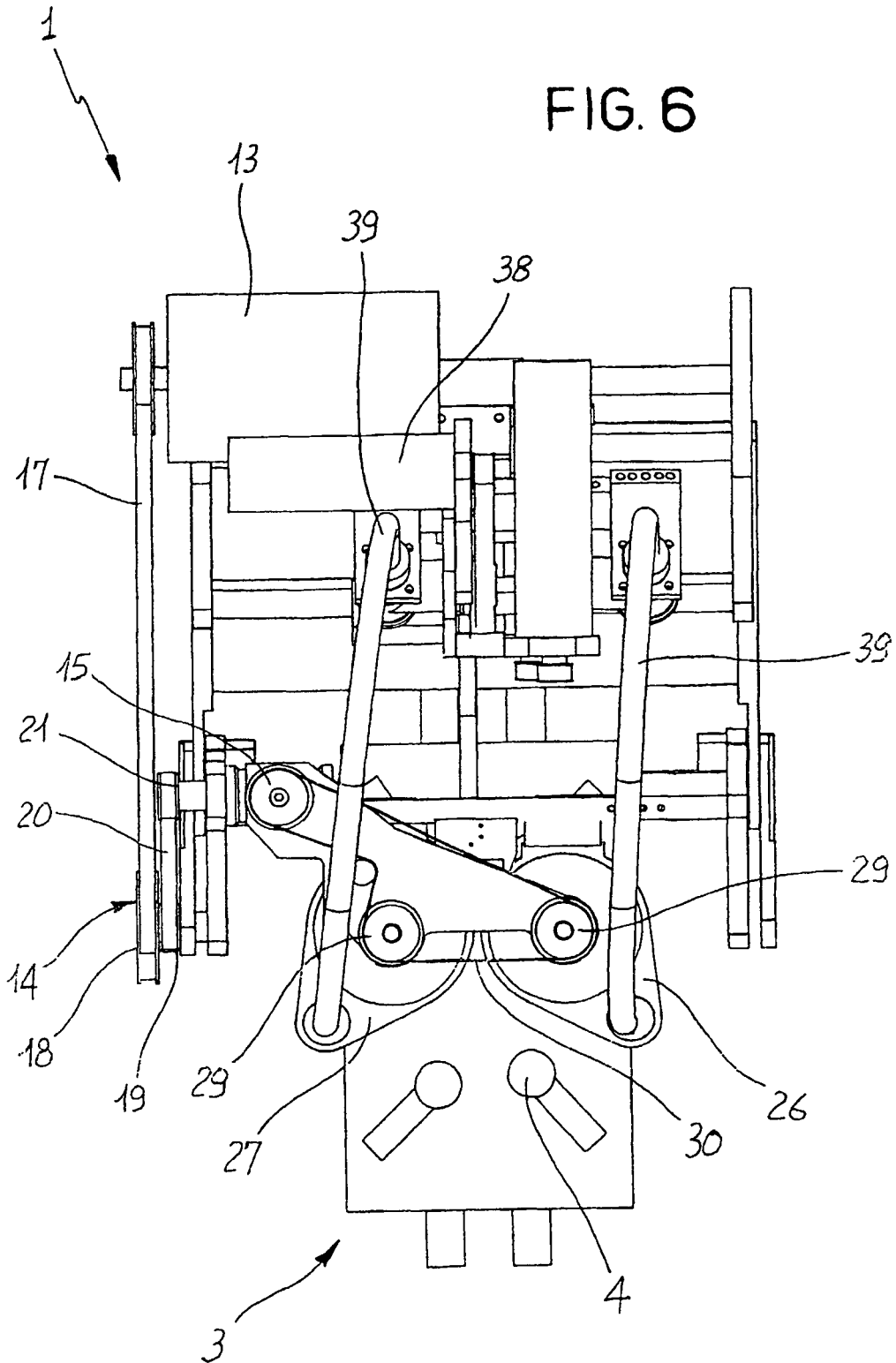
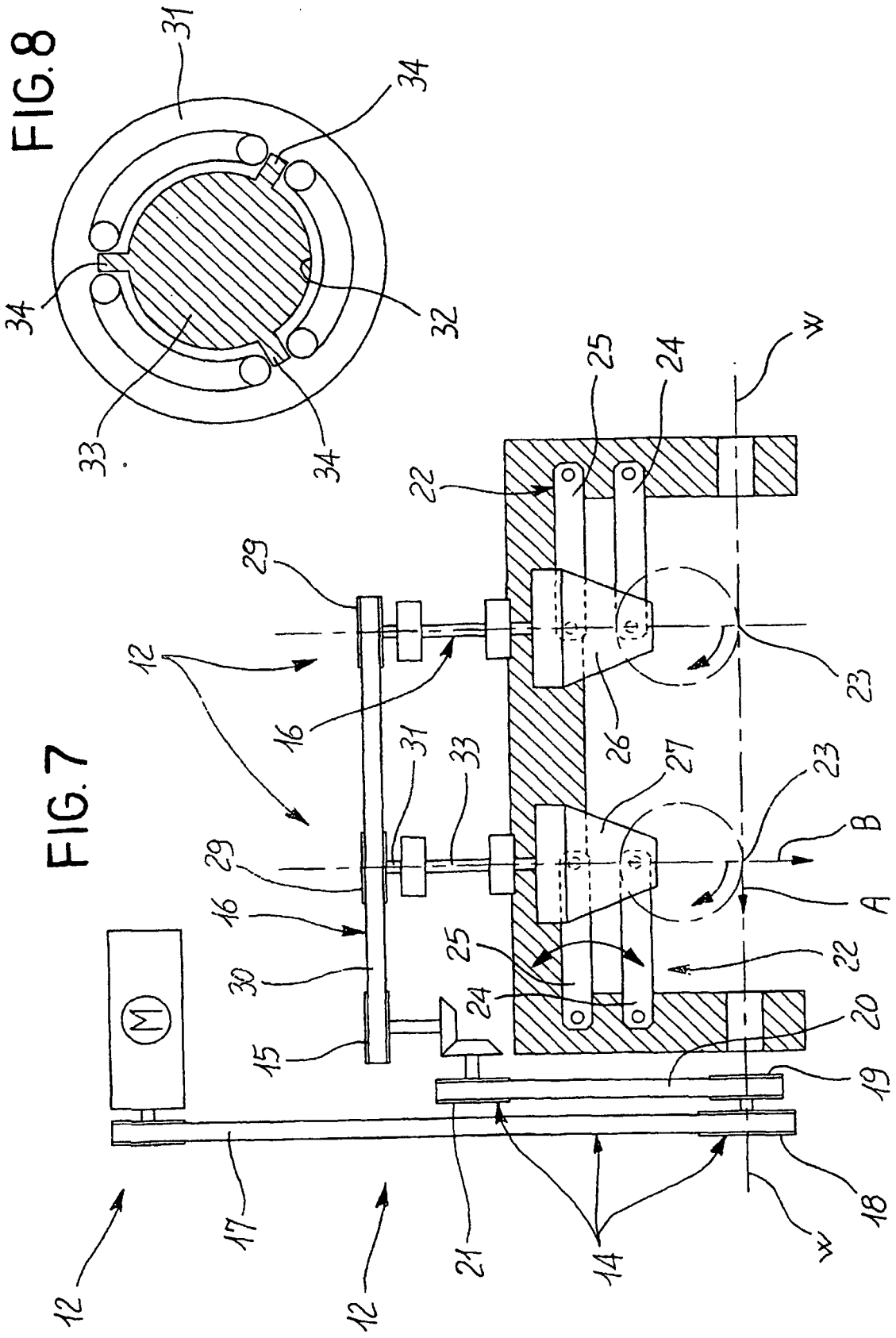

FIG. 5

FIG. 6





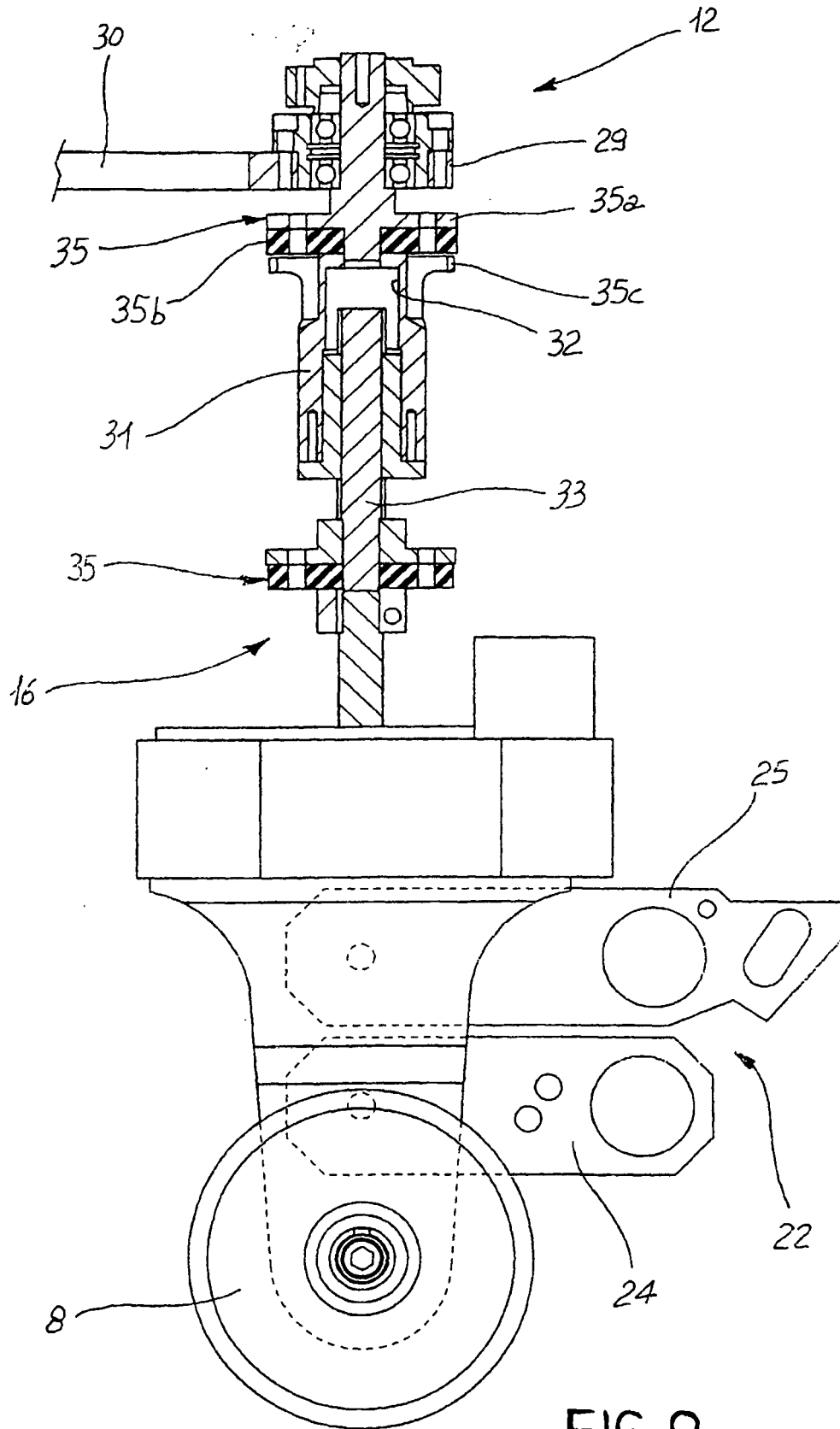
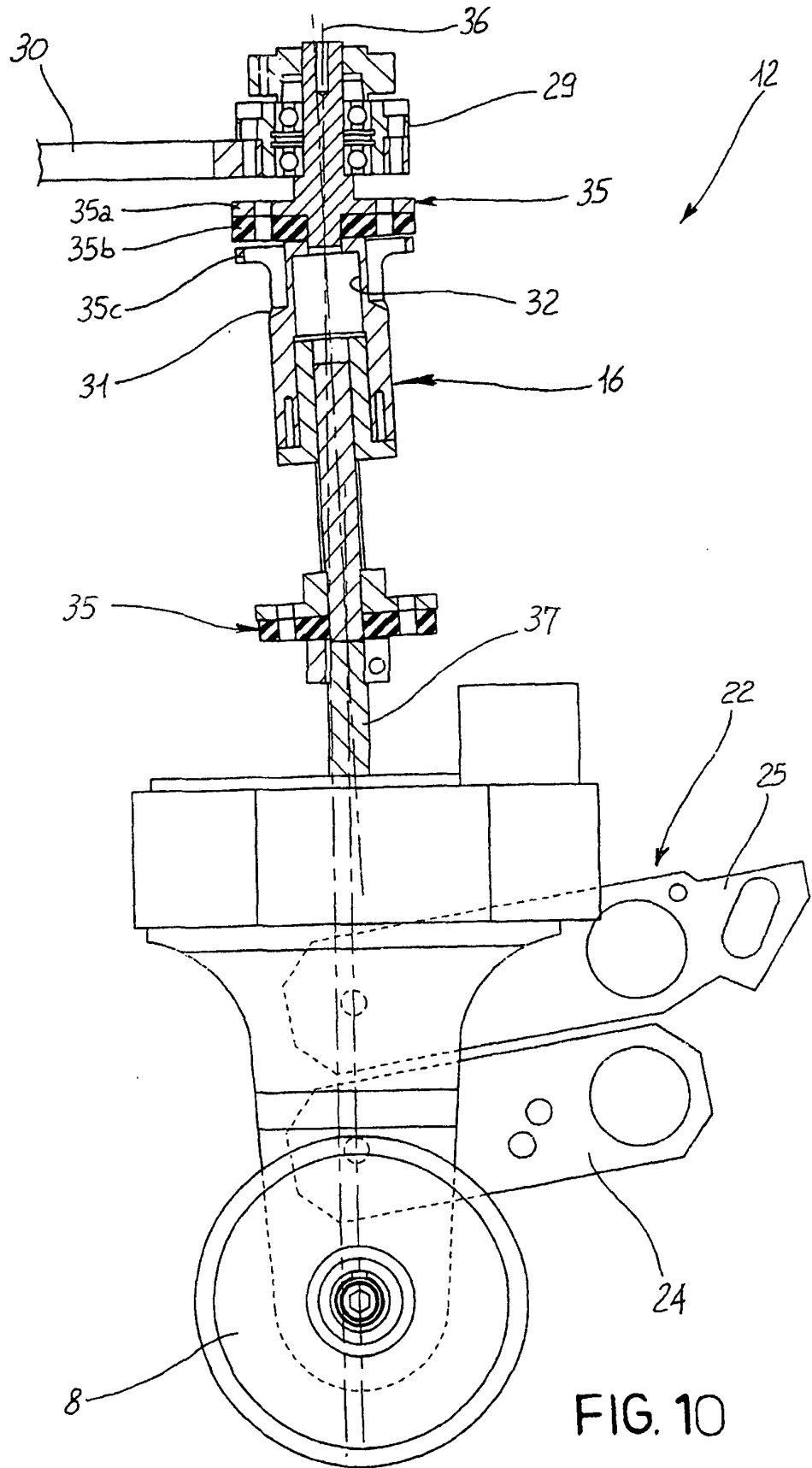

FIG. 9





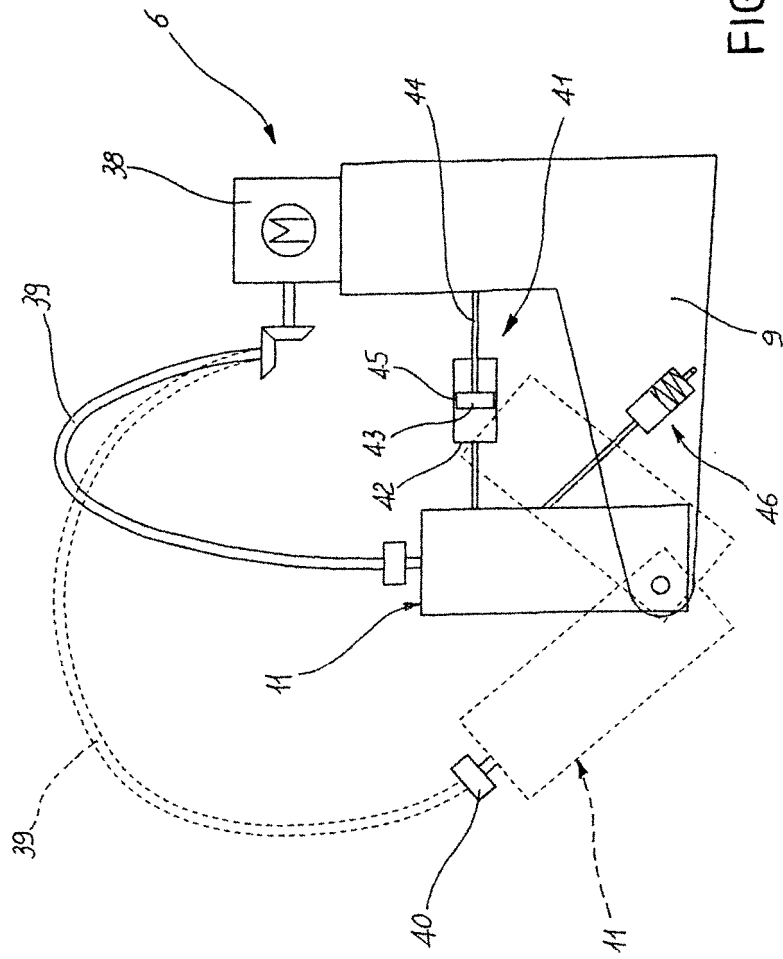

FIG. 11

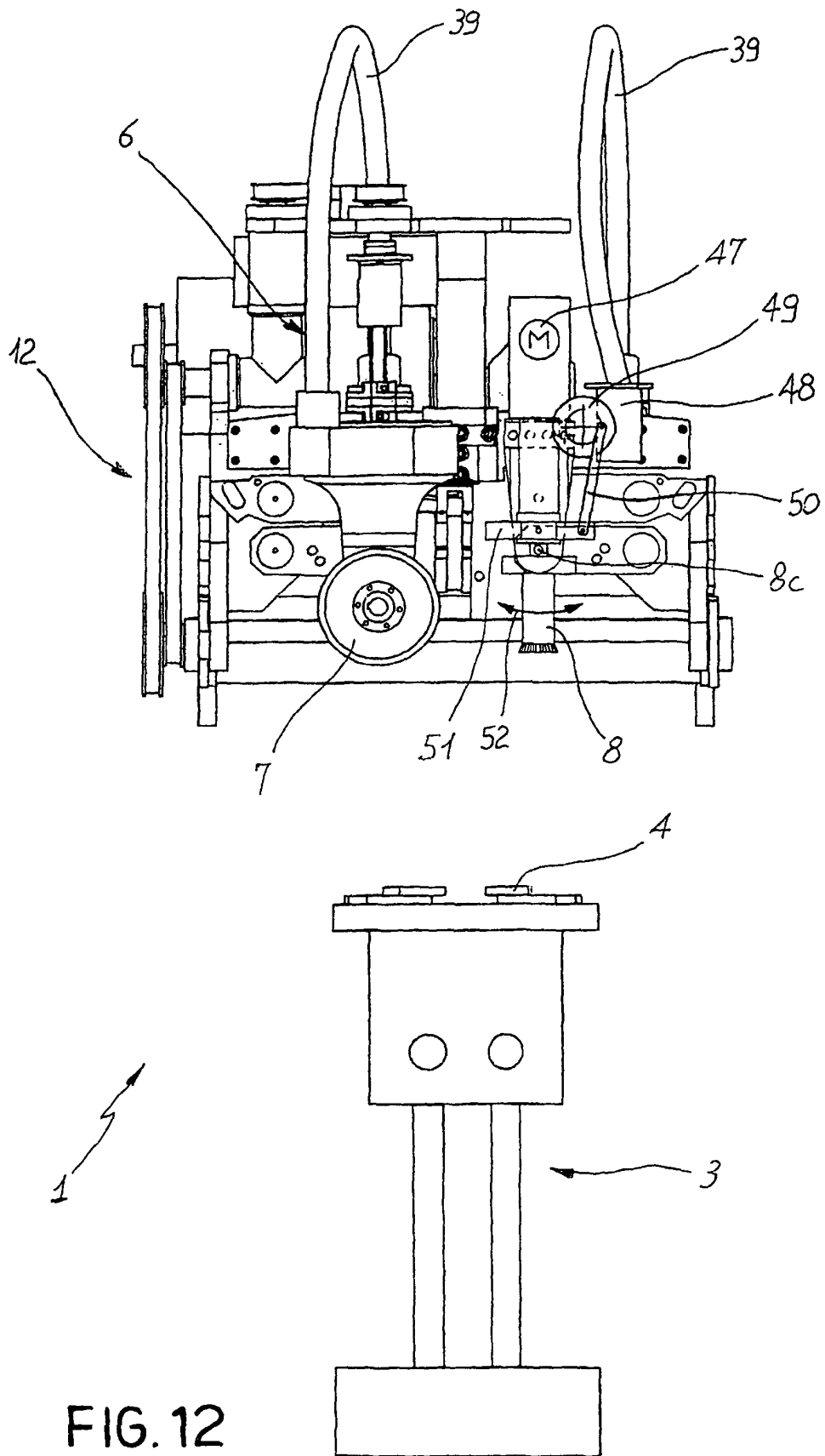

FIG. 12

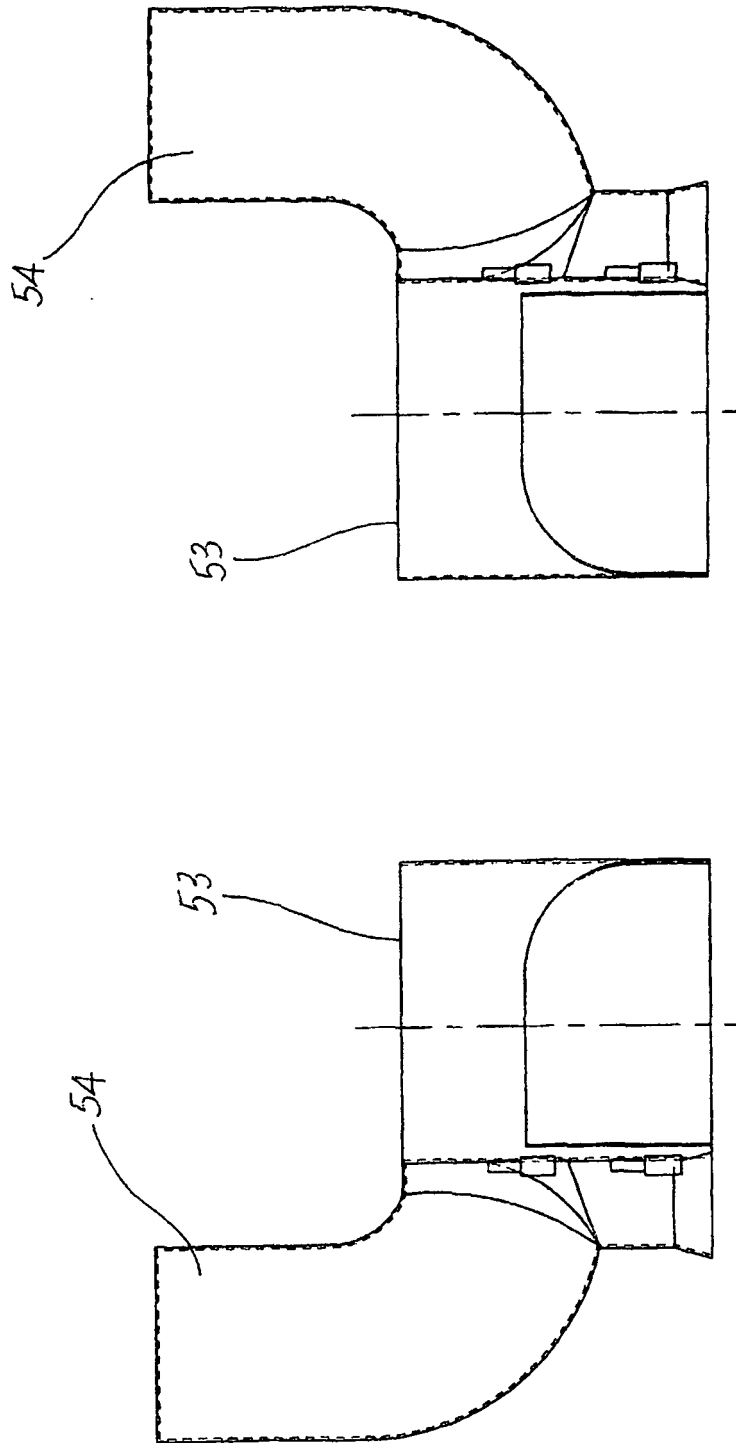

FIG. 13