



(11) **EP 1 286 019 B1**

(12) **EUROPEAN PATENT SPECIFICATION**

(45) Date of publication and mention of the grant of the patent:
22.04.2009 Bulletin 2009/17

(51) Int Cl.:
E21B 33/12^(2006.01)

(21) Application number: **02255754.0**

(22) Date of filing: **19.08.2002**

(54) **Expandable retaining shoe**

Aufweitbarer Schuhhalter

Sabot de retenue expansible

(84) Designated Contracting States:
DE FR GB NL

(30) Priority: **20.08.2001 US 934045**

(43) Date of publication of application:
26.02.2003 Bulletin 2003/09

(73) Proprietor: **HALLIBURTON ENERGY SERVICES, INC.**
Duncan,
Oklahoma 73536 (US)

(72) Inventors:
• **Smith, Donald R.**
Wilson, OK 73463 (US)

• **Crockford, Lloyd A.**
Houston, TX 77062 (US)
• **Winslow, Donald W.**
Duncan, OK 73533 (US)

(74) Representative: **Wain, Christopher Paul et al**
A.A. Thornton & Co.
235 High Holborn
London WC1V 7LE (GB)

(56) References cited:
EP-A- 1 197 632 **US-A- 2 368 928**
US-B1- 6 167 963

EP 1 286 019 B1

Note: Within nine months of the publication of the mention of the grant of the European patent in the European Patent Bulletin, any person may give notice to the European Patent Office of opposition to that patent, in accordance with the Implementing Regulations. Notice of opposition shall not be deemed to have been filed until the opposition fee has been paid. (Art. 99(1) European Patent Convention).

Description

[0001] This invention relates generally to downhole tools for use in wellbores and, more particularly, to such tools having a packer element, and to improvements in preventing undesired extrusion of packer seal elements between segmented non-metallic packer element shoes.

[0002] In the drilling or reworking of oil wells, a great variety of downhole tools are used. For example, but not by way of limitation, it is often desirable to seal tubing or other pipe in the casing of the well, such as when it is desired to pump cement or other slurry down the tubing and force the cement or slurry around the annulus of the tubing or out into a formation. It then becomes necessary to seal the tubing with respect to the well casing and to prevent the fluid pressure of the slurry from lifting the tubing out of the well or for otherwise isolating specific zones in which a wellbore has been placed. Downhole tools referred to as packers and bridge plugs are designed for these general purposes and are well-known in the art of producing oil and gas.

[0003] When it is desired to remove many of these downhole tools from a wellbore, it is frequently simpler and less expensive to mill or drill them out rather than to implement a complex retrieving operation. In milling a milling cutter is used to grind the packer or lug, for example, or at least the outer components thereof, out of the wellbore. Milling is a relatively slow process, but when milling with conventional tubular strings, it can be used on packers or bridge plugs having relative hard components such as erosion-resistant hard steel. One such packer is disclosed in U.S. Patent No. 4,151,875 to Sullaway, assigned to the assignee of the present invention and sold under the trademark EZ Disposal® packer.

[0004] In drilling, a drill bit is used to cut and grind up the components of the downhole tool to remove it from the wellbore. This is a much faster operation than milling, but requires the tool to be made out of materials which can be accommodated by the drill bit. Typically, soft and medium hardness cast iron are used on the pressure bearing components, along with some brass and aluminum items. Packers of this type include the Halliburton EZ Drill® and EZ Drill® Super Surge SV squeeze packers.

[0005] The EZ Drill® Super Surge SV squeeze packer, for example, includes a lock ring housing, upper slip wedge, lower slip wedge, and lower slip support made of soft cast iron. These components are mounted on a mandrel made of medium hardness cast iron. The EZ Drill® Super Surge bridge plug is also similar, except that it does not provide for fluid flow therethrough.

[0006] All of the above-mentioned packers are disclosed in Halliburton Services - Sales and Service Catalog No. 43, pages 2561-2562, and the bridge plug is disclosed in the same catalog on pages 2556-2557.

[0007] The EZ Drill® packer and bridge plug and the EZ Drill® SV packer are designed for fast removal from the wellbore by either rotary or cable tool drilling methods.

Many of the components in these drillable packing devices are locked together to prevent their spinning while being drilled, and the harder slips are grooved so that they will be broken up in small pieces. Typically, standard "tri-cone" rotary drill bits are used which are rotated at speeds of about 75 to about 120 rpm. A load of about 5,000 to about 7,000 pounds of weight is applied to the bit for initial drilling and increased as necessary to drill out the remainder of the packer or bridge plug, depending upon its size. Drill collars may be used as required for weight and bit stabilization.

[0008] Such drillable devices have worked well and provide improved operating performance at relatively high temperatures and pressures. The packers and bridge plugs mentioned above are designed to withstand pressures of about 10,000 psi (700 Kg/cm²) and temperatures of about 425° F (220° C) after being set in the wellbore. Such pressures and temperatures require using the cast iron components previously discussed.

[0009] However, drilling out iron components requires certain techniques. Ideally, the operator employs variations in rotary speed and bit weight to help break up the metal parts and reestablish bit penetration should bit penetration cease while drilling. A phenomenon known as "bit tracking" can occur, wherein the drill bit stays on one path and no longer cuts into the downhole tool. When this happens, it is necessary to pick up the bit above the drilling surface and rapidly recontact the bit with the packer or plug and apply weight while continuing rotation. This aids in breaking up the established bit pattern and helps to reestablish bit penetration. If this procedure is used, there are rarely problems. However, operators may not apply these techniques or even recognize when bit tracking has occurred. The result is that drilling times are greatly increased because the bit merely wears against the surface of the downhole tool rather than cutting into it to break it up.

[0010] In order to overcome the above long standing problems, the assignee of the present invention introduced to the industry a line of drillable packers and bridge plugs currently marketed by the assignee under the trademark FAS DRILL®. The FAS DRILL® line of tools consist of a majority of the components being made of non-metallic engineering grade plastics to greatly improve the drillability of such downhole tools. The FAS DRILL® line of tools have been very successful and a number of U.S. patents have been issued to the assignee of the present invention, including U.S. Patent No. 5,271,468 to Streich et al., U.S. Patent No. 5,224,540 to Streich et al., and U.S. Patent No. 5,390,737 to Jacobi et al.

[0011] Notwithstanding the success of the FAS DRILL® line of drillable downhole packers and bridge plugs, the assignee of the present invention discovered that certain metallic components still used within the FAS DRILL® line of packers and bridge plugs at the time of issuance of the above patents were preventing even quicker drill out times under certain conditions or when

using certain equipment. Exemplary situations include milling with conventional jointed tubulars and in conditions in which normal bit weight or bit speed could not be obtained. Other exemplary situations include drilling or milling with nonconventional drilling techniques such as milling or drilling with relatively flexible coiled tubing.

[0012] When milling or drilling with coiled tubing, which does not provide a significant amount of weight on the tool being used, even components made of relatively soft steel, or other metals considered to be low strength, create problems and increase the amount of time required to mill out or drill out a downhole tool, including such tools as the assignee's FAS DRILL® line of drillable non-metallic downhole tools.

[0013] Furthermore, packer shoes and optional back up rings made of a metallic material are employed not so much as a first choice but due to the metallic shoes and back up rings being able to withstand the temperatures and pressures typically encountered by a downhole tool deployed in a borehole.

[0014] Another shortcoming with using metallic packer shoes and optional backup rings is that upon deployment of the tool, the typically brass packer shoe may not flare outwardly as the packer portion is being compressed and therefore not expand outwardly as desired. If the brass shoe does not properly flare, it can lead to unwanted severe distortion of the shoes and subsequent cutting of the packer element which reduces its ability to hold to its rated differential pressure or lead to a complete failure of the tool.

[0015] To address the preceding shortcomings, the assignee hereof filed a U.S. patent application on May 5, 1995, Serial No. 08/442,448, which issued on May 30, 1996, as U.S. Patent No. 5,540,279 (the '279 patent), describing and claiming an improved downhole tool apparatus preferably utilizing essentially all non-metallic materials such as engineering grade plastics, resins, or composites. The '279 patent describes a wellbore packing type apparatus making use of essentially only non-metallic components in the downhole tool apparatus for increasing the efficiency of alternative drilling and milling techniques in addition to conventional drilling and milling techniques and further provided for a segmented non-metallic back-up ring in lieu of a conventional metallic packer shoe having a metallic supporting ring. The tool discussed in the '279 patent preferably employed the general geometric configuration of previously known drillable non-metallic packers and bridge plugs such as those disclosed in U.S. Patent No. 5,271,468 to Streich et al., U.S. Patent No. 5,224,540 to Streich et al., and U.S. Patent No. 5,390,737 to Jacobi et al. while replacing essentially all of the few remaining metal components of the tools disclosed in the preceding patents with non-metallic materials which can still withstand the pressures and temperatures found in many wellbore applications. In the '279 patent, the apparatus also includes specific design changes to accommodate the advantages of using essentially only plastic and composite materials and to al-

low for the reduced strengths thereof compared to metal components. Additionally, the '279 embodiment comprised a center mandrel and slip means disposed on the mandrel for grippingly engaging the wellbore when in a set position, a packing means disposed on the mandrel for sealingly engaging the wellbore when in a set position, a slip means comprising a slip wedge positioned around the center mandrel, a plurality of slip segments disposed in an initial position around the mandrel and adjacent to the slip wedge, and retaining means for holding the slip segments in an initial position. The slip segments would then expand radially outward upon being set so as to grippingly engage the wellbore. Hardened inserts can be molded, or otherwise installed into the slips, and can be metallic such as hardened steel, or non-metallic such as a ceramic material.

[0016] In the preferred embodiment of the '279 patent, the slip means included a slip wedge installed on the mandrel and the slip segments, whether retained by a retaining band or whether retained by an integral ring portion, have co-acting planar, or flat portions, which provided a superior sliding bearing surface especially when the slip means were made of a non-metallic material such as engineering grade plastics, resins, phenolics, or composites.

[0017] Furthermore, in the '279 patent prior art packer element shoes and back up rings, such as those referred to as elements 37 and 38, 44 and 45 in the present assignee's U.S. Patent No. 5,271,468, were replaced by a non-metallic packer shoe having a multitude of co-acting non-metallic segments and at least one retaining band, and preferably two non-metallic bands, for holding the shoe segments in place after initial assembly and during the running of the tool into the wellbore and prior to the setting of the associated packer element within the wellbore.

[0018] Notwithstanding the success of the invention described in the '279 patent in that tools made in accordance thereto are able to withstand the stresses induced by relatively high differential pressures and high temperatures found within wellbore environments, the assignee of the present invention discovered that when using larger packer type tools, or when using packer type tools in higher temperature and/or higher differential pressure environments, such as those having nominal diameters exceeding six (6) inches, temperatures exceeding 250° F, or differential pressures exceeding 10,000 psi, there was a possibility for the non-metallic segmented packer element back-up shoes, also referred to as back-up rings, to allow the packer element to extrude through gaps that are designed to form between the back-up ring segments upon the segments being forced radially outward toward the wellbore surface when the packer element was activated. Upon certain conditions, the larger O.D. packer elements, and smaller O.D. packer elements upon being subjected to elevated pressures and temperatures, were subject to being extruded through these gaps thereby possibly damaging the packer element and jeopardizing

the integrity of the seal between the wellbore and the packer elements.

[0019] To address the issue of unwanted extrusion, the assignee of the present invention filed a patent application on March 29, 1996, which issued as U.S. Patent No. 5,701,959 (the '959 patent) on December 30, 1997.

[0020] The '959 invention, like the '279 invention, included a non-metallic shoe having a multitude of co-acting non-metallic segments and at least one retaining band, and preferably two retaining bands for holding the shoe segments in place after initial assembly and during the running of the tool into the wellbore and prior to the sealing of the associated packer element within the wellbore. The invention described in the '959 patent provided a disk, to act as a gap spanning, structural member. The shoe segments described in the '959 patent include disk pockets on an inner surface thereof. Each disk pocket is centered over the gap that it is to bridge, so that a pocket for a single disk comprises two half pockets located on adjacent shoe segments. The disk in the '959 patent was designed to span the gap between adjacent segments that increases in size when the packer element is set in the wellbore.

[0021] Although the inventions described in the '959 and '279 patents work well for their intended purpose, there is a further need for an easily drillable downhole packer-type tool apparatus preferably being made at least partly, if not essentially entirely, of non-metallic, such as, but not limited to, composite components, and which include expandable packer elements to be partially retained by non-metallic segmented packer element shoes, or retaining rings that prohibit, or at least significantly reduce, unwanted extrusion of packer elements between gaps of such segmented shoes or segmented rings. While the invention described in the '279 patent works well in many cases, there is still a need for a retaining shoe that will prohibit, or at least limit unwanted extrusion of the packer element in high pressure, high temperature wells of up to, and exceeding 350° F and 15,000 psi.

[0022] Prior art apparatus according to the preamble of the appended independent claim 1 are disclosed in U.S. patent numbers 2,368,928 and 6,167,963.

[0023] The present invention provides apparatus as recited in the appended independent claim 1.

[0024] Further features of the present invention are provided as recited in the appended dependent claims.

[0025] Described below is a downhole apparatus for use in a wellbore having a casing therein, the apparatus comprising: a packer mandrel; a packer element assembly disposed about said packer mandrel, said packer element assembly having an upper end and a lower end, and being movable from an unset to a set position wherein said packer element assembly engages said casing in said set position; and at least one retaining shoe for axially retaining said packer element assembly, said retaining shoe comprising: a first shoe, said first shoe comprising a plurality of first shoe segments disposed about said

packer mandrel, said plurality of first shoe segments engaging one of said upper and lower ends of said sealing element assembly, adjacent ones of said first shoe segments having gaps therebetween; and a second shoe, said second shoe comprising a plurality of second shoe segments disposed about and engaging said first plurality of shoe segments, adjacent ones of said plurality of said second shoe segments having gaps therebetween, said retaining shoe having an initial position and a radially expanded second position, wherein said retaining shoe moves from said initial position to said second position when said packer element assembly moves from said unset to said set position, and wherein a width of said gaps between said first shoe segments and a width of said gaps between said second shoe segments increases when said retaining shoe moves from said initial to said second position, said first shoe segments covering said gaps between said second shoe segments, and said second shoe segments covering said gaps between said first shoe segments in said initial and said second position of said retaining shoe.

[0026] Described below is a retaining shoe for limiting the extrusion of a packer element assembly disposed about a packer mandrel, said packer element assembly being movable from an unset to a set position in a wellbore, wherein in said set position said packer element assembly seals against a casing in said wellbore, the retaining shoe comprising: a plurality of first shoe segments encircling said packer mandrel, said first shoe segments defining a sloped, arcuate inner surface for engaging an end of said packer element assembly, adjacent ones of said first shoe segments having gaps therebetween; and a plurality of second shoe segments disposed about said first shoe segments said second shoe segments defining a sloped, arcuate inner surface for engaging a sloped arcuate outer surface of said first shoe segments, said second shoe segments having gaps therebetween; wherein a width of said gaps between said first shoe segments and a width of said gaps between said second shoe segments increases when said packer element assembly moves from said unset to said set position, and wherein said first shoe segments cover said gaps between said second shoe segments and said second shoe segments cover said gaps in said first shoe segments.

[0027] Described below is a downhole apparatus for use in a wellbore having casing therein, the apparatus comprising: a mandrel having an axial centerline; a packer element assembly disposed about said mandrel, said packer element assembly having an upper end and a lower end and being movable from an unset position wherein said packer assembly and said casing define an annular gap therebetween, to a set position wherein said packer element assembly sealingly engages said casing; an upper retaining shoe for axially retaining said packer element, the upper retaining shoe comprising an inner retainer and outer retainer, the inner retainer comprising: a generally cylindrical shoe body disposed about said

mandrel; and a fin connected to and extending radially outwardly from said body, wherein said fin engages said upper end of said packer element assembly, the outer retainer being disposed about said inner retainer, said inner and outer retainers comprising expandable retainers movable from an initial position corresponding to said unset position of said packer element assembly wherein an annular gap exists between said upper retaining shoe and said casing, to an expanded position, corresponding to said set position of said packer element assembly wherein said upper retaining shoe engages said casing; and a lower retaining shoe, the lower retaining shoe comprising an inner retainer and an outer retainer, the inner retainer comprising: a generally cylindrical shoe body disposed about said mandrel; and a fin connected to and extending radially outwardly from said body, wherein said fin engages said upper end of said packer element assembly, the outer retainer being disposed about said inner retainer, said inner and outer retainers comprising expandable retainers movable from an initial position corresponding to the onset position of the packer element assembly wherein an annular gap exists between said lower retaining shoe and said casing, to an expanded position corresponding to the set position of the packer element assembly, wherein said lower retaining shoe engages said casing.

[0028] An embodiment of the present invention provides a downhole apparatus for preventing the extrusion of a packer element assembly installed about a mandrel. The embodiment includes a mandrel having a longitudinal central axis, a slip means disposed on the mandrel for grippingly engaging the wellbore when set into position, and a packer element assembly which includes at least one packer element to be axially retained about the mandrel. The invention also includes at least one packer element assembly retaining shoe disposed about the mandrel for axially retaining the packer element assembly and for preventing extrusion of the packer element assembly when the tool is set into position. The retaining shoe includes a first or inner shoe and a second or outer shoe. The inner shoe is comprised of a plurality of inner shoe segments. Adjacent ones of the inner shoe segments have gaps therebetween which may be zero when initially installed but which will expand from the initial installed position, wherein the gaps may be zero or slightly greater than zero, to a greater width when the tool is set into position. The inner shoe may comprise a generally cylindrical body which will engage the mandrel and a fin sloping radially outwardly therefrom which will engage the end of the packer element assembly. Each inner shoe segment thus comprises a body portion having a fin portion extending radially outwardly therefrom.

[0029] The second or outer shoe of the retaining shoe likewise is comprised of a plurality of outer shoe segments. Adjacent ones of the outer shoe segments will spread apart so that the width of a gap therebetween will expand as the retaining shoe moves from its initial position to an expanded position wherein the retaining shoe

engages the casing. The expanded position of the retaining shoe corresponds to the set position of the tool in the wellbore in which the packer element assembly engages the wellbore or casing disposed in the wellbore. In the expanded position of the retaining shoe, the retaining shoe engages the casing and prevents, or at least limits extrusion of the packer element assembly.

[0030] In order that the invention may be more fully understood, the following detailed description of a preferred embodiment is given in conjunction with the accompanying drawings which illustrate a preferred embodiment of the present invention. In the drawings:

FIG. 1 is a cross-sectional side view of a packer apparatus having upper and lower retaining shoes embodying the present invention;

FIG. 2 is a cross-sectional side view of a packer element assembly and the retaining shoes of the present invention;

FIG. 3 is a cross-sectional side view of a packer apparatus of the present invention in a set position;

FIG. 4 is a top view of an inner shoe of a retaining shoe of the present invention;

FIG. 5 is a perspective view of a single inner shoe segment;

FIG. 6 is a top view of the outer shoe of a retaining shoe of the present invention;

FIG. 7 is a perspective view of a single outer shoe segment of the present invention;

FIG. 8 is a perspective view of a retaining shoe of the present invention;

FIG. 9 is a cross-sectional side view of a prior art packer element and a retainer shoe; and

FIG. 10 shows a cross-section of another retaining shoe.

[0031] Referring now to FIGS. 1 and 2, downhole tool, or downhole apparatus 10 is shown in an unset position 11 in a well 15 having a wellbore 20 with a casing 22 cemented therein. Apparatus 10 is shown in set position 13 in FIG. 3. Casing 22 has an inner surface 24. An annulus 26 is defined by casing 22 and downhole tool 10. Downhole tool 10 has a mandrel 28, and may be referred to as a bridge plug due to the tool having a plug 30 being pinned within mandrel 28 by radially oriented pins 32. Plug 30 has a seal means 34 located between plug 30 and the internal diameter of mandrel 28 to prevent fluid flow therebetween. The overall tool structure, however, is adaptable to tools referred to as packers, which typically have at least one means for allowing fluid communication through the tool. Packers may therefore allow for the controlling of fluid passage through the tool by way of a one or more valve mechanisms which may be integral to the packer body or which may be externally attached to the packer body. Such valve mechanisms are not shown in the drawings of the present document. Packer tools may be deployed in wellbores having casings or other such annular structure or geometry in which

the tool may be set.

[0032] Mandrel 28 has an outer surface 36 an inner surface 38, and a longitudinal central axis, or axial centerline 40. An inner tube 42 is disposed in, and is pinned to mandrel 28 to help support plug 30.

[0033] Tool 10, which may also be referred to as packer apparatus 10, includes the usage of a spacer ring 44 which is preferably secured to mandrel 28 by pins 46. Spacer ring 44 provides an abutment which serves to axially retain slip segments 48 which are positioned circumferentially about mandrel 28. Slip retaining bands 50 serve to radially retain slips 48 in an initial circumferential position about mandrel 28 as well as slip wedge 52. Bands 50 are made of a steel wire, a plastic material, or a composite material having the requisite characteristics of having sufficient strength to hold the slips in place prior to actually setting the tool and to be easily drillable when the tool is to be removed from the wellbore. Preferably bands 50 are inexpensive and easily installed about slip segments 48. Slip wedge 52 is initially positioned in a slidable relationship to, and partially underneath slip segments 48 as shown in FIG. 1. Slip wedge 52 is shown pinned into place by pins 54. The preferred designs of slip segments 48 and co-acting slip wedges 52 are described in U.S. Patent No. 5,540,279.

[0034] Located below slip wedge 52 is a packer element assembly 56, which includes at least one packer element, and as shown in FIG. 1 includes three expandable elements 58 positioned about mandrel 28. Packer element assembly 56 has unset and set positions 57 and 59 corresponding to the unset and set positions 11 and 13 of tool 10. Assembly 56 has upper end 60 and lower end 62.

[0035] FIG. 9 shows a prior art arrangement wherein a single metallic shoe, such as shoe 64 is disposed about the upper and lower ends 60 and 62, respectively, of the packer element assembly 56. Referring to FIG. 1, the present invention has retaining rings 66 disposed at the upper and lower ends of packer element assembly 56. Retaining rings or retaining shoes 66 may be referred to as an upper retaining shoe or upper retainer 68 and a lower retaining shoe or lower retainer 70. A slip wedge 72 is disposed on mandrel 28 below lower retaining shoe 70 and is pinned with a pin 74. Located below lower slip wedge 72 are lower slip segments 76. Lower slip wedge 72 and lower slip segments 76 are like upper slip wedge 52 and upper slip segments 48. At the lowermost portion of tool 10 is an angled portion referred to as mule shoe 78, secured to mandrel 28 by pin 79. Lowermost portion 78 need not be a mule shoe but can be any type of section which will serve to terminate the structure of the tool or serves to be a connector for connecting the tool with other tools, a valve or tubing, etc. It will be appreciated by those in the art that pins 32, 46, 54, 74 and 79 if used at all are preselected to have shear strengths that allow for the tool to be set and deployed and to withstand the forces expected to be encountered in a wellbore during the operation of the tool.

[0036] Referring now to FIGS. 2 and 4-8, the retaining shoes of the present invention will be described. Upper and lower retaining shoes 68 and 70 are essentially identical. Therefore, the same designating numerals will be used to further identify features on each of retaining shoes 68 and 70, which are referred to collectively herein as retaining shoes 66. Retaining shoes 66 comprise an inner shoe or inner retainer 80 and an outer shoe or outer retainer 82. Inner and outer shoes 80 and 82 may also be referred to as first and second shoes or retainers 80 and 82. Outer shoe 82 is preferably made of a phenolic material available from General Plastics & Rubber Company, Inc., 5727 Ledbetter, Houston, Texas 77087-4095, which includes a direction-specific laminate material referred to as GP-B35F6E21K. Alternatively, structural phenolics available from commercial suppliers may be used. Inner shoes 80 are preferably made of a composite material available from General Plastics & Rubber Company, Inc., 5727 Ledbetter, Houston, Texas 77087-4095. A particular suitable material for a portion of the inner shoe 80 includes a direction specific composite material referred to as GP-L45425E7K available from General Plastics & Rubber Company, Inc. Alternatively, structural phenolics available from commercial suppliers may be used.

[0037] Referring now to FIGS. 2, 4, 5 and 8, inner shoe 80 has a body 88 and a fin or wing 90 extending radially outwardly therefrom. Inner shoe 80 has an inner surface 92 and an outer surface 94. As shown in FIG. 2, upper and lower ends 60 and 62 of packer element assembly 56 reside directly against upper and lower retainers 68 and 70 and preferably directly against wing 90 of inner shoe 80 at both the upper and lower ends 60 and 62 thereof. Inner shoe 80 is preferably comprised of a plurality of first or inner shoe segments 96 to form an inner shoe 80 that encircles mandrel 28. Inner surface 92 of inner shoe 80 is shaped to accommodate the ends 60 and 62 of the packer element assembly and thus is preferably sloped as well as arcuate to provide a generally truncated conical surface which transitions from having a greater radius proximate to an outer end, or outer face 98 of fin 90 to a smaller radius at an internal diameter 100 which is defined by body 88. Inner shoe 80 also has an inner end, or inner face 99. Inner surface 92 also defines a cylindrical surface on body 88 that engages mandrel 28 in an initial or running position of the tool. Each inner shoe segment 96 has ends 102 and 104 which are flat and convergent with respect to a center reference point which, if the shoe segments are installed about a mandrel will correspond to longitudinal central axis 40 of the mandrel as depicted in FIG. 1. End surfaces 102 and 104 need not be flat and can be of other topology.

[0038] Each segment 96 has a fin portion 93 and a body portion 95. Fin portions 93 and body portions 95 comprise body 88 and fin 90, respectively of inner shoe 80. FIG. 4 illustrates inner shoe 80 being made of a total eight inner shoe segments 96 to provide a 360° annulus encircling structure to provide a maximum amount of end

support for packer elements to be retained in the axial direction. A lesser amount, or greater amount, of shoe segments can be used depending on the nominal diameters of the mandrel, the packer elements, and the wellbore or casing in which the tool is to be deployed. Inner diameter 100 generally approaches the inner diameter of the packer element assembly. As is apparent from the drawings, outer surface 94 faces outwardly away from the tool. The slope of surface 92 on fin 90 is preferably approximately 45° as shown in FIG. 2. However, the exact slope will be determined by the exterior configuration of the packer element ends that are to be positioned and eventually placed to the contact with retaining shoe 66 and inner surface 92 on fin 90. Inner face 99 of inner shoe 80 is slightly sloped, approximately 5° if desired, but it is also best determined by the surface of the tool which it eventually abuts against when apparatus 10 is centered in the wellbore.

[0039] A gap 106 is defined by adjacent ends 104 and 102 of segments 96 before or after downhole tool 10 is set in the well. Gap 106 has a width 109 which can be essentially zero when the segments are initially installed about mandrel 28, and before the tool is moved from the unset to the set position. A small gap, for example a gap of 0,2 cm (06") may be provided for on initial installation. The width 109 of gap 106, as will be described in more detail herein below, will increase from that which exists on initial installation as the tool 10 is set.

[0040] Referring now to FIG. 6, outer shoe 82 has an inner surface 105 and an outer surface 107. Outer shoe 82 preferably has a plurality of individual shoe segments 108 to form outer shoe 82 which encircles inner shoe 80 and thus encircles mandrel 28. Shoe segments 108 have an inner surface 110, and an outer surface 116. Inner surface 105 of outer shoe 82 defines an inner diameter 112 and thus defines a generally cylindrical surface 114 adapted to engage outer surface of body 88 on inner shoe 80. Inner surface 105 likewise defines a truncated conical surface 115 to accommodate the outer surface of fin 90 and thus transitions from a greater radius proximate external, or outer surface 107 to the inner diameter 112. Ends 118 and 120 of segments 108 are flat and convergent with respect to a center reference point, which if the shoe segments are installed about a mandrel, corresponds to the longitudinal axial centerline such as longitudinal central axis 40 of mandrel 28. End surfaces 118 and 120 need not be flat and can be of other topology.

[0041] FIG. 6 illustrates outer shoe 82 being made of a total of eight shoe segments to provide a 360° annulus, or encircling structure to provide the maximum amount of end support. A lesser or greater amount of shoe segments can be used depending upon the nominal diameters of the mandrel, the packer elements in the wellbore or casing in which the tool is to be deployed. A base 121 of outer shoe 82 is slightly sloped, approximately 5°, if desired but is also best determined by the surface of the tool which the shoe will eventually abut against, as for example in this case, the slip wedges 52 and 72. An O-

ring 122 is received in a groove 124 in outer shoe 82. Retaining bands 126 are received in grooves 127 to initially hold the segments in place prior to actually setting the tool 10. Gap 128 is a space between adjacent ends 118 and 120 of segments 108 before or after the tool 10 is set. The gap will increase in width when the apparatus 10 is set. Retaining bands 126 are preferably made of a non-metallic material, such as composite materials available from General Plastics & Rubber Company, Inc., 5727 Ledbetter, Houston, Texas 77087-4095. However, shoe retaining bands 126 may be alternatively made of a metallic material such as ANSI 1018 steel or any other material having sufficient strength to support and retain the shoes in position prior to actually setting a tool employing such bands. Furthermore, retaining bands 126 may have either elastic or non-elastic qualities depending on how much radial, and to some extent axial, movement of the shoe segments can be tolerated prior to enduring the deployment of the associated tool into a wellbore. Referring now to FIGS. 1 and 2, apparatus 10 is shown in its unset position 11 and thus the packer element assembly 56 is in its unset position 57. FIG. 3 shows the set position 13 of the tool 10 and the corresponding set position 59 of the packer element assembly 56.

[0042] In unset position 57, retaining bands 126 serve to hold segments 108 in place, and thus also hold segments 96 in place. Prior to the tool being set, inner shoe 80 engages mandrel 28 about the upper and lower ends of the packer element assembly 56. Inner shoe 80 of the lower retaining shoe engages lower end 62 of packer element assembly 56 and inner shoe 80 of the upper retaining shoe 68 engages the upper end 60 of packer element assembly 56 in the unset position of tool and the packer element assembly. When the tool has reached the desired location in the wellbore, setting tools as commonly known in the art will move the tool 10 and thus the packer element assembly 56 to their set positions as shown in FIG. 3.

[0043] As shown in the perspective view of FIG. 8, inner shoe segments 96 are positioned so that gaps 106 which, as described before, may be zero when initially installed but may also be slightly greater than zero, will be located between the ends 118 and 120 of outer shoe segments 108. Likewise, gaps 128 between ends 118 and 120 of the outer shoe segments 108 will be positioned between the ends 102 and 104 of inner shoe segments 96. Gaps 106 are thus offset angularly from gaps 128. Gaps 128 are thus covered by segments 96, and gaps 106 are covered by segments 108. When the tool is moved to its set position retaining bands 126 will break and retaining shoes 66, namely both of retaining shoes 68 and 70, will move radially outwardly to engage inner surface 24 of casing 22. The radial movement will cause width 109 and width 129 of gaps 106 and 128, respectively, to increase. However, gaps 106 and 128 will still be angularly offset, and thus gaps 128 will remain covered by inner shoe segments 96 of inner shoe 80 while gaps 106 will remain covered by outer shoe segments

108 of outer shoe 82. O-ring 122 will exert a force radially inwardly on outer shoe 82, and will transfer the force to inner shoe 80 as the tool is being moved to its set position 13. The inward force applied by the O-ring 122, along with the friction between inner shoe 80 and outer shoe 82, provides for a generally equal separation between segments 96 and between segments 108, as retaining shoe 66 expands radially outwardly. In other words, the width 109 of each of gaps 106 and the width 129 of gaps 128, will be essentially uniform, or will vary only slightly as the retaining shoe 66 moves radially outwardly to its expanded position.

[0044] When the tool is moved to its set position, external, or outer surface 107 of shoe 82 will engage inner surface 24 of casing 22 as will outer end 98 of inner shoe 80. The extrusion of packer elements 58 is essentially eliminated, since any material extruded through gaps 106 will engage segments 108 of outer shoe 82 which will prevent further extrusion. Extrusion is likewise limited by upper and lower slip wedges 52 and 72, respectively. Retaining shoes 66 are thus expandable retaining shoes and will prevent or at least limit the extrusion of the packer elements. Inner and outer retainers 80 and 82 may also be referred to as expandable retainers. The arrangement is particularly useful in high pressure, high temperature wells, since there is no extrusion path available. It should be understood however, that the disclosed retaining shoes may be used in connection with packer-type tools of lesser or greater diameters, differential pressure ratings, and operating temperature ratings than those set forth herein.

[0045] Although the inner shoe in the embodiment described herein has a fin and a body, the body portion may be eliminated so that the inner face of the outer shoe will extend so that it engages the outer surface of the mandrel in the unset position. In other words, the inner shoe may comprise only the wing portion so that it will engage the upper and lower ends of the packer element assembly. Such an arrangement is shown in FIG. 10 in cross-section. This arrangement of FIG. 10 is not an embodiment of the invention. As shown in FIG. 10, a retaining shoe 150 may be disposed about mandrel 28 and may include a first or inner shoe 152 and a second or outer shoe 154. Inner shoe 152 is generally identical in all aspects to inner shoe 80, except that it does not include a body 88. Outer shoe 154 likewise is similar to outer shoe 82. However, as is apparent from the drawing, outer shoe 154 will engage mandrel 28 in the unset position of the tool. Inner shoe 152 and outer shoe 154, like inner and outer shoes 80 and 82, are comprised of a plurality of segments that will have gaps therebetween when retaining shoe 150 expands radially outwardly to engage a casing in the well. The segments are positioned so that the gaps between segments in inner shoe 152 are covered by the segments that make up outer shoe 154. Likewise, the gaps between segments in outer shoe 154 will be covered by the segments that comprise inner shoe 152. Thus, retaining shoe 150 will prevent, or at least limit, the extrusion of the pack-

er element assembly when it is in the set position.

Claims

1. A downhole apparatus for use in a wellbore having a casing therein, the apparatus comprising: a packer mandrel; a packer element assembly (56) disposed about said packer mandrel, said packer element assembly (56) having an upper end and a lower end, and being moveable from an unset to a set position wherein said packer element assembly engages said casing in said set position; and at least one retaining shoe (68,70) for axially retaining said packer element assembly (56), said retaining shoe (68,70) comprising: a first shoe (80), said first shoe (80) comprising a plurality of first shoe segments disposed about said packer mandrel, said plurality of first shoe segments engaging one of said upper and lower ends of said packer element assembly (56), adjacent ones of said first shoe segments having gaps therebetween; and a second shoe (82), said second shoe (82) comprising a plurality of second shoe segments disposed about and engaging said first plurality of shoe segments, adjacent ones of said plurality of said second shoe segments having gaps therebetween, said retaining shoe having an initial position and a radially expanded second position, wherein said retaining shoe moves from said initial position to said second position when said packer element assembly moves from said unset to said set position, and wherein a width of said gaps between said first shoe segments and a width of said gaps between said second shoe segments increases when said retaining shoe moves from said initial to said second position, said first shoe segments covering said gaps between said second shoe segments, and said second shoe segments covering said gaps between said first shoe segments in said initial and said second position of said retaining shoe; **characterised in that** each first shoe segment (96) engages the mandrel when said retaining shoe (68,70) is in said initial position and is located radially inwardly of each second shoe segment (108) so as to space each second shoe segment (108) from the mandrel.
2. Apparatus according to claim 1, wherein said first shoe segments engage said mandrel in said initial position and engage said casing in said second position, and wherein said second shoe segments and said casing in said casing define a space therebetween in the initial position of said retaining shoe, and wherein said second segments engage said casing in said second position of said retaining shoe (68,70).
3. Apparatus according to claim 1, wherein an inner

surface of said second shoe segments engages an outer surface of said first shoe segments, and wherein said second shoe segments engage said casing in said second position of said retaining shoe (68,70) and do not engage said mandrel in said initial or said second position of said retaining shoe (68,70).

4. Apparatus according to claim 1, wherein said first shoe segments comprise an arcuate inner surface adapted to engage one of said upper and lower ends of said packer element assembly (56).
5. Apparatus according to claim 1, wherein each said first shoe segment (96) comprises: a body portion (88), wherein said body portion (88) engages said mandrel when said retaining shoe is in said initial position; and a fin portion (90) extending radially outwardly from said body portion for engaging one of said upper or lower ends of said packer element assembly, wherein said body portions of said first shoe segments define a body of said first shoe, and wherein said fin portions (93) of said first shoe segments define a fin (90) of said first shoe.
6. Apparatus according to claim 5 comprising an upper retaining shoe and a lower retaining shoe, said upper retaining shoe being disposed at said upper end of said packer element assembly (56) and said lower retaining shoe being disposed at said lower end of said packer element assembly (56), wherein said fin (90) on said lower retaining shoe engages said lower end of said packer element assembly (56).
7. Apparatus according to claim 6, wherein said body generally defines a cylindrical shape when disposed about said mandrel, and wherein said fin (90) extends radially outwardly from said body.
8. Apparatus according to claim 5, wherein an inner surface of said second shoe defines a generally truncated cone shape for engaging said fin (90) of said first shoe.

Patentansprüche

1. Untertagevorrichtung zur Nutzung in einem Bohrloch mit einer Auskleidung, wobei die Vorrichtung umfasst: Eine Packerbuchse; eine Packerelementanordnung (56), welche um die Packerbuchse angeordnet ist, wobei die Packerelementanordnung (56) über ein oberes Ende und ein unteres Ende verfügt und beweglich ist von einer nicht fixierten zu einer fixierten Position, wobei die Packerelementanordnung in der fixierten Position in die Auskleidung eingreift; und mindestens einen Halteschuh (68, 70) zum axialen Halten der Packerelementanordnung (56), wobei der Halteschuh (68, 70) umfasst: Einen

ersten Schuh (80), wobei der erste Schuh (80) eine Vielzahl von Segmenten des ersten Schuhs umfasst, welche um die Packerbuchse angeordnet sind, und wobei die Vielzahl von Segmenten des ersten Schuhs in das obere oder das untere Ende der Packerelementanordnung (56) eingreifen, und sich Lücken zwischen benachbarten Segmenten des ersten Schuhs befinden; und einen zweiten Schuh (82), wobei der zweite Schuh (82) eine Vielzahl von Segmenten des zweiten Schuhs umfasst, welche um die erste Vielzahl von Schuhsegmente angeordnet sind und in diese eingreifen, und sich Lücken zwischen benachbarten Segmenten des zweiten Schuhs befinden, und der Halteschuh eine anfängliche Position und eine zweite radial vergrößerte Position besitzt, wobei sich der Halteschuh von der anfänglichen Position in die zweite Position bewegt, wenn die Packerelementanordnung sich von der nicht fixierten in die fixierte Position bewegt, und wobei sich eine Weite der Lücken zwischen den Segmenten des ersten Schuhs und eine Weite der Lücken zwischen den Segmenten des zweiten Schuhs vergrößert, wenn sich der Halteschuh von der anfänglichen in die zweiten Position bewegt, und in der anfänglichen und zweiten Position des Halteschuhs die Segmente des ersten Schuhs die Lücken zwischen den Segmenten des zweiten Schuhs bedecken und die Segmente des zweiten Schuhs die Lücken zwischen den Segmenten des ersten Schuhs bedecken, **dadurch gekennzeichnet, dass** jedes Segment (96) des ersten Schuhs in die Buchse eingreift, wenn der Halteschuh (68, 70) in der anfänglichen Position ist, und radial einwärts zu jedem Segment (108) des zweiten Schuhs so angeordnet ist, dass jedes Segment (108) des zweiten Schuhs mit einem Abstand zur Buchse angeordnet ist.

2. Vorrichtung nach Anspruch 1, wobei die Segmente des ersten Schuhs in der anfänglichen Position in die Buchse eingreifen und in der zweiten Position in die Auskleidung eingreifen, und wobei die Segmente des zweiten Schuhs und die Auskleidung in der anfänglichen Position des Halteschuhs in der Auskleidung einen Zwischenraum festlegen, und wobei die zweiten Segmente in der zweiten Position des Halteschuhs (68, 70) in die Auskleidung eingreifen.
3. Vorrichtung nach Anspruch 1, wobei eine innere Oberfläche der Segmente des zweiten Schuhs in eine äußere Oberfläche der Segmente des ersten Schuhs eingreift, und wobei die Segmente des zweiten Schuhs in der zweiten Position des Halteschuhs (68, 70) in die Auskleidung eingreifen und in der anfänglichen oder der zweiten Position des Halteschuhs (68, 70) nicht in die Buchse eingreifen.
4. Vorrichtung nach Anspruch 1, wobei die Segmente des ersten Schuhs eine bogenförmige innere Ober-

fläche enthalten, welche zum Eingriff in das obere oder das untere Ende der Packerelementanordnung (56) geeignet ausgebildet ist.

5. Vorrichtung nach Anspruch 1, wobei jedes Segment (96) des ersten Schuhs umfasst: Einen Körperteil (88), wobei der Körperteil (88) in die Buchse eingreift, wenn der Halteschuh in der anfänglichen Position ist, und einen Rippenteil (90), welcher sich radial auswärts von dem Körperteil erstreckt, um in das obere oder das untere Ende der Packerelementanordnung, einzugreifen, wobei die Körperteile der Segmente des ersten Schuhs einen Körper des ersten Schuhs festlegen, und wobei die Rippenabteile (93) der Segmente des ersten Schuhs eine Rippe (90) des ersten Schuhs festlegen. 5
10
6. Vorrichtung nach Anspruch 5, umfassend einen oberen Halteschuh und einen unteren Halteschuh, wobei der obere Halteschuh an dem oberen Ende der Packerelementanordnung (56) und der untere Halteschuh am unteren Ende der Packerelementanordnung (56) angeordnet ist, und wobei die Rippe (90) auf dem unteren Halteschuh in das untere Ende der Packerelementanordnung (56) eingreift. 15
20
25
7. Vorrichtung nach Anspruch 6, wobei der Körper im Wesentlichen eine zylindrische Form aufweist, wenn der Körper um die Buchse angeordnet ist, und wobei die Rippe (90) sich radial auswärts von dem Körper erstreckt. 30
8. Vorrichtung nach Anspruch 5, wobei eine innere Oberfläche des zweiten Schuhs eine im Wesentlichen kegelstumpfförmige Form zum Eingreifen der Rippe (90) des ersten Schuhs festlegt. 35

Revendications

1. Appareil de fond de puits, conçu pour être utilisé dans un puits de forage ayant en son sein un tubage, l'appareil comprenant : un mandrin d'étanchéité ; un ensemble d'éléments d'étanchéité (56) disposé autour dudit mandrin d'étanchéité, ledit ensemble d'éléments d'étanchéité (56) ayant une extrémité supérieure et une extrémité inférieure, et pouvant être déplacé d'une position non installée à une position installée dans laquelle ledit ensemble d'éléments d'étanchéité vient en prise avec ledit tubage dans ladite position installée ; et au moins un sabot de retenue (68, 70) pour retenir axialement ledit ensemble d'éléments d'étanchéité (56), ledit sabot de retenue (68, 70) comprenant : un premier sabot (80), ledit premier sabot (80) comprenant une pluralité de premiers segments de sabot disposés autour dudit mandrin d'étanchéité, ladite pluralité de premiers segments de sabot venant en prise avec une desdi- 40
45
50
55

tes extrémités supérieure et inférieure dudit ensemble d'éléments d'étanchéité (56), les segments adjacents desdits premiers segments de sabot étant espacés entre eux ; et un second sabot (82) ledit second sabot (82) comprenant une pluralité de seconds segments de sabot disposés autour de ladite pluralité de premiers segments de sabot et venant en prise avec ceux-ci, les segments adjacents de ladite pluralité de dits seconds segments de sabot étant espacés entre eux, ledit sabot de retenue ayant une position initiale et une seconde position radialement expansée, dans lequel ledit sabot de retenue se déplace de ladite position initiale à ladite seconde position quand ledit ensemble d'éléments d'étanchéité se déplace de ladite position non installée à ladite position installée, et dans lequel une largeur desdits espaces séparant lesdits premiers segments de sabot et une largeur desdits espaces séparant lesdits seconds segments de sabot augmente à mesure que ledit sabot de retenue se déplace de ladite position initiale à ladite seconde position, lesdits premiers segments de sabot couvrant lesdits espaces entre lesdits seconds segments de sabot, et lesdits seconds segments de sabot couvrant lesdits espaces entre lesdits premiers segments de sabot dans lesdites positions, initiale et seconde, dudit sabot de retenue ; **caractérisé en ce que** chaque premier segment de sabot (96) vient en prise avec le mandrin quand ledit sabot de retenue (68, 70) est dans ladite position initiale et qu'il est positionné radialement vers l'intérieur par rapport à chaque second segment de sabot (108) de sorte à espacer chaque segment de second sabot (108) du mandrin.

2. Appareil selon la revendication 1, dans lequel lesdits premiers segments de sabot viennent en prise avec ledit mandrin dans ladite position initiale et ils viennent en prise avec ledit tubage dans ladite seconde position, et dans lequel lesdits seconds segments de sabot et ledit tubage définissent dans ledit tubage un espacement mutuel dans ladite position initiale dudit sabot de retenue, et dans lequel lesdits seconds segments viennent en prise avec ledit tubage dans ladite seconde position dudit sabot de retenue (68, 70). 40
3. Appareil selon la revendication 1, dans lequel une surface interne desdits seconds segments de sabot vient en prise avec une surface externe desdits premiers segments de sabot, et dans lequel lesdits seconds segments de sabot viennent en prise avec ledit tubage dans ladite seconde position dudit sabot de retenue (68, 70) et ne viennent pas en prise avec ledit mandrin dans ladite position initiale ou ladite seconde position dudit sabot de retenue (68, 70). 45
4. Appareil selon la revendication 1, dans lequel lesdits premiers segments de sabot comprennent une sur- 50
55

face interne arquée adaptée pour venir en prise avec une desdites extrémités inférieure et supérieure dudit ensemble d'éléments d'étanchéité (56).

5. Appareil selon la revendication 1, dans lequel chaque dit premier segment de sabot (96) comprend : une partie formant corps (88), dans lequel ladite partie formant corps (88) vient en prise avec ledit mandrin quand ledit sabot de retenue est dans ladite position initiale ; et une partie formant ailette (90) s'étendant radialement vers l'extérieur à partir de ladite partie formant corps pour venir en prise avec une desdites extrémités supérieure ou inférieure dudit ensemble d'éléments d'étanchéité, dans lequel lesdites parties formant corps desdits premiers segments de sabot définissent un corps dudit premier sabot et dans lequel lesdites parties formant ailette (93) desdits premiers segments de sabot définissent une ailette (90) dudit premier sabot.
6. Appareil selon la revendication 5, comprenant un sabot de retenue supérieur et un sabot de retenue inférieur, ledit sabot de retenue supérieur étant disposé à ladite extrémité supérieure dudit ensemble d'éléments d'étanchéité (56) et ledit sabot de retenue inférieur étant disposé à ladite extrémité inférieure dudit ensemble d'éléments d'étanchéité (56), dans lequel ladite ailette (90) sur ledit sabot de retenue inférieur vient en prise avec ladite extrémité inférieure dudit ensemble d'éléments d'étanchéité (56).
7. Appareil selon la revendication 6, dans lequel ledit corps définit généralement une forme cylindrique quand il est disposé autour dudit mandrin, et dans lequel ladite ailette (90) s'étend radialement vers l'extérieur à partir dudit corps.
8. Appareil selon la revendication 5, dans lequel une surface interne dudit second sabot définit une forme généralement tronconique pour la mise en prise de ladite ailette (90) dudit premier sabot.

5

10

15

20

25

30

35

40

45

50

55

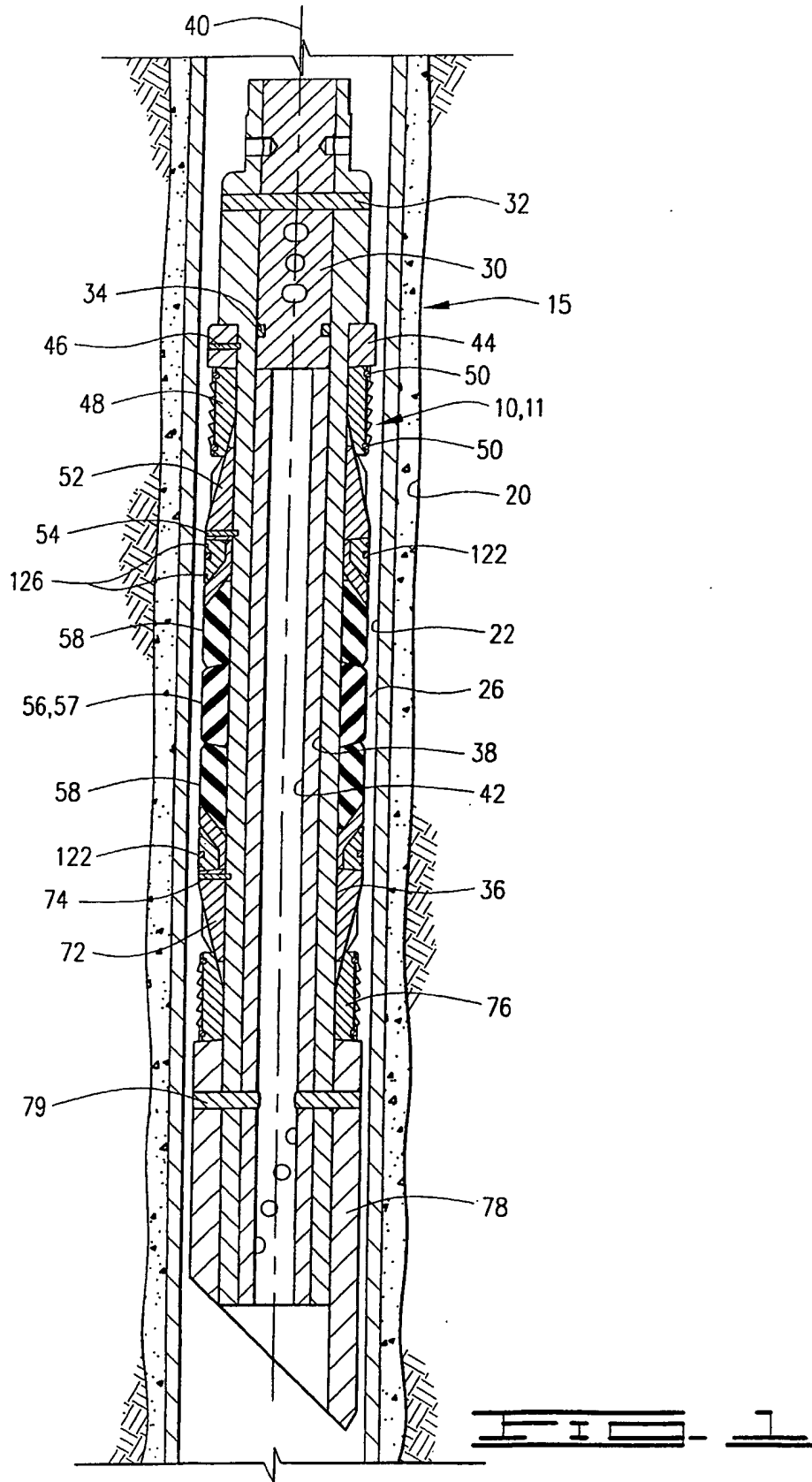

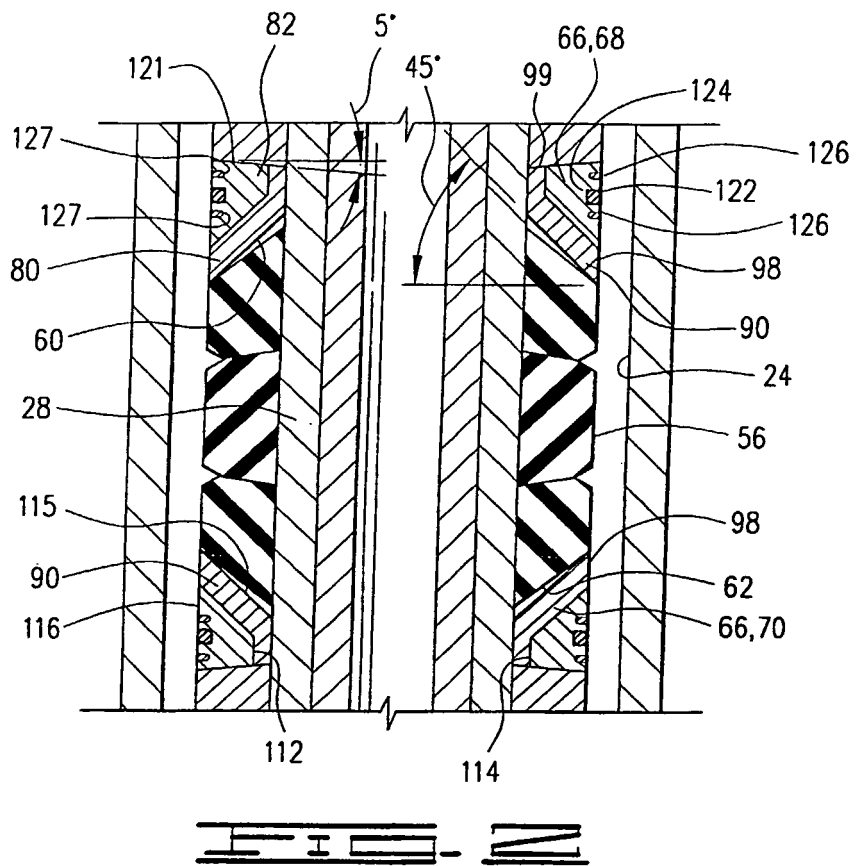

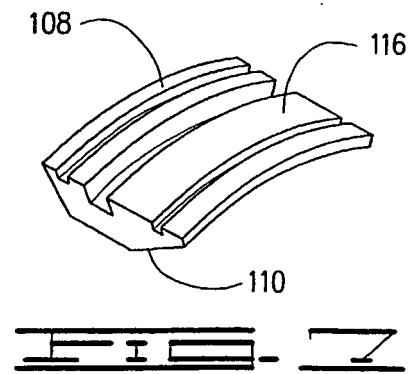
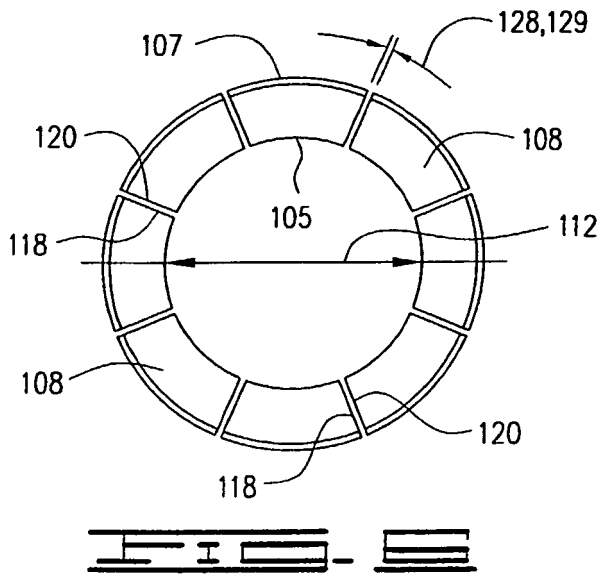
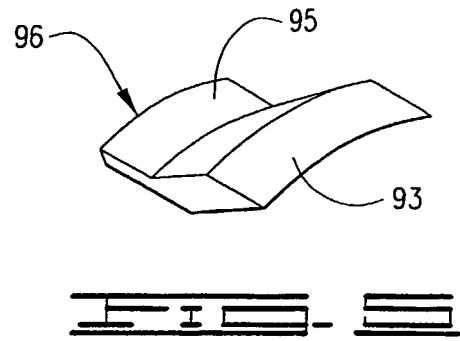
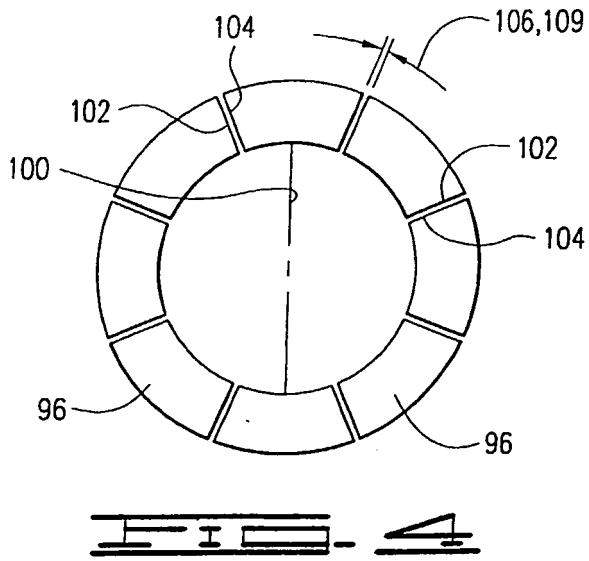

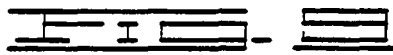
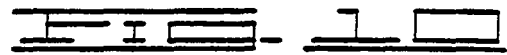
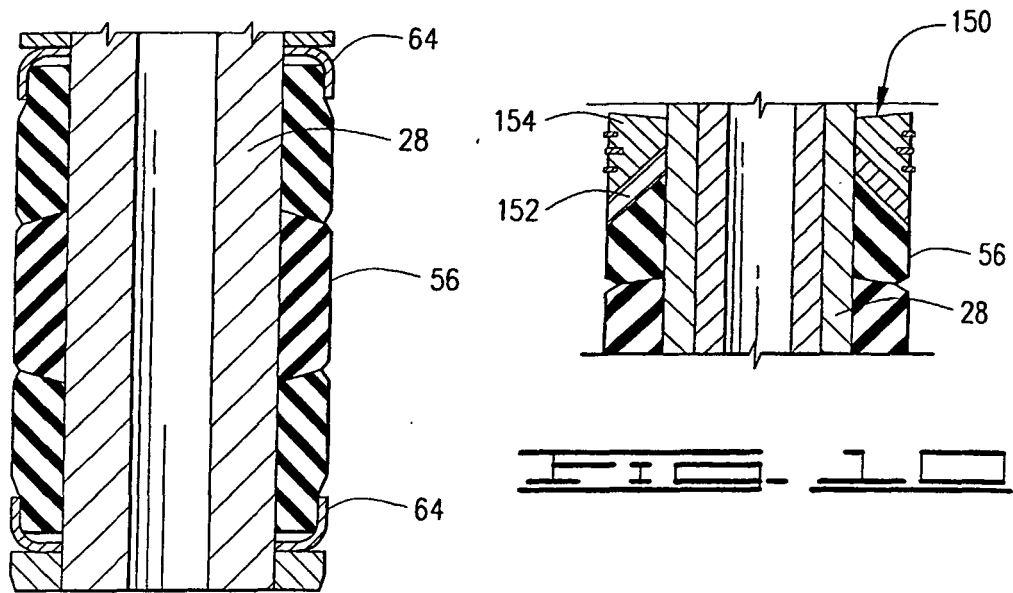
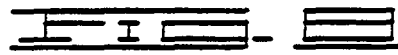
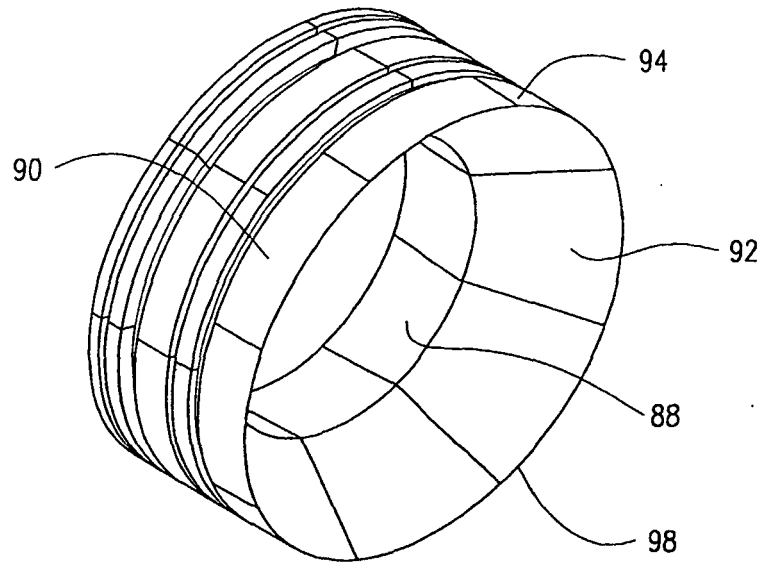

PRIOR ART

REFERENCES CITED IN THE DESCRIPTION

This list of references cited by the applicant is for the reader's convenience only. It does not form part of the European patent document. Even though great care has been taken in compiling the references, errors or omissions cannot be excluded and the EPO disclaims all liability in this regard.

Patent documents cited in the description

- US 4151875 A, Sullaway [0003]
- US 5271468 A, Streich [0010] [0015] [0017]
- US 5224540 A, Streich [0010] [0015]
- US 5390737 A, Jacobi [0010] [0015]
- US 44244895 A [0015]
- US 5540279 A [0015] [0033]
- US 5701959 A [0019]
- US 2368928 A [0022]
- US 6167963 A [0022]